

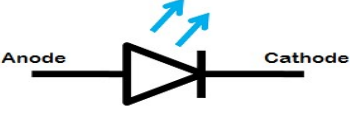

**Important suggestions to examiners:**

- 1) The answers should be examined by key words and not as word-to-word as given in the model answer scheme.
- 2) The model answer and the answer written by candidate may vary but the examiner may try to assess the understanding level of the candidate.
- 3) The language errors such as grammatical, spelling errors should not be given more importance. (Not applicable for subject English and communication skills)
- 4) While assessing figures, examiner may give credit for principle components indicated in a figure. The figures drawn by candidate and model answer may vary. The examiner may give credit for any equivalent figure drawn.
- 5) Credits may be given step wise for numerical problems. In some cases, the assumed constant values may vary and there may be some difference in the candidate's answers and model answer.
- 6) In case some questions credit may be given by judgment on part of examiner of relevant answer based on candidate understands.
- 7) For programming language papers, credit may be given to any other program based on equivalent concept.

<b>Q.1</b>	<b>Attempt any FIVE of the following :</b>	<b>10 Marks</b>
<b>a)</b>	<b>Draw the symbol of LED &amp; photodiode.</b>	
Ans	<b>Symbol of LED :</b>  <b>Symbol of photodiode :</b> 	<b>(2 Marks)</b>
<b>b)</b>	<b>Define rectifier and list its types.</b>	
Ans	<b>Definition:</b> A rectifier is a circuit that converts AC input voltage into DC output voltage. <b>Types :</b> 1) Half wave rectifier 2) Center tap full wave rectifier. 3) Bridge Rectifier	<b>(1 Mark)</b> <b>(1 Mark)</b>
<b>c)</b>	<b>List configurations of BJT.</b>	
Ans	<b>Configurations of BJT :</b> 1) Common Base (CB) configuration 2) Common Emitter (CE) configuration 3) Common Collector (CC) configuration	<b>(2 Marks)</b>
<b>d)</b>	<b>State the output voltage for IC 7824 and IC 7906.</b>	
Ans	<b>i) Output voltage for IC 7824 :</b> + 24 V <b>ii) Output voltage for IC 7906 :</b> - 6 V	<b>(1 Mark)</b> <b>(1 Mark)</b>
<b>e)</b>	<b>Suggest the suitable diode type for rectifier circuit.</b>	
Ans	Any general purpose diodes 1N4001 to 1N4007 series <b>OR</b> Silicon diode & Germanium diode	<b>(2 Marks)</b>

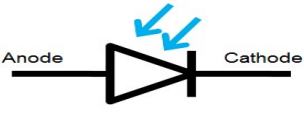

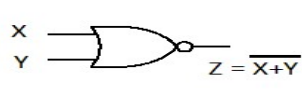
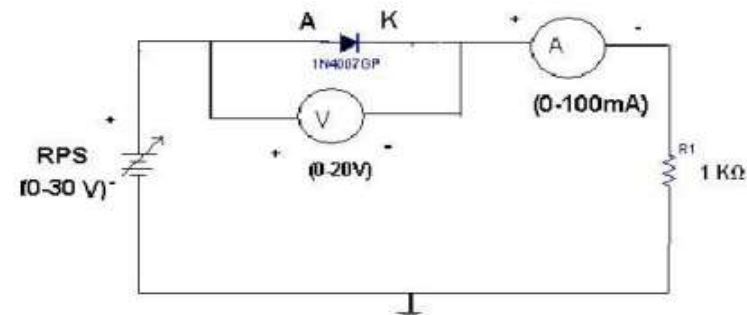
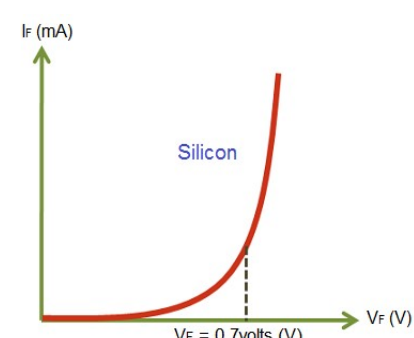
<b>f)</b>	<b>Define the term line regulation.</b>																			
Ans	<p><b>Line Regulation :</b> <span style="float: right;"><b>(2 Marks)</b></span></p> <p>Line regulation is the ability of a power supply to maintain a constant output voltage irrespective of any changes in input voltage.</p>																			
<b>g)</b>	<b>Draw the symbol, logic expression and truth table of NOR gate.</b>																			
Ans	<p><b>The Symbol, logic expression and truth table of NOR gate:</b> <span style="float: right;"><b>(2 Marks)</b></span></p> <p style="text-align: center;">NOR Gate</p> <div style="display: flex; align-items: center; justify-content: center;">  <table border="1" style="margin-left: 20px;"> <caption style="text-align: center;">TRUTH TABLE</caption> <thead> <tr> <th colspan="2">INPUTS</th> <th>OUTPUT</th> </tr> <tr> <th>X</th> <th>Y</th> <th>Z</th> </tr> </thead> <tbody> <tr> <td>0</td> <td>0</td> <td>1</td> </tr> <tr> <td>0</td> <td>1</td> <td>0</td> </tr> <tr> <td>1</td> <td>0</td> <td>0</td> </tr> <tr> <td>1</td> <td>1</td> <td>0</td> </tr> </tbody> </table> </div>	INPUTS		OUTPUT	X	Y	Z	0	0	1	0	1	0	1	0	0	1	1	0	
INPUTS		OUTPUT																		
X	Y	Z																		
0	0	1																		
0	1	0																		
1	0	0																		
1	1	0																		
<b>Q.2</b>	<b>Attempt any THREE of the following :</b>	<b>12 Marks</b>																		
a)	<b>Draw experimental circuit diagram and characteristics for forward biased P-N junction diode.</b>																			
Ans:	<p><b>Experimental circuit diagram:</b> <span style="float: right;"><b>(2 Marks)</b></span></p>  <p style="text-align: right;"><b>or equivalent figure</b></p> <p><b>Forward biased P-N junction diode :</b> <span style="float: right;"><b>(2 Marks)</b></span></p>  <p style="text-align: right;"><b>or equivalent figure</b></p>																			



**b) Explain Center-tapped full wave rectifier with the help of circuit diagram and draw input-output waveforms.**

Ans: **Diagram of Bridge rectifier:** (Diagram: 2 Mark & Explanation : 2 Mark)

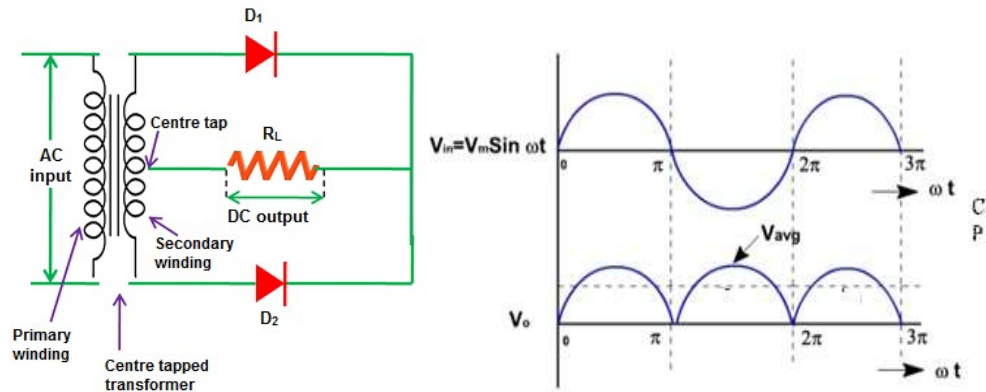

or equivalent diagram

**Operation :**

During positive half cycle of an AC supply, D1 will forward biased and current starts flowing through load. The output voltage is equal to +Vs.

During negative half cycle of an AC supply, D2 will forward biased and current starts flowing through load. The output voltage is equal to +Vs.

In this pulsating DC waveform will be obtained at the load.

**c) Describe the operation of NPN transistor with neat diagram.**

Ans: **Operation of NPN transistor-** (Diagram 2-Marks, Explanation 2-Marks)

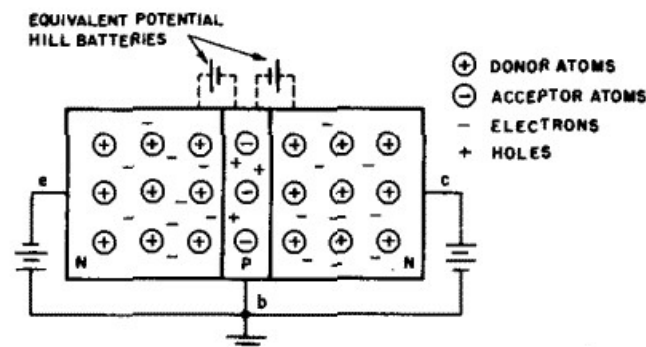

or equivalent figure

N-p-n transistor is made by sandwiching thin layer of p-type semiconductor between two layers of n-type semiconductor. It has three terminals - Emitter, Base and collector. The npn transistor has two supplies, one is connected through the emitter base and one through the collector base. The supply is connected such that emitter-base are forward biased and collector base are reverse biased. It means, Base has to be more positive than the emitter and in turn, the collector must be



more positive than the base. The current flow in this type of transistor is carried through movement of electrons. Emitter emits electrons which are pulled by the base as it is more positive. This ends up in the collector as it is more positive. In this way, current flows in the transistor.

d) Draw block diagram of IC 723. Write the functions of IC 723.

Ans:

**Block diagram of IC 723 :**

**(2 Marks)**

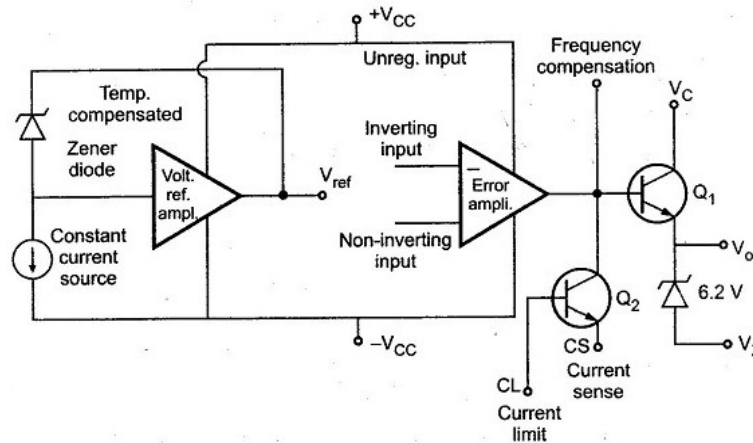

**or equivalent figure**

**Functions of IC 723 :**

**(2 Marks)**

1. Series, shunt, switching and floating regulators
2. Basic Low-voltage Regulator ( $V_o = 2$  to 37 volts)
3. Low Voltage High Current Regulator.

**OR**

**Block diagram explanation :**

Temperature compensated zener diode, constant current source and reference amplifier constitutes the reference element. In order to get a fixed voltage from zener diode, the constant current source forces the zener to operate at a fixed point.

Output voltage is compared with this temperature compensated reference potential of the order of 7 volts. Error amplifier is high gain differential amplifier. Its inverting input is connected to the either whole regulated output voltage or part of that from outside. For later case a potential divider of two scaling resistors is used. Scaling resistors help in getting multiplied reference voltage or scaled up reference voltage.

Error amplifier controls the series pass transistor  $Q_1$ , which acts as variable resistor. The series pass transistor is a small power transistor having about 800 mW dissipation. The unregulated power supply source ( $< 36V$  d.c.) is connected to collector of series pass transistor.

Transistor  $Q_2$  acts as current limiter in case of short circuit condition. It senses drop across  $l_c$  placed in series with regulated output voltage externally.



**WINTER- 2018 Examinations**

Subject Code: 22213

**Model Answer**

Page 5 of 13

The frequency compensation terminal controls the frequency response of the error amplifier. The required roll-off is obtained by connecting a small capacitor of 100 pF between frequency compensation and inverting input terminals.

**Q.3 Attempt any THREE of the following : 12 Marks**

**a) Draw the block diagram of regulated DC power supply and explain the function of each block.**

Ans: **Diagram : ( 2 Mark)**

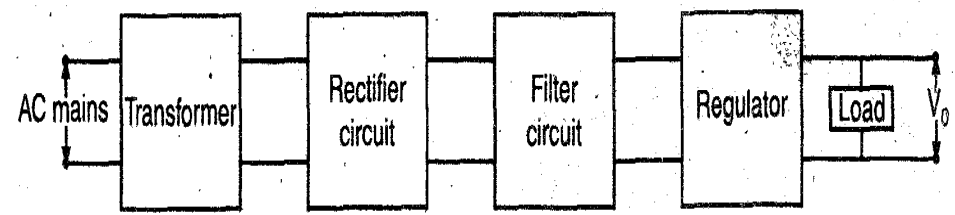

**or equivalent figure**

**Functions of each block: ( 2 Mark)**

- 1) Transformer:**  
It Converts an AC input source to AC required output without changing frequency. The transformer is step up or step down transformer.
- 2) Rectifier:**  
It is a circuit which is used to convert AC into pulsating DC. A rectifying diode is used.
- 3) Filter:**  
It is a circuit used to convert pulsating DC into pure DC. A inductor and capacitors are used as filter
- 4) Voltage regulator:**  
An unregulated DC voltage is converted into regulated DC voltage. IC 78XX & 79XX series are used as regulator.

**b) Differentiate between positive and negative feedback on the basis of . (i) overall phase shift (ii) voltage gain (iii) stability (iv) applications**

Ans: **( 1 Mark each Point)**

S.No.	Parameter	Positive feedback	Negative feedback
i)	overall phase shift	0° or 360° (In phase)	180° out of phase
ii)	voltage gain	Increases	Decreases
iii)	stability	Poor	Better
iv)	applications	Oscillator	Amplifier



<b>c)</b>	<b>Describe transistor as a switch with neat sketch.</b>	
<b>Ans:</b>	<p><b>Working :</b> <span style="float: right;"><b>( Diagram 2 Marks Explanation 2 Marks)</b></span></p> <p>From the circuit we can see that the control input <math>V_{in}</math> is given to base through a current limiting resistor <math>R_b</math> and <math>R_c</math> is the collector resistor which limits the current through the transistor</p> <div style="display: flex; justify-content: space-around; align-items: flex-start;"> <div style="text-align: center;"> <p>Transistor as a Switch – ON</p> </div> <div style="text-align: center;"> <p>Transistor as a Switch – OFF</p> </div> </div> <p style="text-align: center;"><b>or equivalent figure</b></p> <p>When a sufficient voltage <math>V</math> is given to input, transistor becomes ON &amp; it goes into saturation. During this condition the Collector Emitter voltage <math>V_{ce}</math> will be approximately equal to zero, i.e. the transistor acts as a short circuit &amp; <math>V_o = 0</math>.</p> <p>When input voltage <math>V=0</math>, transistor becomes OFF &amp; it goes into cutoff. The transistor acts as an open circuit. During this condition the Collector Emitter voltage <math>V_{ce}=V_{cc}</math>. Therefore <math>V_o = V_{cc}</math>.</p>	
<b>d)</b>	<b>An AC supply of 230 V is applied to half wave rectifier circuit. A transformer turns ratio is 20 : 1. Find i) Output DC voltage (ii) Peak Inverse Voltage (PIV)</b>	
<b>Ans:</b>	<p>Given Data : <math>V_{\text{primary}} = 230\text{Vrms}</math>. Turns ratio = 20:1</p> <p style="text-align: right;"><math>V_{\text{secondary}} = V_{\text{primary}} / 20 = 230 / 20 = 11.5\text{ Vrms}</math> <span style="float: right;"><b>( 1 Mark)</b></span></p> <p style="text-align: right;"><math>V_m = \sqrt{2} \times V_{\text{rms}} = \sqrt{2} \times 11.5 = 16.26\text{ V}</math> <span style="float: right;"><b>( 1 Mark)</b></span></p> <p>i) <b>Output DC voltage</b> = <math>V_m / \pi = 16.26 / 3.14 = 5.17\text{ V}</math> <span style="float: right;"><b>( 1 Mark)</b></span></p> <p>ii) <b>Peak Inverse Voltage (PIV)</b> = <math>V_m = 16.26\text{ V}</math> <span style="float: right;"><b>( 1 Mark)</b></span></p>	

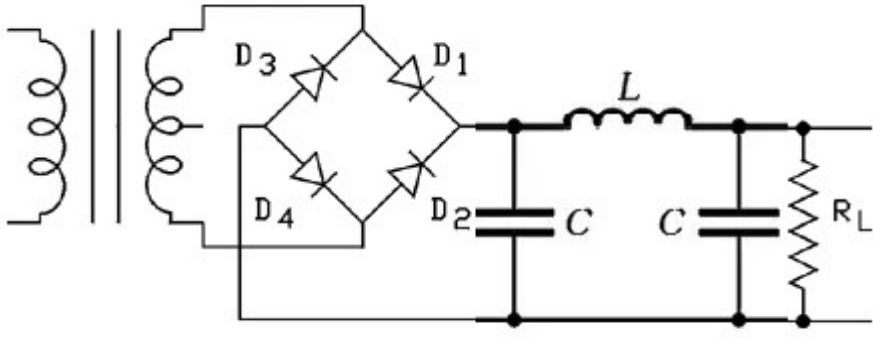
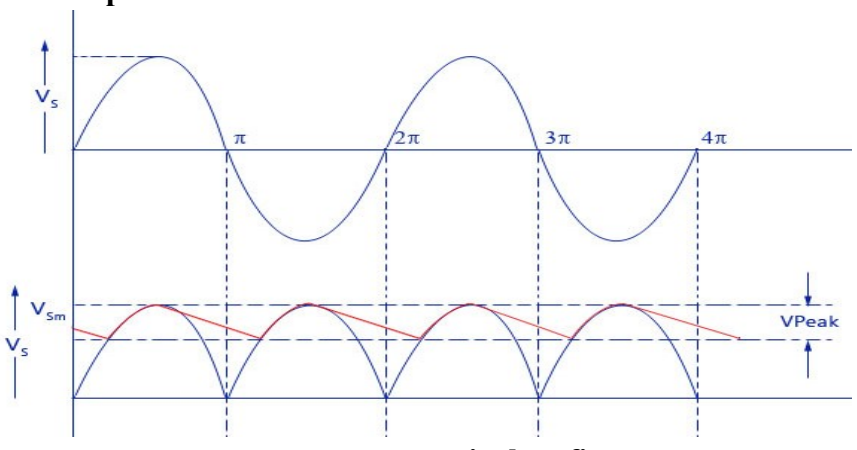

Q.4	Attempt any THREE of the following :	12 Marks
a)	List the applications of RC oscillator and crystal oscillator. (two each)	
Ans:	<p><b>Applications of RC oscillator :</b> <span style="float: right;">(Any two 2 Marks)</span></p> <ol style="list-style-type: none"><li>1) In AF signal generators</li><li>2) In radio transmitter &amp; Receivers</li><li>3) Sine wave generator.</li></ol> <p><b>Applications of Crystal oscillator</b> <span style="float: right;">(Any two 2 Marks)</span></p> <ol style="list-style-type: none"><li>1) Electronic navigation systems</li><li>2) Frequency Synthesizers</li><li>3) Timing circuits (Clock) with high stability.</li><li>4) RADAR systems.</li></ol>	
b)	Draw the circuit diagram of bridge rectifier with $\pi$ filter. Draw its input and output waveform.	
Ans:	<p><b>Circuit diagram of bridge rectifier with <math>\pi</math> filter :</b> <span style="float: right;">( 2 Marks)</span></p>  <p style="text-align: center;">or equivalent figure</p> <p><b>Input and output waveform:</b> <span style="float: right;">( 2 Marks)</span></p>  <p style="text-align: center;">or equivalent figure</p>	



c)	<b>In a common base connection, current amplification factor (<math>\alpha</math>) is 0.9. If the emitter current is 1 mA, determine the value of base current.</b>
Ans:	<p>Given data : <math>\alpha = 0.9</math> <span style="float: right;">( Equation 2 Marks &amp; Answer 2 Marks)</span></p> <p><math>I_E = 1\text{mA}</math></p> <p>As <math>\alpha = I_C / I_E</math></p> <p>Therefore <math>I_C = 0.9\text{mA}</math></p> <p><math>I_E = I_C + I_B</math> .....(Assume <math>I_{CBO} = 0</math>)</p> <p><math>I_B = 0.1\text{mA}</math></p> <p><b>OR</b></p> <p><math>I_B = (1 - \alpha) I_E</math></p> <p><math>I_B = 0.1\text{mA}</math></p>
d)	<b>Describe the working principle of photodiode with proper diagram.</b>
Ans:	<p><b>Diagram of photo diode :</b> <span style="float: right;">(2 Mark)</span></p> <div data-bbox="422 1025 1109 1473" data-label="Diagram"></div> <p style="text-align: right;">or equivalent figure</p> <p><b>Working principle of photo diode :</b> <span style="float: right;">(2 Marks)</span></p> <p>When photons of energy greater than 1.1 eV hit the diode, electron-hole pairs are created. The intensity of photon absorption depends on the energy of photons – the lower the energy of photons, the deeper the absorption is. This process is known as the inner photoelectric effect.</p> <p>If the absorption occurs in the depletion region of the p-n junction, these electron hole pairs are swept from the junction - due to the built-in electric field of the depletion region. As a result, the holes move toward the anode and the electrons move toward the cathode, thereby producing photocurrent.</p>



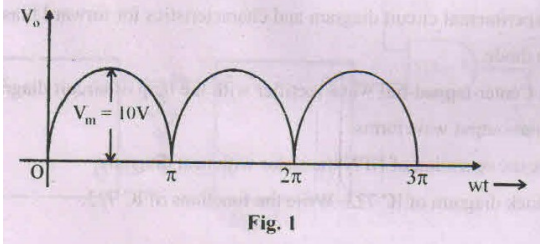

e)	<p>In a full wave rectifier <math>V = 10\text{ V}</math>, <math>R_L = 10\text{ k}\Omega</math>. Find out <math>V_{DC}</math>, <math>I_{DC}</math> and Ripple factor. [Refer Fig. 1]</p>  <p>Fig. 1</p>
Ans:	<p>Given Data : <math>V_m = 10\text{ V}</math> , <math>R_L = 10\text{ K}</math></p> <p><math>V_{DC} = 2V_m/\pi = 6.367\text{ V}</math> <span style="float: right;">( 1 Mark)</span></p> <p><math>I_{DC} = V_{DC}/R_L = 0.637\text{ mA}</math> <span style="float: right;">( 1 Mark)</span></p> <p><math>I_m = V_m/ R_L = 1\text{ mA}</math> <span style="float: right;">( 1 Mark)</span></p> <p>Ripple Factor = <math>\sqrt{\left[\frac{I_{RMS}}{I_{DC}}\right]^2 - 1} = 0.48</math> <span style="float: right;">( 1 Mark)</span></p>
Q.5	<p>Attempt any TWO of the following : <span style="float: right;">12 Marks</span></p>
(a)	<p>Identify type of BJT configuration having following features :</p> <p>(i) BJT configuration having the least current gain.</p> <p>(ii) BJT configuration called as voltage follower.</p> <p>(iii) BJT configuration having current gain less than one.</p> <p>(iv) BJT configuration suitable for impedance matching.</p> <p>(v) BJT configuration suitable for voltage amplification.</p> <p>(vi) BJT configuration having the least output impedance.</p>
Ans:	<p style="text-align: right;">(Each 1 Mark)</p> <p>(i) BJT configuration having the least current gain : <b>Common Base Configuration</b></p> <p>(ii) BJT configuration called as voltage follower: <b>Common Collector Configuration</b></p> <p>(iii) BJT configuration having current gain less than one : <b>Common Base Configuration</b></p> <p>(iv) BJT configuration suitable for impedance matching: <b>Common Collector Configuration</b></p> <p>(v) BJT configuration suitable for voltage amplification: <b>Common Emitter Configuration</b></p> <p>(vi) BJT configuration having the least output impedance: <b>Common Collector Configuration</b></p>



**b)**

**Find out the input voltage of the zener regulator shown in Fig. 2. Assume  $R_s = 200 \Omega$  and  $I_{Z(max)} = 25 \text{ mA}$ .**

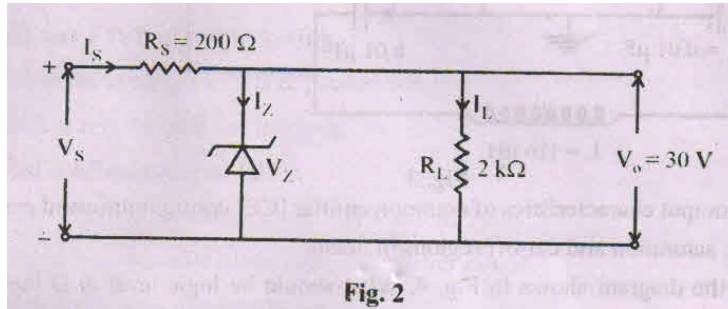

**Ans:** Given  $R_s = 200 \text{ ohm}$ ,  $R_L = 2\text{Kohm}$  ,  $I_{z(max)} = 25\text{mA}$

$$V_o = 30\text{V}$$

$$\text{So } V_z = V_o = 30\text{V.}$$

**(1 Mark)**

**The input voltage range**

A )  $V_{s,max} = I_{Rmax} \times R + V_z \dots\dots\dots(1)$

**(1 Mark)**

$$I_{Rmax} = I_{z,max} + I_L = I_{zmax} + V_z/R_L = 40 \text{ mA.}$$

**(1 Mark)**

Therefore from equation (1)

$$V_{s,max} = 38 \text{ V}$$

**(1 Mark)**

B) Assuming  $I_z \text{ min} = 20 \% \text{ of } I_z \text{ max} = 5 \text{ mA}$  ... Practically to maintain zener diode in breakdown condition.

$$\text{So , } V_{s \text{ min}} = I_s R_s + V_z \dots\dots\dots I_s = I_z + I_L = 20 \text{ mA}$$

$$= 34 \text{ V.}$$

**So, Input voltage ranging from 34V to 38V.**

**(2 Marks)**

**Note : Full marks may be given for calculating input  $V_{smax} = 38\text{V}$**

**c)**

**Convert the following numbers :**

i)  $(456)_{10} = ( )_2$

ii)  $(5A)_{16} = ( )_{10}$

iii)  $(43)_{10} = ( )_2$

vi)  $(101011)_2 = ( )_{16}$

v)  $(204)_{10} = ( )_8$

vi)  $(259)_{10} = ( )_{16}$

**Ans:** **Convert the following numbers : ( 1 Mark each convert Number)**

i)  $(456)_{10} = (111001000)_2$

ii)  $(5A)_{16} = (90)_{10}$

iii)  $(43)_{10} = (101011)_2$

iv)  $(101011)_2 = (28)_{16}$  ,

v)  $(204)_{10} = (314)_8$  ,

vi)  $(259)_{10} = (103)_{16}$



<b>Q.6</b>	<b>Attempt any TWO of the following :</b>	<b>12 Marks</b>
<b>a)</b>	<p><b>Identify the circuit shown in Fig. 3. Find out frequency of oscillator of the circuit.</b></p> <div style="text-align: center;"> <p style="text-align: center;">Fig. 3</p> </div>	
Ans:	<p><b>Circuit Diagram : Colpitts Oscillator</b></p> $\text{Frequency} = \frac{1}{2\pi\sqrt{LC_{eq}}} \quad \text{where} \quad C_{eq} = \frac{C_1 C_2}{C_1 + C_2}$ <p style="text-align: center;">So <math>C_{eq} = 5nF</math></p> <p style="text-align: center;">&amp; <math>f = 208.95 \text{ KHz.}</math></p>	<p><b>(2 Marks)</b></p> <p><b>(2 Marks)</b></p> <p><b>(2 Marks)</b></p>
<b>b)</b>	<b>Draw output characteristics of common emitter [CE] configuration and explain active, saturation and cut-off regions in detail.</b>	
Ans:	<p><b>Characteristics of common emitter [CE] configuration</b></p> <div style="text-align: center;"> <p style="text-align: center;"><b>Output Characteristic Curve</b></p> <p style="text-align: right; font-size: small;">Circuit Globe</p> </div>	<b>(3 Marks)</b>

or equivalent figure



**Explanation :**

**(3 Marks)**

**(1) Active Region:**

In this region collector junction is reverse biased and emitter junction is forward biased. It is the area to the right of  $V_{CE} = 0.5\text{ V}$  and above  $I_B = 0$ . In this region transistor current responds most sensitively to  $I_B$ . If transistor is to be used as an amplifier, it must operate in this region.

**(2) Cut Off:**

In this region collector junction is reverse biased and emitter junction is reverse biased. Cut off in a transistor is given by  $I_B = 0, I_C = I_{CO}$ .

**(3) Saturation Region:**

In this region both junctions are forward biased. Since the voltage  $V_{BE}$  and  $V_{BC}$  across a forward is approximately  $0.7\text{ V}$  therefore,  $V_{CE} = V_{CB} + V_{BE} = -V_{BC} + V_{BE}$  is also few tenths of volts. In this region the transistor collector current is approximately given by  $V_{CC} / R_C$  and independent of base current.

**Refer the diagram shown in Fig. 4. What should be logic level at D input to make : (i) LED ON (ii) LED OFF (iii) Justify your answer by giving step-by-step output of each stage. o+ 5V**

c)

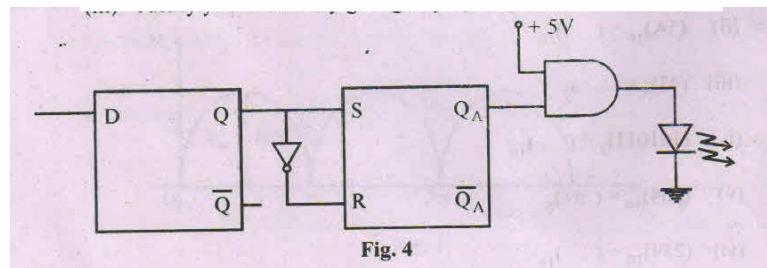

Ans:

**D Flip Flop Truth Table:**

**SR Flip Flop Truth Table:**

clk	D	Q	$\bar{Q}$
0	0	Q	$\bar{Q}$
0	1	Q	$\bar{Q}$
1	0	0	1
1	1	1	0

S	R	Q	State
0	0	Previous State	No change
0	1	0	Reset
1	0	1	Set
1	1	?	Forbidden

Looking at the truth table and given circuit diagram to get logic level at D input for following output :



MAHARASHTRA STATE BOARD OF TECHNICAL EDUCATION  
(Autonomous)  
(ISO/IEC-27001-2005 Certified)

WINTER- 2018 Examinations

Subject Code: 22213

Model Answer

Page 13 of 13

i) **LED ON:** This indicates output of SR FF  $Q_A = 1$ . To get  $Q_A = 1$ ,  $S = 1$ .

So,  $Q=1$ . To get  $Q=1$ ,  $D=1$ .

**Therefore  $D = 1$  for LED ON condition (3 Marks)**

ii) **LED OFF:** This indicates output of SR FF  $Q_A = 0$ . To get  $Q_A = 0$ ,  $S = 0$ .

So,  $Q=0$ . To get  $Q=0$ ,  $D=0$ .

**Therefore  $D = 0$  for LED OFF condition (3 Marks)**

-----END-----