



Model Answers
Winter – 2018 Examinations

Subject & Code: Fundamentals of Electrical Engineering (22212)

Important Instructions to examiners:

- 1) The answers should be examined by key words and not as word-to-word as given in the model answer scheme.
- 2) The model answer and the answer written by candidate may vary but the examiner may try to assess the understanding level of the candidate.
- 3) The language errors such as grammatical, spelling errors should not be given more importance (Not applicable for subject English and Communication Skills).
- 4) While assessing figures, examiner may give credit for principal components indicated in the figure. The figures drawn by candidate and model answer may vary. The examiner may give credit for any equivalent figure drawn.
- 5) Credits may be given step wise for numerical problems. In some cases, the assumed constant values may vary and there may be some difference in the candidate's answers and model answer.
- 6) In case of some questions credit may be given by judgement on part of examiner of relevant answer based on candidate's understanding.
- 7) For programming language papers, credit may be given to any other program based on equivalent concept.



Model Answers
Winter – 2018 Examinations

Subject & Code: Fundamentals of Electrical Engineering (22212)

- 1 Attempt any FIVE of the following: 10
- 1 a) State any two types of resistors. Give one application of each.
- Ans:**
Types of resistors with their applications:
- i) **Carbon composition resistor:** Potential divider, welding control circuits, power supplies, H. V. and high impulse circuits as switching spark circuits, radio/TV receiver circuit, biasing circuits of transistor, amplifier circuits, zener voltage regulator. 1 mark for each of any two types with one application = 2 Marks
- ii) **Metal film resistor:** Transmitter circuits, Oscillator, telecommunication circuits, testing circuits, measurement circuits, audio amplifier circuits, Modulator and De-modulator circuits.
- iii) **Wire wound resistor:** Power amplifiers, Zener voltage regulators, radio / TV receiver circuit, High power resistance in DC power supplies, measurement circuits.
- iv) **H V Ink Film type resistor:** C R O circuits, Radar, medical electronics.
- v) **Carbon film resistors:** used for electronic circuits
- vi) **Cermet resistors:** used in printers, automotive, computers, cell phones & battery chargers.
- 1 b) Define unilateral and bilateral circuit.
- Ans:**
Unilateral Circuit: If the characteristic (response or behavior) of circuit depends on the direction of flow of current through its elements, then the network is called as a unilateral network. 1 mark
- Bilateral Circuit:** If the characteristic (response or behavior) of circuit is independent of the direction of current through its elements, then the network is called as a bilateral network. 1 mark
- 1 c) Define breakdown voltage and dielectric strength of a capacitor.
- Ans:**
Breakdown Voltage: The voltage at which the dielectric material breaks down (Starts conducting or is no longer remains as an insulator) for a specified thickness, is called its breakdown voltage. 1 mark
- Di-electric Strength:** The voltage which a dielectric material can withstand without breaking down (without losing its dielectric property) is called its dielectric strength. 1 mark
- 1 d) What is magnetic hysteresis?
- Ans:**
Magnetic Hysteresis: When the magnetic material is subjected to a cycle of magnetization and demagnetization for both the directions of the current, then it is found that flux density B in magnetic material lags behind the applied magnetizing force H. This phenomenon is known as magnetic hysteresis. 2 marks
- 1 e) Define reluctance and permeance with respect to magnetic circuit.
- Ans:**
Reluctance: The opposition offered by magnetic circuit to establish magnetic flux in it, is called as “Reluctance”. 1 mark



Model Answers
Winter – 2018 Examinations

Subject & Code: Fundamentals of Electrical Engineering (22212)

Permeance: It is the reciprocal of reluctance and implies the magnetic core's readiness with which magnetic flux is developed. 1 mark

1 f) State Faraday's laws of electromagnetic induction.

Ans:

Faraday's laws of electromagnetic induction:

First law: When a conductor cuts the magnetic flux or a changing magnetic field links with a conductor, an emf is induced in the conductor. 1 mark

Second law: The magnitude of emf induced in the conductor is directly proportional to the rate of change of flux linking with conductor or rate of flux cutting by the conductor. 1 mark

1 g) State Fleming's right hand rule.

Ans:

Fleming's Right Hand Rule:

Stretch out the first three fingers of your right hand such that they are mutually perpendicular to each other, align first finger in direction of magnetic field, thumb in direction of motion of conductor with respect to magnetic field, then the middle finger will give the direction of induced emf in conductor.

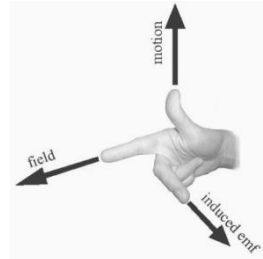

2 marks for statement (figure is optional)

2 Attempt any **THREE** of the following:

12

2 a) Name the effect of electric current observed in electroplating. Explain the same.

Ans:

Effect of Electric Current Observed in Electroplating: Chemical effect of electric current is observed in electroplating. 1 mark

Chemical Effect of Electric Current: Whenever a DC current is passed through a chemical solution, the solution is decomposed into its constituent substances. It is utilized in the electrolytic processes such as electro-plating, electro-refining, in production of different chemicals etc. 1 mark

Some liquids are good conductors of electricity and some are poor conductors. Most liquids that conduct electricity are solutions of acids, bases and salts. The passage of an electric current through a conducting liquid causes chemical reactions. The resulting effect is called chemical effect of current. The process of depositing a layer of any desired metal on another material, by means of electricity, is called electroplating. 2 marks

2 b) Why the emf of a cell is always greater than its terminal voltage? Explain the same

Ans:

Why the EMF of a Cell is Always Greater Than its Terminal Voltage:

Every practical source offers some opposition to the current due to its internal parts or components. Such a resistance of internal parts of source is called internal resistance of source. When source delivers current to load, the current flowing through the internal resistance causes voltage drop across it. This voltage drop is called internal voltage drop. Due to this internal voltage drop, the emf of a cell is always greater than its terminal voltage of practical voltage source. 2 marks

Model Answers

Winter – 2018 Examinations

Subject & Code: Fundamentals of Electrical Engineering (22212)

$$V_T = V_s - I \times R_{int}$$

Terminal voltage (V_T) is obtained at cell terminals. When emf source (V_s) is connected to load, current (I) flows through the circuit. Due to voltage drop across internal resistance ($I \times R_{int}$), terminal voltage obtained is less than emf induced. So, emf of a cell is always greater than terminal voltage.

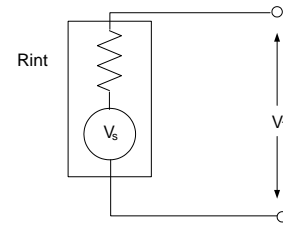

1 mark for circuit diagram

1 mark for explanation

2 c) Describe the construction of any one type of capacitor.

Ans:

Types of capacitors and their constructions:

i) Air capacitors:

Air capacitors are capacitors which use air as their dielectric. The simplest air capacitors are made of two conductive plates separated by an air gap. Air capacitors can be made in a variable or fixed capacitance form. Fixed capacitance air capacitors are rarely used since there are many other types with superior characteristics. Variable air capacitors are used more often because of their simple construction. They are usually made of two sets of semicircular metal plates separated by air gaps. One set is fixed and the other is attached to a shaft which allows the user to rotate the assembly, therefore changing the capacitance as needed. The larger the overlap between the two sets of plates, the higher the capacitance. The maximum capacitance state is achieved when the overlap between the two sets of plates is highest, while the lowest capacitance state is achieved when there is no overlap.

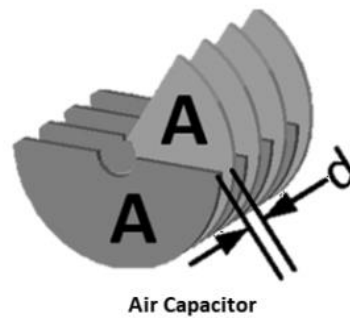

(Any one type)

2 marks for constructional diagram

2 marks for description

ii) Paper capacitors:

Paper capacitor is a capacitor that uses paper as the dielectric. It consists of aluminum sheets and paper sheets. The paper sheet is covered or soaked with oil or wax to protect it from outside harmful environment. Paper capacitors are the fixed type of capacitors that means these capacitors provides fixed capacitance. In other words, the paper capacitor is a type of fixed capacitor that stores fixed amount of electric charge.

Paper capacitors are classified into two types based on their construction:

- Paper sheet capacitor
- Metalized paper capacitor

Paper sheet capacitor:

The paper sheet capacitor is made by taking two or more aluminum sheets and placing a paper sheet between them. The paper placed between the aluminum sheets acts as dielectric and the aluminum sheets acts as electrodes.

The paper sheet is poor conductor of electricity so it does not allow flow of electric current or electric charges between two aluminum sheets. However, the paper sheet allows electric field through it. Therefore, the paper sheet placed between the aluminum sheets acts barrier for the electric current.

Model Answers

Winter – 2018 Examinations

Subject & Code: Fundamentals of Electrical Engineering (22212)

The paper sheets and aluminum sheets are rolled in the form of cylinder and wire leads are attached to both ends of the aluminum sheets. The entire cylinder is then coated with wax or plastic resin to protect it from moisture in the air. The paper sheet capacitors are used in the high voltage and high current applications.

Metalized paper capacitor:

In metalized paper capacitor, the paper is coated with thin layer of zinc or aluminum. The paper coated with zinc or aluminum is rolled in the form of cylinder. The entire cylinder is then coated with wax or plastic resin to protect it from moisture.

The zinc or aluminum coated on the paper acts as electrodes and the paper acts as dielectric. Paper capacitors that are made of zinc are easily destroyed due to the chemical action. Therefore, aluminum is widely used for the construction of paper capacitors.

The size of metalized paper capacitor is very small compared to the paper sheet capacitor. In metalized paper capacitor, the aluminum is directly coated on the paper. Therefore, aluminum layer of metalized paper capacitor is very thin compared to the aluminum layer of paper sheet capacitor.

Paper capacitor

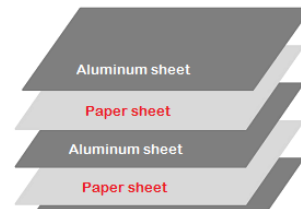

Paper capacitor

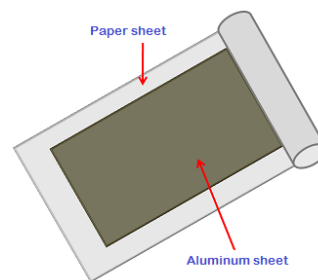

iii) Ceramic Capacitors:

Ceramic Capacitor is a capacitor that uses ceramic as the dielectric. Ceramic capacitors or Disc capacitors as they are generally called, are made by coating two sides of a small porcelain or ceramic disc with silver and are then stacked together to make a capacitor. For very low capacitance values a single ceramic disc of about 3-6mm is used. Ceramic capacitors have a high dielectric constant and are available so that relatively high capacitance can be obtained in a small physical size.

In order to gain higher capacitances, the capacitor can be made from multiple layers. The

Multi-Layer Ceramic Capacitors (MLCC) are made with Pseudoferroelectric and Ferroelectric materials mix and alternatively layered with metal contacts. After completion of the

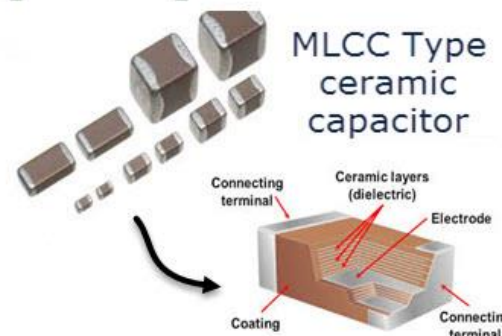
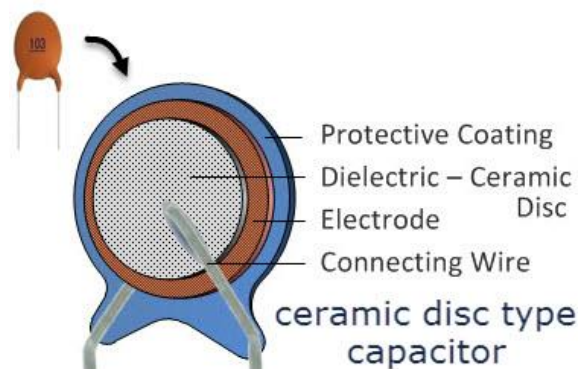

Model Answers
Winter – 2018 Examinations

Subject & Code: Fundamentals of Electrical Engineering (22212)

layering process, the device is brought to a high temperature and the mixture is sintered, resulting in a ceramic material of desired properties. Finally, the resulting capacitor basically consists of many smaller capacitors connected in parallel, this leads to increase in capacitance. The MLCCs consist of more than 500 layers, with the minimum layer thickness of approximately 0.5 microns. As technology progresses, the thickness of the layer decreases and capacitance increases in the same volume. Ceramic capacitor dielectrics vary from one manufacturer to another, but common compounds include titanium dioxide, Strontium Titanate, and Barium Titanate.

iv) Electrolytic capacitors:

The electrolytic capacitor uses an electrolyte (an ionic conducting liquid) as one of its plates to achieve a larger capacitance per unit volume than other types. The capacitors are able to increase the capacitance in a number of ways: increasing the dielectric constant; increasing the electrode surface area; and by decreasing the distance between the electrodes. Electrolytic capacitors use the high dielectric constant of the

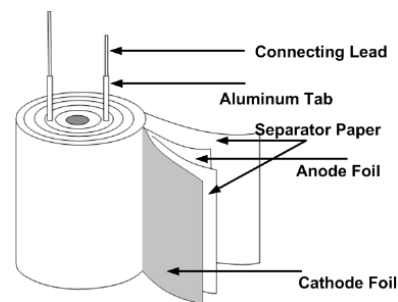

aluminium oxide layer on the plate of the capacitor which averages between 7 and 8. This is greater than other dielectrics such as mylar which has a dielectric constant of 3 and mica of around 6 - 8. In addition to this, the effective surface area within the capacitors is increased by a factor of up to 120 by roughening the surface of the high-purity aluminium foil. This is one of the keys to producing very high levels of capacitance. The plates of an electrolytic capacitor are constructed from conducting aluminium foil. As a result they can be made very thin and they are also flexible so that they can be packaged easily at the end of the production process. The two plates, or foils are slightly different. One is coated with an insulating oxide layer, and a paper spacer soaked in electrolyte is placed between them. The foil insulated by the oxide layer is the anode. The second foil acts as the cathode and although this does have a naturally occurring oxide layer, this is very much thinner. The thickness of the anode oxide thin film in an aluminium electrolytic capacitor is selected by the required working withstand voltage.

In order to package them the two aluminium foils with the electrolyte soaked paper are rolled together to form a cylinder, and they are placed into an aluminium can. In this way the electrolytic capacitor is compact while being robust as a result of the protection afforded by the can.

There are two geometries that are used for the connection leads or tags. One is to use axial leads, one coming from each circular face of the cylinder. The other alternative is to use two radial leads or tags, both of which come from the same face of the cylinder. The lead styles give rise to the descriptions used for the overall capacitors. To increase the surface area of both anode and cathode to increase the capacitance, the surface is roughened by etching.

v) Film Capacitor:

Film capacitors are capacitors which use a thin plastic film as the dielectric. Film

Model Answers

Winter – 2018 Examinations

Subject & Code: Fundamentals of Electrical Engineering (22212)

capacitors are made of a thin dielectric film which may or may not be metallized on one side. The film is extremely thin, with the thickness being under 1 μm . After the film is drawn to the desired thickness, the film is cut into ribbons. The width of the ribbons depends on the

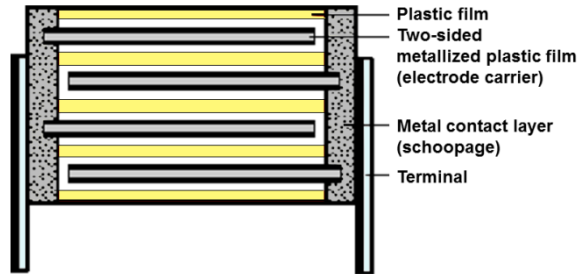

capacity of the capacitor being produced. Two ribbons of film are wound together into a roll, which is often pressed into an oval shape so that it can fit into a rectangular case. This is important because rectangular components save precious space on the printed circuit board. Electrodes are added by connecting each of the two electrodes to one of the films. A voltage is applied to burn out any imperfections using the self-healing property of film capacitors. The case is then sealed using silicon oil to protect the film roll against moisture, and dipped in plastic to hermetically seal the interior. This film is made extremely thin using a sophisticated film drawing process. Once the film is manufactured, it may be metallized or left untreated, depending on the needed properties of the capacitor. Electrodes are then added and the assembly is mounted into a case which protects it from environmental factors. They are used in many applications because of their stability, low inductance and low cost. There are many types of film capacitors, including polyester film, metallized film, polypropylene film, PTFE film and polystyrene film. The core difference between these capacitor types is the material used as the dielectric. PTFE film capacitors are heat-resistant and used in aerospace and military technology, while metallized polyester film capacitors are used in applications that require long term stability at a relatively low. Cheaper plastics are used if cost is a bigger concern than performance.

vi) Glass capacitors:

The capacitor consists of three basic elements: the glass dielectric, aluminium electrodes and the encapsulation. However the assembly of the glass capacitors is undertaken in a manner that ensures the required performance is obtained. As the capacitance between two plates is not always sufficient to provide

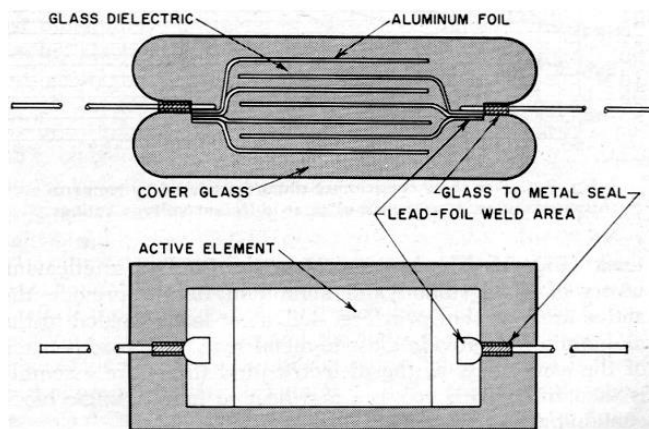

the required level of performance, the majority of capacitors use a multi-layer construction to provide several layers of plates with interspersed dielectric to give the required capacitance. Although the glass plates are always flat, and tubular forms of construction are not applicable, the glass capacitors are usually



Model Answers

Winter – 2018 Examinations

Subject & Code: Fundamentals of Electrical Engineering (22212)

available with leads emanating in either a radial or axial form. Essentially the leads either exit the encapsulation at the side or the end.

- 2 d) Distinguish between statically induced emf and dynamically induced emf.

Ans:

Distinction Between Statically & Dynamically Induced EMFs:

Statically induced emf	Dynamically induced emf
Emf is induced without any relative motion between conductor and magnetic field.	Emf is induced due to relative motion between conductor and magnetic field.
Emf is induced when changing magnetic field links with a conductor.	Emf is induced when conductor cuts the magnetic field due to relative motion between them.
Direction of statically induced emf is given by Lenz's law.	Direction of dynamically induced emf is given by Fleming's Right hand rule.
Two types: Self-induced emf Mutually induced emf	No such further classification
e.g. emf induced in transformer windings	e.g. emf induced in Generator, Alternator armature windings

1 mark for each of any 4 points = 4 marks

- 3 **Attempt any THREE of the following:**

12

- 3 a) Distinguish between Direct current and Alternating current. (Any four points)

Ans:

Distinction Between Direct Current and Alternating Current:

Particulars	Direct Current	Alternating Current
1. Waveform		
2. Definition	It is the current whose magnitude and direction do not change with respect to time.	It is the current whose magnitude and direction continuously changes with respect to time.
3. Use of transformer	Not possible	Possible
4. Distribution efficiency	Low	High
5. Design of the machines	Complicated	Simple
6. Generation	Mostly by electrochemical energy conversion and also by conversion of AC to DC using converters	Mostly by electromechanical energy conversion

1 mark for each of any 4 points = 4 marks



Model Answers

Winter – 2018 Examinations

Subject & Code: Fundamentals of Electrical Engineering (22212)

7. Applications	DC machines, electroplating, system, Battery charging	AC machines, Domestic and industrial supply
-----------------	---	---

OR Any other Equivalent Points

- 3 b) An electric heater is rated as 220 V, 800 watts. Calculate resistance and current through it. Determine the bill for using it for 4 hours at a rate of Rs. 4.5 per unit.

Ans:

Given Data: Rating of electric heater as: V=220 V, P=800 watts

$$\text{As } P = V^2 / R$$

1 mark

$$\text{Therefore } R = V^2 / P = (220)^2 / 800 = \mathbf{60.5 \Omega}$$

1 mark

$$\text{And } I = P / V = 800 / 220 = \mathbf{3.63 \text{ A}}$$

Bill for 4 hours at a rate of Rs. 4.5 per unit:

Energy consumed by heater for 4 hours in kwh = (Power x time in hrs.) / 1000

$$= (800 \times 4) / 1000 = 3200/1000 = \mathbf{3.2 \text{ kwh}}$$

1 mark

Bill at rate of Rs. 4.5 per unit in Rs. = kwh x Rate per unit = 3.2 x 4.5 = **Rs. 14.4**

1 mark

- 3 c) Define the following terms related to electric circuits.

- (i) Node
- (ii) Branch
- (iii) Loop
- (iv) Mesh

Ans:

Node: A point in an electric circuit at which different branches meet.

1 mark for

Branch: A part of an electric network which lies between two junctions or nodes.

each

Loop: A closed path for flow of current in an electrical circuit is called loop.

definition

Mesh: A set of branches forming a closed path for electric current in an electric circuit.

= 4 marks

OR A loop that does not contain any other loop.

- 3 d) Derive the expression for energy stored in capacitor with the help of a neat diagram.

Ans:

Energy stored in Capacitor:

Let C be the capacitance of a capacitor in farad.

v be the potential difference across capacitor in volt at a particular instant.

q be the charge on the capacitor at that instant.

Therefore, potential difference $v = \frac{q}{C}$ or charge $q = Cv$

When the potential difference across capacitor is v and if small amount of charge dq is shifted from one plate to other, the voltage is changed by dv. Therefore, $dq = C \cdot dv$

The work done in shifting a small charge dq against P. D. of v volt is given by,

$$dW = v \cdot dq = \left(\frac{q}{C}\right) dq \quad \text{OR} \quad dW = v \cdot dq = v \cdot C \cdot dv$$

The work done is stored as potential energy in the electrostatic field by the capacitor.

2 marks

Therefore, total energy stored by the capacitor is given by,

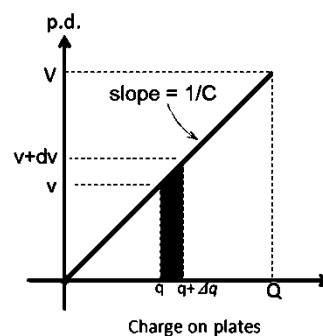

1 mark for diagram

Model Answers

Winter – 2018 Examinations

Subject & Code: Fundamentals of Electrical Engineering (22212)

$$\begin{aligned}
 E = \text{work done } W &= \int dW = \int \left(\frac{q}{c}\right) dq = \frac{1}{2c} q^2 \\
 &= \frac{1}{2} C \left(\frac{q}{c}\right)^2 = \frac{1}{2} C v^2 \quad \text{joule} && \text{1 mark} \\
 \text{Hence } W &= \int dW = \int C v dv = \frac{1}{2} C v^2 \quad \text{joule}
 \end{aligned}$$

4 Attempt any THREE of the following: **12**

4 a) Define Ideal voltage source and practical voltage source. Draw the symbol for Each.

Ans:

Ideal voltage source: A voltage source, whose terminal voltage always remains constant for all values of output current, is known as an ideal voltage source. It has zero internal resistance. 1 mark

Symbol of Ideal voltage source:

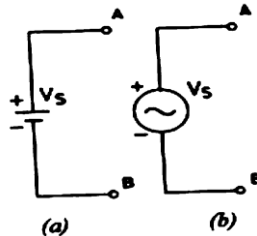

1 mark

Practical voltage source: A voltage source whose terminal voltage falls with the increase in the output current due to the voltage drop in the internal resistance.

Symbol of Practical voltage source:

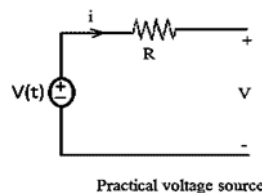

1 mark

4 b) Calculate the equivalent resistance between points A and D in Fig No.1

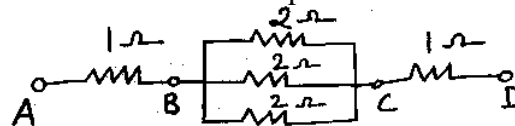

Fig. No. 1

Ans:

As resistances connected between points B and C (three resistances of 2Ω) are in parallel, therefore:

$$\begin{aligned}
 \frac{1}{R_{BC}} &= \frac{1}{R_1} + \frac{1}{R_2} + \frac{1}{R_3} && \text{1 mark} \\
 \frac{1}{R_{BC}} &= \frac{1}{2} + \frac{1}{2} + \frac{1}{2}
 \end{aligned}$$

$$\mathbf{R_{BC} = 0.666 \Omega} \quad \text{1 mark}$$

The resistances R_{AB} , R_{BC} & R_{CD} are connected in series, equivalent series resistance R_{AD} is given by



Model Answers

Winter – 2018 Examinations

Subject & Code: Fundamentals of Electrical Engineering (22212)

$$R_{AD} = R_{AB} + R_{BC} + R_{CD}$$

1 mark

Therefore

$$R_{AD} = 1 + 0.666 + 1 = 2.666 \Omega$$

1 mark

- 4 c) Three capacitors $1\mu\text{F}$, $2\mu\text{F}$ and $3\mu\text{F}$ respectively are connected in a circuit. Determine the equivalent capacitance when they are connected in-

- i) Series
- ii) Parallel

Ans:

Value of equivalent capacitance:

Given: $C_1 = 1\mu\text{F}$, $C_2 = 2\mu\text{F}$, $C_3 = 3\mu\text{F}$

i) For Series combination of capacitors:

$$\begin{aligned} 1/C_s &= (1/C_1) + (1/C_2) + (1/C_3) \\ &= (1/1) + (1/2) + (1/3) \end{aligned}$$

1 mark

$$1/C_s = 1 + 0.5 + 0.3333$$

$$1/C_s = 1.8333$$

$$\therefore C_s = 0.545 \mu\text{F}$$

1 mark

ii) For Parallel combination of capacitors:

$$C_p = C_1 + C_2 + C_3$$

1 mark

$$= 1 + 2 + 3 = 6 \mu\text{F}$$

1 mark

- 4 d) Describe the working of capacitor with a neat sketch.

Ans:

Working of Capacitor:

When we connect a battery (DC Voltage Source) across the capacitor, one plate (plate-I) gets attached to the positive terminal and another plate (plate-II) to the negative terminal of the battery.

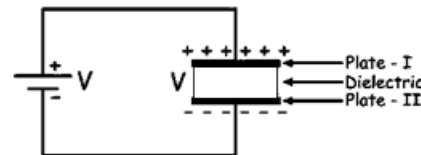

Now, the potential of that battery is applied across that capacitor. In this situation, the electrons from plate-I are attracted towards positive terminal of battery. When electrons move from plate-I, the net charge on plate-I becomes positive. The electrons received at positive terminal are then sent to plate-II. This work is done by the battery, hence its energy is transferred to the capacitor. The plate-II becomes negatively charged since it receives negatively charged electrons. Thus the current (flow of electrons) is observed external to the capacitor and not through the dielectric material between the plates.

4 marks for
stepwise
answer

An electric field appears across the capacitor. As time passes, plate-I becomes more & more positively charged by losing its electrons, whereas plate-II becomes more & more negatively charged by accepting the electrons from the battery. After some time, the capacitor holds maximum amount of charge as per its capacitance with respect to this voltage. This time span is called charging time of this capacitor. After disconnecting the battery from this capacitor, the two plates hold positive and negative charges for a certain time. Thus the charged capacitor acts as a source electrical energy.

- 5 **Attempt any TWO of the following:**

12

- 5 a) Draw B-H curve for magnetic material and state its nature. State the significance of hysteresis loop. Also draw the hysteresis loop for hard steel and soft steel.

Ans:

Model Answers

Winter – 2018 Examinations

Subject & Code: Fundamentals of Electrical Engineering (22212)

B-H Curve for Magnetic Material:

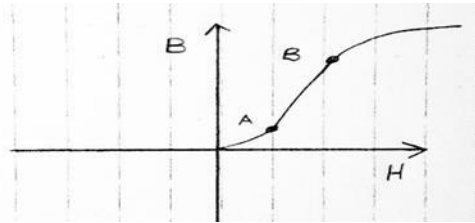

1 mark

Nature of B-H Curve: The B-H curve is concave up for low flux densities upto point A, for medium flux densities, it becomes straight (AB), for higher flux densities curve concaves down (after point B) Then almost becomes flat i.e. saturation occurs ultimately it is nonlinear curve.

1 mark

Significance of Hysteresis Loop:

The shape and size of the hysteresis loop largely depends on the nature of the magnetic material. The choice of a magnetic material required for a particular application often depends on the shape and size of the hysteresis loop.

The smaller the hysteresis loop area of a magnetic material, the less is the hysteresis loss. For example, the hysteresis loop area for silicon steel has very small, for this reason silicon steel is widely used for manufacturing of transformer cores and rotating machines which are subjected to rapid reversals of magnetism.

2 marks

The hysteresis loop for Hard Steel (large hysteresis loop area) indicates that the material has high retentivity and coercivity. Therefore hard steel is quite useful in making permanent magnets. But due to large area hysteresis loss is quite high. This is the reason hard steel is not used for construction of electrical machines.

Hysteresis Loop for Hard Steel and Soft Steel:

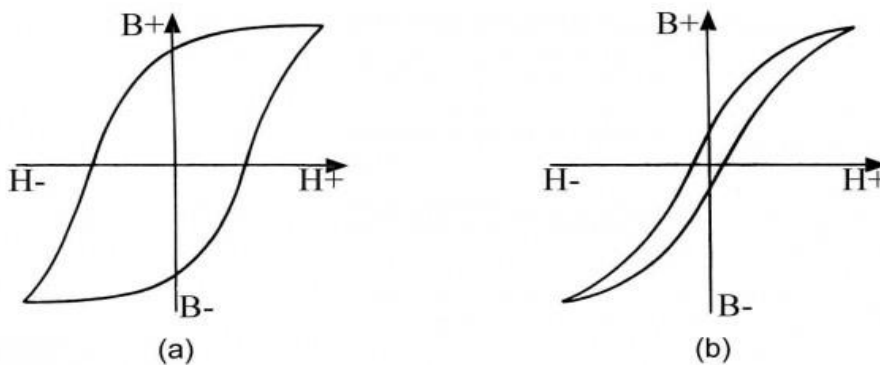

2 marks

Fig.(a) Shows hysteresis loop of hard steel & Fig.(b) Shows hysteresis loop of soft steel

- 5 b) An iron ring of mean circumference 100 cm is uniformly wound with 500 turns of wire. Calculate the value of flux density to produce a current of 1.1 Amp in the ring. Assume $\mu_r = 1200$.

Ans:

Given: Length of magnetic circuit $\ell = 100\text{cm} = 100 \times 10^{-2}\text{m}$, $N = 500$ Turns, $I = 1.1\text{A}$ & $\mu_r = 1200$

Assume $\mu_0 = 4\pi \times 10^{-7}$

Magnetic Field Strength:

1 mark for μ_0



Model Answers

Winter – 2018 Examinations

Subject & Code: Fundamentals of Electrical Engineering (22212)

$$H = NI / \ell \quad \text{1½ mark}$$

$$= \frac{500 \times 1.1}{100 \times 10^{-2}} = 550 \text{ AT/m} \quad \text{1 mark}$$

Flux Density:

$$B = \mu_0 \mu_r H \quad \text{1½ mark}$$

$$= 4\pi 10^{-7} \times 1200 \times 550 = 0.8293 \text{ T or Wb/m}^2 \quad \text{1 mark}$$

- 5 c) A coil consisting 100 turns is placed in the magnetic field of 0.3 mwb. Calculate the average emf induced in the coil when it is moved in 0.06 seconds from the given field ϕ to 0.1mwb. If the resistance of coil is 200Ω , find the induced current in the coil.

Ans:

Given $N=100$ turns, $\phi_1 = 0.3\text{mwb} = 0.3 \times 10^{-3}\text{wb}$, $t = 0.06$, $\phi_2 = 0.1 \times 10^{-3}\text{wb}$ & $R=200 \Omega$

Average induced emf $e = N \cdot \frac{d\phi}{dt}$ volt 1 mark

$$d\phi = (\phi_1 - \phi_2) = (0.3 - 0.1)\text{mWb} = 0.2 \text{ mWb} = 0.2 \times 10^{-3} \text{ Wb} \quad \text{2 marks}$$

$$dt = 0.06 \text{ second}$$

$$e = (100 \times 0.2 \times 10^{-3}) / 0.06 = \mathbf{0.333 \text{ volts}} \quad \text{2 marks}$$

As $R = 200 \Omega$

Current induced in the coil = $0.333 / 200 = \mathbf{0.001665\text{A or }1.665\text{mA}}$ 1 mark

- 6 **Attempt any TWO of the following:** **12**

- 6 a) Find the current through 5Ω resistor using Kirchoff's laws. (Fig No.2) Also state Kirchoff's current Law.

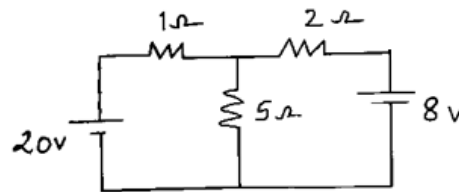
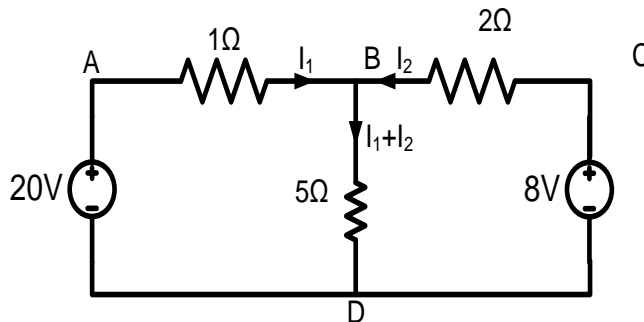

Fig. No. 2

Ans:

Mark the currents on the diagram as:



1 mark

Write KCL and KVL based equations

Consider loop ABDA,

$$(-1)I_1 - 5(I_1 + I_2) + 20 = 0$$

$$\therefore 6I_1 + 5I_2 = 20 \dots \dots \dots (1)$$

1 mark



Model Answers

Winter – 2018 Examinations

Subject & Code: Fundamentals of Electrical Engineering (22212)

Consider loop BCDB,

$$(2) I_2 - 8 + 5(I_1 + I_2) = 0$$

$$\therefore 5I_1 + 7I_2 = 8 \dots \dots \dots (2)$$

1 mark

Solving simultaneous equations

$$\therefore I_2 = -3.059 \text{ A} \dots \dots \dots (3)$$

1/2 mark

Substituting eqⁿ (3) in eqⁿ (1), we get

$$6I_1 - 15.29 = 20$$

$$\therefore I_1 = 5.88 \text{ A} \dots \dots \dots (4)$$

1/2 mark

Final answer

The current through 5Ω resistance is,

$$= I_1 + I_2 = 5.881 + (-3.059) = 2.821 \text{ A}$$

∴ 2.851 A flowing from B to D

1 mark

Kirchhoff's Current Law (KCL):

It states that in any electrical network, the algebraic sum of the currents meeting at a node (point or junction) is zero.

1 mark

i.e $\Sigma I = 0$

6 b) (i) State types of inductors.

(ii) A magnetic flux of 0.6mwb is passed through a coil of 1000 turns, is reversed in 0.05 seconds. Determine the average value of self-induced emf.

Ans:

Types of inductors:

- 1) Iron core inductors
- 2) Air core inductors
- 3) Ferrite core inductors

1 mark for each type = 3marks

Average Value of Self-induced EMF:

$$\text{Average value of self-induced emf } (e) = N \cdot \frac{d\phi}{dt} \text{ volt}$$

1 mark

$$d\phi = (0.6 - (-0.6))\text{mWb} = 1.2 \text{ mWb} = 1.2 \times 10^{-3} \text{ Wb}$$

1 mark

$$dt = 0.05 \text{ second}$$

$$e = (1000 \times 1.2 \times 10^{-3}) / 0.05 = \mathbf{24 \text{ volts}}$$

1 mark

6 c) The field winding of a d.c. electromagnet is wound with 960 turns and has resistance of 50Ω when the exciting voltage is 230 V, the magnetic flux linking the coil is 0.005 wb. Calculate the self inductance of a coil and the energy stored in magnetic field.

Ans:

Given: N = 960 turns , R = 50Ω , V = 230 V, $\phi = 0.005\text{wb}$

$$\text{Current} = V/R = 230 / 50 = 4.6\text{A}$$

$$\text{Self-Inductance } L = \frac{N\phi}{I}$$

2marks

$$= \frac{960 \times 0.005}{4.6} = \mathbf{1.0434 \text{ henry}}$$

1 mark

Energy stored in magnetic field

$$E = \frac{1}{2} LI^2 \text{ joule} = \frac{1}{2} \times 1.0434 \times 4.6^2 = \mathbf{11.039 \text{ J}}$$

3marks