



**SUMMER- 18 EXAMINATION**

**Subject Name: BUILDING DRAWING**

**Model Answer**

Subject Code:

**17309**

**Important Instructions to examiners:**

- 1) The answers should be examined by key words and not as word-to-word as given in the model answer scheme.
- 2) The model answer and the answer written by candidate may vary but the examiner may try to assess the understanding level of the candidate.
- 3) The language errors such as grammatical, spelling errors should not be given more Importance (Not applicable for subject English and Communication Skills).
- 4) While assessing figures, examiner may give credit for principal components indicated in the figure. The figures drawn by candidate and model answer may vary. The examiner may give credit for any equivalent figure drawn.
- 5) Credits may be given step wise for numerical problems. In some cases, the assumed constant values may vary and there may be some difference in the candidate's answers and model answer.
- 6) In case of some questions credit may be given by judgement on part of examiner of relevant answer based on candidate's understanding.
- 7) For programming language papers, credit may be given to any other program based on equivalent concept.

Q. No.	Sub Q. N.	Answers	Marking Scheme																		
1.	a) (i)  Ans	<p>Attempt any THREE of the following: Draw graphical symbols for, 1) Stone masonry 2) Brick masonry 3) Single shutter double swing door 4) Glass</p> <table border="1"> <thead> <tr> <th>Sr. No.</th> <th>Item</th> <th>Symbol</th> </tr> </thead> <tbody> <tr> <td>1.</td> <td>Stone Masonry</td> <td></td> </tr> <tr> <td>2.</td> <td>Brick masonry</td> <td></td> </tr> <tr> <td colspan="3" style="text-align: center;">S : Section E : Elevation,</td> </tr> <tr> <td>3.</td> <td>Single shutter double swing door</td> <td></td> </tr> <tr> <td>4.</td> <td>Glass</td> <td></td> </tr> </tbody> </table>	Sr. No.	Item	Symbol	1.	Stone Masonry		2.	Brick masonry		S : Section E : Elevation,			3.	Single shutter double swing door		4.	Glass		04 Marks (01 M for each)
Sr. No.	Item	Symbol																			
1.	Stone Masonry																				
2.	Brick masonry																				
S : Section E : Elevation,																					
3.	Single shutter double swing door																				
4.	Glass																				
1.	a)(ii)  Ans	<p>Draw neat sketches for following lines: 1) Centre line 2) Hidden line 3) Construction line. 4) Section line</p>																			



	<table border="1" style="width: 100%; border-collapse: collapse;"> <tr> <td style="width: 30%;">Visible Outlines-Thick</td> <td style="width: 40%; text-align: center;"> </td> <td style="width: 30%; text-align: right;">0.80 mm to 1.30 mm</td> </tr> <tr> <td rowspan="2">Centre Lines-Thin</td> <td style="text-align: center;"> <p style="font-size: small; text-align: center;">6 : 1                      4 : 1 Long dash 6 : Short dash 1</p> </td> <td rowspan="2" style="text-align: right; vertical-align: middle;">0.2 mm to 0.3 mm thick</td> </tr> <tr> <td style="text-align: center;"> <p style="font-size: small; text-align: center;">4 : 1 Long dash 4 : Short dash 1</p> </td> </tr> <tr> <td>Hidden Lines-Medium</td> <td style="text-align: center;"> </td> <td style="text-align: right;">0.4 mm to 0.5 mm thick</td> </tr> <tr> <td>Section Lines</td> <td style="text-align: center;"> <p style="font-size: small; text-align: center;">Alternate two short-one long dashes</p> </td> <td style="text-align: right;">0.6 mm to 1 mm thick</td> </tr> </table>	Visible Outlines-Thick		0.80 mm to 1.30 mm	Centre Lines-Thin	<p style="font-size: small; text-align: center;">6 : 1                      4 : 1 Long dash 6 : Short dash 1</p>	0.2 mm to 0.3 mm thick	<p style="font-size: small; text-align: center;">4 : 1 Long dash 4 : Short dash 1</p>	Hidden Lines-Medium		0.4 mm to 0.5 mm thick	Section Lines	<p style="font-size: small; text-align: center;">Alternate two short-one long dashes</p>	0.6 mm to 1 mm thick	
Visible Outlines-Thick		0.80 mm to 1.30 mm													
Centre Lines-Thin	<p style="font-size: small; text-align: center;">6 : 1                      4 : 1 Long dash 6 : Short dash 1</p>	0.2 mm to 0.3 mm thick													
	<p style="font-size: small; text-align: center;">4 : 1 Long dash 4 : Short dash 1</p>														
Hidden Lines-Medium		0.4 mm to 0.5 mm thick													
Section Lines	<p style="font-size: small; text-align: center;">Alternate two short-one long dashes</p>	0.6 mm to 1 mm thick													

04 M  
(01 M for each)

1. a)(iii)  
Ans

Define aspect and prospect and give one example for each.

1) Aspect: Aspect can be defined as the direction from which the room receives the benefits from the natural parameters available to us from the surrounding area. It can be also defined as the positioning of windows and doors in the external walls to take maximum advantages of natural gifts such as sunlight and wind movement or breeze. Various rooms in the building have to follow different function and they have different requirements and hence the aspect changes as per the rooms.

e.g. Kitchen should have its windows in eastern walls. As the morning sunlight will enter in the kitchen and as the morning sunlight has germ killing UV rays, the Kitchen can be more hygienic in this way. Thus Kitchen has Eastern aspect.

Similarly Bedrooms have the west or south west aspect as in the Winter, the sun is towards south, so the bedrooms will remain warm and during summer, the sun is towards north, so the bedrooms will remain cool. Also West is the general direction from which breeze blows during evening and night. Thus Bed room has South or South-West aspect.

2)Prospect : Prospect means taking advantages of desirable views available from windows , doors and balconies, of features outside the building such gardens, lake, sea, river, hill etc. Prospect also means blocking of undesirable views, such as garbage dumping yard, slum area, ponds or gutters, railway track, cremation ground etc. by providing blank wall without windows towards the undesirable views.

Prospect is important in residential buildings and also in public buildings like hotels, resorts etc. For example, rooms with sea-side prospects in a beach resort always have higher rents. Flat with lake prospect always sell at higher prices. Arrangement of balconies for lake-side, or hill-side resort. Blocking of garbage dumping area by blank wall. Better prospects can be achieved by providing larger windows, bay window or corner windows also. It is the view desired from a particular room when seen outside the window. Depends on surrounding revilement of some natural beautiful pleasant scenery. Concealing the unwanted views. Placement of doors and windows in external walls affects prospect.

04 M  
(02 M each)

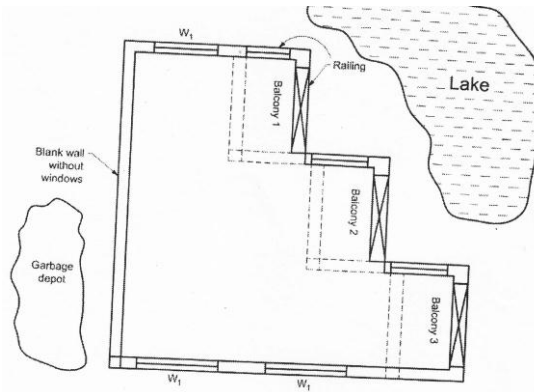

1. a)(iv) Give the values of minimum dimensions for,  
 1) Habitable room                      2) Kitchen                      3) WC                      4) Head room  
 Ans 1) Habitable room : Minimum Area-  $9.5\text{m}^2$  (for single room), Minimum width- 2.4 m , Minimum Height – 2.75 m.  
 2) Kitchen - Minimum Area –  $5.5\text{m}^2$ , Minimum width – 1.8 m. (for Kitchen –cum- store), and Minimum Area –  $9.5\text{m}^2$ , Minimum width – 2.4 m. (for Kitchen –cum- dining)  
 3) WC - Minimum area –  $1.1\text{m}^2$ , Minimum width - 0.9 m., Minimum height – 2.2 m  
 4) Head Room- 1.8 m (minimum) Minimum Head room in a passage under the landing – 2.2 m.

04 M  
(01 for each)

1. b) Draw to suitable scale line plan of bank building located at district place.

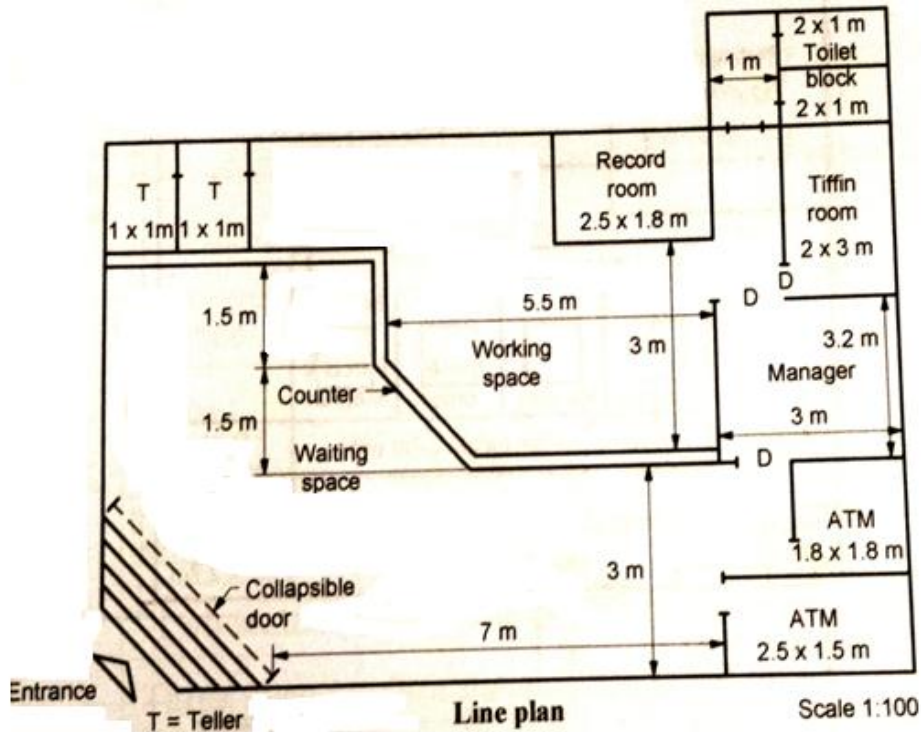

Correct line plan 03 – marks  
 labeling-02 marks  
 dimension 02–marks,  
 neatness 01 - mark

2. b) Attempt the following:

Figure no. 1 shows a line plan of a residential building. Draw to scale of 1 :50 the following views, show all dimensions and label the parts. (Refer Page No.3)

- a) Developed plan
- b) Front elevation
- c) Section AB

Use following data:

- 1) Depth of foundation 1.2 m below GL.
- 2) Plinth height 0.750 m
- 3) Ceiling height 2.85 m
- 4) RCC slab 0.12 m thick
- 5) Wall thickness 0.30 m and for toilets 0.20 m thick
- 6) Chajja 0.45 m projection
- 7) Assume suitable data if required.

Ans

a) Developed plan

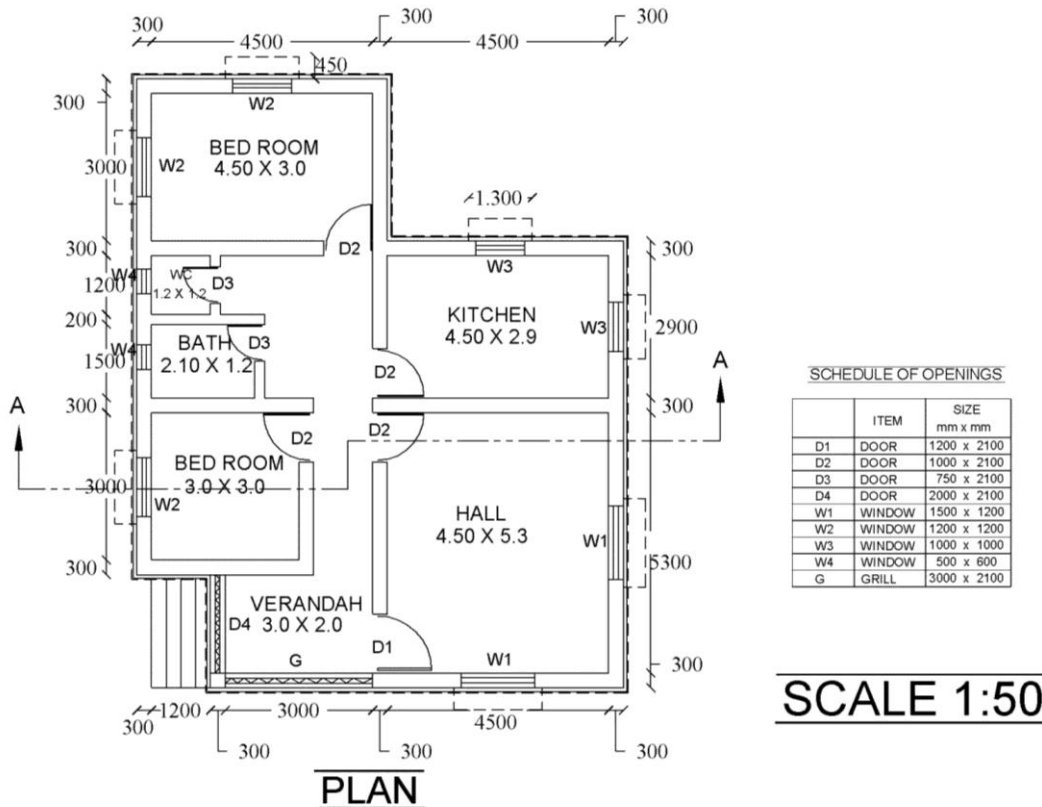

developed  
plan 04  
marks

labeling-  
02marks,  
dimensions  
02 marks,

doors and  
windows 02  
marks

neatness 01  
mark

Scale 01  
mark

2.

b) Front

elevation

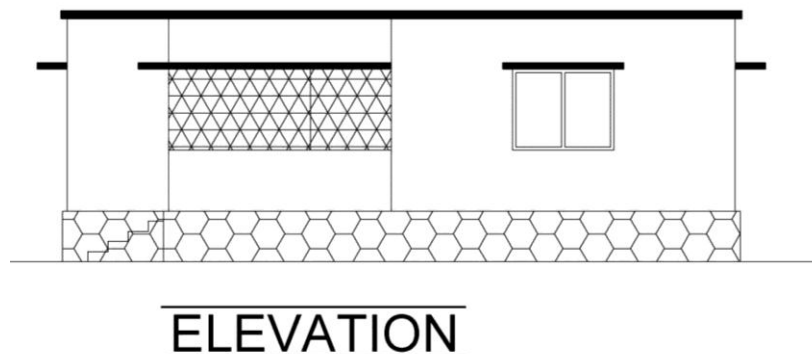

Correct  
elevation 06  
marks,

Neatness 01  
marks)

Scale 01

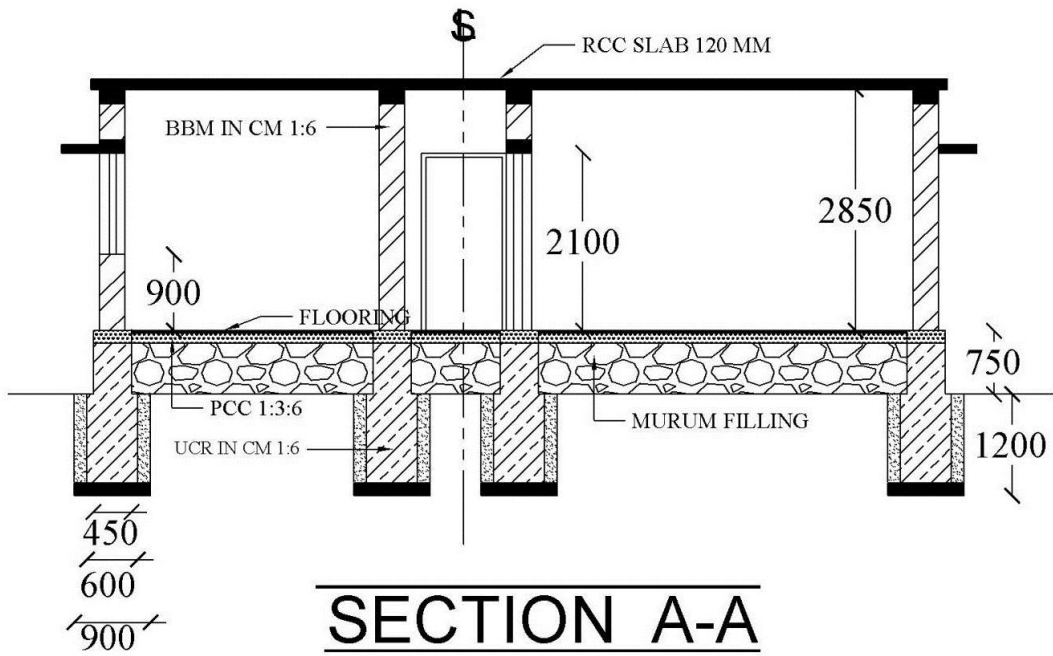
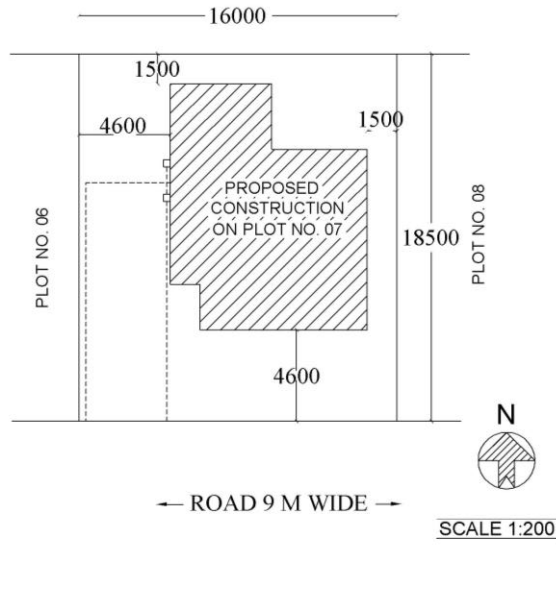
		mark
2.	<p>c) Section AB</p>  <p style="text-align: center;"><b>SECTION A-A</b></p> <p style="text-align: center;"><b>ALL DIMENSIONS ARE IN MM</b></p> <p>Note: In question paper, section line AB is not shown. Hence students may take different section line. So assess the answer as per that section line.</p>	<p>Correct section 04 marks</p> <p>all dimension 01 marks,</p> <p>material symbol 02marks</p> <p>Scale 01 mark</p>
3.	<p>a) Attempt any THREE of the following: Prepare site plan for Figure No. 1 having plot size 16 m x 18.5 m. Road fronting 16m having 9m width and north along 18.5 m size.</p> <p>Ans</p>  <p style="text-align: center;"><b>SITE PLAN</b></p>	<p>Correct site plan 04 M ,</p> <p>site margins 01 M,</p> <p>Water and Sewer line 01 M,</p> <p>Scale 01 M,</p> <p>neatness 01 M</p>



3. b) Prepare area statement with key area block diagrams with FSI calculations.  
Ans.

Sr. No.	PARTICULAR	BLOCK DIAGRAM	NOS.	SIZE	AREA
1.	HALL		1	4.50m x 5.30m	23.85 Sq.m.
2.	BED ROOM 1		1	3.0m x 3.0m	9.0 Sq.m.
3.	BED ROOM 2		1	4.50m x 3.0m	13.50 Sq.m.
4.	KITCHEN		1	4.50m x 2.90m	13.05 Sq.m.
5.	CARPET AREA	TOTAL OF HALL & BED ROOM AREA	1	23.85 + 9.0 + 13.50	46.35 Sq.m.
6.	BUILT-UP AREA		1	$= ((5.25m + 4.8m) \times (10.25m + 2.3m)) - (4.8m \times 3.3m) - (2.30m \times 1.8m)$	106.15 Sq.m.
7.	PLOT AREA		1	16.0m x 18.5m	296.00 Sq.m.
8.	F.S.I.	$\frac{\text{BUILT UP AREA}}{\text{PLOT AREA}}$	1	$\frac{106.15 \text{ Sq.m.}}{296.00 \text{ Sq.m.}}$	0.359

08 M (All eight point with block diagram 01 M each)

3. c) Suggest various units required for hostel building having 100 beds.  
Ans For hostel building having 100 beds following units are required:

Sr. No.	Description of unit	Area or Size	Number
1	Entrance	3.0 m wide	1 No.
2	<b>Rooms</b>		
	(a) Single seater rooms	10 sq. m. to 15 sq. m.	100 Nos.
	(b) Double seater rooms	15 sq. m. to 20 sq. m.	50 Nos.
	(c) Three seater rooms	20 sq. m. to 25 sq. m.	34 Nos.
	(d) Four seater rooms	25 sq. m. to 36 sq. m.	25 Nos.
3	Warden's office	20 sq. m. to 30 sq. m.	1 No.
4	Dining hall	1.2 sq. m. per diner	1 No.
5	Kitchen with store	8 sq. m. to 12 sq. m.	1 No.
6	Recreation hall	2 to 3 sq. m. / head	1 No.
7	Circulation	1.0 m to 2.0 m wide	Corridor etc.
8	<b>Sanitary units</b>	<b>Male</b> <b>Female</b>	<b>Male</b> <b>Female</b>
	(a) Water Closets	1 for 10      1 for 8	10 Nos.      13 Nos.
	(b) Baths	1 for 10      1 for 10	10 Nos.      10 Nos.
	(c) Urinals	1 for 25      ---	4 Nos.      ---
	(d) Wash basins	1 for 10      1 for 10	10 Nos.      10 Nos.

08 M for all eight point with area or number 01 M each

3. d) Draw detailed plan and section of RCC column and column footing with following data:  
(i) Size of footing - 1200 x 1200 mm      (ii) Size of column - 300 x 300 mm

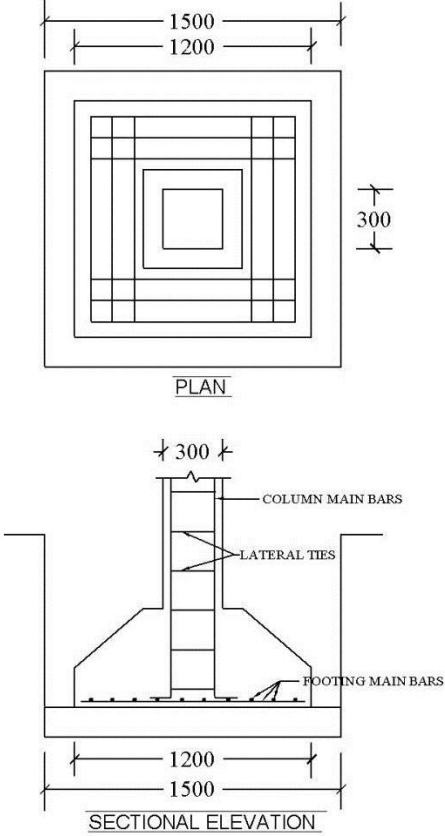

<p>Ans</p>	 <p>PLAN</p> <p>SECTIONAL ELEVATION</p>	<p>for neat and suitable plan -03 M</p> <p>for suitable Section -03 M</p> <p>dimensioning and labeling-02 M</p>
<p>4.</p>	<p>a)</p> <p>Ans</p> <p>Attempt any TWO of the following</p> <p>Explain procedure of getting approval for building construction from competent authority.</p> <p>Following procedure should be adopted for getting approval for building construction from competent authority.</p> <p><b>1) Notice:</b> - Every person who intends to carry out development and erect, re-erect or make alterations in any place in a building or demolish any building, shall give notice in writing to the Planning Authority of his said intention in the prescribed form and such notice shall be accompanied by the payment receipt of required scrutiny fee and any other fee/ charges prescribed by the Planning Authority from time to time and the plans and Statements in sufficient copies. The plans may be ordinary prints on Ferro paper or any other type (prints only). One set of plans shall be retained in the office of the Planning Authority for record after the issue of permit or refusal. For the sake of scrutiny, the plans may be submitted in the form of soft copy as specified by the Planning Authority from time to time.</p> <p><b>2) Copies of Plans and Statements:</b> - Minimum four copies of plans and statements shall be made available along with the notice. In case of building schemes, where clearance is required from other agencies like Fire Services, number of copies of plans required shall be as decided by the Chief Officer.</p> <p><b>3) Information Accompanying Notice:</b> - The notice shall be accompanied by the key (location plan), site plan, sub-division layout plan, building plan, services plans, specifications and Certificate of supervision and ownership title as prescribed in Regulation</p>	<p>1/2 M for each point</p>





**4) Ownership title and area:** - Every application for development permission and commencement certificate shall be accompanied by the following documents for verifying the ownership and area etc. of the land:-  
(a) Attested copy of original registered sale / lease - deed / power of attorney / enabling Ownership document wherever applicable.  
(b) V.F.No.7/12 extracts or property register card of a date not more than six months prior to the date of submission and a certified copy of the Measurement Plan of the property under Development proposal.  
(c) Statement of area of the holding by triangulation method from the qualified licensed Technical personnel or architect with an affidavit from the owner with regard to the area in The form prescribed by the Chief Officer.  
(d) Any other document prescribed by the Chief Officer.  
(e) Wherever third party interest is created by way of agreement to sale or mortgage etc. the Registered consent of such interested persons shall be submitted with the application.  
(f) A certified copy of approved sub-division / amalgamation / layout of land from the Concerned authority.

**5) Key Plan or Location Plan:** - A key plan drawn to a scale of not less than 1:10,000 shall be Submitted as a part of building plan / development proposal along with the application for a Building permit and commencement certificate; showing the boundary and location of the site With respect to neighborhood landmarks or with respect to the area within the radius of 200 from the site, whichever is more.

**6) Site Plan:** The site plan shall be submitted with an application for building permission drawn to scale of 1:500 or more as may be decided by the Chief Officer. This plan shall be based on the measurement plan duly authenticated by the appropriate officer of the Department of Land Records.

**7) Sub - Division/ Layout Plan:** - In the case of development of land, the notice shall be Accompanied by the sub -division/ layout plan which shall be drawn to a scale of not less than 1:500, however, for layout having areas of 4.0 ha. And above, the plan shall be drawn to a scale of not less than 1:1000.

**8) Building Plan:-** The plans of the buildings with elevations and sections accompanying the notice shall be drawn to a scale of 1:100.

**9) Service Plan:-** Plans, elevations and sections of private water supply, sewage disposal system and details of building services, where required by the Authority, shall be made available on a scale not less than 1:100 in general and 1:1000 for layouts.

**10) Specifications** - General specifications of the proposed constructions, giving type and grade of materials to be used.

**11) Supervision** - The notice shall be further accompanied by a certificate of supervision in the prescribed form by a licensed Architect/ Engineer/ Structural Engineer.

**12) Building Permit Fee:-** The notice shall be accompanied by an attested copy of Receipt of payment of Building Permit Application Fee.

**13) Security Deposit Fee:-** For ensuring faithful compliance of regulations and the directions given in the sanctioned plan and other terms and conditions, a security fee





	<p>shall be charged at rates as specified by the Chief Officer.</p> <p><b>14) No Objection Certificate:-</b> In case of development / construction of buildings requiring Clearance from the authorities like Civil Aviation Authority, Railways, Directorate of Industries, Maharashtra Pollution Control Board, District Magistrate, Inspectorate of Boilers and Smoke Nuisance, defence Authorities, Maharashtra Coastal Zone Management Authority, Archeological Department etc. The relevant no objection certificates from these authorities, applicable to the occupancy, shall also accompany the application.</p> <p><b>15) Signing the Plan:-</b>All the plans shall be duly signed by the owner, co-owner, if any, and the Architect or Licensed Engineer / Structural Engineer / Supervisor and shall indicate his name, Address and license number allotted by the Chief Officer.</p>	
4.	<p>b) Explain importance of following principles of planning with example: (i) Roominess (ii) Privacy</p> <p>Ans <b>(i) Roominess:</b> it is a psychological feeling about bigness or smallness of space e.g. of a room, is called as roominess. The length to breadth ratio 1.5:1 to 2:1 is good for roominess. If length increased beyond this, then a bad effect known as tunnel effect sets in making the room appear even longer than it actually is.</p> <p>The height of a room also plays an important part in roominess and a low ceiling gives cramped feeling. The height should be such that we have to look up sufficiently to see the junction of wall and ceiling. If the junction line of wall and ceiling is visible while standing up or by slightly turning the eyes up without turning the head up it will give a cramped feeling to the room.</p> <p>But if the height is too much, it will give rise to a bad effect known as chimney effect ,where the room appears even higher than it actually is and one gets uneasy feeling as if one is standing at the bottom of high, hollow chimney. A trapezoidal room appears roomier than a rectangular one.</p> <p><b>(ii) Privacy:</b> there are two considerations to the principle of privacy</p> <p><b>a) External privacy:</b> this means privacy of the entire building from surrounding buildings. Privacy from noise and pollution from the road. Also privacy from congestion due to crowding of buildings. External privacy can be maintained by good planning, for example, very low sill height of windows in the external walls will disturb privacy. Hence sill height must be kept sufficiently high. Empty spaces around the building, properly planned will ensure that the building is properly isolated and has sufficient privacy. Raising the sill height of W.C. and bath further than the rest of the windows is also a measure for privacy .building a compound wall and growing trees around the house prevents the street noise, dust and pollution to enter the house. These are the various measures to ensure external privacy.</p> <p><b>b) Internal privacy:</b> this means prevention of direct view inside any room from any other room or from passage. Proper placements of doors ensure the internal privacy. staging of the doors, instead of all doors in a straight line, proper placing of the shutters of the</p>	<p>04 M</p> <p>02 M</p> <p>02 M</p>

doors, using single shutters doors instead of double shutter doors, use of screens, proper furniture arrangement, etc are some measure to ensure internal privacy.

4. c)  
Ans

Draw foundation plan for Figure No. 1.

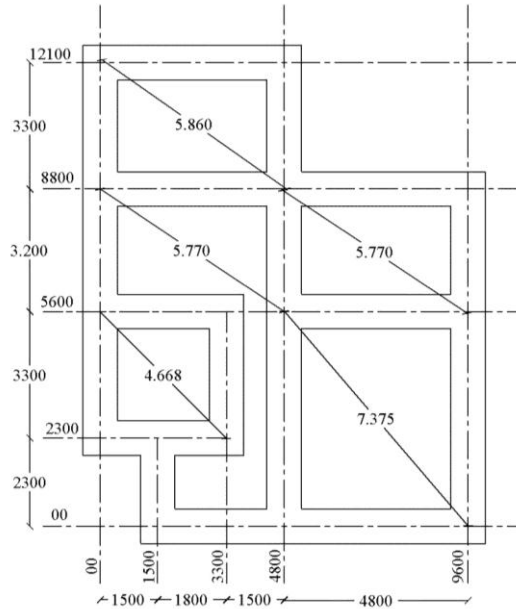

**FOUNDATION PLAN**

**ALL DIMENSIONS ARE IN MM**

Correct plan  
04 M  
  
all dimension  
02 M,  
  
neatness 01  
M  
  
Scale 01 M

5. a)  
Ans

Figure No. 2 shows a plan and elevation of small structure: Assume eye level at 1.80 m above G.L., draw to suitable scale two point perspective view and retain all construction lines.

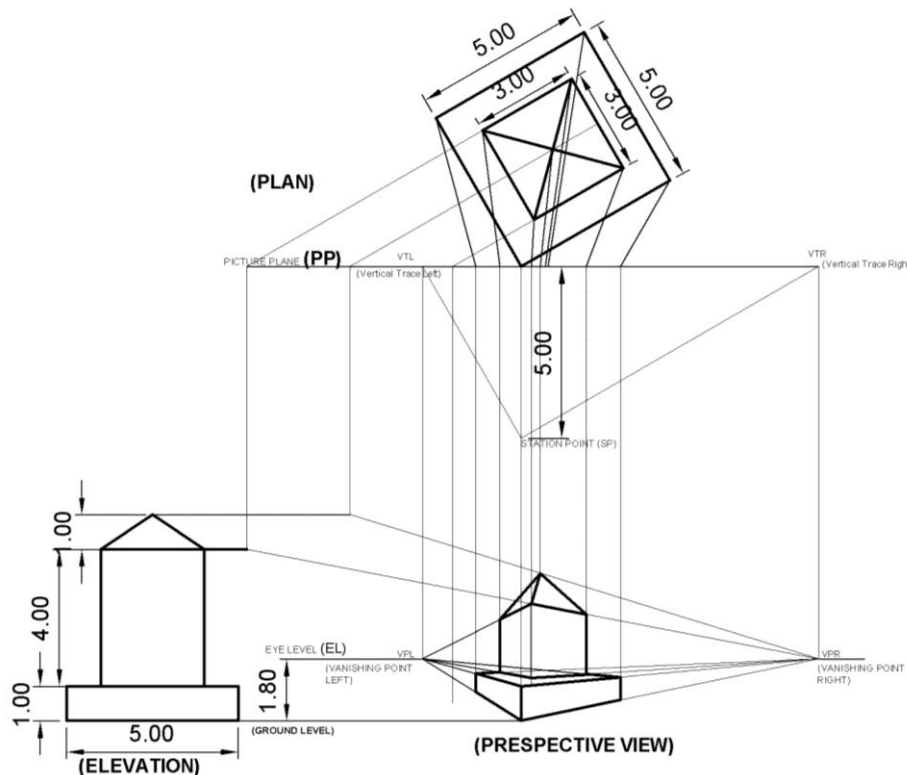

02 marks for plan,  
  
01 mark for elevation,  
  
02 marks for construction lines,  
  
01 mark for eye level  
  
01 mark station point  
  
05 marks for correct object



5. a)  
OR  
Ans

Draw perspective view of given object from Figure No. ,3.

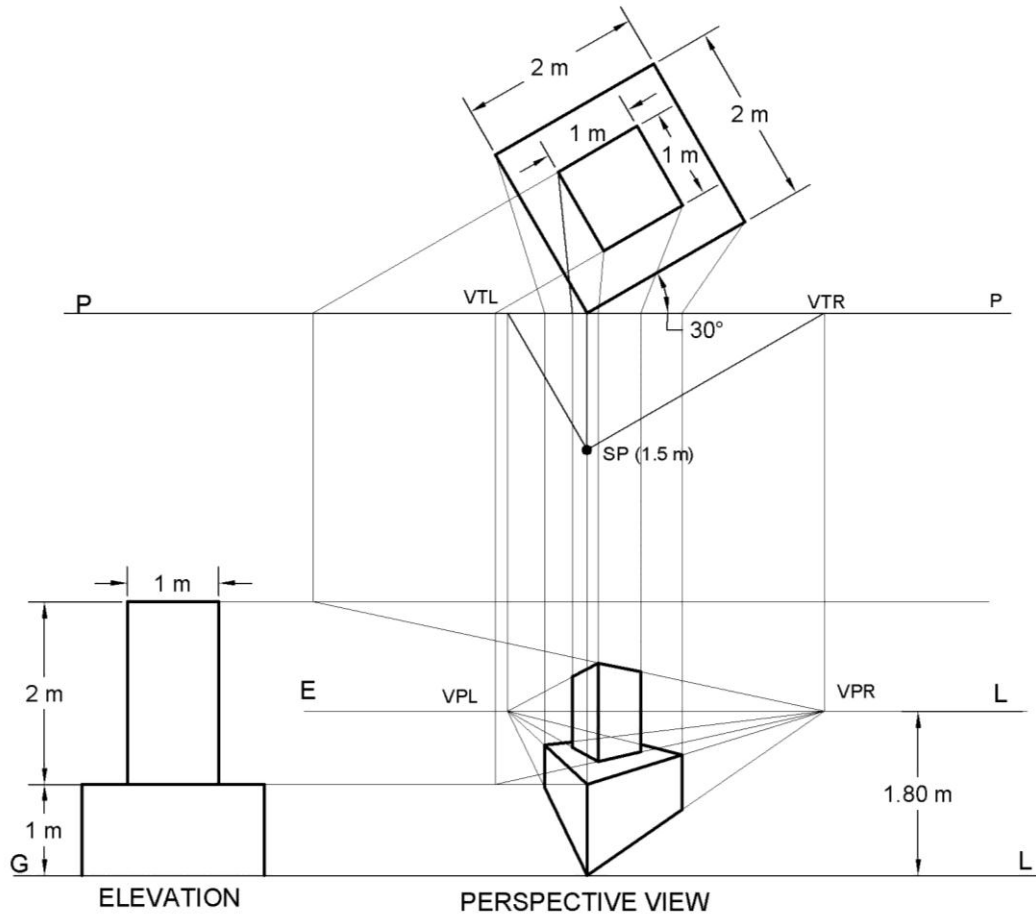

02 marks for plan,

01 mark for elevation,

02 marks for construction lines,

01 mark for eye level

01 mark station point

05 marks for correct object