



WINTER– 18 EXAMINATION

Subject Name: Production Engineering and Robotics Model Answer

Subject Code **17609**

Important Instructions to examiners:

- 1) The answers should be examined by key words and not as word-to-word as given in the model answer scheme.
- 2) The model answer and the answer written by candidate may vary but the examiner may try to assess the understanding level of the candidate.
- 3) The language errors such as grammatical, spelling errors should not be given more Importance (Not applicable for subject English and Communication Skills).
- 4) While assessing figures, examiner may give credit for principal components indicated in the figure. The figures drawn by candidate and model answer may vary. The examiner may give credit for any equivalent figure drawn.
- 5) Credits may be given step wise for numerical problems. In some cases, the assumed constant values may vary and there may be some difference in the candidate's answers and model answer.
- 6) In case of some questions credit may be given by judgement on part of examiner of relevant answer based on candidate's understanding.
- 7) For programming language papers, credit may be given to any other program based on equivalent concept.

Q. No.	Sub Q. N.	Answer	Marking Scheme													
1	a		Four points.1Mark each													
	i	<table border="1"> <thead> <tr> <th>Factor</th> <th>Job Production</th> <th>Mass Production</th> </tr> </thead> <tbody> <tr> <td>Product</td> <td>Unique</td> <td>Standard-identical</td> </tr> <tr> <td>Machine</td> <td>Std. Machinery depending upon whether the factory is engaged in light, medium or heavy engg. General Purpose</td> <td>Machinery designed for one range of product. Special Purpose</td> </tr> <tr> <td>Layout</td> <td>Process or functional Layout</td> <td>Line Layout or Product Layout</td> </tr> <tr> <td>Example</td> <td>Ship building, Process Equipment, Casting, turbo generators, boilers</td> <td>Food, T.V, Electric Lamps vehicles, glass mfg, sugar mills.</td> </tr> </tbody> </table>		Factor	Job Production	Mass Production	Product	Unique	Standard-identical	Machine	Std. Machinery depending upon whether the factory is engaged in light, medium or heavy engg. General Purpose	Machinery designed for one range of product. Special Purpose	Layout	Process or functional Layout	Line Layout or Product Layout	Example
Factor	Job Production	Mass Production														
Product	Unique	Standard-identical														
Machine	Std. Machinery depending upon whether the factory is engaged in light, medium or heavy engg. General Purpose	Machinery designed for one range of product. Special Purpose														
Layout	Process or functional Layout	Line Layout or Product Layout														
Example	Ship building, Process Equipment, Casting, turbo generators, boilers	Food, T.V, Electric Lamps vehicles, glass mfg, sugar mills.														
	ii	<p>Techniques for improving productivity</p> <p>1) Work Study:- It aims ,one to find out the best method of doing job and another one is to find the time taken to do it. This is done by breaking down the job into its various elements, eliminating all unnecessary movements and estimating the time taken to do this job with the help of stopwatch. Second aim is to ensure that all workers engaged in the job are trained to do it in the best way.</p>	Any four.1 mark each													



		<p>2) Human Relations:- Help in co-operative behavior from workers which results in increase in productivity. It can be improved by labour participation in goal setting, simplification in communication system, minimizing the conflicts, encouragement and awarding rewards etc.</p> <p>3) Incentives:- It results a considerable improvement in productivity. It encourages a worker to put in more productive effort. It is a kind of financial or non financial reward which is closely related to the performance of worker, resulting increase in wages corresponding to an increase in output.</p> <p>4) Cost Control:- Productivity can be increased by reducing the cost of production. This can be done by keeping careful watch over expenditure ,reduction in wastage, reducing machine breakdown time etc.</p> <p>5) Product Design:- A good product design helps in economical and convenient manufacturing. It will also minimize wastage or scrap and reduce the cost of production. It is simple to understand, reduces ineffective time and must consider the current available technology.</p> <p>6) Ergonomics:-It is designing the man machine system in such a way that to ensure high productivity and safety of workers.</p> <p>7) Management by Objectives:-It is a style of managing an organization which gives stress on the achievement of results expressed in terms of objectives. Jointly superior and subordinates management identify common goals and define individuals responsibility in terms of results expected from him.</p> <p>8) TQM:-Total Quality Management set the activities involving everybody in an organization in a totally integrated efforts improving performance at every level. Effective TQM results in grater customer satisfaction, fewer defects, less waste, improved profitability and increased productivity.</p> <p>iii Productivity Index:- It is used to compare the productivity during the current year with the productivity during the base year. Base year is any year which the company users or comparative study.</p> <p>1.Labour Productivity:-Output can be measured in total quantity produced and labour can be measured in total man hours required to produce that output. This index is relatively free of changes caused by wage rates and labour mix.</p> <p>2.Machine Productivity :- Output can be measured in total quantity produced and machine can be measured in total machine hours required to produce that output.</p> <p>3.Material Productivity:--The Productivity o the materials becomes key actor in economic production/operation..It is Number o units produced per cost o material.</p> <p>iv Concept of line balancing:- A production line is said to be in balance when every worker's task takes the same amount of time. Line balancing is a manufacturing-engineering function in which whole collection of production-line tasks are divided into equal portions. Well-balanced lines avoid labour idealness and improve productivity.</p>	<p>1 mark for Definition and 1 mark for each term.</p> <p>Explanation-4 marks</p>
--	--	---	---



Let us assume that there is a production line with work stations x, y and z. Also assume that each machine at x, y and z can produce 200 items, 100 items, and 50 items per hour respectively. If each machine were to produce only 50 items per hour then each hour the machines at x and y would be idle for 45 and 30 minutes respectively. Such a layout will be unbalanced one and the production line needs balancing.

As an another example, a bakery would not be in balance, if the oven continuously baked loaves at the rate of 600 per hour and wrapping machine could only wrap 400 loaves per hour Hence the production line requires balancing.

Methods of Line Balancing:

(i) The one possibility in the right direction, as far as balancing the line is concerned, would be to increase the output.

(ii) The second possibility is that another product may be sent close to the first one so that some idle machines may be used jointly.

(iii) The third possibility may be to estimate the output of the last work station. This can be taken as the minimum output of all the intermediate work stations.

A balanced layout eliminates bottleneck operations as well as preventing the unnecessary duplication of equipment capacity. Line balancing is a major consideration in layout because a lack of balance can most easily hinder the production.

For balancing it is not essential that output of each operation should be same but the essential is to see that output of fastest machine should be multiple of the output of the remaining other machines.

1

b

l

1. Roller conveyors may be gravity aided or powered and are employed for transporting products having flat bottoms. Bigger jobs can be handled as they are, whereas small items are put in boxes, tins or pallets before being transferred. Roller conveyors can move the material along straight or curved paths.

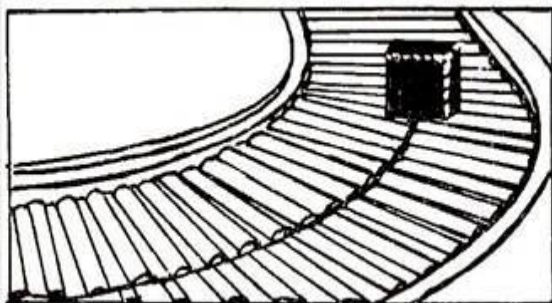

Write Any Two conveyor.Fig-01,explanation-02 for each

2. Belt conveyors are substituted for roller conveyors when the parts are small and are required to be transferred separately, from one station to another.

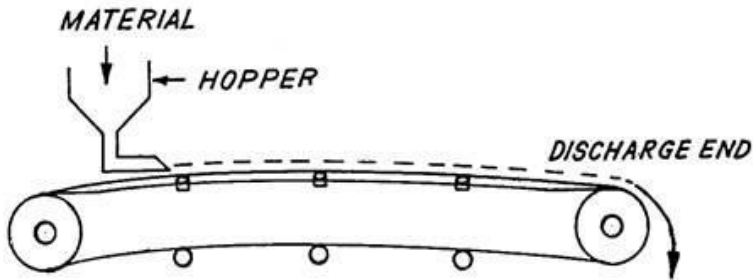

3. A chain conveyor consists of overhead mounted endless chain. It is supported from the ceiling and has a fixed path to travel. It saves valuable floor space. The arrangement is such that the lifting mechanism (may be an electromagnet or a hook) lowers down for loading and unloading of the products.

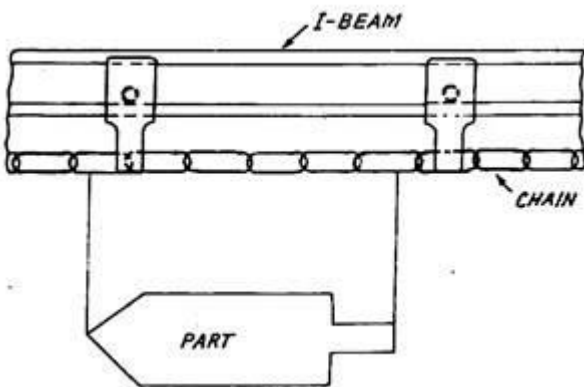

4. Screw Conveyor, Pneumatic Conveyor, Elevated Conveyor .

ii

Production control is one of the most important function of manufacturing firm which plans, directs and controls the material supply and processing activities of an enterprise, so that specified products are produced as per schedule. If there is any actual performance from planned performance ,corrective steps are suggested to improve performance .

So it is the procedure of planning, routing, scheduling, dispatching and expediting the flow of materials, parts, subassemblies, and assemblies within the plant from the raw state to the finished product in a orderly and efficient manner. A control system involves four stages namely observation, analysis, corrective action and post-operation evaluation. Production control system considers these elements in its different functions.

The control of production is necessary to be sure that the production schedules are being met and the job will be delivered as per the predecided plans. It involves an

Explanation-04
benefits-02



		<p>information feedback mechanism and a system of corrective action. Production control follows up the scheduled plans, compares the actual output with the planned one, and points out deviation, if any, so that the same can be corrected through the adjustments of men, materials and machines. In brief ,a production control receives work progress reports, compares them with the scheduled plans, removes causes of delays in production, modifies the schedules or plant capacities and expedites the work.</p> <p>Benefits of Production Control</p> <p style="padding-left: 40px;">Improvements in profits through the reduction in indirect costs, set up costs, reduction in scrap, inventory costs.</p> <p style="padding-left: 40px;">Competitive advantage-reliable delivery to customers, lower production costs and greater pricing flexibility.</p>	
--	--	--	--

Q. No.	Sub Q. N.	Answer	Marking Scheme
2	a.	<p>Types of AGVS</p> <ol style="list-style-type: none"> 1.Towing Vehicles (also called "tugger" vehicles) were the first type introduced and are still a very popular type today. Towing vehicles can pull a multitude of trailer types and have capacities ranging from 2,000 pounds to 160,000 pounds. 2.AGVS Unit Load Vehicles are equipped with decks, which permit unit load transportation and often automatic load transfer. The decks can either be lift and lower type, powered or non-powered roller, chain or belt decks or custom decks with multiple compartments. 3.AGVS Pallet Trucks are designed to transport palletized loads to and from floor level; eliminating the need for fixed load stands. 4.AGVS Fork Truck has the ability to service loads both at floor level and on stands. In some cases these vehicles can also stack loads in rack. They can sometimes lift up to 30' to store or retrieve on high-bay racking. 5.AGVS Hybrid Vehicles are adapted from a standard man-aboard truck so that they can run fully automated or be driven by a fork truck driver. These can be used for trailer loading as well as moving materials around warehouses. Most often, they are equipped with forks, but can be customized to accommodate most load types 6.Light Load AGVS are vehicles which have capacities in the neighborhood of 500 pounds or less and are used to transport small parts, baskets, or other light loads though a light manufacturing environment. They are designed to operate in areas with limited space. 7.AGVS Assembly Line Vehicles are an adaptation of the light load AGVS for applications 	<p>Types-04</p> <p>Functions-02</p> <p>Applications-02</p>



involving serial assembly processes.

Automated Guided Vehicles can be used in a wide variety of applications to transport many different types of material including pallets, rolls, racks, carts, and containers. AGVs excel in applications with the following characteristics:

- Repetitive movement of materials over a distance
- Regular delivery of stable loads
- Medium throughput/volume
- When on-time delivery is critical and late deliveries are causing inefficiency
- Operations with at least two shifts
- Processes where tracking material is important

b

Process Planning is the selection of a systematic method or process by which the product is to be manufactured economically and competitively.

Steps:

- 1) Study of part drawings and its specifications.
- 2) To decide about make or buy about the part under planning.
- 3) Selection of most appropriate process which is competitive and economical.
- 4) Deciding the sequence of operations which comprises the selected process. Operations are combined wherever possible.
- 5) Determination of blank size of raw material and list of material is prepared.
- 6) As per the capacity and capability, the suitable machines with accessories are selected.
- 7) Determination of inspection points or stages on product manufacturing line.
- 8) Selection of labour, tools, measuring and inspection devices.
- 9) Estimation of process and manufacturing cost of product.
- 10) Preparation of route and operation sheet which is also called process sheet.

Def.-01
Steps-07



OPERATION SHEET

Part No. 01

Material : H.S.S

Name : Turning Job

Quantity : 01

Operation No.	Description of operation	Machine	Tools, Gauge
1.	Clamp job in universal chuck 110mm of job projecting from chuck	Lathe	—
2.	Face end dia 54 mm	— " —	Facing tool, Steel rule
3.	Turn dia 24 mm	— " —	Turning tool, vernier caliper.
4.	Turn taper with taper turning attachment to length 20 mm	— " —	Taper gauge
5.	Return tailstock to normal position	— " —	—
6.	Turn dia. 30 mm to length 50 mm	— " —	Turning tool, V.C
7.	Clamp job on other end	— " —	—
8.	Cut off stock	— " —	Cutting tool, V.C
9.	Turn dia 50 mm to length 30 mm	— " —	V.C
10.	Finish face end	— " —	—

Operation sheet including sequence of operations from start to end-08 marks



3 a Factors that affecting on selection of site.

1. Availability of raw material:

As far as possible the site selected should be near the source of raw materials so that cost of transportation can be minimized and storing cost can be reduced especially when the raw material is heavy and bulky or cheap but loses a good amount of weight during processing. For example most of the iron and steel industries are situated in Orissa and Bihar, Paper industries in Ballarpur due to availability of raw material in these areas.

2. Availability of labour: Available of right kind of labour in required numbers of reasonable rates is also deciding factor in site selection. Unskilled labours are amply available at major industrial areas and rural areas but however firms requiring skilled labour be situated near the urban industrial area.

3. Climatic condition: Climatic conditions largely affect certain production processes and also the efficiency of employees. For example textile industries required moist climate due to which these types of industries are situated near Ahmadabad and Mumbai; similarly Tea and Coffee near Assam.

4. Proximity of market: Market is another important factor affecting site selection. Industrial units using raw material should be located near the markets to serve the customer with minimum service cost

5. Transport and communication facilities: While selecting the site, adequate transportation facilities should be considered. The optimum site is the site which is well connected by various modes of transportation.

6. Availability of water: Water is required for drinking and sanitary purpose of all industries. Therefore, clean and adequate water should be available near the site.

7. Availability of power and fuel: All industries require power and fuel to run the prime movers. Therefore, the site selected should have these facilities available at cheaper rate.

8. Legal Aspects: Local bye laws, taxes etc. are also important because they directly reflect in total cost. So while selection, it should also consider legal aspects.

9. Amenities and recreational facilities: Facilities like schools, hospitals, garden, and play grounds should also be needed for employee and their family.

10. Scope of Future expansion: Site selected should be in such a way that a plenty of land other facilities must be available for future expansion.

11. Community attitude: Mindset of the local people is also important, many times they oppose the work.

Any four point – 4 marks.

b Difference between floor and centralized inspection.

Parameters	Floor Inspection	Centralized Inspection
Definition.	Inspection is done at the place where the part is made or assembled is called floor inspection.	The inspection is done at a particular centralized place is called centralized inspection.
Measuring instruments used	Generally small and light weight instruments are used for floor inspection.	Sensitive and delicate instrument can be used for centralized inspection as it is done in lab.
Suitability	Heavy parts are inspected in floor inspection	Light weight parts can be chosen for centralized inspection
Mode of Inspection.	Online inspection is possible	Offline inspection needs to be done.

4 points - 1 mark for each point.

Explain the factor affecting process planning.



	<p>c</p> <p>Factors affecting process planning.</p> <p>a. Size and shape of part: The size and shape of many components decides the basic operations for the manufacturing of part. For example : For manufacturing a shaft, the necessary information is shape of raw material, size of shaft, according to that we select the sequence of operations, machines to be used and material handling activities.</p> <p>b. Strength characteristics of the part: The part strength also decides that which type of process is employed for producing it. Because the different types of load acted on the part during its working such as impact load, tensile load or shock load etc. according to that process planning is done.</p> <p>c. Quantity required: According to the no. of output produced, the process planning is decided. For example: Part which is manufacture in large no. for that general purpose machine is used and for large size and less no. of part special purpose machines are used.</p> <p>d. The accuracy and surface quality required: For achieving accuracy, product should be manufactured such a way that it should give higher dimensional accuracy and high degree of surface finish according to that machines and process is to be selected.</p> <p>e. Utilization of existing equipments: While selecting the process, full capacity of existing machines & its tooling must be utilized, otherwise the existing machinery will remain idle and more capital will be invested on new machines.</p> <p>f. Skill of manpower: Skill of available manpower must be known to determine the need for added operations to avoid defectives due to poor workmanship.</p> <p>g. Delivery date of components or product: Short time period of delivery generally do not allow process engineer to select most economical process and tool for economic production. Due to insufficient time, he may use less efficient machine and tool on hand. On other hand, longer delivery schedule give process engineer sufficient time to go details of each aspect to select most economical process.</p> <p>d</p> <p>Symptoms of bad layout.</p> <p>The symptoms of bad layout are listed below:</p> <ol style="list-style-type: none">1. Poor utilization of space.2. Long material flow lines.3. Congestion for movement of materials and men.4. Large amount work-in-progress.5. Long production cycles.6. More frequent accidents.7. Difficult to supervise and control.8. Spoilage of products during handling.9. Production line bottlenecks. <p>e</p> <p>Method study & its objectives.</p> <p>Definition: Method study may be defined as the systematic investigation (i.e. recording and critical examination) of the existing method of doing a job in order to develop and install an easy, rapid, efficient, effective and less fatigue procedure for doing the same job and at lower costs.</p> <p>Objectives:</p> <ol style="list-style-type: none">1. To improve the working processes.2. To obtain better work place layout, neat & clean environment and working conditions.3. To eliminate the fatigue to operators.4. To achieve better product quality.5. To utilize effectively the men, machine and materials.6. To obtain efficient and fast material handling7. To reduce health hazards.8. To plan the section efficiently.	<p>Any four points with explanation – 4 M.</p> <p>Any 4 points - 1 mark for each point</p> <p>Definition – 2 mark and objectives 2 marks for any 4 points</p>
--	--	---

9. To streamline the procedures.

f

3-2-1 Principle of Location:

It is also known as six pin or six point location principle. In this, the three adjacent locating surfaces of the blank (work piece) are resting against 3, 2 and 1 pins respectively, which prevent 9 degrees of freedom.

This principle states that the six locators are sufficient to restrict the required degree of freedom of any work piece. In this, motion is restricted using clamps and locators. A three pin base can restrict five motions and six pins restrict nine motions.

Methodology of 3-2-1 Principle:

For this, refer the below figure;

[1] The work piece is resting on three pins A, B and C which are inserted in the base of the fixed body.

[2] The work piece cannot rotate about the axes XX and YY and also cannot move downward.

[3] In this way, the five degrees of freedom, 1, 2, 3, 4 and 5 have been arrested.

[4] Two pins D and E are inserted in the fixed body, in a plane perpendicular to the plane containing pins A, B & C.

[5] Now the work piece cannot rotate about the Z axis and also it cannot move towards the left.

[6] Hence the addition of pins D and E restrict three more degrees of freedom, namely 6, 7 and 8.

[7] Another pin F in the second vertical face of the fixed body, arrests

The above method of locating a work piece in a fixture is called the 3-2-1 Principle

04

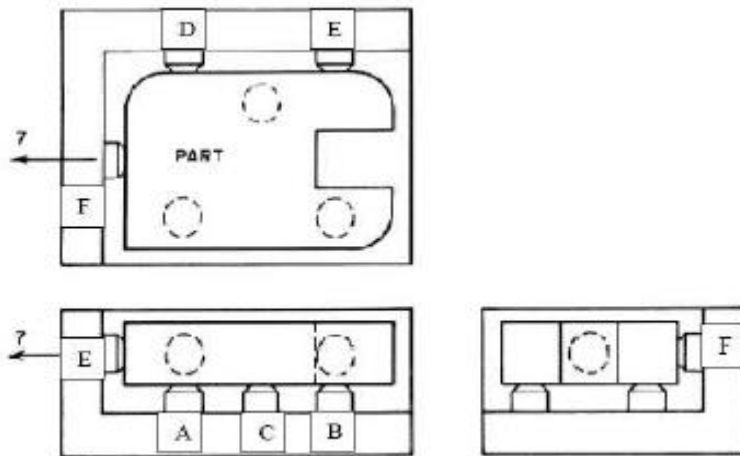



4

a(i)

Difference between jig and fixture.

Sr.No	Parameters	Jigs	Fixtures
1	Definition	A jig may be defined as a device, which holds and locates a work piece as well as guides and controls one or more cutting tools	A fixture is defined as a device used for holding and locating a component or work piece securely in a definite position but it does not guide the cutting tool.
2	Cost	More as compare to fixture as it includes tool guiding and holding arrangement.	Less as compare to jig.
3	Construction	Jigs are lighter in weight for quicker handling	Whereas fixtures are generally heavier in construction
4	Application	It is used in drilling, reaming or tapping operations	It is used for operations like milling, planning, Shaping, turning etc.

Any 4 points,
1 mark for
each point

ii

Meaning of each 'S' in '5S'

Japanese Word	English Equivalent	Meaning
SEIRI	Tidiness	Unrelated materials in workplace
SEITON	Orderliness	Set everything in proper for quick storage and retrieval
SEISO	Cleanliness	Clean the workplace, everything should be janitor
SEIKETSU	Standardization	Standardize the way of manipulating the cleanliness
SHITSUKE	Discipline	Practice 5's daily, make it a way of life this also means a commitment

1 Mark each
for any 4
correct
points



iii

Difference between pneumatic and hydraulic actuator

Sr. No.	Hydraulic Actuator	Pneumatic Actuator
1	They are used to carry heavy loads	They are used to carry lighter loads
2	They are more efficient	They are less efficient
3	Maintenance cost is high	Maintenance cost is low
4	Delivers better performance	Comparatively poor performance
5	They utilize fluid i.e. oil for actuation	They utilize air for actuation
6	Requires more floor space	Require less floor space
7	More Expensive	Less Expensive
8	They are employed where speed requirement is comparatively low	They are employed where fast cycles are required

1 Mark each
for any 4
correct
points

iv

Cycle of Kaizen activity.

Kai means Change and Zen means for the better.

Kaizen is a Japanese term that basically translated to continuous improvement or change to become good is a management concept originated by the Japanese in order to continuously effect incremental changes for the better, involving everybody within the organization from worker to managers. Kaizen is aimed at producing more & more value with less & less waste, attaining better working environment & developing stable process by standardization. The implementation cycle includes Planning of activities to be done. Prepare the action plan for performing those activities after that check the possibilities of performing those and feasibility of the same. Act according to the action plan. This cycle is also called as PDCA cycle.

4 marks to
correct
answer

b

(i)

Outline process chart for replacement of battery in a car.

Task/Job "Replacement battery in a car Charted by: XYZ

Chart begins with: Disconnect the electric supply Charted by: ABC

Chart ends with: Replace with new battery Date: 18/04/2018

Heading of
chart – 1
mark,
Body of
chart
– 3 marks,
Summary of
chart – 2



mark.

- ① Disconnect the electric wiring
 - ② Remove the cover bolts
 - ③ Remove the cover
 - ④ Remove the old battery
 - ⑤ Place the new battery in place
 - ⑥ Check the proper placement
 - ⑦ Fit the cover
 - ⑧ Tight the bolts
- Check the lighting

Summary : O 8

ii

Characteristics of lean manufacturing (any 6)

Lean manufacturing or lean production , often simply " lean ", is a systemic method for the elimination of waste (" Muda") within a manufacturing process. Lean manufacturing is a production practice that considers the expenditure of resources for any goal other than the creation of value for the end customer to be wasteful, and thus a target for elimination. Working from the perspective of the customer who consumes a product or service. It gives values for processes that a customer would be willing to pay for.

Characteristics:

1. Lean manufacturing minimizes production buffer.
2. Rapid machine set ups to permit small production runs by reducing changeover times
3. Use of work teams on the production lines.
4. Extensive training to develop multi skilled workers
5. Job rotation to facilitate on-the-job learning of multiple tasks and skills.
Off-line problem solving or quality circlr groups that involve employees in improvement activities.

Any 6

Points, 1
mark to each
point

5

a

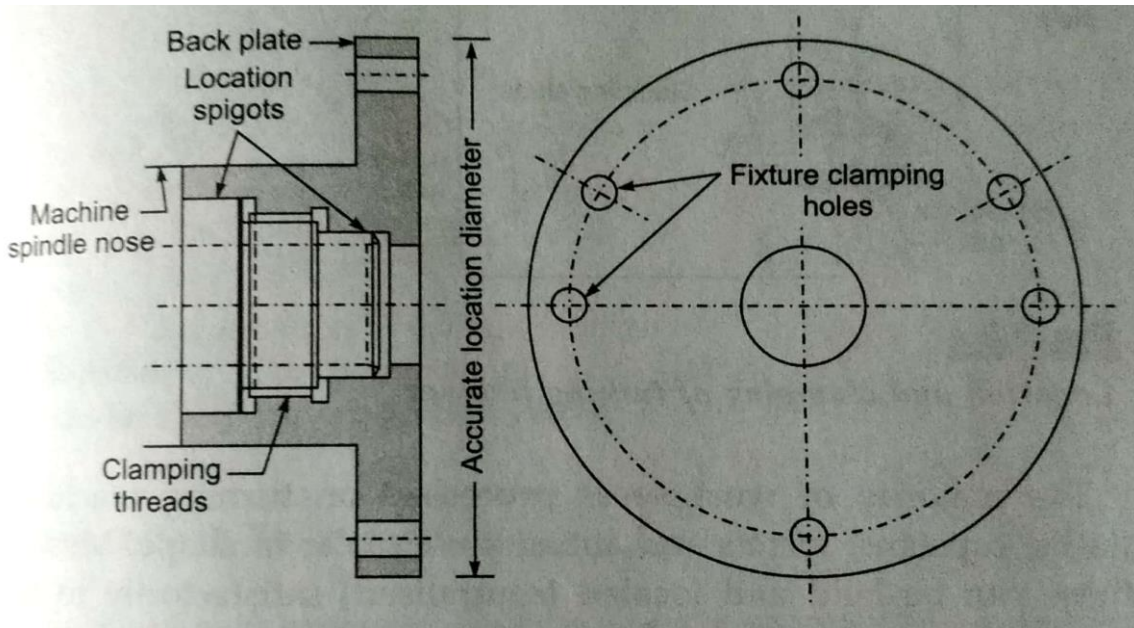

04

Figure: Back plate of Turning Fixture

b

General principle of jig and fixture design.

1. The jig and fixture should be as open as possible to minimize chip or burr accumulation and to enable the operator to remove the chips easily with a brush or an air jet.
2. Fool Proofing
3. Clearance
4. Rigidity
5. Trunions
6. Burr grooves
7. Ejectors
8. Inserts
9. Design for safety
10. Sighting surfaces
11. Simplicity in Design
12. Economical

**(eight points
4 marks)**

c

Time study equipments and its uses.

1. Time Stop watch- When a stop watch is used as a work measurement technique to record times and rates of working for the element of specified job carried out under

specified conditions and for analyzing the data so as to obtain the time necessary to carry a specified job at specified level of performance is referred to as stop watch.

2. Time study Board- It is a printed form with spaces provided for noting down the necessary information about the operation being studied, like name of operation, drawing number, and name of the worker, name of time study person, and the date and place of study.

3. Time study observation sheets- used for holding the observation sheet and stopwatch in position.

4. Pencil, eraser, device like tachometer for checking the speed, etc.

Degree of freedom in robots.

1. It is term used to describe a robots freedom of motion in three dimensional space- specifically, ability to move forward and backward, up and down and left and right.

2. The number of degree of freedom defines the robot's configuration. For example, many simple applications required movement along three axes X, Y and Z.

04

(2 marks
sketch and 2
marks
explanation)

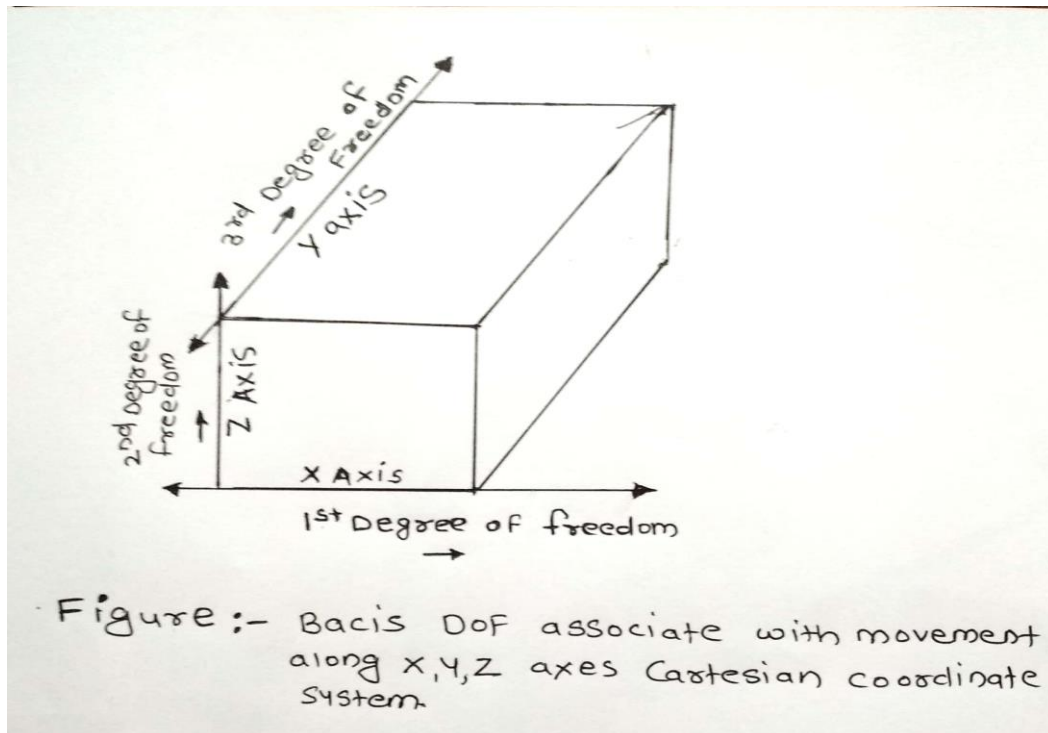



These task required three joints or three degree of freedom. The three degree of freedom in the robot arm are:

1. Rotational Traverse: It is a movement on vertical axis. This is the side to side swivel of the robots arm on its base.
2. Radial Traverse: The radial Traverse is the extension and retraction of the arm, creating in and out motion relative to the base.
3. Vertical Traverse: The vertical traverse provides up and down motion. For the applications that required more freedom, additional degrees can be obtained from the wrist, which gives the end effectors its flexibility. The three degrees of freedom in the wrist have aeronautical names Pitch, Yaw and Roll or Swivel.

Vacuum actuated grippers

Vacuum gripper also called vacuum cups or suction cups which uses vacuum as gripping force. The lifting and holding is done by cups or vacuum surface driven by vacuum system.

1. Usually the cups are available in round or oval shape. The common diameter size of cups is in between 30 mm to 200 mm. the selection of cup and number of cups required depends on :

- a. Weight of the part
- b. Part size and shape.
- c. Nature and type of part etc.

Some time to increase the contact area, multiple cups are used vacuum cups are used to lift flat as well as curved surfaces.

Examples – vacuum cup or suction cup, some vacuum grippers use a closed –cell foam rubber layer for gripping application.

Spherical configuration

Spherical Configuration: - It uses telescopic arm that can be raised or lowered about a horizontal pivot point. The pivot point is mounted on a rotating base and gives the robot its vertical movement. These various joints provide the robot with the ability to move its arm within a spherical envelope.

(2 marks
explanation
and 2 marks
example)

(2 marks
sketch and 2
marks
explanation)

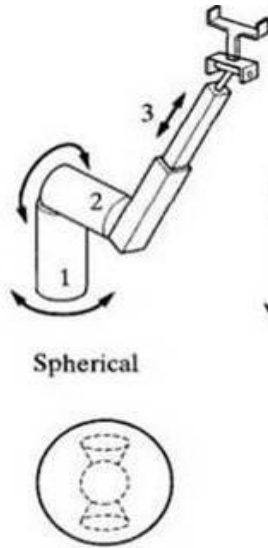

6

a

Gantt chart used in production planning and control.

Gantt Chart is a project planning tool that can be used to represent the timing of tasks required to complete a project. Because Gantt charts are simple to understand and easy to construct, they are used by most project managers for all but the most complex projects.

02

1. The Gantt chart is actually modified bar chart in which horizontal bars are drawn for each activity in proportion to the time required for completing it.

2. It is frequently used to keep track of multiple machine schedules.

3. This chart provides an immediate comparison between schedule and reality (i.e. planned work and actual progress of work.)

4. This is achieved simply by marking the planned work and the actual progress of work on the chart.

5. A cursor attached to Gantt chart can be moved across the chart to compare between the actual progress and planned work till any particular date.

6. A typical Gantt chart is shown in following figure.

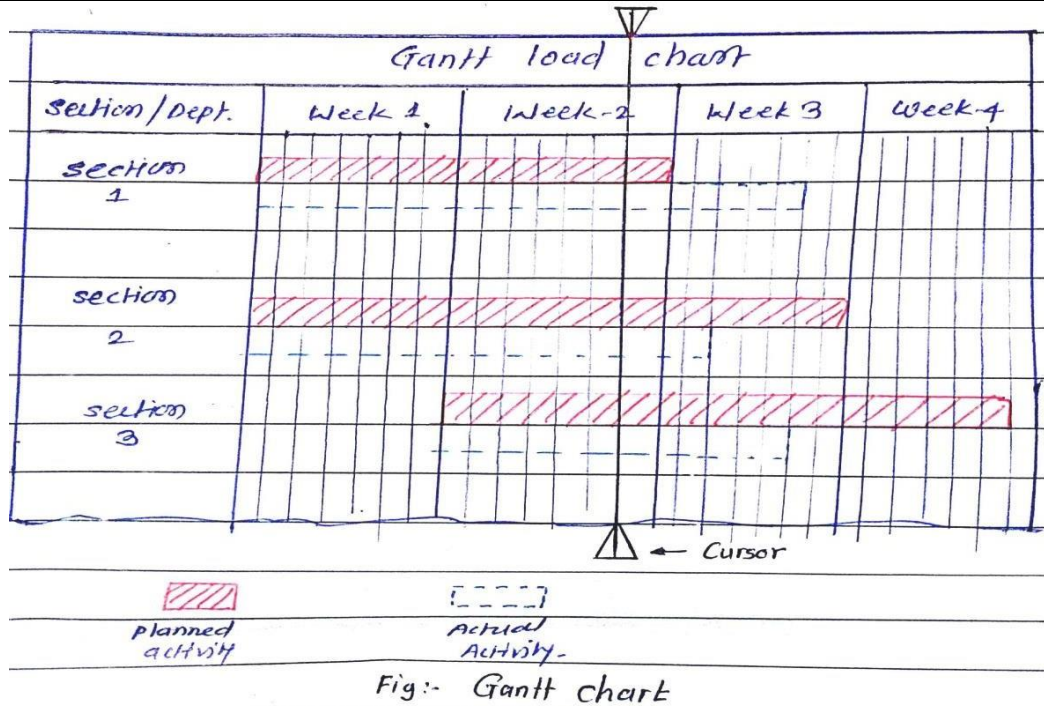

02

Advantages of Gantt chart :

1. It is simple graphical display techniques , suitable for less complex situations.
2. It is extremely easy to understand.
3. There is clarity in communicating important shop information by using Gantt chart
4. It can quickly reveal the current or plan situation to all concerned.

Disadvantages of Gantt chart :

1. The Gantt chart must be updated periodically to account for new jobs.
2. It is used for communicate relatively less information.
3. Required greater time to maintain.
4. Lack of adequate depiction interrelationship between the separate tasks.

02

02



b

Calculation of Standard time for each activity.

Sr. No.	Element	Observed time in minutes	Rating	Basic time (Normal time)
1	a	1	125%	$1 \times (125/100) = 1.25 \text{ min}$
2	b	1.5	120%	$1.5 \times (120/100) = 1.8 \text{ min}$
3	c	2	110%	$2 \times (110/100) = 2.2 \text{ min}$

Total Normal time = $1.25 + 1.8 + 2.2 = 5.25 \text{ min}$

Allowances = % Allowance X Normal Time

For a = $(20/100 \times 1.25) = 0.25 \text{ min}$

b = $(15/100 \times 1.8) = 0.27 \text{ min}$

c = $(20/100 \times 2.2) = 0.44 \text{ min}$

Standard time = Normal time + Allowances

For a = $1.25 + 0.25 = 1.5 \text{ min}$

b = $1.8 + 0.27 = 2.07 \text{ min}$

c = $2.2 + 0.44 = 2.64 \text{ min}$

**(3 marks
Normal time
calculation)**

**(2 marks
Allowances
calculation)**

**(3 marks
Standard
time
calculation)**

c

Joint used in Robotic arm and wrist.

- [1] Rotational joint
- [2] Linear joint
- [3] Twisting joint
- [4] Orthogonal &
- [5] Revolving joint

Rotational Joint: Rotational joint can also be represented as R – Joint. This type will allow the joints to move in a rotary motion along the axis, which is vertical to the arm axes.

Linear Joint: Linear joint can be indicated by the letter L – Joint. This type of joints can perform both translational and sliding movements. These motions will be attained by several ways such as telescoping mechanism and piston. The two links should be in parallel axes for achieving the linear movement.

Twisting Joint: Twisting joint will be referred as V – Joint. This joint makes twisting motion among the output and input link. During this process, the output link axis will be vertical to the rotational axis. The output link rotates in relation to the input link.

Orthogonal Joint: The O – joint is a symbol that is denoted for the orthogonal joint. This joint is somewhat similar to the linear joint. The only difference is that the output and input links will be moving at the right angles.

Revolving Joint: Revolving joint is generally known as V – Joint. Here, the output link axis is perpendicular to the rotational axis, and the input link is parallel to the rotational axes. As like twisting joint, the output link spins about the input link.

04

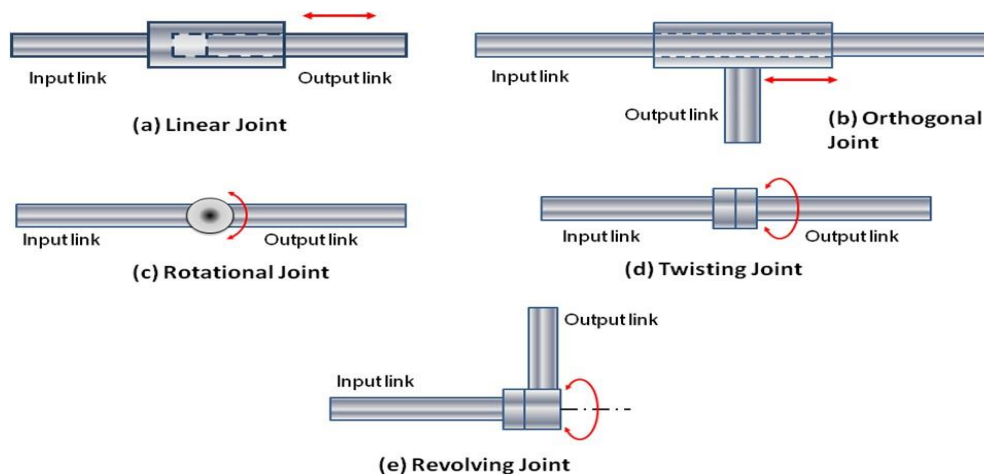

04