



WINTER- 18 EXAMINATION

Subject Name: Electric circuits and network

Model Answer Subject Code:

22330

1

**Important Instructions to examiners:**

- 1) The answers should be examined by key words and not as word-to-word as given in the model answer scheme.
- 2) The model answer and the answer written by candidate may vary but the examiner may try to assess the understanding level of the candidate.
- 3) The language errors such as grammatical, spelling errors should not be given more importance (Not applicable for subject English and Communication Skills).
- 4) While assessing figures, examiner may give credit for principal components indicated in the figure. The figures drawn by candidate and model answer may vary. The examiner may give credit for any equivalent figure drawn.
- 5) Credits may be given step wise for numerical problems. In some cases, the assumed constant values may vary and there may be some difference in the candidate's answers and model answer.
- 6) In case of some questions credit may be given by judgement on part of examiner of relevant answer based on candidate's understanding.
- 7) For programming language papers, credit may be given to any other program based on equivalent concept.

Q. No.	Sub Q. N.	Answers	Marking Scheme
1	(A)	Attempt any FIVE of the following:	10- Total Marks
	(a)	Define:  (i) Admittance (ii) Conductance	2M
	Ans:	i) Admittance:-  Admittance is defined as the reciprocal of impedance .It is denoted by Y.  It is given by $Y = (1/Z)$  ii) Conductance:  Conductance is the ratio of resistance to the square of impedance .It is denoted by G.  It is given by $G = (R/Z^2)$	1 M  for each definition

WINTER- 18 EXAMINATION

Subject Name: Electric circuits and network

Model Answer Subject Code:

22330

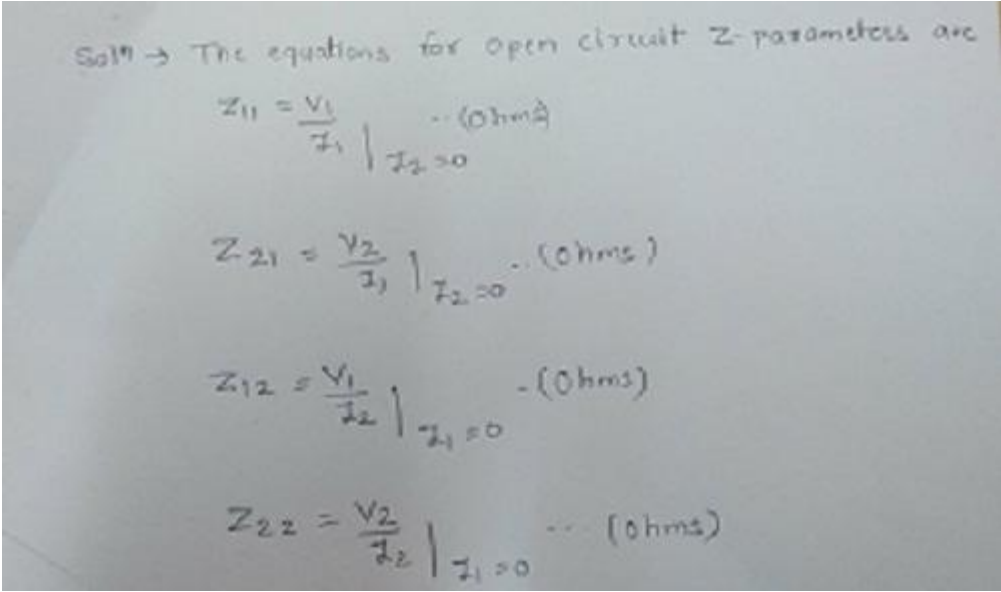
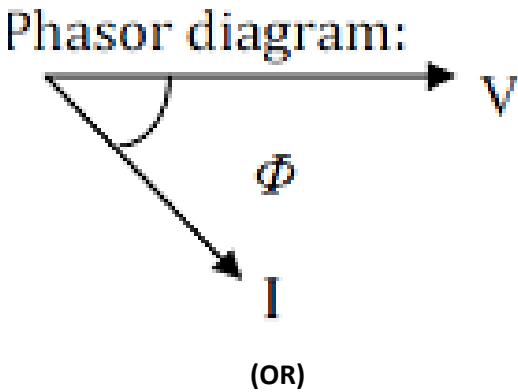
(b)	Write the equation of open circuit Z parameter.	2M
Ans:		½M for each equation
(c)	Draw phasor diagram for R-L series circuit.	2M
Ans:	Phasor diagram for R-L series circuit.	2M
	<p>Phasor diagram:</p>  <p>(OR)</p>	

WINTER- 18 EXAMINATION

Subject Name: Electric circuits and network

Model Answer Subject Code:

22330

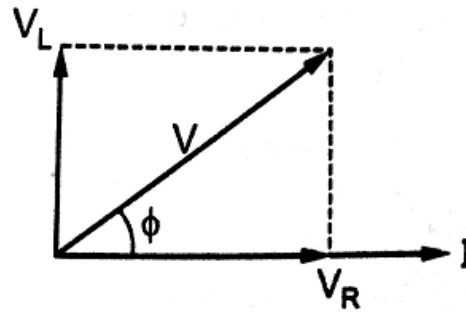

(d) Draw resonance curve for series resonance.

2M

Ans:

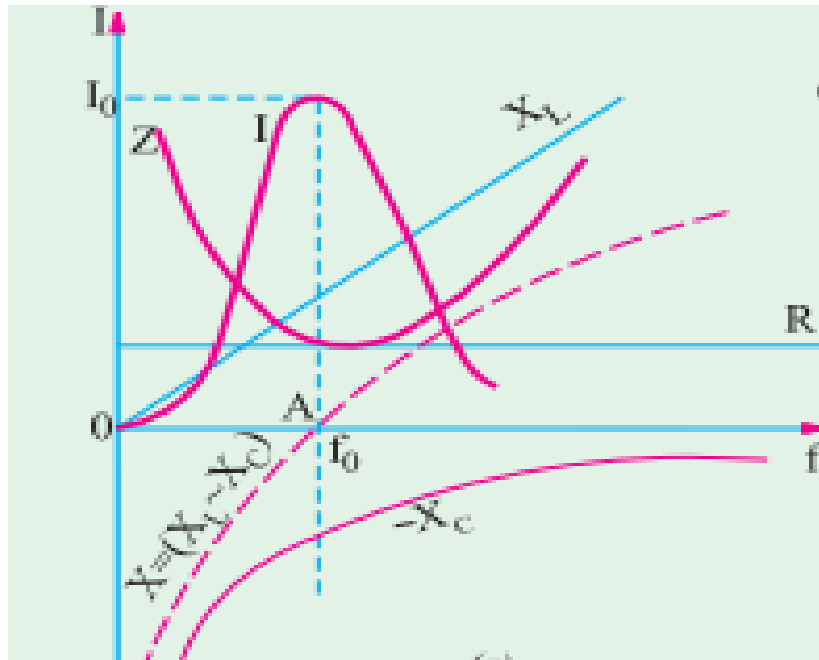

2M

e) Define:

2M

- (i) Node
- (ii) Branch

- Ans:
- i) **Node** : Node is a junction or common point in a network where two or more branches meet.
  - ii) **Branch** : A branch is defined as that part of a network which lies between two junctions.

1 M for  
each  
definitio  
n

WINTER- 18 EXAMINATION

Subject Name: Electric circuits and network

Model Answer Subject Code:

22330

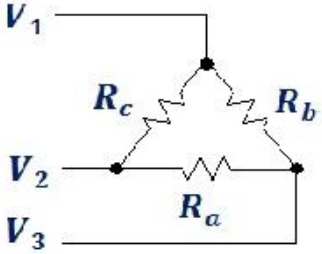
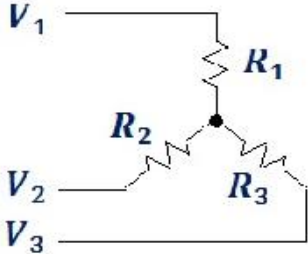
f)	State Thevenins theorem.	2M
Ans:	Any network containing active and/or passive elements and one or more dependent and/or independent voltage/or current sources can be replaced by an equivalent network containing a voltage source (Thevenin's equivalent voltage $V_{TH}$ or $V_{OC}$ ) and a series resistance (called Thevenin's equivalent resistance $R_{TH}$ ), where $V_{OC}$ or $V_{Th}$ is the voltage measured across specified open terminals and $R_{Th}$ is the resistance measured across the same terminals when all the sources present in the network are replaced by their internal resistances.	2M
g)	Write the formula for Delta to Star conversion giving examples.	2M
Ans:	<p>The formula for Delta to Star conversion-</p> <div style="display: flex; justify-content: space-around; align-items: center;">   </div> $R_1 = \frac{R_b R_c}{R_a + R_b + R_c}$ $R_2 = \frac{R_a R_c}{R_a + R_b + R_c}$ $R_3 = \frac{R_a R_b}{R_a + R_b + R_c}$	2M

Q. No.	Sub Q. N.	Answers	Marking Scheme
2		Attempt any THREE of the following:	12- Total Marks

WINTER- 18 EXAMINATION

Subject Name: Electric circuits and network

Model Answer Subject Code:

22330

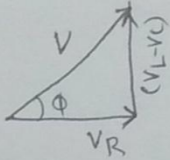
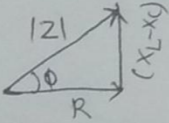
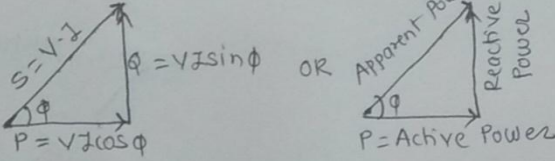
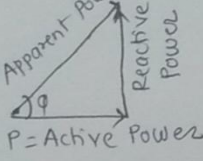
a)	For RLC series circuit draw voltage triangle, power triangle and impedance triangle along with proper labellings and equations for condition $V_L > V_C$ .	4M
Ans:	<p>Sol<sup>n</sup> → For R-L-C series circuit (For cond<sup>n</sup> <math>V_L &gt; V_C</math>)</p> <p>i) Voltage Triangle is given by</p>  <p>ii) Impedance Triangle for <math>V_L &gt; V_C</math> is given by</p>  <p>iii) Power Triangle for <math>V_L &gt; V_C</math> is given by</p>  <p>OR</p>  <p>iv) The v<sub>t</sub> and current equations for <math>V_L &gt; V_C</math></p> $v(t) = V_m \sin \omega t$ $i(t) = I_m \sin(\omega t - \phi)$	<p>Voltage triangle- 1 M</p> <p>Impedance triangle- 1M</p> <p>Power triangle -1 M</p> <p>Voltage equation-1/2M</p> <p>Current equation-1/2 M</p>
b)	Define and state equations for (i) Active Power (ii) Reactive Power (iii) Apparent Power.	4M
Ans:	<p>i) Active Power (P):</p> <p>The active power is defined as the average power <math>P_{avg}</math> taken by or consumed by the given</p>	<p>Active power: 1.5 M</p>



WINTER- 18 EXAMINATION

Subject Name: Electric circuits and network

Model Answer Subject Code:

22330

6

	<p>circuit.</p> <p style="text-align: center;"><b>(OR)</b></p> <p>It is the power which is actually dissipated in the circuit resistance.</p> <p style="text-align: center;"><math>P = V.I.\cos\phi = I^2R</math></p> <p style="text-align: center;"><b>Unit:</b> - Watt <b>OR</b> Kilowatt</p> <p><b>ii) Reactive Power (Q):-</b></p> <p>It is the power developed in the reactive elements present in the circuit.</p> <p style="text-align: center;"><b>(OR)</b></p> <p>The reactive power is defined as the product of V, I and sine of angle between V and I .</p> <p style="text-align: center;"><math>Q = V.I. \sin\phi</math></p> <p style="text-align: center;"><b>Units:</b> - VAR <b>OR</b> KVAR</p> <p><b>iii) Apparent Power (S):-</b></p> <p>It is the product of rms values of applied voltage and current.</p> <p><b>Unit:</b> volt-ampere (VA) <b>OR</b> kilo-volt-ampere (kVA) <b>OR</b> Mega-volt-ampere (MVA)</p> <p><math>S = VI = I^2Z</math> VA</p>	<p><b>Reactive power</b></p> <p><b>1.5 M</b></p> <p><b>Apparent power:</b></p> <p><b>1 M</b></p>
c)	<p><b>Explain the steps for converting practical voltage source into practical current source.</b></p>	<p><b>4M</b></p>
Ans:		

WINTER- 18 EXAMINATION

Subject Name: Electric circuits and network

Model Answer Subject Code:

22330

7

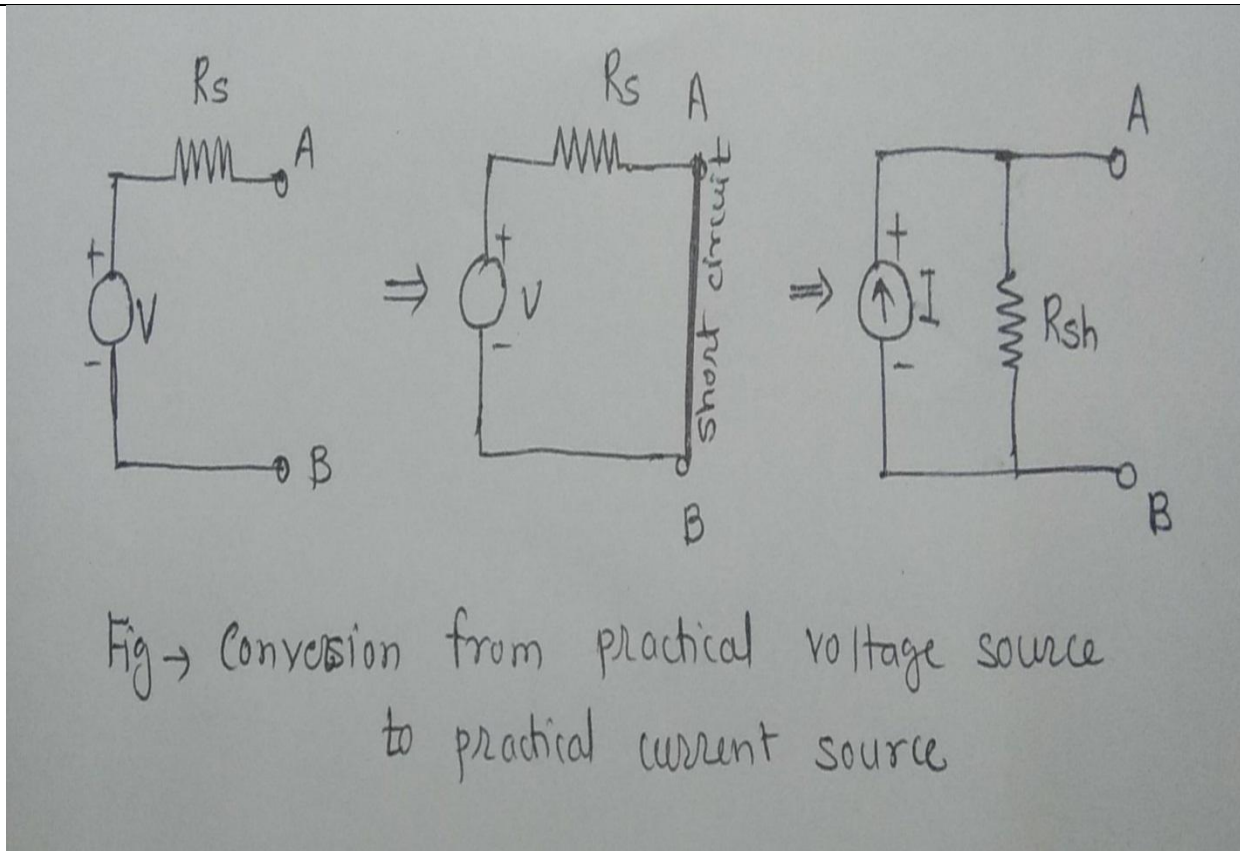

Diagram  
:2 M

A given voltage source with a series resistance can be converted into an equivalent current source with a parallel resistance.

The steps for converting practical voltage source into practical current source are :

i) Terminals A and B of the given voltage source is short circuited as shown. Current supplied by the source is given by

Current  $I = V/R$ .

ii) The value of resistance which is connected in parallel with the equivalent current source will have the same value as that of series resistance. That is  $R_s = R_{sh}$ .

ii) The equivalent current source is connected in parallel with the shunt (parallel) resistance.

Steps  
2 M

WINTER- 18 EXAMINATION

Subject Name: Electric circuits and network

Model Answer Subject Code:

22330

d) Three resistances  $32 \Omega$ ,  $40 \Omega$ ,  $48 \Omega$  are connected in star circuit. Determine its equivalent delta circuit. **4M**

Ans:

$$R = R_1 R_2 + R_2 R_3 + R_3 R_1$$

$$= (32 \times 40) + (40 \times 48) + (48 \times 32)$$

$$\therefore R = 4736 \Omega$$

Now,

$$R_{12} = \frac{R}{R_3} = \frac{4736}{48} = 98.66 \Omega$$

$$R_{23} = \frac{R}{R_1} = \frac{4736}{32} = 148 \Omega$$

$$R_{31} = \frac{R}{R_2} = \frac{4736}{40} = 118.4 \Omega$$

Q. No.	Sub Q. N.	Answers	Marking Scheme
3		Attempt any THREE of the following :	12- Total Marks



WINTER- 18 EXAMINATION

Subject Name: Electric circuits and network

Model Answer Subject Code:

22330

9

a)	If $Z_1 = 3 + j7$ and $Z_2 = 12 - j16$ are connected in parallel. Find the equivalent impedance of combination.	4M
Ans:	<p>Equivalent impedance, <math>Z_{eq} = \frac{Z_1 Z_2}{Z_1 + Z_2} = \frac{(3+j7)(12-j16)}{(3+j7)+(12-j16)} = \frac{(7.62 \angle 66.8)(20 \angle -53.13)}{(7.62 \angle 66.8) + (20 \angle -53.13)}</math></p> $= \frac{152.4 \angle 13.67}{17.5 \angle -40} = 8.71 \angle 53.67 = 5.16 + j7 \Omega$	<p>Formula 1M Steps 1M Ans. 2M</p>
b)	Determine Bandwidth and Quality factor (Q) for the series circuit.	4M
Ans:	<p><b>Band width:</b></p> <p>The bandwidth of a series circuit is given by the band of frequencies which lies between two points on either side of <math>f_0</math> where current falls to <math>I_0 / \sqrt{2}</math>. (graph may be desirable)</p> <div data-bbox="558 1121 1088 1612" data-label="Figure"> </div> <p>From the given fig., band width AB is,</p> $AB = \Delta f = f_2 - f_1 \text{ or } AB = \Delta \omega = \omega_2 - \omega_1 \text{ where } f_1 \text{ and } f_2 \text{ are the corner or edge frequencies.}$	<p>2 M each</p>



WINTER- 18 EXAMINATION

Subject Name: Electric circuits and network

Model Answer Subject Code:

22330

10

(OR)

$$\Delta f = f_r / Q_r = \frac{\frac{1}{2\pi\sqrt{LC}}}{\frac{1\sqrt{L}}{R\sqrt{C}}} = \frac{R}{2\pi L}$$

Quality factor:

Note: any one of the following can be considered

Reciprocal of power factor is called quality ( $Q$ ) factor or its figure of merit. The  $Q$ -factor of a series circuit can be defined as the ratio of impedance to resistance.

$$Q = \frac{Z}{R}$$

It is also defined as,

$$Q = 2\pi \frac{\text{maximum energy stored per cycle}}{\text{Energy dissipated per cycle}}$$

For a resonant circuit it may be determined in any of the following ways

i) It is given by the voltage magnification produced in the circuit at resonance.

$$\begin{aligned} \text{Voltage magnification} &= \frac{V_{L_0}}{V} = \frac{I_0 X_{L_0}}{I_0 R} = \frac{\text{reactive power}}{\text{active power}} = \frac{X_{L_0}}{R} = \frac{\omega_0 L}{R} = \frac{\text{reactance}}{\text{resistance}} \\ \text{or} &= \frac{V_{C_0}}{V} = \frac{I_0 X_{C_0}}{I_0 R} = \frac{\text{reactive power}}{\text{active power}} = \frac{X_{C_0}}{R} = \frac{\text{reactance}}{\text{resistance}} = \frac{1}{\omega_0 CR} \\ \therefore Q\text{-factor, } Q_0 &= \frac{\omega_0 L}{R} = \frac{2\pi f_0 L}{R} = \tan \phi \end{aligned}$$

ii)



WINTER- 18 EXAMINATION

Subject Name: Electric circuits and network

Model Answer Subject Code:

22330

11

$$Q\text{-factor} = 2\pi \frac{\text{maximum stored energy}}{\text{energy dissipated per cycle}} \quad \dots \text{in the circuit}$$

$$= 2\pi \frac{\frac{1}{2} LI_0^2}{I^2 R T_0} = 2\pi \frac{\frac{1}{2} L(\sqrt{2}I)^2}{I^2 R (1/f_0)} = \frac{I^2 2\pi f_0 L}{I^2 R} = \frac{\omega_0 L}{R} = \frac{1}{\omega_0 CR} \quad \dots (T_0 = 1/f_0)$$

iii)

resonant frequency,  $f_0 = \frac{1}{2\pi\sqrt{LC}}$  or  $2\pi f_0 = \frac{1}{\sqrt{LC}}$

Substituting the above in equation,  $Q_0 = \frac{2\pi f_0 L}{R}$ , we get,

$$Q_0 = \frac{1}{R} \sqrt{\frac{L}{C}}$$

iv)  $Q$ -factor of a resonant series circuit may be written as,

$$Q_0 = \frac{\omega_0}{\text{bandwidth}} = \frac{\omega_0}{\Delta\omega} = \frac{\omega_0}{R/L} = \frac{\omega_0 L}{R} = \frac{L}{R\sqrt{LC}} = \frac{1}{R} \sqrt{\frac{L}{C}}$$

v) It may also be deduced as,

$$Q_0 = \frac{\omega_0 L}{R} = \frac{1}{\omega_0 C R} = \frac{1}{R} \sqrt{\frac{L}{C}} = \sqrt{\frac{X_{L0} X_{C0}}{R}} = \frac{f_0}{B_{hp}} = \frac{\omega_0}{\omega_2 - \omega_1} = \frac{f_0}{f_2 - f_1}$$

Where  $B_{hp}$  = bandwidth of the circuit



WINTER- 18 EXAMINATION

Subject Name: Electric circuits and network

Model Answer Subject Code:

22330

12

c) Using Mesh Analysis find current through  $4\ \Omega$  resistance.(Refer fig. 1)

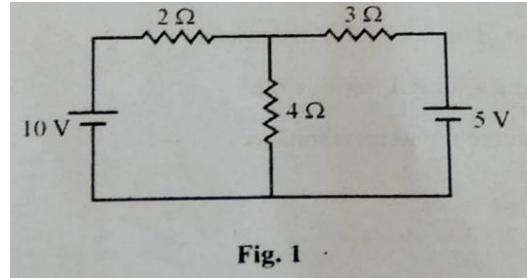

Fig. 1

4M

WINTER- 18 EXAMINATION

Subject Name: Electric circuits and network

Model Answer Subject Code:

22330

13

Ans:

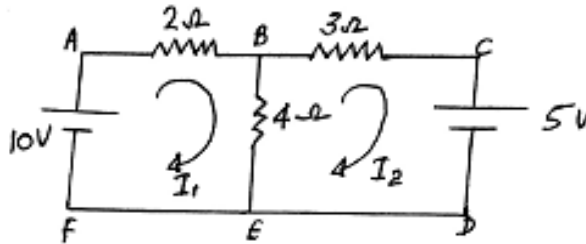

① Apply KVL to loop ABEFA,

$$-2I_1 - 4(I_1 - I_2) + 10 = 0$$

$$-2I_1 - 4I_1 + 4I_2 = -10$$

$$-6I_1 + 4I_2 = -10 \quad \text{--- ①}$$

② Apply KVL to loop BCDEB,

$$-3I_2 - 5 - 4(I_2 - I_1) = 0$$

$$-3I_2 - 5 - 4I_2 + 4I_1 = 0$$

$$4I_1 - 7I_2 = 5 \quad \text{--- ②}$$

Solving eqn ① & ② we get,

$$I_1 = 1.92 \text{ A}, \quad I_2 = 0.38 \text{ A}$$

∴ Current through  $4\Omega$ ,  $I_1 - I_2 = 1.92 - 0.38 = 1.54 \text{ A}$  (downwards)

Correct  
calculati  
on-  
4M(Give  
step  
marking  
)

d) Explain the procedure for solving Thevenin's theorem using suitable example.

4M

Ans: Steps to find Thevenin's equivalent circuit, taking an example is as follows:

1M each

WINTER- 18 EXAMINATION

Subject Name: Electric circuits and network

Model Answer Subject Code:

22330

14

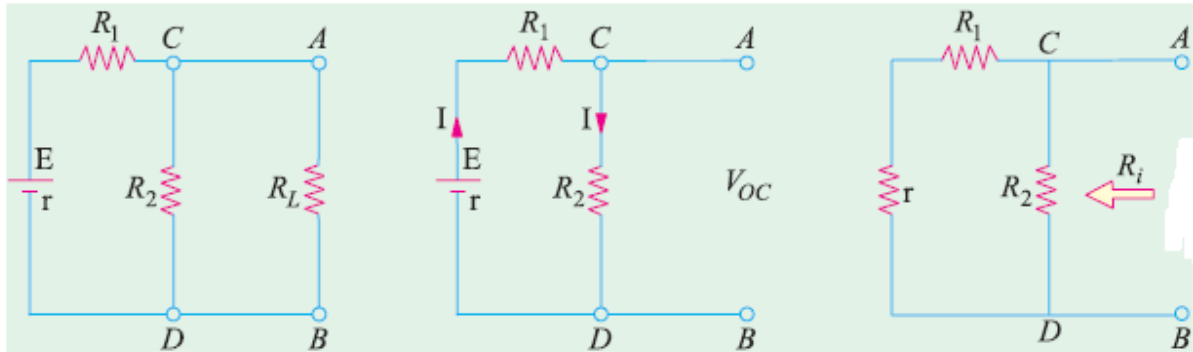

Fig.(a)

fig.(b)

fig.(c)

1. From the given circuit(fig.a), Remove  $R_L$  from the terminals  $A$  and  $B$  and redraw the circuit as shown in Fig.b.

2. Calculate the open-circuit voltage  $V_{oc}$  which appears across terminals  $A$  and  $B$ .

As seen,  $V_{oc} = \text{drop across } R_2 = IR_2$  where  $I$  is the circuit current when  $A$  and  $B$  are open.

$$I = \frac{E}{R_1 + R_2 + r} \quad \therefore V_{oc} = IR_2 = \frac{ER_2}{R_1 + R_2 + r} \quad [r \text{ is the internal resistance of battery}]$$

It is also called 'Thevenin voltage'  $V_{th}$ .

3. Now, imagine the battery to be removed from the circuit, leaving its internal resistance  $r$  behind and redraw the circuit, as shown in Fig.(c). When viewed *inwards* from terminals  $A$  and  $B$ , the equivalent resistance is given as,

$$R = R_2 \parallel (R_1 + r) = \frac{R_2(R_1 + r)}{R_2 + (R_1 + r)}$$

This is called Thevenin's equivalent resistance  $R_{th}$ .

4. Connect  $R_L$  back across terminals  $A$  and  $B$ (fig.d) from where it was temporarily removed earlier.

WINTER- 18 EXAMINATION

Subject Name: Electric circuits and network

Model Answer Subject Code:

22330

15

Current flowing through  $R_L$  is given by

$$I = \frac{V_{th}}{R_{th} + R_L}$$

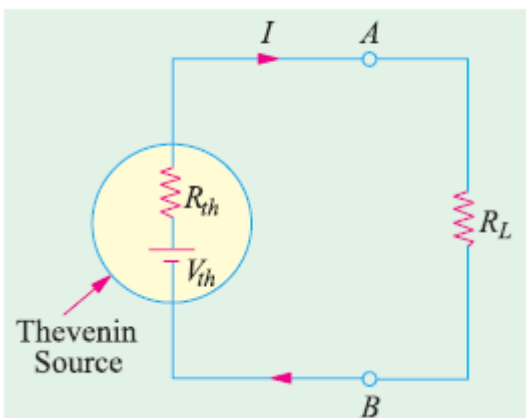

Fig.(d)

Q. No.	Sub Q. N.	Answers	Marking Scheme
4		Attempt any THREE of the following :	12- Total Marks
	(a)	A coil has resistance of $4 \Omega$ and an inductance of 9.55 mH. Calculate (i) Reactance (ii) The impedance (iii) The current taken from 240 V, 50 Hz supply.	4M

WINTER- 18 EXAMINATION

Subject Name: Electric circuits and network

Model Answer Subject Code:

22330

16

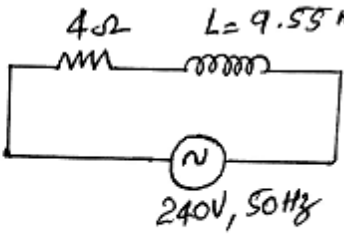
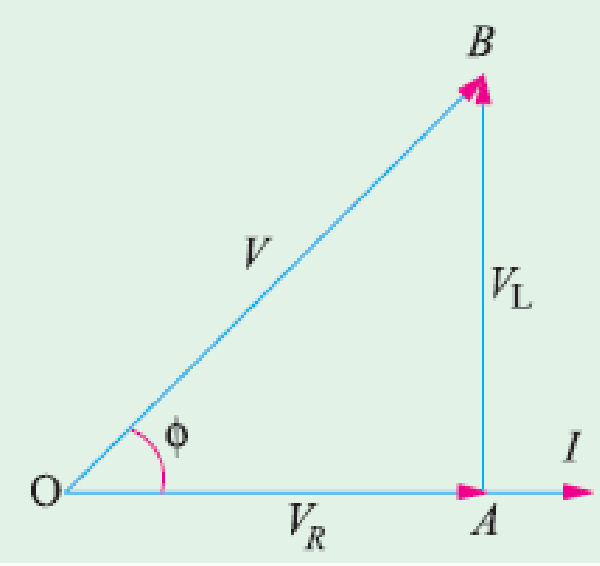
Ans:	 <p>Data given:</p> $R = 4\Omega, L = 9.55 \text{ mH}, V = 240\text{V}, f = 50 \text{ Hz}$ <p>i) Reactance, <math>X_L = 2\pi fL = 2 \times 3.14 \times 50 \times 9.55 \times 10^{-3} = 3\Omega</math></p> <p>ii) Impedance, <math>Z = R + jX_L = 4 + j3 = 5 \angle 36.87^\circ \Omega</math></p> <p>iii) Current, <math>I = \frac{V}{Z} = \frac{240}{5} = \underline{\underline{48 \text{ A}}}</math></p> <p>(or)</p> <p>ii) Impedance, <math>Z = \sqrt{R^2 + X_L^2} = \sqrt{4^2 + 3^2} = \underline{\underline{5 \Omega}}</math></p>	<p>1M each for paramet ers &amp; 1M for proper steps followed</p>
(b)	<p>Draw the phasor diagrams for a series RL and series RC with AC supply.</p>	<p>4M</p>
Ans:	<p>Phasor diagram of RL series circuit:</p> 	<p>2M for each diagram</p>



WINTER- 18 EXAMINATION

Subject Name: Electric circuits and network

Model Answer Subject Code:

22330

17

Phasor diagram of RC series circuit:

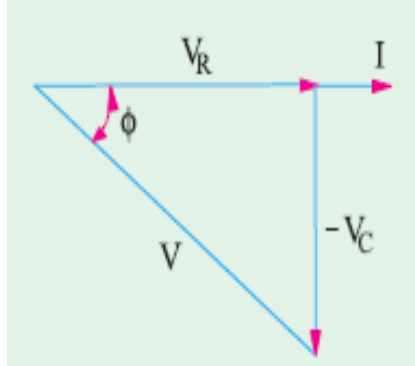

(c) Compare series and parallel circuits.

4M

Ans:

1M each  
for any 4  
points

Sr.No.	Series circuit	Parallel circuit
1	<p>Element are connected end-on-end</p>	<p>Equi-potential ends are connected together</p>
2	<p>Same current flows through all parts of the circuit.</p>	<p>Same voltage acts across all parts of the circuit</p>
3	<p>Different resistors have their individual voltage drops.</p>	<p>Different resistors have their individual currents.</p>
4	<p>Voltage drops are additive.</p>	<p>Branch currents are additive.</p>



WINTER- 18 EXAMINATION

Subject Name: Electric circuits and network

Model Answer Subject Code:

22330

18

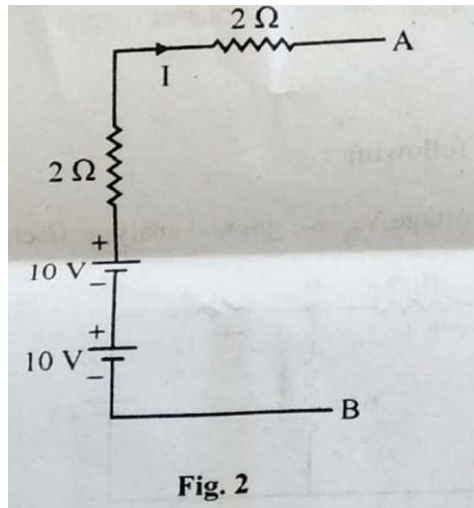
	5	Applied voltage equals the sum of different voltage drops.	Individual voltages is equal to supply voltage	
	6	Resistances are additive.	Conductances are additive.	
	7	Powers are additive.	Powers are additive	
(d)	<p>Using source transformation technique find the resultant current (I) through circuit. (Refer fig. 2)</p>  <p style="text-align: center;">Fig. 2</p>			4M

Ans:

Adding both the sources the circuit becomes,

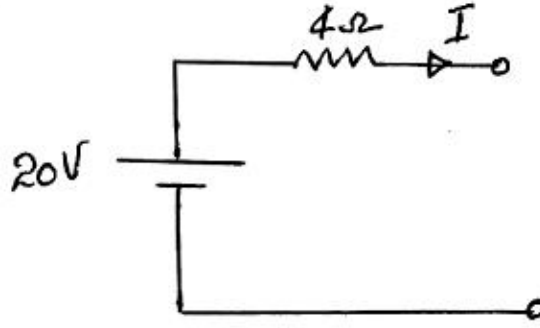

Its equivalent current source is

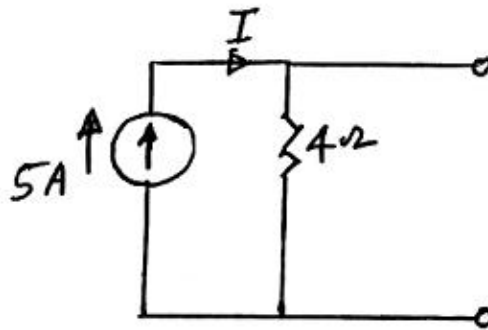

$$I = 5A$$

Correct  
calculati  
on-4M

(e) Using super-position theorem find current through  $4\ \Omega$  resistance. (Refer fig. 3)

4M

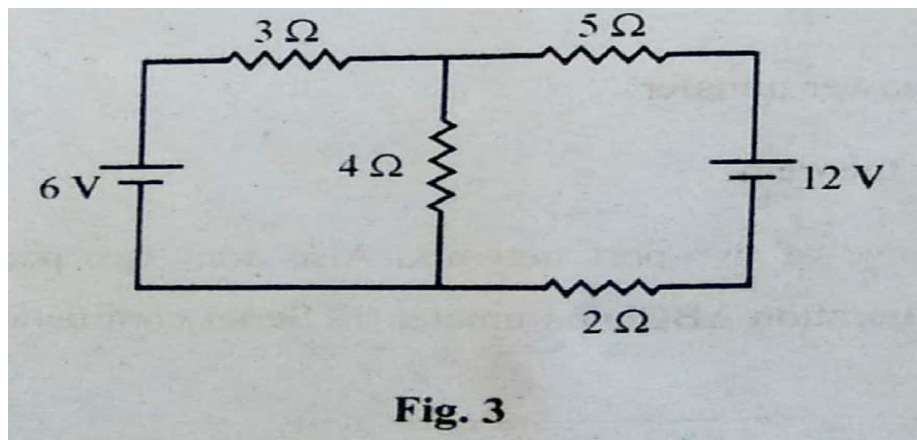

Fig. 3



WINTER- 18 EXAMINATION

Subject Name: Electric circuits and network

Model Answer Subject Code:

22330

20

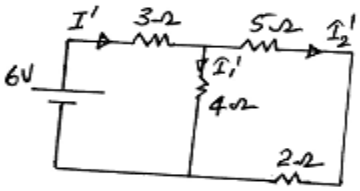
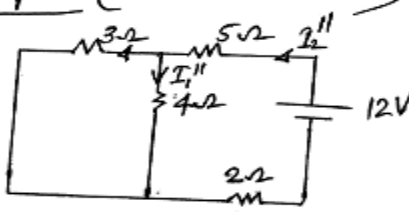
Ans:	<p><u>Step I (With 6V source alone)</u></p>  $I = \frac{V}{R_{eq}} = \frac{6}{3 + 4 \parallel (5+2)}$ $= \frac{6}{3 + 2.55} = 1.08 A$ $I_1 = \frac{I' \times (5+2)}{4+5+2} = \frac{1.08 \times 7}{11} = 0.69 A \downarrow$ <p><u>Step II (With 12V source alone)</u></p>  $I_2'' = \frac{V}{R_{eq}} = \frac{12}{5 + (3 \parallel 4) + 2}$ $= \frac{12}{8.71} = 1.38 A$ $I_1'' = \frac{I_2'' \times 3}{3+4} = \frac{1.38 \times 3}{7} = 0.59 A \downarrow$ <p>∴ Current through 4Ω = <math>I_1' + I_1'' = 0.69 + 0.59 = 1.28 A \downarrow</math></p>	Corrct calculati on -4M
------	---	-------------------------------

Q. No.	Sub Q. N.	Answers	Marking Scheme
5.		Attempt any TWO of the following:	12- Total Marks
	a)	Derive the expression for resonance frequency for parallel circuit.	6M
	Ans:	A parallel circuit containing an inductance and a capacitance is said to be in resonance when the current through the parallel combination is in phase with the supply voltage.  Consider a parallel combination of L and C as shown below.	Diagram 2M,  derivati on 4M

WINTER- 18 EXAMINATION

Subject Name: Electric circuits and network

Model Answer Subject Code:

22330

21

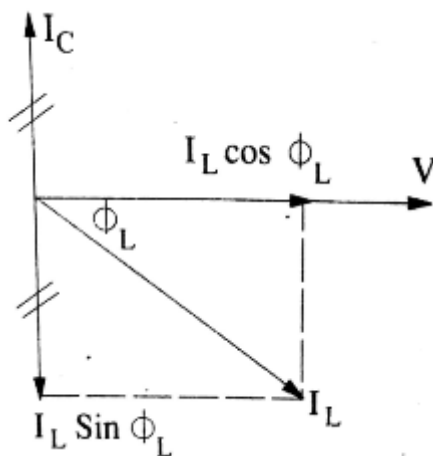
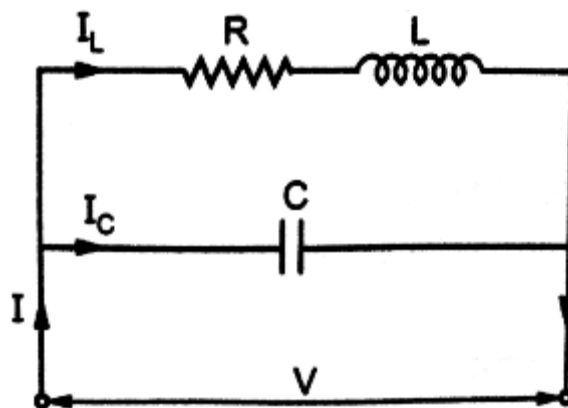

The vector diagram for this circuit is as shown.

The net reactive component of current =  $I_C - I_L \sin \phi_L$ .

At resonance ,its value is zero.

That is  $I_C - I_L \sin \phi_L = 0$  or  $I_C = I_L \sin \phi_L$



WINTER- 18 EXAMINATION

Subject Name: Electric circuits and network

Model Answer Subject Code:

22330

22

From the diagram above,  $I_L = V/Z$ ,

$$\sin\phi_L = X_L/Z, I_C = V/X_C$$

Substituting these values in the above equation, the condition for resonance becomes

$$V/X_C = (V/Z)(X_L/Z) \text{ or } (X_L)(X_C) = Z^2$$

Substituting  $X_L = \omega L$  and  $X_C = 1/\omega C$

$$(\omega L / \omega C) = Z^2$$

$$L/C = R^2 + (2\pi fL)^2$$

$$(2\pi fL)^2 = \frac{L}{C} - \frac{R^2}{L^2}$$

$$2\pi f = \sqrt{\frac{1}{LC} - \frac{R^2}{L^2}}$$

If  $f = f_r$  = resonant frequency, then,

$$f_r = \frac{1}{2\pi} \sqrt{\frac{1}{LC} - \frac{R^2}{L^2}}$$

If R is negligible, then

$$f_r = \frac{1}{2\pi\sqrt{LC}}$$

b) Calculate current through 8 Ω resistance using Norton's theorem. (Refer fig. 4)

6M

WINTER- 18 EXAMINATION

Subject Name: Electric circuits and network

Model Answer Subject Code:

22330

23

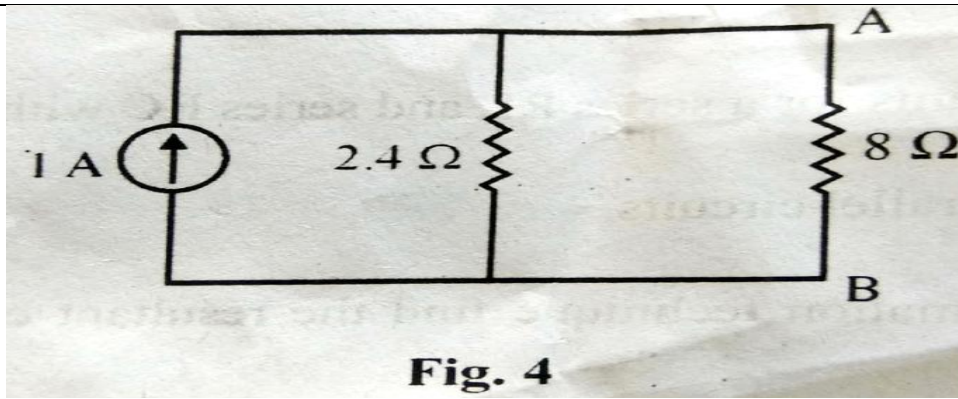

Ans:

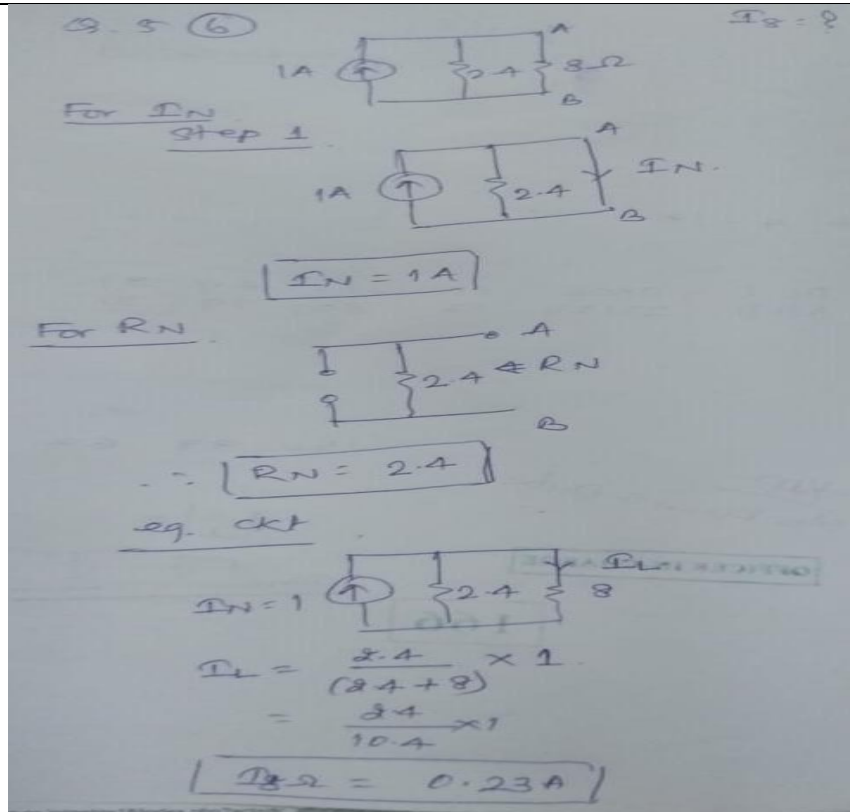

To find  
 $I_N$  1M  
 $R_N$  2M  
Equivalent  
circuit 1M  
 $I_L$  1M  
 $I_8$  1M

c) Explain 'Π' and 'T' circuit with proper phasor diagram.

6M

Ans: Note : As phasor diagram of 'Π' and 'T' circuit is not specified in syllabus, marks may be awarded for any relevant diagram and explanation of T and π network.

Diagram  
2M each  
Explanation: 1M  
each

WINTER- 18 EXAMINATION

Subject Name: Electric circuits and network

Model Answer Subject Code:

22330

24

T networks are used to represent the equivalent of transmission line theory, filters, etc.

Ladder network in transmission lines is constructed using T network in series. If Z parameters and ABCD parameters of a network are known, then T network can be constructed.

**T network**

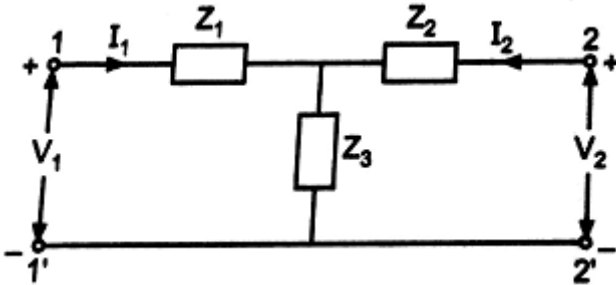

**$\pi$  network**

This is also an important network frequently used in transmission line theory. If Y parameters of a network are known, then  $\pi$  network can be constructed.

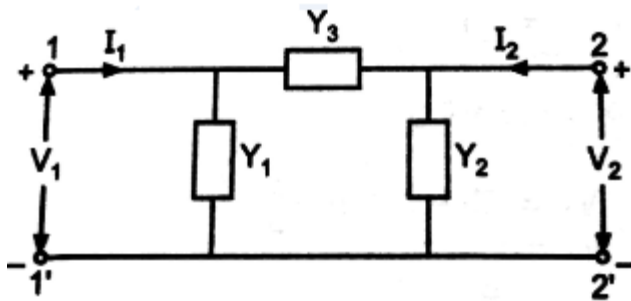

Q. No.	Sub Q. N.	Answers	Marking Scheme
6.		Attempt any TWO of the following :	12- Total Marks



WINTER- 18 EXAMINATION

Subject Name: Electric circuits and network

Model Answer Subject Code:

22330

25

a) Calculate the nodal voltage  $V_B$  using nodal analysis. (Refer fig. 5)

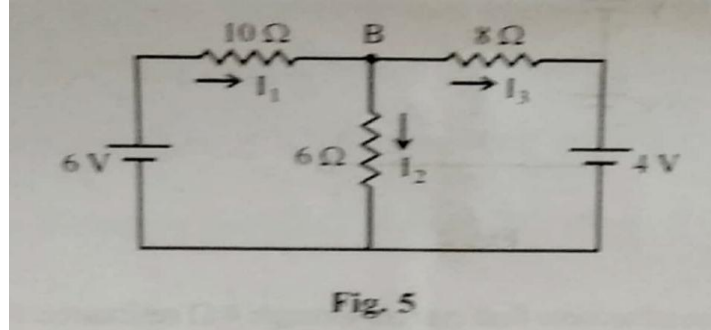

6M

Ans:

Q. 6  
②

KCL at 'B'

$$I_1 = I_2 + I_3$$

$$\frac{6 - V_B}{10} = \frac{V_B}{6} + \frac{V_B - 4}{8}$$

$$\frac{6 - V_B}{5} = \frac{4V_B + 3V_B - 12}{12}$$

$$\frac{6 - V_B}{5} = \frac{7V_B - 12}{12}$$

$$72 - 12V_B = 35V_B - 60$$

$$72 + 60 = 35V_B + 12V_B$$

$$132 = 47V_B$$

$$\therefore V_B = \frac{132}{47}$$

$V_B = 2.80V$

Correct  
calculati  
on-6M

b) State and explain:

- (i) Maximum power transfer
- (ii) Reciprocity theorem

6M

Ans: Maximum Power Transfer Theorem:

Maximum Power Transfer Theorem states that "Maximum power is transferred from the

Stateme  
nt 1M

WINTER- 18 EXAMINATION

Subject Name: Electric circuits and network

Model Answer Subject Code:

22330

26

source to the load when the load resistance is equal to the Thevenin's equivalent resistance of the given circuit as seen from load terminals"

i.e,  $R_L = R_{TH}$

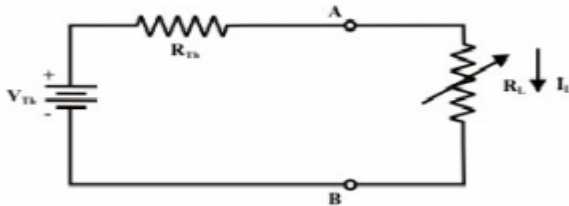

In above figure a variable load resistance  $R_L$  is connected to an equivalent Thevenin circuit of original circuit. The current for any value of load resistance is,

$$I_L = \frac{V_{TH}}{R_{TH} + R_L}$$

Then, the power delivered to the load is..

$$P_L = I_L^2 \times R_L \therefore P_L = \left( \frac{V_{TH}}{R_{TH} + R_L} \right)^2 \times R_L$$

Maximum power transfer occurs when the load resistance  $R_L = R_{TH}$ .

Substituting  $R_L = R_{TH}$  in the above equation, we get

$$P_L = \left[ \frac{V_{TH}}{R_L + R_L} \right]^2 R_L$$

$$= \left( \frac{V_{TH}}{2R_L} \right)^2 \times R_L$$

$$P_{Lmax} = \frac{V^2}{4R_L}$$

**Reciprocity Theorem :**

Statement:

In any linear bilateral network, if a source of emf  $E$  in any branch produces a current  $I$  in any other branch, then the same emf  $E$  acting in the second branch would produce the same current  $I$  in the first branch.

(OR)

each  
Explanat  
ion  
2M each

WINTER- 18 EXAMINATION

Subject Name: Electric circuits and network

Model Answer Subject Code:

22330

27

In any branch of a network or circuit, the current due to a single source of voltage (V) in the network is equal to the current through that branch in which the source was originally placed when the source is again put in the branch in which the current was originally obtained.

Explanation :

Consider the two circuits shown below.

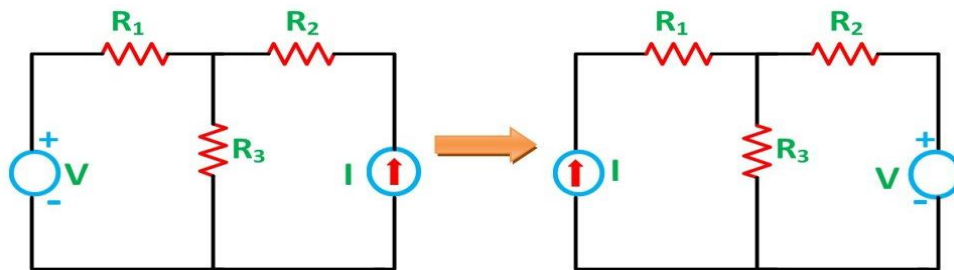

The various resistances  $R_1$ ,  $R_2$ ,  $R_3$  are connected in the circuit diagram above with a voltage source (V) in first loop and an ammeter in second loop in first circuit.

In the second circuit the positions of voltage source and ammeter are interchanged

According to Reciprocity Theorem, the ratio of  $V / I$  called transfer resistance. It remains same in both cases. In this way the theorem is useful for solving networks.

c) Explain significance of two-port network. Also draw two port network for  
(i) Cascade configuration ABCD parameter (ii) Series configuration

6M

Ans: Significance of two-port network:-

2M

A two-port network is regarded as a "black box" with its properties specified by a matrix of numbers. This allows the response of the network to signals applied to the ports to be calculated easily, without solving for all the internal voltages and currents in the network.

2M

Cascade configuration ABCD parameter :-

WINTER- 18 EXAMINATION

Subject Name: Electric circuits and network

Model Answer Subject Code:

22330

28

2M

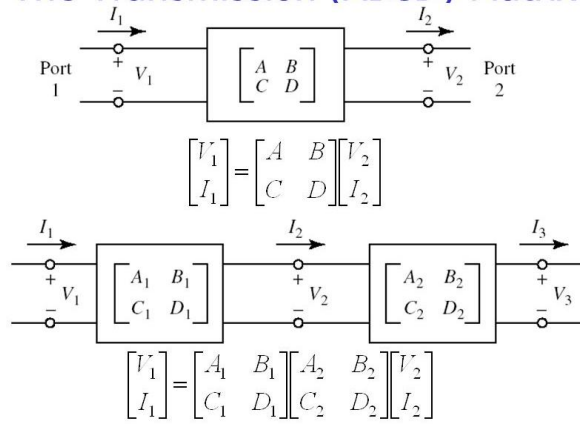

OR

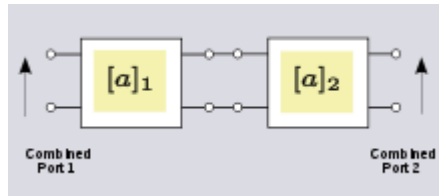

Series configuration:-

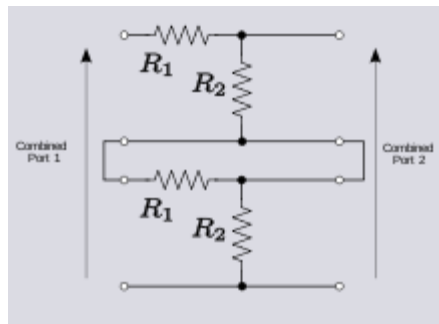

OR

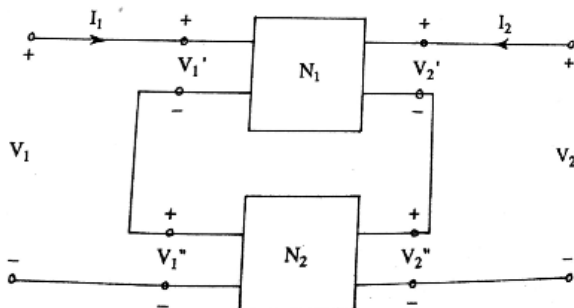



WINTER- 18 EXAMINATION

Subject Name: Electric circuits and network

Model Answer Subject Code:

22330

29

	Where $N_1$ and $N_2$ are two 2-port networks	
--	---	--