



MODEL ANSWER  
WINTER- 18 EXAMINATION

Subject Title: Applied Electronics

Subject Code: **22329**

3 Hours / 70 Marks

Important Instructions to examiners:

- 1) The answers should be examined by key words and not as word-to-word as given in the model answer scheme.
- 2) The model answer and the answer written by candidate may vary but the examiner may try to assess the understanding level of the candidate.
- 3) The language errors such as grammatical, spelling errors should not be given more Importance (Not applicable for subject English and Communication Skills).
- 4) While assessing figures, examiner may give credit for principal components indicated in the figure. The figures drawn by candidate and model answer may vary. The examiner may give credit for anyequivalent figure drawn.
- 5) Credits may be given step wise for numerical problems. In some cases, the assumed constant values may vary and there may be some difference in the candidate's answers and model answer.
- 6) In case of some questions credit may be given by judgement on part of examiner of relevant answer based on candidate's understanding.
- 7) For programming language papers, credit may be given to any other program based on equivalent concept.

Q. No.	Sub Q.N.	Answer	Marking Scheme
Q.1		Attempt any FIVE of the following :	10-Total Marks
	a)	Define the term related to power amplifier. (i) Efficiency (ii) Voltage gain	2M
	Ans:	<p>(i) <u>Efficiency</u>: Efficiency of the power amplifier is defined as the ratio of maximum a.c. output power to the d.c. input power. Mathematically,</p> <div style="border: 1px solid black; padding: 5px; width: fit-content; margin: 10px auto;"> <math display="block">\% \eta = \frac{P_o(ac)}{P_i(dc)} \times 100\%</math> </div> <p>(ii) <u>Voltage gain</u>: Voltage gain of the power amplifier is defined as the ratio of output voltage to the input voltage. Mathematically,</p> <div style="border: 1px solid black; padding: 5px; width: fit-content; margin: 10px auto;"> <math display="block">A_v = \frac{V_{out}}{V_{in}}</math> </div>	1 Mark for each definition

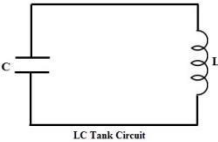

b)	List any four applications of RC coupled amplifier.	2M
Ans:	Applications of RC coupled amplifier: (i) Widely used as Voltage amplifiers. (ii) They are used in Public Address System. (iii) In Tape recorders. (iv) In stereo amplifiers (v) In T.V. V.C.R. and C.D. Players.	1 Marks each  (Any four)
c)	State the role of tuned LC circuit in tuned amplifier.	2M
Ans:	<p>In order to pick up and amplify the desired radio frequency signal, the resistive load in the audio amplifier is replaced by a tuned circuit (also called a parallel resonant circuit) as shown in the figure. The tuned circuit is capable of selecting a particular frequency and rejecting the others.</p>  <p>LC Tank Circuit</p> <p>Thus the use of tuned circuit in the transistor amplifier circuit, makes possible the selection and amplification of a particular desired radio frequency. Such an amplifier is called tuned voltage amplifier.</p> <p>Thus an amplifier, which amplifies a specific frequency (or a narrow band frequencies), is called a tuned voltage amplifier or simply tuned amplifier. It serves following two purposes:</p> <p>(i) Selection of desired radio frequency signal.</p> <p>(ii) Amplification of the selected signal to a suitable voltage level.</p>	State 1 ½ Marks and Diagram 1/2 mark
d)	List different types of feedback amplifiers.	2M
Ans:	<u>Types of feedback amplifiers:</u> 1. Positive feedback amplifiers 2. Negative feedback amplifiers (i) voltage series feedback amplifiers (ii) voltage shunt feedback amplifiers (iii) current series feedback amplifiers (iv) current shunt feedback amplifiers	Each type 1 mark
e)	List the advantages of negative feedback over positive feedback.	2M
Ans:	<u>Advantages of negative feedback over positive feedback:</u> 1. Higher fidelity i.e. more linear operation. 2. Highly stabilized gain. 3. Increased bandwidth i.e. improved frequency response.	Any four Each 1 mark

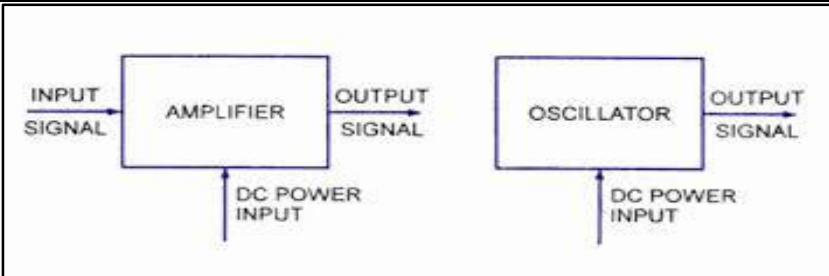
	<p>4. Less amplitude distortion.</p> <p>5. Reduced noise.</p> <p>6. Less harmonics distortion.</p> <p>7. Less phase distortion.</p> <p>8. Input and output impedance can be modified as desired.</p> <p>9. Less frequency distortion.</p>	
f)	Compare amplifier and oscillator.	2M
Ans:	<div style="border: 1px solid black; padding: 10px; margin-bottom: 10px;">  </div> <p>Figure shows a block diagram of an amplifier and an oscillator.</p> <p>An amplifier is a device, which produces an output signal with similar waveform as that of the input. But its power level is generally high. This additional power is supplied by an external D.C. source. Thus an amplifier is essentially an energy convection device I.e. a device, which gets energy from the D.C. source and converts it into an a.c. energy at the same frequency as that of the input signal. The D.C. to A.C.. conversion is controlled by the input signal. It means that if there is no input signal then no energy conversion take place. Thus there is no output signal.</p> <p>An oscillator is a device, which produces an output signal, without any input signal of any desired frequency. It keeps producing an output signal, so long as the D.C. power is supplied. An oscillator does not require any external signal to start or maintain energy conversion process.</p>	Diagram 1 mark and explanation 1 mark
g)	State use of heat sink.	2M
Ans:	<p>Heat sink is a heat exchanger used to transfer heat generated by a <i>mechanical or an electronic device</i> to the surroundings.</p> <p>Heat sinks are either made up of aluminium or copper or any other material which is good conductor of heat. Because conductor helps in conduction of heat from heated surface to the outside air.</p> <p>Heat sinks are commonly used in laptops, computers etc.</p> <p>A heat sink is usually made out of copper and/or aluminum.</p>	State 2 mark

Q 2	Attempt any THREE of the following :	12-Total Marks
a)	<p>Explain with the help of waveforms, the working principle of single stage CE amplifier.</p> <div style="text-align: center; border: 1px solid black; padding: 10px; margin: 10px 0;"> </div> <p><b>CIRCUIT DESCRIPTION:</b></p> <ul style="list-style-type: none"> <li>The input a.c. signal is applied across the base emitter terminals of the transistor &amp; output is taken across collector emitter terminals of the transistor. <math>V_{BB}</math> supply forward biases the emitter base junction &amp; <math>V_{CC}</math> supply reverse biases the output junction.</li> <li>The Q point is determined by the <math>V_{CC}</math> supply along with the resistance <math>R_C</math>. The resistances <math>R_1, R_2, R_E</math> form the biasing &amp; stabilization circuit &amp; thus establishes proper operating point.</li> <li>Input capacitor (<math>C_{in} \approx 10\mu F</math>): It blocks DC voltage to the base, if it is not provided the source resistance comes across <math>R_2</math>, so that transistor gets unbiased. It allows A.C. to pass &amp; isolates source resistance from <math>R_2</math>.</li> <li>Emitter capacitance (<math>C_E \approx 100\mu F</math>): it is used in parallel with <math>R_E</math> to provide a low reactance path to the amplified a.c. signal. If it is not used then amplified a.c. signal flowing through <math>R_E</math> will cause a voltage drop across it, thus reducing the output voltage.</li> <li>Coupling capacitor (<math>C_C \approx 10\mu F</math>): it couples one stage of amplification to the next stage. If it is not used, <math>R_C</math> comes across with the <math>R_1</math> of next stage &amp; biasing of 2<sup>nd</sup> stage gets disturbed. In short it isolates the d.c. of one stage from the next stage but allows the A.C. signal.</li> </ul> <p><b>PHASE REVERSAL / WORKING:</b></p> <ul style="list-style-type: none"> <li>Consider above common emitter amplifier circuit. The input a.c. signal is applied across the base emitter terminals of the transistor &amp; output is taken across collector emitter terminals of the transistor. <math>V_{BB}</math> supply forward biases the emitter base junction &amp; <math>V_{CC}</math> supply reverse biases the output junction.</li> <li>Now apply KVL to collector to emitter loop'</li> </ul> <p><math>V_{CC} - I_C R_C - V_{CE} = 0.</math></p>	4M
Ans:	<p style="text-align: right;">Circuit 2 M and explanation 1 M and waveform 1 M</p>	

$\therefore V_{CC} - I_C R_C = V_{CE}$ .....(1)

- When the input a.c. signal voltage increases, the base current increases as a result collector current increases (as  $I_C = \beta I_B$ ). Hence voltage drop  $I_C R_C$  increases. As  $V_{CC}$  is constant, from equation 1 output voltage  $V_{CE}$  decreases.
- From above in common emitter amplifier when the input increases in the positive, the output voltage decreases. i.e. output is  $180^\circ$  out of phase with input.

Waveform:

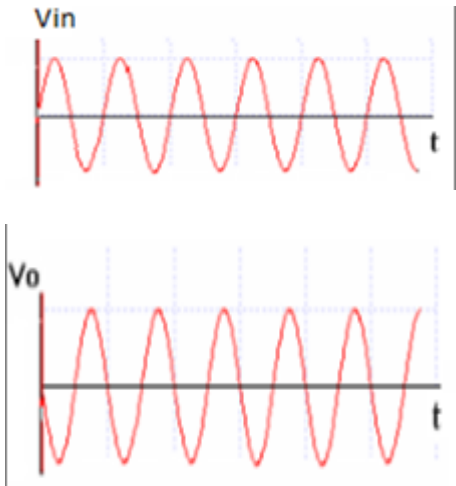

b) Compare positive and negative feedback.

4M

Ans:

Sr. No.	Parameter	Positive feedback	Negative feedback
1	BW	Increases	Decreases
1	Feedback signal	In phase with the input signal.	$180^\circ$ out of phase with the input signal.
2	Net input signal	Increases	Decreases
3	Gain	Increases	Decreases
4	Noise	Increases	Decreases
5	Stability	Poor	Improved
6	Input impedance	decreases	increases
7	Output impedance	increases	decreases
8	Uses	Oscillators, Schmitt trigger	Amplifiers, bootstrapping

Any four points  
Each point 1 M

c)	<p>Define oscillator and state the Barkhausen criterion for the generation of sustained oscillations.</p>				4M
Ans:	<p><u>Oscillator</u>: An oscillator is a device, which produces an output signal, without any input signal of any desired frequency.</p> <p><u>Barkhausen criterion</u>: The overall voltage gain of a positive feedback amplifier is given by,</p> <div style="border: 1px solid black; padding: 5px; width: fit-content; margin: 10px auto;"> <math display="block">A' = \frac{A}{1 - \beta A}</math> </div> <p style="text-align: right;">.....(1)</p> <p>Where, A = gain of an amplifier without feedback also called open loop gain  <math>\beta A</math> = product of feedback fraction and open loop gain. It is called loop gain.</p> <p>The Barkhausen criterion for the generation of sustained oscillations for positive feedback are:</p> <ol style="list-style-type: none"> <li>1. <math>\beta A = 1</math></li>   <li>2. <math>\angle \beta A = 360^\circ</math> or <math>0^\circ</math> i.e. the total phase shift should be <math>360^\circ</math> or <math>0^\circ</math>.</li> </ol>				<p>Definiti on 1 M and Barkhau sen criterion 3 M</p>
d)	<p>Explain the working of SMPS with neat block diagram.</p>				4M
Ans:	<div style="border: 1px solid black; padding: 10px; margin-bottom: 10px;"> </div> <p>A block diagram of Switch Mode Power Supply is shown in figure. The first block is rectifier and filter that converts the A.C. supply voltage to pulsating D.C. which is then filtered out to reduce the amount of ripple content. This section uses the power diodes in bridge configuration to obtain the pulsating d.c. and the capacitor is used as a filter element. The second block is the high frequency switching section and it uses either MOSFETs or BJTs to convert the D.C. voltage to a high frequency ac\c. square wave. This high frequency a.c. square waves ranges from 20 KHz to 100 KHz. Since the power transistors are not operated in their active region, their operation results in low power dissipation. Thus it is a two stage conversion i.e. the input a.c. supply voltage is first rectified to d.c. and then the high frequency switching section changes it back to A.C.</p> <p>The next block of SMPS is high frequency power transformer that isolate the circuit and step up or step down the voltage to the desired voltage level. The output of the transformer is the input of the second rectifier section, called the output rectifier section. This rectifier section is different from the first block of the rectifier in that the frequency of the voltage is very high. Therefore, the bridge configuration of this rectifier uses a high frequency diodes such as schottky diode and the output ripple is naturally filtered because of the number of the overlaps between each individual output pulse. Since the ripple is very</p>				<p>Block diagram 2 M And explanat ion 2 M</p>

		<p>small in output voltage of the rectifier, a small capacitance is required in the filter section.</p> <p>The last section of the SMPS is the control and feedback block, which contains circuitry that provides Pulse Width Modulation (PWM) output signal. The PWM controller provides duty cycle that varies pulse by pulse to provide an accurate d.c. output voltage.</p>	
Q.3		Attempt any THREE of the following :	12-Total Marks
	a)	Explain with sketch the working of class B push pull amplifier.	4M
	Ans:	<p>Circuit Diagram:-</p> <p><u>Operation:</u></p> <ul style="list-style-type: none"> <li>• In class B amplifier transistor conduct only for half cycle of input signal. One conduct in positive half cycle and other conducts in negative half cycle.</li> <li>• Transformer T<sub>1</sub> is called as input transformer called phase splitter and produces two signals which are 180 degree out of phase with each other.</li> <li>• Transformer T<sub>2</sub> is called as output transformer and is required to couple the a.c signal from the collector to the load.</li> <li>• When there is no input signals both the transistor Q<sub>1</sub> and Q<sub>2</sub> are cut off hence no current is drawn from V<sub>cc</sub> supply. Thus there is no power wasted in stand by the power dissipation in both transistor is practically zero.</li> <li>• During positive half cycle ON Q<sub>2</sub> OFF and at the output half cycle is obtained Q<sub>1</sub> during negative half OFF and Q<sub>2</sub> on hence another half cycle is obtained cycle Q<sub>1</sub> at the output.</li> <li>• Then output transformer joins these two halves and produces a full sine wave in the load resistor.</li> </ul>	<p>Circuit Diagram 2M &amp; Operation 2M</p>
	b)	Compare different types of power amplifier on basis of- (i) Efficiency.	4M

- (ii) Power dissipation in transistor.
- (iii) Conduction angle of collector current
- (iv) Position of Q.

Parameter	Class A	Class B	Class AB	Class C
Position of operating pt. (Q Point) on load line	Q point is at the center of load line.	On X axis	Just above X axis.	Below X axis.
Efficiency	lowest efficiency 25% to 50%	Above 78.5%	Between 50 to 78.5%	Above 95%
Conduction Angle of collector current	Conducts for (360°) full cycle of input signal	(180°) half cycle of input signal.	Greater than 180° and less than 360°	Less than 180° of input signal.
Power dissipation in transistor	Very High	Low	Low	Very Low

Each difference carry 1M

c) Draw miller sweep generation and give its applications.

4M

Diagram:

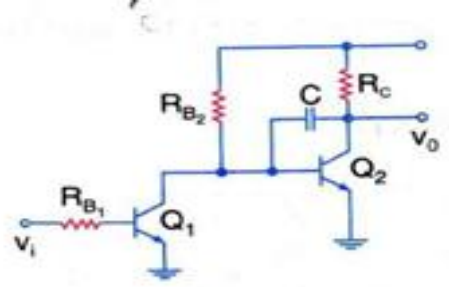

(a) Miller sweep circuit.

Ans:

- Applications of Miller Sweep Generator: (any two)
1. Applications where linear output is expected.
  2. Television (TV)
  3. CRO
  4. To convert step waveform into ramp waveform.

Diagram: 2M & Applications (any two) 2M



d)

Sketch the circuit diagram for dual voltage regulator using IC 78XX and 79XX to obtain  $\pm 12V$  output.

4M

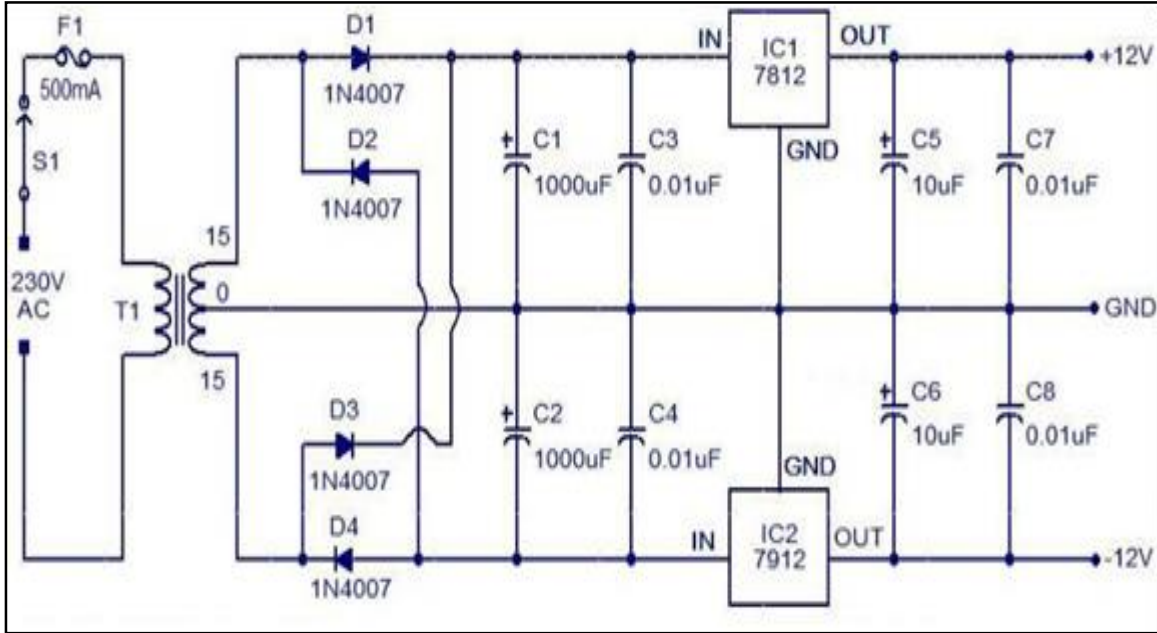

OR

Ans:

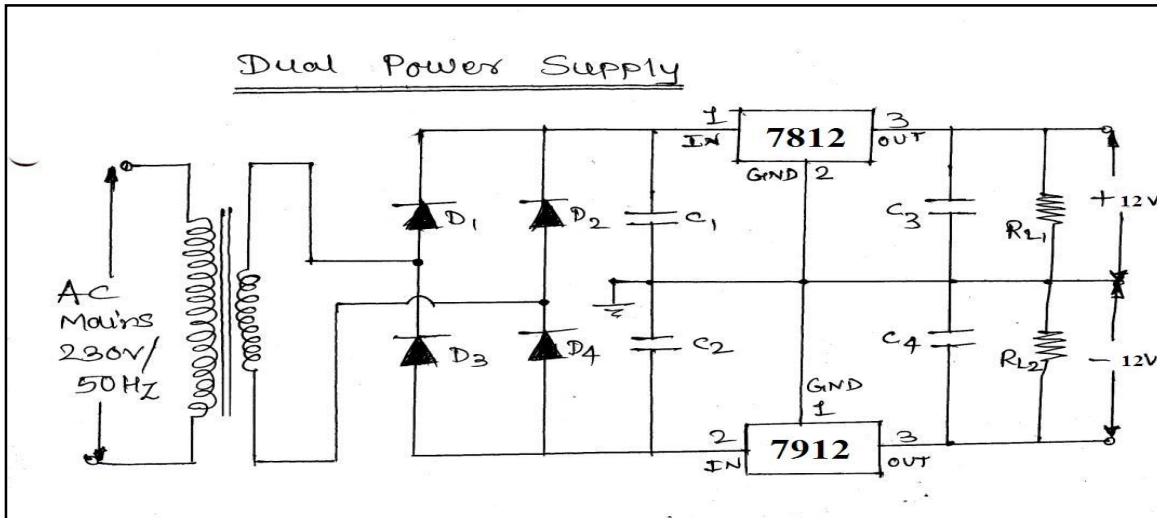

Q.4	A)	Attempt any THREE of the following :	12-Total Marks
	a)	State the necessity of regulated power supply. Define load and line regulation.	4M
	Ans:	<p><u>Necessity of regulated power supply: 2M</u></p> <p>The major disadvantage of a power supply is that the output voltage changes with the variations in the input voltage or The D.C output voltage of the rectifier also increase similarly, In many electronic applications, it is desired that the output voltage should remain constant regardless of the variations in the input voltage or load. In order to get ensure this; a voltage stabilizing device called voltage regulator is used.</p> <p><u>Load Regulation: 1M</u></p> <p>The load regulation indicates the change in output voltage that will occur per unit change in load current. Mathematically,</p> $\text{Load Regulation} = \frac{V_{NL} - V_{FL}}{\Delta I_L}$ <p>Where, <math>V_{FL}</math> is full load voltage <math>\Delta I_L</math> is change in load current <math>V_{NL}</math> is no load voltage</p> <p><u>Line Regulation: 1M</u></p> <p>The change in output voltage with respect to per unit change in input voltage is defined as line regulation. It is mathematically expressed as,</p> $\text{Line regulation} = \Delta V_L / \Delta V_S$ <p>Where, <math>\Delta V_L</math> = The change in output voltage <math>\Delta V_S</math> = The change in input voltage</p>	Necessity 2M , Load Regulation 1M & Line regulation 1M
	b)	Explain the working principle of crystal oscillator with diagram.	4M
	Ans:	<p><u>Circuit Diagram:</u></p>	



Working Principle of Piezoelectric Crystal:

- A Quartz Crystal has a very peculiar property known as Piezoelectric Effect.
- According to this effect, when an AC voltage is applied across a quartz crystal, it vibrates at a frequency of applied voltage.
- Conversely, if a mechanical force is applied to vibrate a quartz crystal it generates an AC voltage.
- Above fig shows the circuit of crystal oscillator using transistor. In this circuit, the crystal is connected as a series element in the feedback path from collector to the base.
- The resistors R<sub>1</sub>, R<sub>2</sub> and R<sub>E</sub> provide voltage divider stabilized d.c. bias circuit. The capacitor C<sub>E</sub> provides a.c bypass of emitter resistor and RFC coil provides for d.c bias. The coupling capacitor C has negligible impedance at the circuit operating frequency.
- The circuit frequency of oscillation is set by the series resonant frequency of the crystal and its value is given by the relation

$$f_r = \frac{1}{2\pi\sqrt{LC}}$$

Or

Working Principle:

When the D.C. power is switched on, the noise voltage of small amplitude appearing at the base gets amplified and appears at the output. This amplified noise now drives the feedback network consisting of a quartz crystal and capacitor C. Thus the crystal is excited by a fraction of energy feedback from the output to the input. The crystal is made to operate as an inductor L so that the feedback network consists of series resonant LC circuit. This is possible only, if the frequency of oscillations f<sub>0</sub> is in between the series resonant frequency f<sub>s</sub> and the parallel resonant frequency f<sub>p</sub> of an electrical equivalent circuit of a crystal. Thus, the frequency of oscillations is set by the series resonant frequency f<sub>s</sub> of the crystal. This produces undamped oscillations of stable frequency f<sub>0</sub>.

$$f_r = \frac{1}{2\pi\sqrt{LC}}$$

c) Compare the performance of current series and current shunt feedback amplifier. 4M

	Sr.No.	Characteristics	Current series feedback amplifier	Current shunt feedback amplifier	
Ans:	1.	Voltage gain	Decreases	Decreases	(Any Four) each carry 1M
	2.	Bandwidth	Increases	Increases	
	3.	Harmonic distortion	Decreases	Decreases	

4.	Noise	Decreases	Decreases
5.	Input resistance	Increases	Decreases
6.	Output resistance	Increases	Increases

d) Describe with help of circuit diagram working of class A power amplifier.

4M

**Circuit Diagram:**

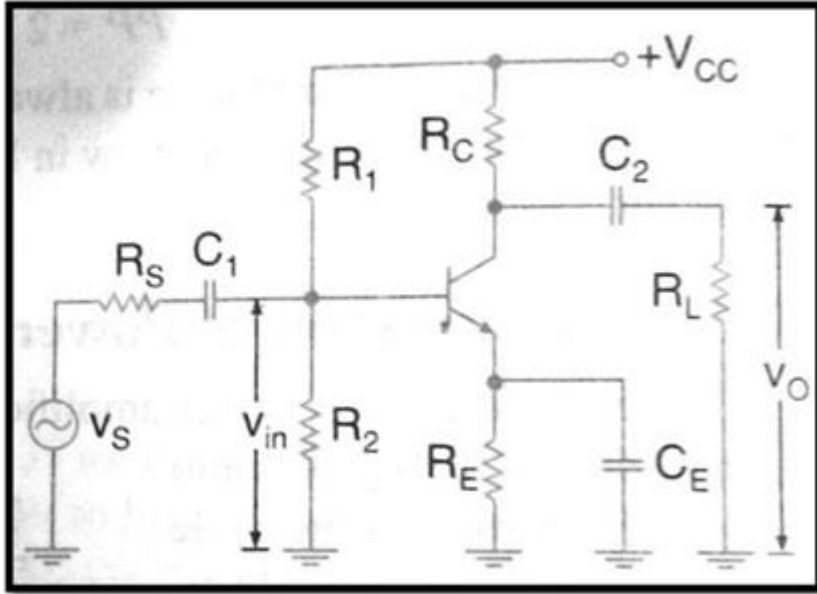

Working:

Ans:

The input a.c. signal is applied across the base emitter terminals of the transistor & output is taken across collector emitter terminals of the transistor.  $V_{BB}$  supply forward biases the emitter base junction &  $V_{CC}$  supply reverse biases the output junction.

The Q point is determined by the  $V_{CC}$  supply along with the resistance  $R_C$ . The resistances  $R_1, R_2, R_E$  form the biasing & stabilization circuit & thus establishes proper operating point.

Input capacitor ( $C_{in} \approx 10\mu F$ ): It blocks DC voltage to the base, if it is not provided the source resistance comes across  $R_2$ , so that transistor gets unbiased. It allows ac to pass & isolates source resistance from  $R_2$ .

Class A amplifier is basically, a common emitter amplifier. This circuit is called direct coupled class A power amplifier. The only difference between this circuit and small signal version, considered earlier, is that the signals handled by the power amplifier circuit are in the range of volt.

Or

Circuit Diagram:

Circuit Diagram 2M & Working 2M

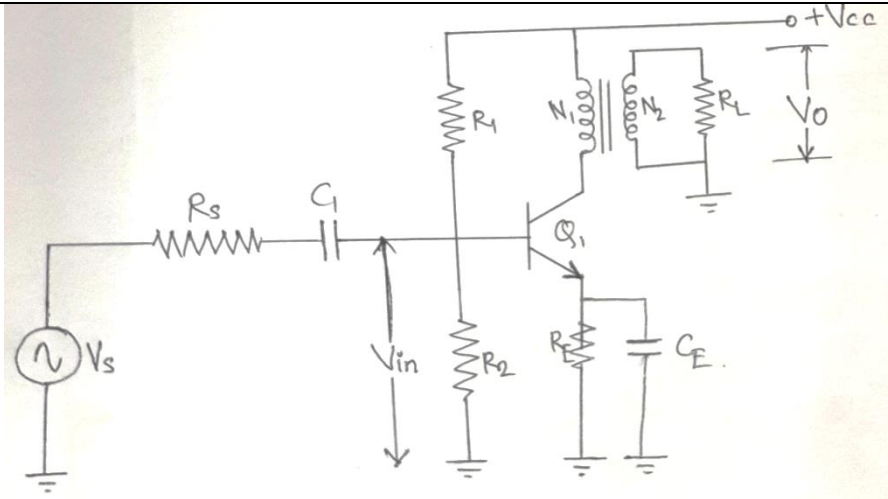

e) Compare single tuned and double tuned amplifier with respect to operating principle, frequency response, efficiency and applications.

Sr.No.	Characteristics	Single tuned amplifier	Double tuned amplifier
1.	Operating Principle	Parallel Resonance	Parallel Resonance
2.	Frequency response		
3.	Efficiency	High	Low
4.	Application	TRF receiver, TV receiver	IF amplifier in Radio receiver, TV receiver

Ans:

Q.5	Attempt any TWO of the following :	12- Total Marks
-----	------------------------------------	-----------------------

a)	Explain with diagram the working of phase shift oscillator. Also a phase shift oscillator has $R = 220\text{ k}\Omega$ and $C = 500\text{ pf}$ . Calculate the frequency of sine wave generated by the oscillator.	6M
----	--	----

Circuit Diagram of RC PHASE SHIFT OSCILLATOR:

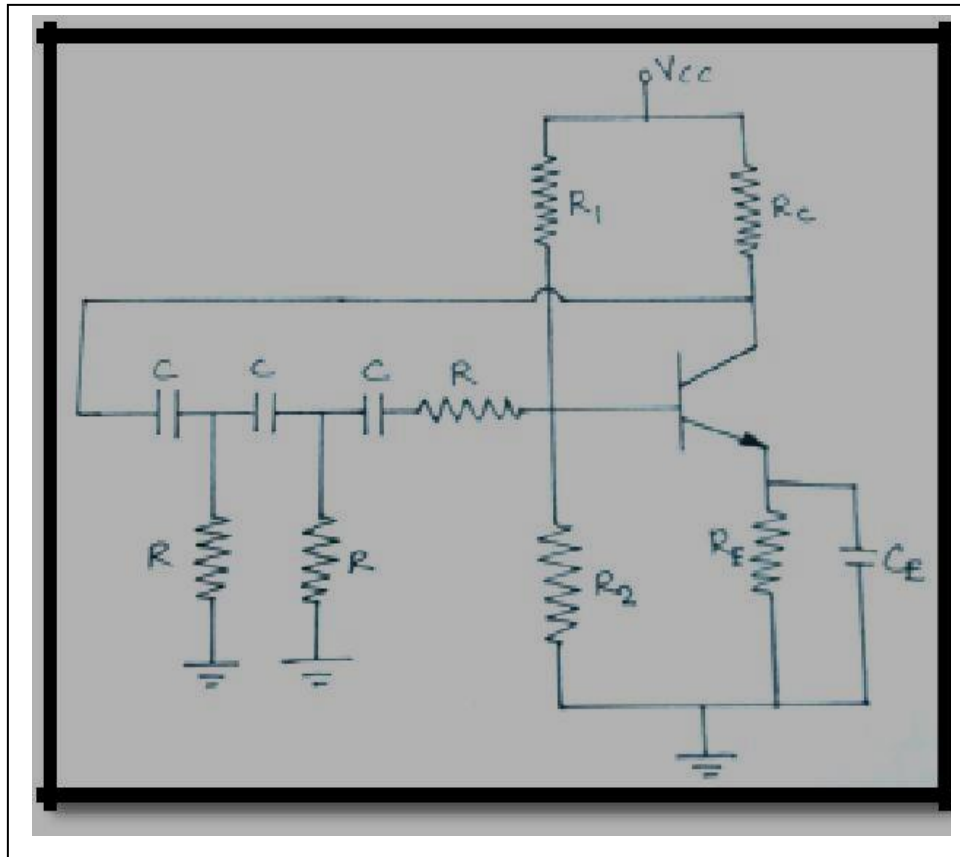

Ans:

Circuit Diagram: 2M  
 Working: 2M  
 Calculation for  $f_o = 2M$

OR

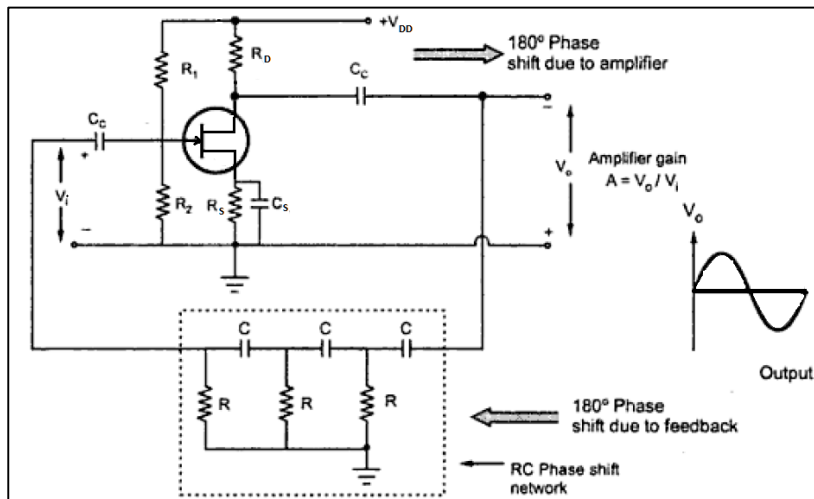



	<p><u>WORKING:</u></p> <ul style="list-style-type: none"> <li>• Common emitter amplifier introduces a <math>180^{\circ}</math> phase shift between input &amp; output. &amp; remaining <math>180^{\circ}</math> phase shift is produced by three identical basic RC phase shifting networks.</li> <li>• Each RC network is designed to introduce a phase shift of <math>60^{\circ}</math>.</li> <li>• The phase shift around the loop is <math>360^{\circ}</math> only at one precise frequency.</li> <li>• This frequency of oscillation is given by</li> </ul> $f_o = \frac{1}{2 \pi RC \sqrt{6}}$ <ul style="list-style-type: none"> <li>• The feedback factor <math>\beta = \frac{1}{29}</math></li> <li>• Therefore <math>A_V = 29</math></li> </ul> <p>Calculation For <math>f_o</math>: Given: R= 220 K<math>\Omega</math> C= 500pF To Find: Frequency of oscillation <math>f_o</math>. Formula Used: <math>f_o = \frac{1}{2 \pi RC \sqrt{6}}</math> Solution: <math>f_o = \frac{1}{2 \pi RC \sqrt{6}}</math></p> $f_o = \frac{1}{2 \pi * 220K\Omega * 500pF * \sqrt{6}}$ <p><math>f_o = 590.67</math> Hz</p> <p>The frequency of sine wave generated by the oscillator = 590.67 Hz.</p>	
b)	Explain operation of FET common source amplifier with applications.	6M
Ans:	<p>COMMON SOURCE FET AMPLIFIER: <u>Circuit Diagram:</u></p>	<p>Circuit Diagram: 2M Operation: 2M Applications (any 2): 2M</p>

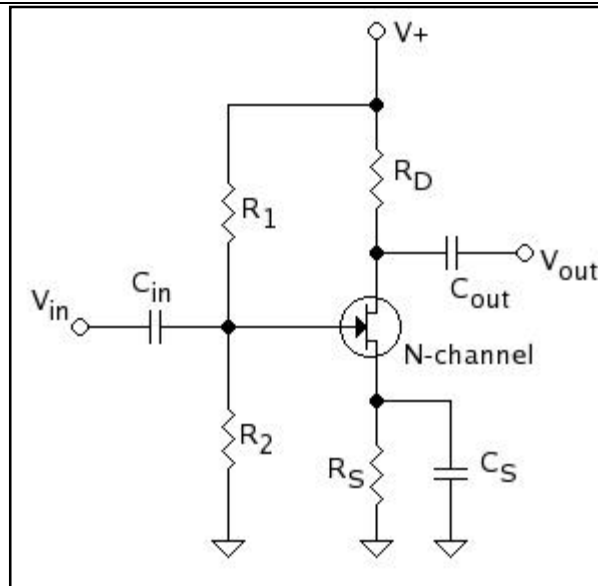

- Above circuit shows CS N-channel FET amplifier.
- Voltage divider biasing circuit is used.
- $C_1$  &  $C_2$  are coupling capacitors used to couple input AC signal & output respectively.
- $C_S$  is a bypass capacitor which keeps the source of FET effectively.

#### OPERATION:

##### DURING POSITIVE HALF CYCLE:

- As the gate to source voltage increases, the drain current also increases.
- As a result of this, the voltage drop across resistor  $R_D$  also increases.
- This causes the drain voltage to decrease. As  $V_{DS} = V_{DD} - I_D R_D$ .
- It means that the positive half cycle of the input produces negative half cycle of the output voltage.
- In other words output voltage is 180 out of phase with the input voltage.

##### DURING NEGATIVE HALF CYCLE:

- As the gate to source voltage decreases, the drain current also decreases.
- As a result of this, the voltage drop across resistor  $R_D$  also decreases.
- This causes the drain voltage to increase. As  $V_{DS} = V_{DD} - I_D R_D$ .
- It means that the negative half cycle of the input produces positive half cycle of the output voltage.
- In other words output voltage is 180 out of phase with the input voltage.

#### APPLICATIONS OF CS-FET AMPLIFIER:

- As a pre-amplifier in audio circuits.
- As a voltage amplifier.
- In the public address system.
- In radio & TV amplifier circuit.



c)	<p>Explain with circuit diagram and waveform the operation of class AB push pull power amplifier</p>	6M
Ans:	<p><b>Class AB Push Pull Power Amplifier:</b> <b>Circuit Diagram:</b></p> <p><b>Circuit Description:</b> The circuit consists of two centre-tapped transformers <math>T_1</math> and <math>T_2</math>, two identical transistors <math>Q_1</math> and <math>Q_2</math>, Resistor <math>R</math> and diode <math>D</math>. The DC voltage developed across the diode <math>D</math> is connected to the bases of both the transistors through the secondary winding of the input transformer. This voltage acts as DC bias for the transistors because it is equal to cut-in voltage and they will conduct for complete half cycle period of the input to eliminate the cross-over distortion.</p> <p><b>WORKING:</b></p> <ul style="list-style-type: none"> <li>➤ When there is no a.c. input signal is applied both the transistors <math>Q_1</math> &amp; <math>Q_2</math> are cut off. Hence no current is drawn from <math>V_{CC}</math>.</li> <li>➤ <b>DURING POSITIVE HALF CYCLE:</b> <ul style="list-style-type: none"> <li>• The base of the transistor <math>Q_1</math> is positive and that of <math>Q_2</math> is negative.</li> <li>• As a result of this <math>Q_1</math> conducts, while the transistor <math>Q_2</math> is OFF.</li> </ul> </li> <li>➤ <b>DURING NEGATIVE HALF CYCLE:</b> <ul style="list-style-type: none"> <li>• The base of the transistor <math>Q_2</math> is positive and that of <math>Q_1</math> is negative.</li> <li>• As a result of this <math>Q_2</math> conducts, while the transistor <math>Q_1</math> is OFF.</li> </ul> </li> <li>➤ Thus at any instant any one transistor in the circuit is conducting.</li> <li>➤ Then the output transformer joins these two halves &amp; produces a full sine wave in the load resistor.</li> </ul>	<p>Circuit Diagram: 2M Operation: 2M Waveform: 2M</p>

		<p><u>Waveform:</u></p> <div style="text-align: center;"> <p style="text-align: center;">Class AB Amplifier Operation</p> </div>	
Q.6		Attempt any TWO of the following:	12- Total Marks
	a)	Explain stagger tuned amplifier with the help of waveforms.	6M
Ans:		<p><u>Circuit Diagram:</u></p> <div style="text-align: center;"> </div> <p>Above figure shows two-stage tuned voltage amplifier. The stagger tuning in this circuit, may be achieved by resonating the tuned circuits <math>L_1C_1</math> and <math>L_2C_2</math> to slightly different frequencies.</p> <p><u>Frequency Response:</u></p>	<p>Circuit Diagram: 2M Waveform (Frequency Response): 2M Explanation: 2M</p>

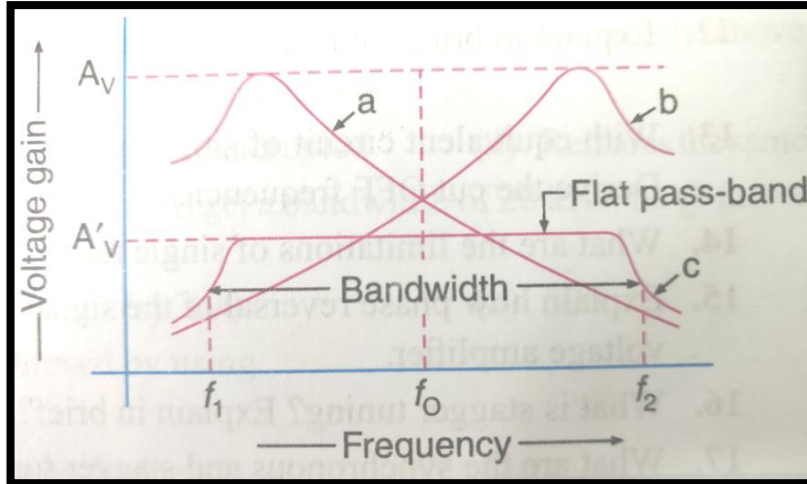

Above figure shows frequency response of a stagger-tuned amplifier. In this figure, curve 'a' shows the gain versus frequency of the  $L_1C_1$  tuned circuit. Similarly the curve 'b' shows the response of the  $L_2C_2$  tuned circuit. The curve 'c' indicates the combined response of the circuit. It is evident from this curve that the amplifier has a greater bandwidth and flatter pass-band. It has been found that more the number of stages used, flatter will be the pass-band and steeper will be the gain fall-off outside the pass-band. Because of the stagger tuning there is a loss of voltage gain.

b) Draw the circuit of complementary, symmetry push pull amplifier and explain its working.

6M

### COMPLEMENTRY SYMMETRY CLASS B PUSH PULL AMPLIFIER

Circuit Diagram:

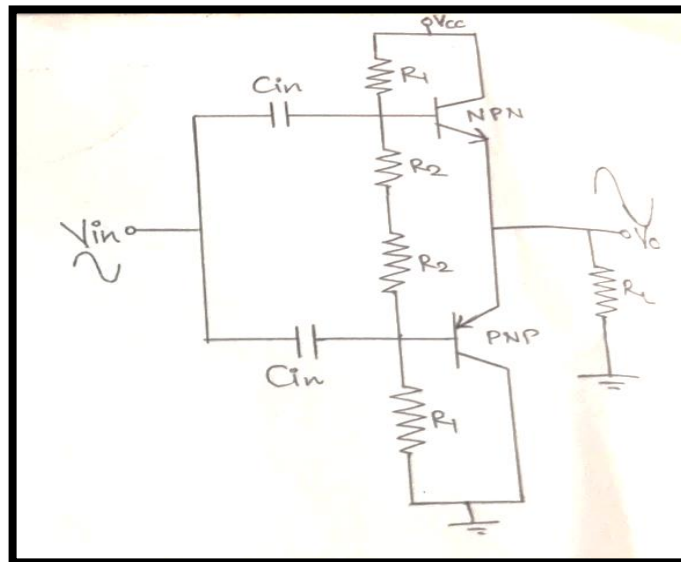

Ans:

Circuit description:

- Two transistors one NPN & other PNP is used in the circuit so they are complementary to each other.
- Biasing conditions used for both transistors are same so they are symmetrical.
- $R_1$ ,  $R_2$ ,  $V_{CC}$  are used for voltage divider bias of transistors.
- Both transistors conduct for  $180^\circ$  as it is class B amplifier.
- Whenever one transistor is ON other push to be OFF so the name push pull.

Circuit diagram : 2m  
Circuit description: 1m  
Working: 2m  
Waveform: 1m



	<p><b>Working:</b></p> <ul style="list-style-type: none"><li>➤ Input signal <math>V_{in}</math> is applied to both the transistor through input capacitor.</li><li>➤ During positive half cycle of input:<ul style="list-style-type: none"><li>• The base of the transistors NPN &amp; PNP is positive.</li><li>• As a result of this NPN conducts &amp; PNP remains OFF.</li><li>• So we get half cycle in the output.</li></ul></li><li>➤ During negative half cycle of input:<ul style="list-style-type: none"><li>• The base of the transistors NPN &amp; PNP is negative.</li><li>• As a result of this PNP conducts &amp; NPN remains OFF.</li><li>• So we get remaining half cycle in the output.</li></ul></li></ul>	
c)	<p>In voltage amplifier output voltage without negative feedback is 10V. If 25% of output voltage its feedback in series with input voltage. Find Feedback voltage, also give value of the feedback factor.</p>	6M
Ans:	<p><b>Given Data:</b> <math>V_{OUT} = 10V</math> 25% of output voltage its feedback in series with input voltage.</p> <p><b>To find:</b></p> <ol style="list-style-type: none"><li>1. Feedback voltage <math>V_F</math></li><li>2. Feedback factor <math>\beta</math></li></ol> <p><b>Solution:</b></p> <ol style="list-style-type: none"><li>1. Feedback voltage <math>V_F</math>: 25% of output voltage its feedback in series with input voltage. i.e. <math>V_F = 25\%</math> of <math>V_{OUT}</math> <math>V_F = 25\%</math> of 10V <math>V_F = 2.5V</math></li><li>2. Feedback factor <math>\beta</math>: <math display="block">\beta = \frac{V_F}{V_{OUT}}</math> <math display="block">\therefore \beta = \frac{2.5V}{10V}</math> <math display="block">\therefore \beta = 0.25</math></li></ol> <div style="border: 1px solid black; padding: 5px; width: fit-content; margin-top: 10px;"><ol style="list-style-type: none"><li>1. Feedback voltage <math>V_F = 2.5V</math></li><li>2. Feedback factor <math>\beta = 0.25</math></li></ol></div>	Calculation of feedback voltage: 3m Calculation of feedback factor: 3m