

LECTURE NOTES

ON

BUILDING MATERIALS, CONSTRUCTION AND PLANNING

PREPARED BY

**MRS. S. BHAGYALAXMI
ASSISTANT PROFESSOR.**

**MR. K. TARUN KUMAR
ASSISTANT PROFESSOR**



**Department of Civil Engineering
INSTITUTE OF AERONAUTICAL ENGINEERING
(AUTONOMOUS)
Dundigal – 500 043, Hyderabad**

UNIT- I

STONES, BRICKS AND AGGREGATES

BUILDING STONES:

Man requires different types of buildings such as houses, bungalows, flats etc for His living. For his activities man also require Hospitals for his health; Schools, Colleges and Universities for his education; Banks, Shops, Offices and Factories for doing works; Railway buildings, Bus stations and Air terminals for his transportation; Clubs and Theatres for recreation and Temples, Mosques, Churches etc for worship. Each type of the above buildings has its own requirements and needs building stones to construct the same. The period from 1750 A D onwards is known as the period of

Modern Architecture:

The use of reinforced concrete in construction triggered the rapid development of modern architecture. Structural components such as Columns, RCC slabs became increasingly popular because of the increased speed in construction. Use of plywood, glass, decorative materials etc helped the designers to make the new structures look more elegant in addition to the usage of various building stones. So, the engineering structures are composed of materials and are known as the engineering materials (or) building materials. Hence, Building materials have an important role to play in this modern age of technology. Building stones are obtained from rocks, are derived into three groups viz., Igneous, Sedimentary and Metamorphic rocks.

All the building structures are composed of different types of materials. These materials are either called building materials or materials of construction. It is very essential for a builder, may be an architecture or engineer or contractor, become conversant thoroughly with these building materials.

The knowledge of different types of material, their properties and uses for different purposes provides an important tool the hands of the builders in achieving economy in material cost. The material cost in a building ranges 30 to 50 percent cost of total cost construction. In addition to material economy, the correct use of material results in better structural strength, functional efficiency and esthetic appearance

Classification of Rocks:

Building stones are obtained from rocks occurring in nature and classified in three ways.

1. Geological classification
2. Physical classification
3. Chemical classification

Geological Classification:

According to this classification, the rocks are of the following types.

a. Igneous rocks: Rocks that are formed by cooling of magma (molten or pasty rocky material) are known as igneous rocks.

Eg: Granite, Basalt and Dolerite etc.

b. Sedimentary rocks: these rocks are formed by the deposition of products of weathering on the pre-existing rocks.

Examples: gravel, sandstone, limestone, gypsum, lignite etc.

c. Metamorphic rocks. These rocks are formed by the change in character of the pre-existing rocks. Igneous as well as sedimentary rocks are changed in character when they are subject to great heat and pressure known as metamorphism.

Examples: Quartzite, Schist, Slate, Marble and Gneisses.

Physical Classification:

This classification based on general structure of rocks. According to this, the rocks are classified into three types

a. Stratified Rocks: These rocks possess planes of stratification or cleavage and such rocks can be easily split along these planes

Ex: sedimentary rocks

b. An stratified rocks: The structure may be crystalline granular or compact granular. Examples: Igneous rocks and Sedimentary rocks affected by movements of the earth.

c. Foliated Rocks: These rocks have a tendency to split up in a definite direction only. Ex: Metamorphic rocks.

Chemical Classification:

According to this classification rocks are classified into three types.

a. Siliceous rocks: In these rocks, silica predominates. The rocks are hard; durable and not easily affected by weathering agencies. Ex: Granite, Quartzite, etc.

b. Argillaceous Rocks: In these rocks, clay predominates. The rocks may be dense and compact or may be soft.

Ex: slates, Laterites etc.

c. Calcareous rocks: In these rocks, calcium carbonate predominates. The durability of these rocks will depend upon the constituents present in surrounding atmosphere. Ex: Lime Stone, marble etc.

Uses of stones:

1. **Structure:** Stones are used for foundations, walls, columns, lintels, arches, roofs, floors, damp proof course etc.
2. **Face works.** Stones are adopted to give massive appearance to the structure. Wall is of bricks and facing is done in stones of desired shades. This is known as composite masonry.
3. **Paving stones:** These are used to cover floor of building of various types such as residential, commercial, industrial etc. They are also adopted to form paving of roads, foot paths etc.
4. **Basic material:** Stones are disintegrated and converted to form a basic material for cement concrete, morum of roads, calcareous cements, artificial stones, hallow blocks etc.
5. **Misalliances:** Stones are also used for (i) ballast for Railways (ii) flux in blast furnace (iii) Blocks in the construction of bridges, piers, abutments, retaining walls, light houses, dams etc.

Qualities of a good building stone:

The following are the qualities or requirements of a good building stone.

1. **Crushing strength:** For a good building stone, the crushing strength should be greater than 1000kg per cm².
2. **Appearance:** Good building stone should be a uniform colour, and free from clay holes, spots of other colour bands etc capable of preserving the colour for longtime.
3. **Durability:** A good building stone should be durable. The factors like heat and cold alternative wet and dry, dissolved gases in rain, high wind velocity etc affect the durability.
4. **Fracture:** For good building stone its fracture should be sharp, even and clear.
5. **Hardness:** The hardness greater than 17, treated as hard used in road works. It is between 14 to 17, medium hardness, less 14 said be poor hardness.
6. **Percentage wear:** For a good building stone, the percentage wear should be equal to or less then 3 percent.
7. **Resistance to fire:** A good building stone be fire proof. Sandstone, Argillaceous stone resists fire quite well
8. **Specific gravity:** For a good building stone the specific gravity should be greater then 8.7 or so.
9. **Texture:** A good building stone should have compact fine crystalline structure should be free from cavities, cracks or patches of stuff or loose material.
10. **Water absorption:** For a good building stone, the percentage absorption by weight after 24 hours should not exceed 0.60.

11. **Seasoning:** Stones should be well seasoned before putting into use. A period of about 6 to 12 months is considered to be sufficient for proper seasoning.

12. **Toughness Index:** Impact test, the value of toughness less than 13 – Not tough, between 13

Selection of stones

In contemplating the use of stone for various engineering works, the selection of the nature and quality of stone is governed by the purpose in view, cost of stone, its ornamental value and durability. Suitability various types of stones for different purposes and situation is briefly discussed below

a. For face work, in general marble, granite and close-grained sand stone are used in the form of thin slabs (veneers) where the structure subjected to adverse weather effects.

b. For pillars, balustrade, pedestals, columns statues and door and window sill and paving stone, granite marble and compact lime stone can be recommend because they can take good polish.

c. For ornamental works such as molding and carvings, fine grained sand stone, fine grained marble and fine grained granite are used.

d. For bridges, piers, docks, break-waters and other marine structures the stone should be very hard, heavy, strong and durable granite and gneiss are recommended for this purpose

e. For road metal, stones should be hard, tough, resistant to abrasion and durable. Basalt and coarse-grained granite are generally recommended for this purpose.

f. For railway ballast, the stone should be hard, dense, durable, tough and easily workable sandstone, compact lime stone, trap and quartzite are commonly used

g. In situation like steps, doors sills, pavings etc where there is a regular flow of traffic, stone should be hard, dense, easily workable and durable. Marble, slates and sand stones are commonly use in such places.

h. In fire proof construction, compact sand stone should always be preferred.

Artificial stones: These are also known as cast stones or reconstructed stones. Artificial stones may take up various forms such as

a. Cement concrete: This is the mixture of cement, fine aggregates, coarse aggregates and water. It may be cast in site. or pre-cast if steel is used with cement concrete, it is known as reinforced cement concrete.

b. Mosaic tiles: Pre-Cast concrete tiles with marble chips at top surface are known as tiles. They are available in different shades and widely adopted at present.

c. Terrazzo: This is a mixture of marble chips and cement. It is used for bathrooms residential buildings, temples etc.

Advantages of artificial stones:

1. Cavities may be kept in artificial stones to convey pipes, electric wires etc.
2. Grooves can be kept in artificial stone while it is being cast which are useful for fixing various fittings.
3. It can cast in desired shape
4. It can be made in a single piece and hence trouble of getting large blocks of stone for lintels, beams etc is avoided.
5. It can be made stronger than natural stone
6. It is cheap and economical
7. It is more durable than natural stone
8. Natural bed is absent in artificial stones and hence, the question of taking precautions with respect to the natural bed of stones does not arise.

QUARRYING OF STONES:

The process of taking out stones from exposed surface of natural rock bed is known as the quarrying. While selecting a quarry site, one should remember that the availability of quantity; desired quality, transportation facilities, cheap local labor, and free from the permanent structures in the vicinity, drainage of rainwater etc. In case of a quarry, the operations are carried out at ground level (in an exposed condition) whereas in case of mine, the operations are carried out under the ground at greater depths.

SELECTION OF A SITE FOR QUARRYING:

- Availability of Raw material, Tools, Power, Labor
- Space for dumping of refuse material.
- Distance of quarry from roads, railways.
- Proximity to the transportation facilities.
- Easy availability of clean water in sufficient quantity throughout the year.
- Economy in quarrying
- Blasting material availability

STONE QUARRYING TOOLS

Tamping Bar:

A tamping bar has a small blade at one end for loosening compacted or rocky soil and a flattened end for tamping..

Shovels: Shovels are available in various shapes and handle lengths. Shovels are most common for trail work and are used to move loosened soil, to dig trenches. They can also be used for cleaning of culvert outlets.

Post Hole Digger: Used for removing soil from holes. Soil should be lifted from the holes.

Sledge hammer: A sledgehammer with a 6 to 8pound head and a 3 foot-long handle is most useful for trail work. It can be used to crush rock into gravel.

Single Jack Hammer: A single jack (3 to 4pound head with short handle) hammer can be used with a star drill to punch holes in rock.

Star Drill: Star drills are usually about a foot long and weigh a pound. They are used with single jackhammers to punch holes in rock.

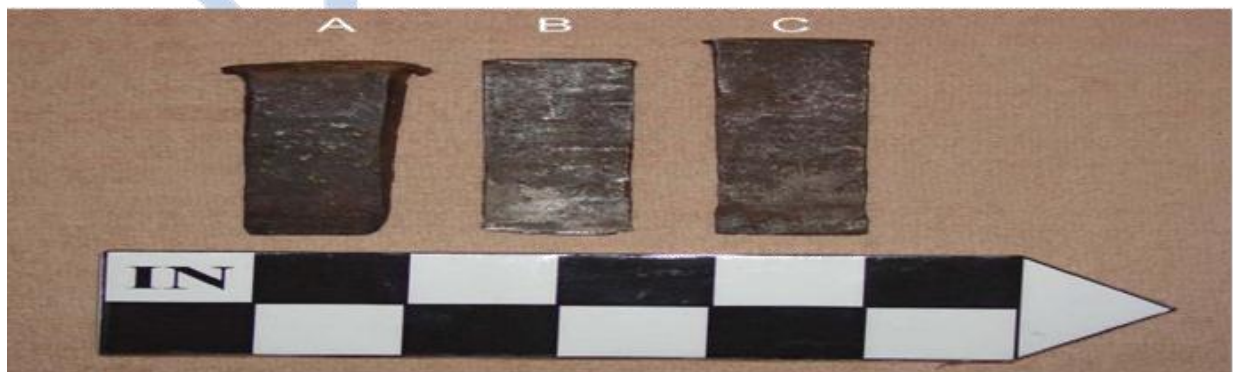

Two feathers (shims) with a plug (wedge) between them

HAND PLUG DRILLS:

METHODS OF QUARRYING:

The purpose of quarrying is to obtain building stones for various engineering purposes. Depending upon the nature of rocks and the purpose for which stones are needed, quarrying is done by adopting the following methods:

Quarrying is carried out by employing hand tools for digging / excavation, Heating, Wedging and Blasting.

1. **Digging / excavation:** In this method, the stones are merely excavated with the help of suitable hand tools such as Pick axes, Hammers, Spades, Chisels. This method is useful when soft stones occur in the form of small blocks.
2. **Heating:** In this method, the surface of rock is heated by placing pieces of wood or by piling a heap of fuel over the surface and fired for a few hours. Due to unequal expansion, the upper layer of rock separates out. The detached portion of rock is then removed by suitable hand tools.

This method is suitable when the rock formation consists of horizontal layers of shallow depth. Sometimes, intermediate layers are to be separated from the top and bottom layers. In such a case, the intermediate layer is heated and the expansion separates it from the other two.

3. **Wedging:** This method of quarrying is usually adopted for rocks such as Sandstone, Limestone, Marble, Slate, Laterite etc.. About 10 – 15 cm deep holes, at around 10 cm spacing are made vertically in the rock. Steel Pins and Wedges or Plugs are inserted in them. These plugs are then struck simultaneously with sledge hammer. The rock splits along the lines of least resistance through the holes.

4. **Blasting:** In this method, the explosives are used to convert rocks into small pieces of Stones and the main purpose of quarrying stones by blasting is to loosen large masses of rocks. Explosives such as Gun powder (Blasting powder), Dynamite, (Gelatin), Detonators, Fuse coil etc. are used.

The blasting powder and dynamite are commonly used as the explosives. The blasting powder is also known as the Gun Powder which is a mixture of charcoal, salt petre (KNO_3) and sulphur.

Fuses: It is required to ignite the explosives. It is in the form of a small rope of cotton coated with tar and with a core of continuous thread of fine gun powder. The rate of burning of a good fuse is about 10 mm per second.

Gun cotton: The clean cotton is saturated in a mixture of nitric acid and sulphuric acid. It is pressed into blocks or sticks while it is wet. It is as strong as dynamite. But its shattering power is less.

Liquid Oxygen: It is oxygen in liquid state. It is stored in a special container. It is comparatively cheap and used for blasting on a large scale for mining operations.

COMPARISION OF BLASTING POWDER AND DYNAMITE

Item	Blasting Powder	Dynamite
Action in quarrying	Large blocks of stones are obtained	S mall blocks of stones are obtained
Cost	Cheap	High cost and is about 5 times than that of blasting powder
Destructive power	weak	Very strong and 6 times than that of blasting powder.
Efficiency	0.40 m ³	0.60 m ³
Use	Used for ordinary type of quarrying work	Used for tunneling and mining operations

PRECAUTIONS IN BLASTING:

- Blasting should not be carried out in late evening or early morning hours
- A siren should warn the work men and nearby public to maintain a safe distance.
- The danger zone, an area of about 200 mts radius should be marked with red flags.
- First aid should be available
- The number of charges exploded and the misfires should be recorded
- Explosives should be stored and handled carefully.
- Detonators and explosives should not be kept together

STORAGE OF EXPLOSIVES:

- The explosives should be stored in a magazine which should be away from residential areas, petrol depots.
- The magazine should have ventilators at high levels and should have concealed wiring.
- Magazine should be protected from lightning.
- Smoke or fire should not be allowed in the nearby area.
- Explosives should be protected from extreme heat or cold and also from moisture.

- The magazine should be surrounded by a barbed wire and the entry should be restricted.

PROPERTIES OF BUILDINGSTONES:

Various properties such as Porosity, Permeability Crushing Strength, Appearance, Durability; Coefficient of Hardness;

Specific gravity; Texture; Toughness Index; Water Absorption; Weathering; Density; Bulk Density; Density Index; Temperature Resistance etc., are to be properly studied before making final selection of any building material for a particular use.

Porosity (α): In simple terms, porosity may be described as the amount of openings (or) interstices (or)empty spaces present in a rock. However, Porosity may be defined as “the ratio of openings or pores or voids (V_i) in the soil/rock to the total volume of the soil / rock (V) expressed as percentage”. If α is the porosity, then $\alpha = V_i / V$ where V_i is the volume of interstices and V is the total volume. The average porosity values for some common geological formations are as follows:

Rock	Porosity	Rock	Porosity
Granite, Quartzite	1.5 %	Only Gravel	25%
Shale, Slate	4%	Only Sand	35%
Limestone	5-10 %	Only Clay	45%
Sand with gravel	20-30%		

Permeability:

The permeability of a rock or soil defines its ability to transmit a fluid or water. Permeability depends on the porosity and interconnected pores character of the rock, thus more porous rocks are more permeable too. (not always). Permeability in a rock is measured in *darcsies*($1\text{darcy} = 0.987 \mu m^2 \text{ square micrometer}$).

Eg: 1.Shales are highly porous but less permeable because of fine grained nature which does not allow water to pass through the rock due to less interconnected pores.

Crushing Strength:

For a good stone, the crushing strength should be greater than 100 Newton’s / mm^2 .

The approximate value of crushing strength of some of the stones is:

S No	Rock type	Building Stone	Crushing Strength N/mm ²)
1.	Igneous	Basalt	150 – 185
2.		Diorite	90–150
3.		Granite	75–127
4.		Kyenite	90–150
5.	Sedimentary	Limestone	54
6.		Sandstone	64
7.		Shale	0.20– 0.60
8	Metamorphic	Gneiss	206 – 370
9		Slate	75- 207

Appearance: The stones which are to be used for face work should be decent in appearance and capable of preserving their color uniformly for a long time. It is desirable to prefer light colored stones as compared to dark colored stones because there are chances of the latter variety to be attacked easily by weathering agents.

Durability: A good building stone should be durable. The various factors such as Chemical composition; Resistance to atmospheric conditions etc... influence the durability of a stone. Following are the important atmospheric agencies which affect the durability of a stone.

Co-efficient of Hardness: The co-efficient of hardness, as worked out in hardness test should be greater than 17 for a stone to be used in road work. If it is between 14 and 17, and < 14, the stone is said to be medium and poor hardness respectively and such stone should not be used in road works.

Specific gravity: For a good building stone, the specific gravity should be greater than 2.7 The heavy varieties of stones with more compact and less porous can be used for various engineering applications such as dams, weirs retaining walls, docks etc.. On the other hand, the lighter varieties of stones are to be used for domes, roof coverings etc.

Texture: A building stone should have compact, fine crystalline nature, free from cavities, cracks, loose material, softness etc.

Toughness Index: In impact test, if the value of toughness index comes below 13, the stone is not tough. If it comes between 13 and 19, the stone is said to be moderately tough. If it exceeds 19, the toughness of stone is said to be high.

Weathering: A building stone should be capable of withstanding adverse effects of various atmospheric and external agencies such as rain, frost, wind etc.

Density (ρ) is the mass of a unit volume of homogeneous material denoted by: $\rho = M / V$ (g/cm^3)
where

M = mass (g) and V = volume (cm^3).

Bulk density (ρ_b): Bulk density is the mass of a unit volume of material in its natural state (with calculated air spaces) $\rho_b = M / V$ (Kg/m^3)

where M = Mass of specimen (Kg) and

V = Volume of specimen in its natural state (m^3).

Density & Bulk density of some building materials are as follows:

Density Index (ρ_i) is the ratio between the bulk density and density i.e. $\rho_i = \rho_b / \rho$ Density index indicates the degree to which the volume of a material is filled

with solid matter. For almost all building materials ρ_i is less than 1.0 because there are no absolutely dense bodies in nature.

Material	Density (g/cm^3)	Bulk density (Kg/m^3)
Brick	2.5 – 2.8	1600 - 1800
Granite	2.6 – 2.9	2500 - 2700
Portland cement	2.9 – 3.1	
Wood	1.5 – 1.6	500 - 60
Steel	7.8 – 7.9	7850
Sand		1450 - 1650

In addition, Percentage wear, resistance to fire, dressing etc are also to be considered for a good building stone.

DRESSING OF A STONE: The stones, after being quarried, are to be cut into suitable sizes and this process is known as the dressing of stones. The dressing of stones is carried out for the following purposes:

- To obtain a definite and regular shape.
- To make the transport from quarry easy and economical.
- Provides pleasing appearance
- To suite to the requirements of stone masonry.
- At quarry site, it is possible to get cheap labour for the process of dressing of stones.

- It is possible to sort out stones for different works
- The irregular and rough portions of the stones are removed which decrease the weight of stones.

Following are the varieties of finishes obtained by the dressing of stones:

Dragged (or) Combed finish: In this type of finish, a piece of steel which is similar to a comb is rubbed on the surface in all directions and surface of the stone. This finish is suitable for soft stones only.

Punched finish: On the stone surface, the depressions are made by using a punch. The surface of the stone takes the form of a series of hollows and ridges.

Reticulated finish: This type of finish represents anet-like appearance.

A margin about 20 mm wide is marked on the edges of stone and irregular sinking's are made on the enclosed space. A pointed tool is used to put the marks on the sunk surface so as to present a pock – marked appearance.

Tooled finish: The stone surface is finished by means of a chisel and parallel continuous marks either horizontal or inclined or vertical are left on the surface.

Rock faced finish: Some stones, as obtained from the quarry, possess smooth surface and they can be directly placed on the work. Such a stone surface is termed as Rock – faced (or) quarry – faced finish.

Vermiculated finish: This finish is similar to reticulated type except that the sinking's are more curved.

ARTIFICIAL STONES: Where durable natural stone is not available at reasonable cost, artificial stone, also known as CAST STONE becomes the choice. Artificial stone is made with cement and natural aggregates (crushed stone) and sand with desired surface finish. Suitable color pigments may be added. Following procedure is generally adopted in making an artificial stone:

- A mixture of 1½ parts of stones of size 3–6 mm; 1½ parts of stones of size < 3mm and 1 part of cement by volume is prepared.
- The necessary pigment is added to produce the desired color effect to the above mixture.
- Required quantity of water is added and thorough mixing is done.
- The mixture thus prepared is transferred to special moulds.
- The mixture is allowed to harden and its surface is kept wet.
- The artificial stone is then ready in block form.
- Polishing can be done if required.

FORMS OF ARTIFICIAL STONES:

Cement Concrete: This is a mixture of cement, fine aggregate, coarse aggregate and water. If steel is used with cement concrete, it is known as the Reinforced Cement Concrete (RCC). Concrete blocks are used in construction of piers, steps, window sills etc.

Mosaic Tiles: The pre-cast concrete tiles with marble chips at top surface are known as the mosaic tiles.

Terrazzo: This is a mixture of marble chips and cement. It is used for bath rooms, residential buildings, temples etc...

Victoria Stones are granite pieces with the surfaces hardened by immersing in soda silicate for about two months.

Ransom Stones are prepared by mixing soda silicate with cement to provide decorative flooring. These are also known as chemical stones. These have compressive strength of about 32 N / mm^2 .

BRICKS:

The common brick is one of the oldest building material and it is extensively used at present as a leading material in construction because of its durability, strength, reliability, low cost, easy availability, easy to handle etc.. Bricks are used for building up exterior and interior walls, partitions, footings and other load bearing structures.

The Great Wall of China (210 BC) was built with bricks. The other examples of the use of bricks in early stage of civilization could be in Rome. A number of country farm houses still exist in Great Britain and profess to be the monuments of the excellent hand – made bricks.

A brick is rectangular in shape and of size that can be conveniently handled with one hand. Bricks may be made of burnt clay or mixture of sand and lime (or) of Portland cement concrete.

Size of a standard brick (modular brick) should be $19 \times 9 \times 9 \text{ cm}$. However, the bricks available in most part of the country still are $9'' \times 4 \frac{1}{2}'' \times 3''$ and are known as field bricks. Weight of such a brick is 3.0 kg.

An indent called **frog**, 1 – 2 cm deep is provided for 9 cm height bricks only. The purpose of providing frog is to form a key for holding the mortar and therefore, the bricks are laid with frogs on top. Frog is not provided in 4 cm high bricks.

COMPARISON OF BRICKSTONE AND STONWORK:

The brickwork is superior to the stone work in the following respects:

- At places where stones are not easily available but where there is plenty.
- The bricks resist various atmospheric effects better than stones.
- In case of brickwork, the mortar joints are thin and hence the structure becomes more durable.
- It is easy to construct connections and openings in case of brickwork than stonework.

CHARACTERISTICS OF GOOD BRICK: The essential requirements for building bricks are sufficient strength in crushing, regularity in size, and a pleasing appearance when exposed to view.

Size and shape: The bricks should have uniform in size, rectangular surfaces with parallel sides and sharp straight edges.

Color: The brick should have a uniform deep red (or) cherry colour as indicative of uniformity in chemical composition and thoroughness in the burning of the brick.

Texture and compactness: The surfaces should not be too smooth to cause slipping of mortar. The brick should have uniform texture and should not show fissures, holes etc..

Hardness and soundness: The brick should be so hard that when scratched by a finger nail no impression is made. When two bricks are struck together, a metallic sound should be produced.

Water Absorptions should not exceed 20% of its dry weight when kept immersed in water for 24 hours to 48 hours.

Crushing Strength should not be less than 10 N / mm². Brick earth should be free from stones, Kankars, Organic matter, salt petre etc..

COMPOSITION / INGREDIENTS OF GOOD BRICK EARTH:

For the preparation of bricks, clay is usually used. The clay used for brick making consists mainly of silica and alumina mixed in such a proportion that the clay becomes plastic when water is added to it. It also consists of small proportions of lime, iron, magnesium, sulphur etc.. The proportions of various ingredients and functions are as follows

Silica	50 – 60 %
Alumina	20 – 30 %
Calcium	10 %
Mg	< 1 %
Ferric Oxide	< 7 % < 20 %
Alkalis	< 10 %
SO ₃ ; H ₂ O	< 2 %

Silica: A good brick earth should contain about 50% to 60% of silica. The presence of silica constituent prevents cracking, shrinking in bricks thus imparts uniform shape to the bricks. Excess of silica makes the brick brittle and weak on burning. The durability of bricks depends on the proper proportion of silica in brick earth.

Alumina:

A good brick earth should contain about 20 to 30% of alumina. If alumina is present in excess, with inadequate quantity of sand the raw bricks shrink and it produces cracks during drying and burning and become too hard when burnt.

Lime (calcium) : A small quantity of lime not exceeding 10% is desirable in good brick earth. The excess of lime causes the brick to melt and hence its shape is lost and also results in splitting of bricks into pieces.

Magnesia if exceeds 1%, affects the color and makes the brick yellow. Excess of magnesia content leads to the decay of bricks.

Iron – oxide usually constitutes < 7%. If it exceeds 7%, the brick becomes dark blue. When excess of oxygen is available, the bricks become dark brown or black color on burning.

HARMFUL SUBSTANCES IN BRICK EARTH: Following are the ingredients which are undesirable in the brick earth:

LIME: When lime is present in lumps, it absorbs moisture, swells and causes disintegration of the bricks.

PEBBLES, GRAVELS: The presence of pebbles of any kind is undesirable in brick earth because it will not allow the clay to be mixed uniformly and thoroughly which will result in weak and porous bricks. Also the brick containing pebbles will not break regularly as desired.

ALKALIES: These are mainly in the form of soda and potash. When alkalies present in excess, the bricks become unsymmetrical / loose their shape. Further, the presence of excess alkalies content absorb moisture from the atmosphere.

Such moisture, when evaporated, leaves behind grey or white deposits on the wall surface and the appearance of the building as a whole is then seriously spoiled.

ORGANIC MATTER: The presence of organic matter in the brick earth, which is not burnt in case, the bricks become porous and the strength is reduced.

SULPHUR & CARBON: Sulphur is usually found in clay as the sulphates of Calcium (CaSO_4);magnesium (MgSO_4); Sodium (NaSO_4); Potassium (K_2SO_4) and iron sulphides (FeS_2). If, however, there is carbon in the clay and insufficient time is given during burning for proper oxidation of carbon and sulphur, the latter will cause the formation of a spongy, swollen structure in the brick.

MANUFACTURING OF BRICKS

In the process of manufacturing of bricks, the following four distinct operations are involved:

1. Preparation of clay / Brick earth
2. Moulding
3. Drying
4. Burning

1. PREPARATION OF CLAY / BRICK EARTH

Consists of the following operations:

- a) Un-soiling: The soil used for making building bricks should be processed and to be free from gravel, sand ($> 2 \text{ mm}$); lime and kankar particles, organic matter etc. About 200 mm of the top layer of the earth, normally containing stones, pebbles, gravels, plant roots etc is removed after clearing the trees and vegetation.
- b) Digging: The clay is then dug out from the ground and is spread on the ground. The height of heaps of clay on the ground is about 600 mm to 1200 mm. The digging operation should be done before rains.
- c) Weathering: The clay/soil is left in heaps and exposed to weather for atleast one month. The soil should be turned over at least twice and it should be ensured that the entire soil is wet throughout the period of weathering.

In order to keep it wet, water may be sprayed as often as necessary. The plasticity and strength of the clay are improved by exposing the clay to weather.

Addition of water to the soil at the dumps is necessary for easy mixing and workability. However, the excessive moisture content may affect the size and shape of the finished brick. The blending makes clay fit for the next stage of tempering.

e) Tempering: In the process of tempering, the clay is brought to a proper degree of hardness. The tempering should be done exhaustively to obtain homogeneous mass of clay of uniform character.



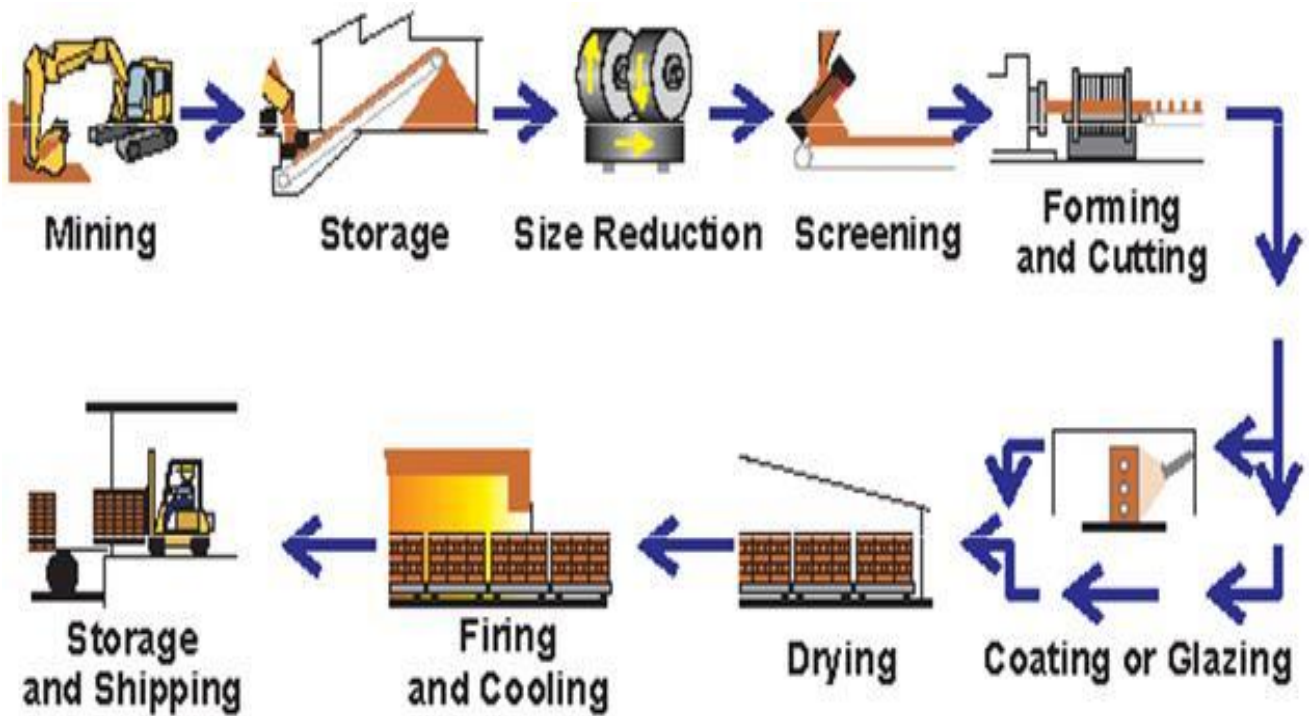

MANUFACTURE PROCESS OF BRICKS

MOULDING: It is a process of giving a required shape to the brick from the prepared clay / soil / brickearth. Moulding may be carried out by hand or by machines.

Hand Moulding: In this process, the bricks are moulded by hand ie manually. It is adopted where manpower is cheap and for producing a small quantity of bricks. A typical wooden mould should be prepared from well seasoned wood for making bricks.

The longer sides are kept slightly projecting to serve as handles. The strips of brass or steel are sometimes fixed on the edges of wooden moulds to make them more durable.

The steel mould even be prepared from steel angles and plates. The thickness of steel mould is generally 6 mm.

The bricks prepared by hand moulding are of two types:

- 1) Ground - moulded bricks
- 2) Table – moulded bricks

Ground – Mould bricks:

In this process, the ground is leveled and sand is sprinkled on it. The mould is dipped in water and placed over the ground. The clay is pressed or forced in the mould in such a way that it fills all the corners of the mould. The extra or surplus clay is removed with a sharp edged metal plate called STRIKE or with a thin wire stretched over the mould. After this process, the moulded bricks are left on the ground for drying.

The bricks prepared by dipping mould in water every time are known as the slop-moulded bricks. The fine sand or ash may be sprinkled on the inside surface of mould,, instead of dipping mould in water is known as Sand – Moulded bricks.

Table Moulding: the process of moulding these bricks is just similar to ground moulding. But in this process, the clay, mould, water pots, strikes, pallet boards are placed on the table. A thin board called palletis placed over the mould. The bricks are moulded on the table and sent for the further process of drying. The cost of brick moulding also increases slightly when table moulding is adopted.

Machine Moulding: The moulding may also be achieved by machines. It proves to be economical when bricks in huge quantity are to be manufactured at the same spot in a short time. Machine moulding can be done by either of the following process:

Plastic method (Plastic Clay Machine):The pugged clay is placed in the machine through a rectangular opening by means of an auger. Clay comes out of the opening in the form of a bar. The bricks are cut from the bar by a frame consisting of several wires at a distance of brick size and this is a quick and economical process. This process is also known as WIRE CUT BRICKS.

Dry Press Method / Dry Clay Method: In these machines, the strong clay is first converted into powder form. A small quantity of water is added to form a stiff plastic paste. Such paste is placed in mould and pressed by machine to form hard and well shaped bricks. These bricks are also known as PRESSED BRICKS. They can be sent directly for the next process of burning.

3.DRYING: For drying, the bricks are laid longitudinally in stacks. The bricks in stacks should be arranged in such a way that sufficient air space is left between them. The bricks should be allowed to dry till they become hard or the moisture content is brought down to about 3% under exposed conditions within 3 to 4 days.

For the drying purpose, Drying yards should be prepared. The Drying yards should be slightly on a higher level and it is desirable to cover it with sand. Such an arrangement would prevent the accumulation of rain water.

4. BURNING: This is a very important operation in the manufacture of bricks. The burning of clay may be divided into three main stages.

Dehydration stage (400 – 650°C): This is also known as *water smoking stage*.

During dehydration :

- The water which has been retained in the pores of the clay after drying is driven off;
- Some of the carbonaceous matter is burnt;
- Carbonated minerals are more or less de carbonated;
- Too rapid heating causes cracking or bursting of the bricks.

Oxidation period (650 – 900°C):

During the oxidation period, the remaining carbon is eliminated and the ferrous iron is oxidized to the ferric form. Removal of sulphur is completed only after the carbon has been eliminated.

Vitrification (upto 1100°C):

When the temperature is reached about 1100°C, the two important constituents viz., alumina and sand bind themselves together resulting in the increase of strength and density of bricks. If the temperature is raised beyond 1100°C, a great amount of fusible glassy mass is formed and the bricks are said to be vitrified. The bricks begin to lose their shape beyond a certain limit of vitrification. Burning of bricks is done in a *Clamp or Kiln*. A Clamp is a temporary structure whereas Kiln is a permanent one.

Burning in Clamps (Pazawah): A piece of ground with trapezoidal shape is selected. The alternate bricks and fuel are placed in layers. The fuel may consist of grass, cow dung, litter, husks of rice or ground nuts etc..

The thickness of this fuel layer is about 700 – 800 mm. The wood or coal dust may also be used as fuel.

Each brick tier consists of 4 – 5 layers of bricks. The total height of a clamp is about 3 – 4 mts. When the Clamp is completely constructed, it is plastered with mud on sides and top and filled with earth to prevent the escape of heat. The Clamp is allowed to burn for a period of about one to two months and then it is allowed to cool more or less of the same period as burning. The burnt bricks are then taken out from the clamp, and sides get cooled during reloading and are to be heated again during next firing, there is wastage of fuel. . They may be over ground or underground.

Fly ash Bricks: Fly ash bricks are masonry units that are used in the construction of buildings. They are considered to be a part of good and affordable building materials. They contain Class C fly ash and water.

Fly ash bricks are made by compressing Class C fly ash and water at 4000psi and then curing is carried on for 24 hours at a temperature of 66 degrees Celsius steam bath. Air entrainment agent is used to toughen the bricks.

GREEN BRICKS: The bricks are used like conventional clay bricks—for building things from houses to factories. They're called green because they are built from a toxic byproduct produced from coal-burning power plants. Instead of these toxins being released into the environment, or disposed of through costly means, they're pumped into the bricks.

The waste product is called fly ash. It's loaded with mercury, lead, and other toxic chemicals. Coal-burning power plants spend millions of dollars to dispose of the powdery byproduct. Until now, the estimated 70 million tons of byproduct has been buried in specially designed ponds and waste centers.

GREEN BRICKS

CONTINUOUS KILNS:

The process of burning bricks is continuous, and hence it is known as continuous kiln (eg: Bull's Trench Kiln and Hoffman's Kiln). In this process, bricks are stacked in various chambers wherein the bricks undergo different treatments at the same time. When the bricks in one of the chambers is fired, the bricks in the next set of chambers are dried and preheated while bricks in the other set of chambers are loaded and in the last are cooled.

TUNNEL KILN: A tunnel kiln useful for burning vertically perforated green bricks, includes a furnace chamber; tubular burners for heating the furnace chamber and a transport device for transporting green bricks in raster-like spaced-apart relationship in a travel direction through the furnace chamber that the perforations of the green bricks are oriented in a common direction.

TUNNEL KILN

In operation, new green bricks, along with roofing bricks, are stacked at one end of the brick pile; cooled finished bricks are removed from the other end for transport. In the middle, the brick

workers create a firing zone by dropping fuel (coal, wood, oil, debris, and so on.) through access holes in the roof above the trench.

The advantage of the BTK design is a much greater energy efficiency compared with clamp or scovekilns. Sheet metal or boards are used to route the airflow through the brick lattice so that fresh air flows first through the recently burned bricks, heating the air, then through the active burning zone. The air continues through the green brick zone (pre-heating and drying them), and finally out the chimney where the rising gases create suction which pulls air through the system. The reuse of heated air yields savings in fuel cost.

A half dozen laborers working around the clock can fire approximately 15,000-25,000 bricks a day. In the BTK process the bricks do not move. Instead, the locations at which the bricks are loaded, fired, and unloaded gradually rotate through the trench.

TESTS FOR BRICKS: A brick is generally subjected to the following tests to find out its suitability for the construction work:

Water Absorption Test (US 3495): A brick is taken and it is weighed dry. It is then immersed in water for a period of 24 to 48 hours. It is weighed again and the difference in weight indicates the amount of water absorbed by the brick. It should not, in any case, exceed 5%-20% of weight of dry brick.

Compressive Strength Test IS: 3495): The crushing strength of a brick is find out by placing in a compression testing machine. It is pressed till it breaks. The minimum crushing or compressive strength of bricks is 3.50 N / mm^2 .

Efflorescence Test: The brick is immersed in water for 24 hours. It is then taken out and allowed to dry in shade. The absence of grey or white deposits on its surface indicates the absence of soluble salts. If the white deposits cover about 10% surface, the efflorescence is said to be slight and it is considered as moderate when the white deposits cover about 50 % of surface. If grey or white deposits are found on more than 50 % of surface, the efflorescence becomes heavy and it is treated as serious.

Soundness: In this test, the two bricks are taken and they are struck with each other. The bricks should not break and a clear ringing sound should be produced.

DIFFERENT FORMS OF BRICKS: Various forms of bricks are used depending upon the places of use. For eg

Gun powder	A mixture of charcoal, salt petrel (KNO_3) and Sulphur and the proportions by weight are 15, 75 and 10 respectively.
Magazine	A special type of building meant for storing the explosives.
Masonry	Masonry may be defined as the construction of building units (such as stones bricks / precast blocks of concrete) bonded together with mortar.
Metamorphism	The process by which the changes are brought in solid rocks by the agencies of temperature, pressure and chemical active solutions which in turn establish an equilibrium.
Mortar	Mortar is a homogeneous mixture produced by uniform mixing of cement or lime or combination of these two in addition to sand and water to make a paste of required consistency.
Pallet	A thin board called <i>pallet</i> is placed over the mold
Pugging	the process of grinding clay with water and making it plastic is known as the Pugging.
Strike	The extra or surplus clay is removed with a sharp edged metal plate called <i>STRIKE</i>

Aggregates generally occupy 65- 80% of a concrete's volume. Aggregates are inert fillers floating in the cement paste matrix for concretes of low strength. The strength of aggregates do not contribute to the strength of concrete for low strength concrete. The characteristics of aggregates impact performance of fresh and hardened concrete.

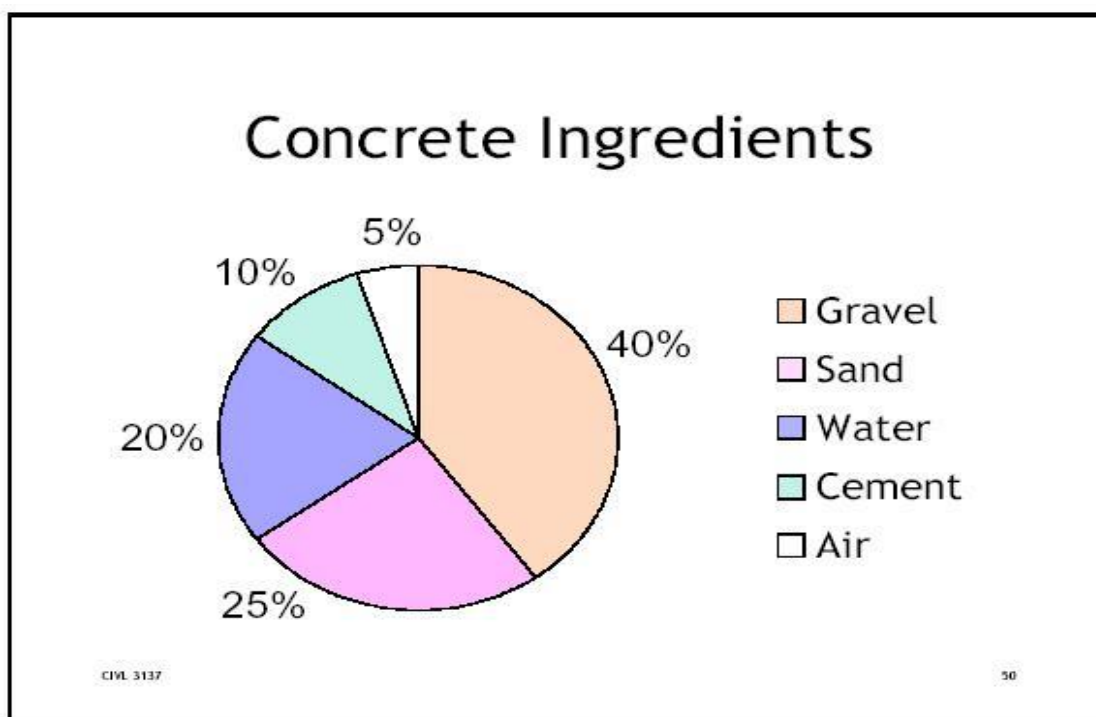

Why use aggregate:

- Reduce the cost of the concrete— 1/4 - 1/8 of the cement price
- Reduce thermal cracking— 100 kg of OPC produces about 12°C temperature rise
- Reduces shrinkage— 10% reduction in aggregate volume can double shrinkage
- High aggregate : cement ratio (A/C) desirable
- A/C mainly influenced by cement content
- Imparts unit weight to concrete

Aggregate Classification

Aggregates are classified as below:

Based on size:-F.A & C.A.

Specific Gravity: - Light Weight, Normal Weight and Heavy Weight Aggregates.

Availability: - Natural Gravel and Crushed Aggregates.

Shape:-Round, Cubical, Angular, Elongated and Flaky Aggregates.

Texture:-Smooth, Granular, Crystalline, honey combed and Porous.

There are two types of Aggregates used in concrete making based on their size:

- Coarse Aggregates.
- Fine Aggregates.

Fine Aggregate

- Sand and/or crushed stone.
- < 4.75 mm.
- F.A. content usually 35% to 45% by mass or volume of total aggregate. Coarse Aggregate
- Gravel and crushed stone.
- ≥ 4.75 mm.
- typically, between 9.5 and 37.5 mm.

Rock and Mineral Constituents in Aggregates

1. Minerals

- Silica Quartz, Opal
- Silicates Feldspar, Clay
- Carbonate
- Calcite, Dolomite Sulphate
- Sulphate
- Gypsum, Anhydrite
- Iron sulphide

- Pyrite, Marcasite
- Iron oxide
- Magnetite, Hematite

Igneous rocks

- Granite
- Syenite
- Diorite
- Gabbro
- Peridotite
- Pegmatite
- Volcanic glass
- Felsite
- Basalt

Sedimentary rocks

- Conglomerate
- Sandstone
- Clay stone, siltstone, argillite, and shale
- Carbonates

Metamorphic rocks

- Marble
- Meta quartzite
- Slate
- Phyllite
- Schist

Normal-Weight Aggregate

- Most common aggregates
- Sand
- Gravel

- Crushed stone
- Produce normal-weight concrete 2200 to 2400 kg/m³

Lightweight Aggregate

Expanded

- Shale
- Clay
- Slate
- Slag

Produce lightweight insulating concrete— 250 to 1450 kg/m³

Heavyweight Aggregate:

- Barite
- Limonite
- Magnetite
- Hematite
- Iron

Aggregate Characteristics

Grading of Aggregates

Grading is the particle-size distribution of an aggregate as determined by a sieve analysis using wire mesh sieves with square openings. As per IS:2386(Part-1)

Fine aggregate—6 standard sieves with openings from 150 μm to 4.75 mm.

Coarse aggregate—5 sieves with openings from 4.75mm to 80 mm.

Gradation (grain size analysis)

Grain size distribution for concrete mixes that will provide a dense strong mixture. Ensure that the voids between the larger particles are filled with medium particles. The remaining voids are filled with still smaller particles until the smallest voids are filled with a small amount of fines.

Ensure maximum density and strength using a maximum density curve

Good Gradation:

Concrete with good gradation will have fewer voids to be filled with cement paste (economical mix)

Concrete with good gradation will have fewer voids for water to permeate (durability)

Particle size distribution affects:

- 1) Workability
- 2) Mix proportioning

The percentage passing **600 μ m** sieve will decide the zone of the sand.

Zone-I Coarse Sand

Zone-II

Zone-III

Zone-IV Fine Sand

Grading Limits Can also be represented through a graph of sieve size on the x-axis and % passing on the Y-axis (Semi log sheet).

Fineness Modulus (FM):

The result of aggregate sieve analysis is expressed by a number called Fineness Modulus. Obtained by adding the sum of the cumulative percentages by mass of a sample aggregate retained on each of a specified series of sieves and dividing the sum by 100. The specified sieves are: 150 μ m (No. 100), 300 μ m (No. 50), 600 μ m (No. 30), 1.18 mm (No. 16), 2.36 mm (No. 8), 4.75 mm (No. 4), 9.5 mm , 19.0 mm , 37.5 mm , 75 mm , and 150 mm.

Index of fineness of an aggregate.

The fineness modulus of the fine aggregate is required for mix design since sand gradation has the largest effect on workability. A fine sand (low FM) has much higher effect paste requirements for good workability. The FM of the coarse aggregate is not required for mix design purposes.

It is computed by adding the cumulative percentages of aggregate retained on each of the specified series of sieves, and dividing the sum by 100 [smallest size sieve: No. 100 (150 μ m

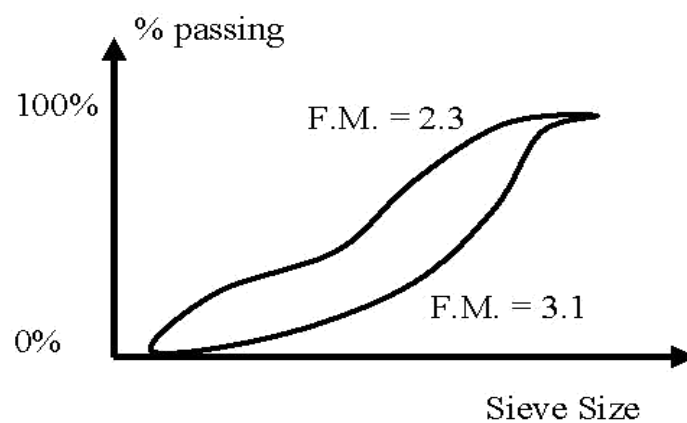

For concrete sand, FM range is 2.3 to 3.1

- Note: The higher the FM, the coarser the aggregate.
- It is important to note that the fineness modulus is just one number which only characterizes the average size of the aggregate, and different grading may have the same fineness modulus.

Fine Aggregate effect on concrete:

- Over sanded (More than required sand)
 - Over cohesive mix.
 - Water reducers may be less effective.
 - Air entrainment may be more effective.
- Under sanded (deficit of sand)
 - Prone to bleed and segregation.
 - May get high levels of water reduction.
 - Air entrainers may be less effective.

Reduction of Voids

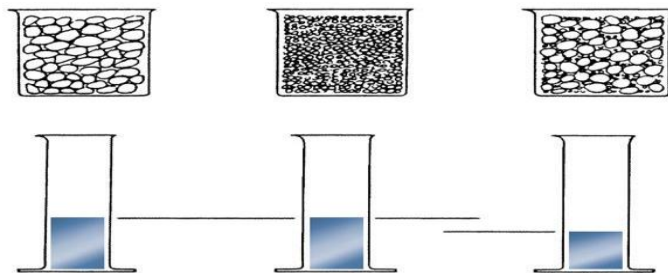

If uniform size aggregates are there there will be more voids as can be seen from the first two figures. If properly graded aggregates are used which contain suitable percentage of all size then the voids will be minimum which is explained in the figure.

Maximum Size vs. Nominal Maximum Size of Aggregate:

Maximum size — is the smallest sieve that all of a particular aggregate must pass through.

Nominal maximum size is the standard sieve opening immediately smaller than the smallest through which all of the aggregate must pass. The nominal maximum-size sieve may retain 5% to 15%

Nominal Maximum Size of Aggregate:

Size should not exceed

1/5 of the narrowest dimension between sides of forms.

3/4 clear spacing between re-bars and between re-bars and the form. 1/3 depth of slabs.

Higher maximum aggregate size lowers paste requirements, increases strength and reduces w/c ratio. Excessively large aggregates reduce strength due to reduced surface area for bonding. It affects the paste requirements, optimum grading depends on MSA and nominal max. size. The higher MSA, the lower the paste requirements for the mix. Aggregate size affects the following concrete properties: water demand, cement content, micro cracking (strength).

Effect of aggregate size on the surface area

size	# of particles	volume	surface area
1"	1	1 cubic inch	6 square inches
.5"	8	1 cubic inch	12 square inches
0.25	64	1 cubic inch	24 square inches
0.125	512	1 cubic inch	48 square inches

Larger particles, less surface area, thicker coating, easy sliding of particles. Smaller particles, more surface area, thinner coating, interlocking of particles.

Maximum Aggregate Size and Water Requirement:

Effect on water demand

Max size of	Slump	Slump
Aggregate	30 - 60 mm	60 - 180 mm
10 mm	230 kg/m ³	250 kg/m ³
20 mm	210 kg/m ³	225 kg/m ³
40 mm	190 kg/m ³	205 kg/m ³
Max size of	Water content	A:C ratio

Aggregate		
10 mm	230 kg/m ³	4.7
20 mm	210 kg/m ³	5.3
40 mm	190 kg/m ³	6.0

- General the grading and maximum size of aggregate affect the following:
- Relative aggregate proportions (i.e. FA/CA and FA/TA ratios)
- Cement and water requirements
- Workability and pump ability of fresh concrete: very coarse sands and coarse aggregate can produce harsh, unworkable mixes
- Uniformity of concrete from batch to batch
- Porosity, shrinkage, and durability of hardened concrete
- Economy in concrete production: very fine sands are often uneconomical

Moisture In Aggregates:

Aggregates have two types of moisture:

- Absorbed moisture – retained in pores
 - Surface moisture – water attached to surface
- Aggregates have four moisture states:

Oven dry: all moisture removed

Air dry: internal pores partially full & surface dry

Saturated-surface dry: pores full & surface moisture removed

Wet: pores full and surface film

SSD aggregate does not add or subtract water

Not easily obtained in the field

Moisture Absorption:

We must determine how much water dry aggregate will consume into its voids

This takes water away from the mix and reduces workability & W/C ratio

We adjust mix proportions for absorption

We want to: provide aggregates water for absorption maintain workability of the mix

Shape and surface texture of aggregates:

The shape of aggregate is an important characteristic since it affects the workability of concrete. It is difficult to measure the shape of irregular shaped aggregates. Not only the type of parent rock but also the type of crusher used also affects the shape of the aggregate produced. Good Granite rocks found near Bangalore will yield cuboidal aggregates. Many rocks contain planes of jointing which is characteristics of its formation and hence tend to yield more flaky aggregates. The shape of the aggregates produced is also dependent on type of crusher and the reduction ratio of the crusher. Quartzite which does not possess cleavage planes tend to produce cubical shape aggregates. From the standpoint of economy in cement requirement for a given water cement ratio rounded aggregates are preferable to angular aggregates. On the other hand, the additional cement required for angular aggregates is offset to some extent by the higher strengths and some times greater durability as a result of greater Interlocking texture of the hardened concrete. Flat particles in concrete will have objectionable influence on the workability of concrete, cement requirement, strength and durability. In general excessively flaky aggregates make poor concrete. while discussing the shape of the aggregates, the texture of the aggregate also enters the discussion because of its close association with the shape. Generally round aggregates are smooth textured and angular aggregates are rough textured. Therefore some engineers argue against round aggregates from the point of bond strength between aggregates and cement. But the angular aggregates are superior to rounded aggregates from the following two points:

Angular aggregates exhibit a better interlocking effect in concrete, which property makes it superior in concrete used for road and pavements. The total surface area of rough textured angular aggregate is more than smooth rounded aggregates for the given volume. By having greater surface area, the angular aggregates may show higher bond strength than rounded aggregates. The shape of the aggregates becomes all the more important in case of high strength and high performance concrete where very low water/cement ratio is required to be used . In such cases cubical aggregates are required for better workability.

Surface texture is the property, the measure of which depends upon the relative degree to which particle surface are polished or dull, smooth or rough. Surface texture depends upon hardness, grain size, pore structure, structure of the rock and the degree to which the forces acting on it have smoothed the surface or roughened. Experience and laboratory experiments have shown that the adhesion between cement paste and the aggregate is influenced by several complex factors in

addition to the physical and mechanical properties. As surface smoothness increases, contact area decreases, hence a highly polished particle will have less bonding area with the matrix than a rough particle of the same volume. A smooth particle, however, will require a thinner layer of paste to lubricate its movements with respect to another aggregate particle. It will therefore permit denser packing because of enhanced workability.

Aggregate: Shape and Surface Texture:

Ideal aggregates: spherical or cubical round shape, fine porous surface reduced particle interaction (friction) results in good workability and good surface area for bonding natural sands are good examples of this

Non Ideal aggregates:

Angular elongated flaky or rough high particle interaction requires more cement paste to achieve workability results in increased cost

Rounded: Good workability, low water demand, poor bond

Irregular: Fair workability, low water demand

Angular: Increased water demand, good bond

Elongated : May lack cohesion and require increased fines

Flaky: Aggregate stacks give workability problems

Coarse Aggregate Texture:

- Glassy.
- Smooth.
- Granular.
- Crystalline

Honeycombed and porous:

- Depends on: rock hardness, grain size, porosity, previous exposure.
- Aggregate shape and texture affect the workability of fresh concrete through their influence on cement paste requirements.
- Sufficient paste is required to coat the aggregates and to provide lubrication to decrease interactions between aggregate particles during mixing.

Rounded: Good workability, low water demand, poor bond

Irregular: Fair workability, low water demand

Angular: Increased water demand, good bond

Elongated : May lack cohesion and require increased fines

Flaky: Aggregate stacks give workability problems

Coarse Aggregate Texture:

- Glassy.
- Smooth.
- Granular.
- Crystalline
- Honeycombed and porous.

UNIT- 2

CEMENT & ADMIXTURES

Babylonians were perhaps the first to use clay as cementing material. In ancient times stones have been invariably used as a construction material with lime as the binder for construction of forts and defense structures. Egyptians have used lime and gypsum as cementing materials in the famous Pyramids. The calcareous rocks used by the Romans were either composed of limestone's burned in Kilns or mixtures of limestone and puzzolanic materials (volcanic ash, tuff) combining into a hard concrete. The natural cement is obtained by burning and crushing the stones containing clay, carbonate of lime (CaCO_3) and a little quantity of magnesia (CaMgCO_3)₂. The natural cement is brown in color and is also known as Roman cement.

Ingredient	Oxide / composition	%	Range	Function
Lime	CaO	62	60 – 65	Controls strength and soundness. Its deficiency reduces strength & setting time
Silica	SiO_2	22	17 – 25	Imparts strength. Excess cause slow setting
Alumina	Al_2O_3	5	3 – 8	Responsible for quick setting, if in excess it lowers the strength / weakness the cement
Calcium sulphate	CaSO_4	4	3 – 4	A small amount of sulphur is useful in making sound cement. If it is in excess , it causes cement to become unsound.
Iron oxide	Fe_2O_3	3	0.5 – 6	Gives colour, hardness & strength to the cement
Magnesia	MgO	2	0.5 – 4	Gives color, hardness. If in excess, it causes cracks in mortar.
Alkalies	$(\text{Na}_2\text{O} + \text{K}_2\text{O})$	1	0.1 – 0.4	These are residues and if in excess cause efflorescence and cracking

USES OF CEMENT: Cement is widely used in construction of various engineering structures.

Following are various possible uses of cement:

- Cement mortar for masonry works
- Cement Concrete for laying floors, roofs, lintels, beams, stairs, pillars etc
- Construction of important engineering structures such as Bridges, Culverts, Dams, Tunnels, storage Reservoirs; Docks etc
- Making Cement Pipes
- Manufacture of precast pipes, dust bins, fencing posts etc..

S.No	Physical requirement	Grade		
		33	43	53
1	Fineness (m ² /Kg)	225	225	225
2	Soundness	10mm	10mm	10mm
3	Setting time (minimum)	30 minutes	30	30
	Setting time (maximum)	600 minutes	600	600
4	Compressive Strength (MPa)/n/mm ²			
5	72 hours (3 days)	16	23	27
6	168 hours (7 days)	22	33	37
7	672 hours (28 days)	33	43	53

MANUFACTURE OF CEMENT: Calcareous (limestone, marl, chalk, marine shell) and argillaceous (clay, shale, slate etc) materials are used in the manufacture of Ordinary or Portland cement. From these materials, like silica, iron-oxide, and small quantities of other chemicals such as Na, K, S are obtained during the process of manufacturing of cement. Cement can be manufactured either by dry process or wet process.

DRY PROCESS (Modern Technology) : This process is adopted when the raw materials are quite hard. The raw materials of limestone and clay are first reduced in size of about 25 mm in crushers. A dry air is then passed over these materials. These dried materials are then pulverized into fine powder separately in the ball mills.

Ball mill is a key equipment to grind the crushed materials, and the ball mill is widely used in powder-making production. All these materials are stored in hoppers / bins / silos and they are then mixed in correct proportions.

The clinker is cooled rapidly to preserve the metastable compounds and then ground in Tube Mills where 2 – 3 % of gypsum is added. The purpose of adding gypsum is to retard the setting of cement. Generally, cement is stored in bags of 50 kg. The dry process has been modernized and it is widely used at present because of competition in production; lesser consumption of power; automatic proper temperature; aent of instrumentation; computerization and quality

Flow diagram of manufacturing of cement

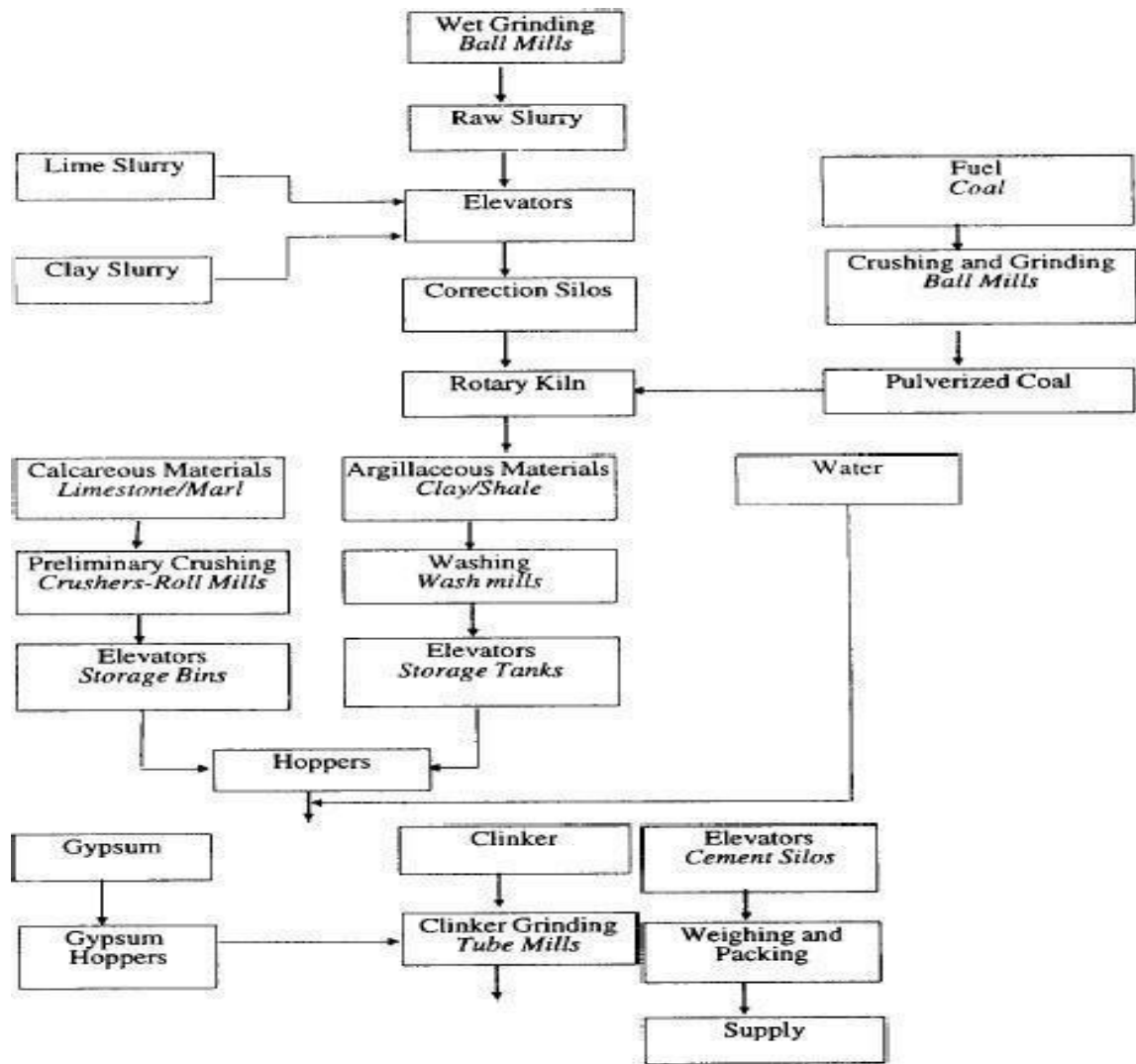

WET PROCESS (old technology) Wet process was used for the manufacture of cement started from 1913 onwards and till early 1980. The operations involved in the wet process of cement manufacture are mixing; burning and grinding.

The crushed raw materials are fed into ball mill and a little water is added to make thick paste. This paste, usually contain about 14% of moisture is dried and made ready for the feed of rotary kiln where it loses moisture and forms into lumps or nodules.. These are finally burned at 1500 – 1600°C where the nodules change to clinker at this temperature. Clinker is cooled and then ground in tube mills. While grinding the clinker, about 3% of gypsum is added. The cement is then stored in silos from where it is supplied. During the operation of ball mill; the steel balls in it pulverize the raw materials which form a slurry with water. This slurry is passed to silos (storage tanks), where the proportioning of the compounds is adjusted to ensure desired chemical composition.

Why gypsum is to be added during the manufacture of cement?

The gypsum is the hydrated sulphate of calcium and its chemical composition is $\text{CaSO}_4 \cdot 2\text{H}_2\text{O}$. It contains 79.1% calcium sulphate and 20.9% water. When gypsum is added to 205°C , its specific gravity increases from 2.3 to 2.95 due to loss of water. As a binding material, the gypsum quickly sets and hardens. It is soluble in HCl but insoluble in H_2SO_4 .

Gypsum has a number of valuable properties like bulk density, incombustibility, good absorbing capacity, good fire resistance, rapid drying etc. Because of all these properties, gypsum is used in the manufacture of cement to increase its setting time.

PLASTER OF PARIS: Plaster of Paris is a calcium sulfate hemi-hydrate ($\text{CaSO}_4 \cdot \frac{1}{2} \text{H}_2\text{O}$) derived from gypsum by firing this mineral at relatively low temperature of $160 - 170^\circ\text{C}$ and then reducing it to powder. In ancient times, in Paris, all the walls of wooden houses were covered with plaster as protection against fire. Since then the plaster was named as Plaster of Paris.

POP powder is mixed with water to form a paste which releases heat and then hardens once dried under normal temperature. Unlike mortar and cement, plaster remains quite soft after drying, and can be easily rubbed or scratched with metal tools or even sandpaper. On heating, further upto a temperature of about 20°C , the entire water is driven off and the resulting product is known as the Gypsum Anhydrite.

FIELD TESTS & LAB TESTS FOR CEMENT: In engineering construction, the main qualifications of a cement are permanency of structure; strength and a rate of setting. To determine these qualifications, both physical and chemical tests are made, the former on account of importance more often than the other. However, following field tests are to be carried out to ascertain the quality of cement:

The cement should feel smooth when touched in between fingers.

- If it is felt rough, it indicates adulteration with sand.
- If hand is inserted in a bag of cement, one should feel cool and not warm.
- If a small quantity of cement is thrown in a bucket of water, it should sink and should not float on the surface.
- The color of cement should be uniform and the typical cement color is grey.
- The cement should be free from any hard lumps. Such lumps are formed by the absorption of moisture from the atmosphere.

As a result of long experience the physical tests which have come into general use in determining the acceptability of cement are:

- Soundness
- Strength:
- Consistency Test and
- Fineness.

SOUNDNESS: Soundness refers to the ability of a hardened cement paste to retain its volume after setting without delayed destructive expansion. This destructive expansion is caused by excessive amount of CaO or MgO. In other words, the purpose of this test is to detect the presence of uncombined lime in cement. This may happen due to over burning of ingredients of cement in kilns. So it is an important test to assure the quality of cement since an unsound cement produces cracks, disintegration and leading to failure finally.

Soundness of cement may be tested by *Le-Chatelier* method or by *autoclave* method.

STRENGTH: Cement is tested for Compressive and Tensile strength because the cement hydrates when water is added to it. So, the strength of mortar and concrete depends upon the type and nature of cement.

Hydration of cement: The chemical reaction between cement and water is known as hydration of cement

Conditions affecting strength:

- Cement is very strong at early stages if a high lime or high alumina content is present.
- Gypsum and Plaster of Paris in small percentages also tend to increase the strength slightly but when present in quantities more than 3%, these substances provide variable effects.
- The strength of cement is greatly also influenced by the degree of burning, the fineness of grinding.
- An under burnt cement is likely to be deficient in strength.

Compressive Strength.: Compressive Strength is the basic data required for mix design. By this test, the quality and quantity of concrete can be controlled and the degree of **adulteration** is checked.

The compressive strength at the end of 3 days, 7 days and 28 days are given in table and the results are expressed in N/mm^2

Tensile Strength: Tensile Strength may be determined by Briquette Test method or by Split Tensile Strength Test. The Tensile strength of cement affords quicker indications of defects in the cement. However, the test is also used for the determination of rapid hardening cement. The tensile strength at the end of 3 days and 7 days for OPC is 2.0 N/mm^2 and 2.5 N/mm^2 respectively.

($2.0 \text{ N/mm}^2 = 20 \text{ kg/cm}^2$) ($2.5 \text{ N/mm}^2 = 25 \text{ Kg/cm}^2$)

consistency Test: This is a test to estimate the quantity of mixing water to form a paste of normal consistency.

Vicat apparatus is used to determine the consistency test. 300 gms of cement is mixed with 25% water. The paste is filled in the mould of Vicat's apparatus and the surface of the filled paste is smoothed and leveled. A square needle 10 mm x 10 mm attached to the plunger is then lowered gently over the cement paste surface and is released quickly. The plunger pierces the cement paste. The reading on the attached scale is recorded. When the reading is 5 – 7 mm from the bottom of the mould, the amount of water added is considered to be the correct percentage of water for normal consistency

FINENESS: This test is carried out to check proper grinding of cement. In other words, the degree of fineness of cement is the measure of the mean size of the grains in it.

There are 3 methods for testing fineness:

- The Sieve method -- using 90 micron sieve
- The air permeability method (Lea Nurse and Blains method)
- The sedimentation method (Wagner Turbidimetre)

SIEVE METHOD: 100 gms of cement sample is taken and air set lumps if any, in the sample are broken with fingers. The sample is placed on a 90 micron sieve and continuously sieved for 15 minutes. The residue should not exceed the limits specified below:

Air Permeability method: In this process, a cement sample of 20 mm height is placed in the Lea and Nurse apparatus and air pressure is applied. A manometer is connected to the top and bottom of the permeability apparatus and the pressure is so adjusted

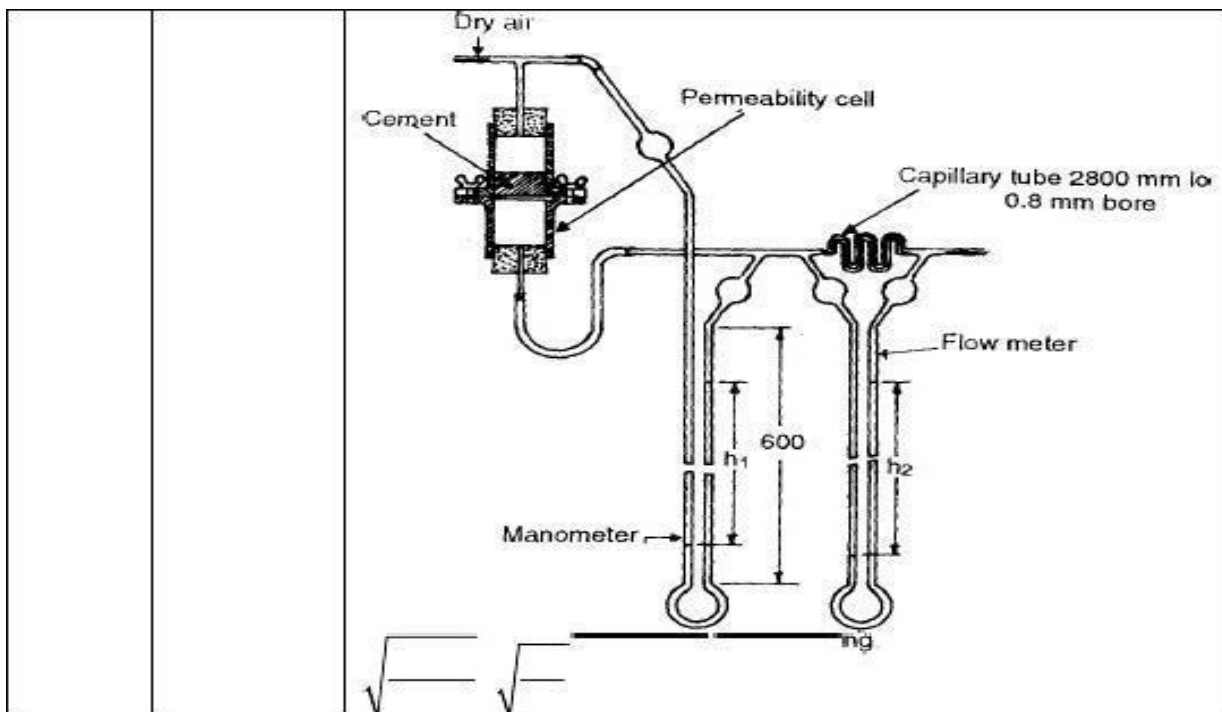

Wagner Turbidimeter method: This method is to be adopted to estimate the surface area of one gram of cement. The cement is dispersed uniformly in a rectangular glass tank filled with kerosene. Then, parallel light rays are passed through the solution which strike the sensitivity plate of photoelectric cell. The turbidity of the solution at a given instant is measured by taking readings of the current generated by the cell. By recording the readings at regular intervals while the particles are falling in the solution, it is possible to secure information regarding the grading in surface area and in size of particle. Readings are expressed in sq cm per gms.

ADMIXTURES: Admixture is defined as a material, other than water, aggregates, cement, that is added to the concrete immediately before or during mixing. Admixtures change properties of the concrete in colour, curing time, temperature range and setting time.

Concrete is being used for wide varieties of purposes to make it suitable in different conditions. Ordinary concrete may fail to exhibit the required quality performance or durability under different conditions. In such cases, admixture is used to modify the properties of ordinary concrete so as to make it more suitable for any situation.

Classification of admixtures as given by MR Rixom is:

- Plasticizers (Water Reducers)
- Super plasticizers (High Range Water Reducers)
- Retarders
- Accelerators
- Air entraining Admixtures
- Mineral Admixtures / Pozzolanic Admixtures
- Chemical Admixtures

Plasticizers and Super plasticizers specifically developed in Japan and Germany around 1950 and later on they were made popular in USA, Europe and Middle East. Unfortunately, the use of plasticizers and Super plasticizers have not become popular in India till recently (1985).

Plasticizers (Water Reducers): Concrete in different situations requires different degree of workability. A high degree of workability is required in case of beams, columns, beam junctions, pumping of concrete for considerable distances. One must remember that addition of excess water, will only improve the fluidity or the consistency but not the workability of concrete.

The easy method generally followed at the site in most of the conditions is to use extra water to overcome different situations which is an engineering practice. Today, the use of plasticizers helps the difficult conditions obtaining higher workability without using excess of water.

Super plasticizers (High Range Water Reducers): Super plasticizers constitute a relatively new category and improved version of plasticizer, the use of which was developed in Japan and Germany during 1960 and 1970 respectively.

Use of Super plasticizers permits the reduction of water to the extent up to 30% without reducing the workability. The use of super plasticizer is practiced for the production of high strength and high performance concrete. Super plasticizers can produce same w/c (water cement ratio); same workability; increased strength, homogeneous character etc.

Retarders: A retarder is an admixture that slows down the chemical process of hydration so that concrete remains plasticity and workable for a longer time. The retarders are used in casting purposes. These are also used in grouting oil wells. Oil wells are sometimes taken upto a depth of about 6000 meter deep where the temperature may be about 200°C. The spacing between the steel tube and the wall of the well are to be sealed with cement grout and to prevent the entry of gas or oil into other rock formations. For all these works cement grout is required to be in mobile condition for about 3 to 4 hours even at that high temperature without getting set.

Accelerators: These admixtures are added to increase the rate of strength of concrete and to reduce there required period of curing. In the past one of the commonly used materials as an accelerator was calcium chloride. The recent studies have shown that calcium chloride is harmful for reinforce concrete.

Air entraining Admixtures: Air entrained concrete is made by mixing a small quantity of air entraining agents. These agents modify the properties of concrete regarding workability, segregation, finishing quality of concrete. Air entraining admixture is used to prevent frost scaling in concrete.

The following types of air entraining agents are used for making concrete:

- Natural wood resins
- Animal or vegetable fats and oils such as olive oil, stearic acid; oleic acid.
- Various wetting agents such as alkali salts
- Miscellaneous materials such as the sodium salts of petroleum sulphonic acids, hydrogen peroxide and aluminium powder

The common air entraining agents are Vinsol resin, Darex, Airalon, Orvus, Teepol, Petrosan, Cheecoletc.. Air entrained nconcrete was used in the construction of Hirakud dam, Koyna dam, etc.

Chemical admixtures: Chemical admixtures are added to concrete in very small amounts mainly for reduction of water content or control of setting time.

Mineral admixtures: Mineral admixtures (puzzolanic materials) are usually added to concrete in larger amounts to enhance the workability of fresh concrete; to improve resistance of concrete.

The term Puzzolana is derived from Pozzuoli, a town in Italy. The sand (volcanic dust) around this town, when mixed with hydrated lime was found to possess cementitious properties. Puzzolanic materials can be divided into two groups such as:

Natural Puzzolanas viz clay, shales, cherts, volcanic tuff which needs further grinding and sometimes needs calcining to activate them to show puzzolanic properties. Artificial Puzzolanas include Fly ash, Blast Furnace Slag, Silica fumes.

USES: A proper use of admixtures offers certain beneficial effects to concrete, including improved quality, acceleration or retardation of setting time, enhanced frost and sulfate resistance, control of strength development, improved workability, and enhanced finish ability.

Blast Furnace Slag consisting essentially of silicates and aluminates of calcium. The granulated material when further ground to less than 45 microns will have specific surface of about 400-600 m²/kg. The chemical con of BFS is similar to that of cement clinker.

UNIT- III

BUILDING COMPONENTS AND FOUNDATIONS

LINTELS and ARCHES: Openings are invariably left in the wall for the provision of doors, windows, cupboards, almirahs etc... These openings are bridged by the provision of either a lintel or an arch. Thus, both lintel as well as arch are structural members designed to support the loads..

A lintel is a sort of beam, which is placed across the opening. The width of a lintel is equal to the width of the wall and the ends of which are built into the wall. Lintels are simple and easy to construct. Lintels are classified into the following types according to the materials of the construction:

Timber Lintels: These are relatively costlier, structurally weak and vulnerable to fire. Sometimes timber lintels are strengthened by the provision of mild steel plates at their top and bottom, such lintels are called *Flitched Lintels*.

Stone Lintels: These are common in usage where stone is abundantly available. Dressed stone lintels give good architectural appearance. Stone is very weak in tension and cracks develop if subjected to vibratory loads.

Brick Lintels: These are not structurally strong and they are used only when the opening is small and loads are light.

Steel Lintels: These are provided where the opening is large and the loads are heavy. It consists of steel channels either used singly or in combination of two or three units.

Reinforced Cement Concrete Lintels: Because of their strength, rigidity, fire resistance, economy and ease of construction, the RCC lintels are widely used. These can be used on any span. It is kept equal to the width of the wall. RCC lintels are also available as precast units.

Arches appeared as early as the 2nd millennium BC in Mesopotamian brick architecture and their systematic use started with the Ancient Romans who were the first to apply the technique to a wide range of structures.

An arch is an opening to support the weight of the wall or a load above it along with other superimposed loads. A structure, especially one of masonry, forming the curved (an inverted U) pointed, or flat upper edge of an open space and supporting the weight above it, as in a bridge or doorway. However, arches are constructed where

1. Loads are heavy
2. Span is more
3. Strong abutment is available

Special architectural appearance is required.

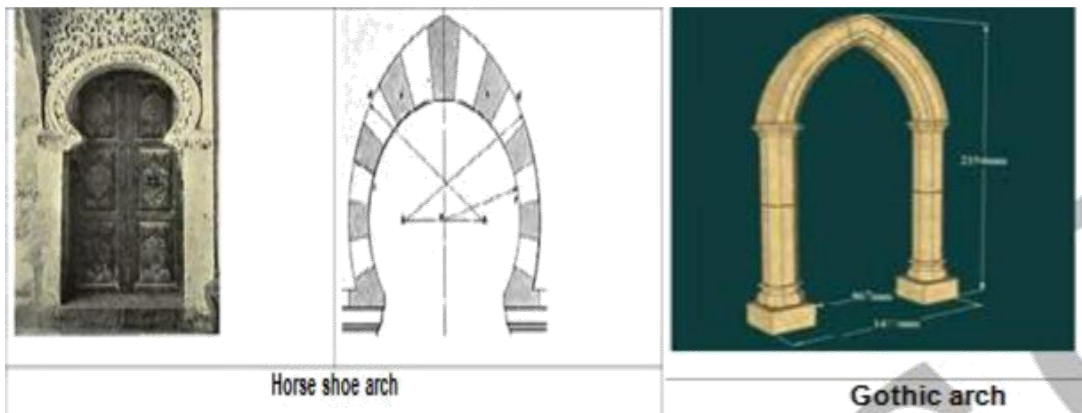

Classification of Arches: An arch can be classified as

- According to Shape
- Based on Number of Centers
- Based on material and workmanship

Classification according to shape:

Flat Arch: A flat arch has usually the angle formed by skewbacks as 60° , thus forming an equilateral triangle with intrados as the base. The extrados is kept horizontal & flat. Flat arches are used for light loads and for spans up to 1.5 mts.

Segmental Arch: The centre of arch lies below the springing line or lies on the springing line.

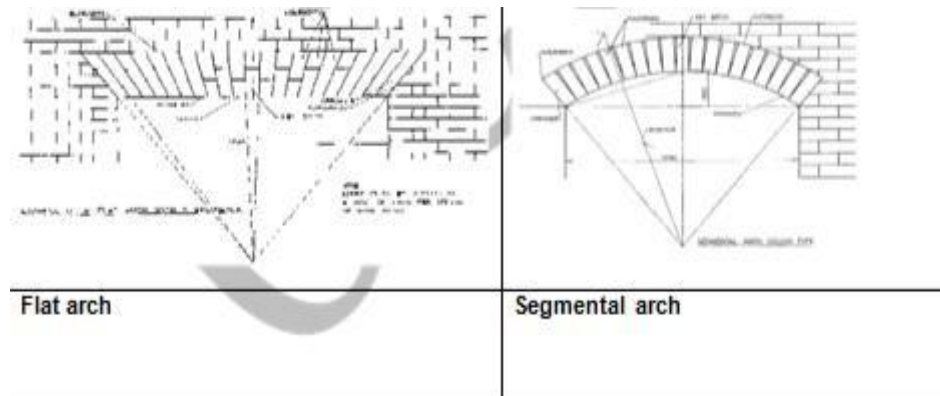

Horse shoe arch: The arch has the shape of a horse shoe, which is more than a semi-circle. Such type of arch is provided mainly from architectural considerations

Pointed arch: It consists of two arcs of circles meeting at the apex. The triangle formed may be either equilateral (all sides equal ie $ab = bc = ca$) which is also known as **GOTHIC arch** or isosceles (any two sides equal ie $ab=bc$ or $bc=ca$ or $ca=ab$) which is also called as **LANCE Tarch**.

Venetian arch: This is another form of pointed arch which has deeper depth at crown. It has four centers, all located on the springing line.

Foundations:

Definition:

The low artificially built part of a structure which transmits the load of the structure to the ground is called foundation.

A foundation (also called a ground sill) is a structure that transfers loads to the earth.

Concept:

Foundation of a structure is always constructed below the ground level so as to increase the lateral stability of the structure. It includes the portion of the structure below the ground level and is built, so as to provide a firm and level surface for transmitting the load of the structure on a large area of the soil lying underneath. The solid ground on which the foundation rests is called the Foundation Bed.

Purpose of Foundation:

All engineering structures are provided with foundations at the base to fulfill the following objectives and purposes;

- i. To distribute the load of the structure over a large bearing area so as to bring intensity of loading within the safe bearing capacity of the soil lying underneath.
- ii. To load the bearing surface at a uniform rate so as to prevent unequal settlement.
- iii. To prevent the lateral movement of the supporting material.
- iv. To secure a level and firm bed for building operations.
- v. To increase the stability of the structure as a whole.

Types Of Foundations

Foundations are broadly classified into two categories.

1) Shallow Foundations

- i. Spread footing or open trench foundations
- ii. Grillage foundations
- iii. Raft foundations
- iv. Stepped foundations
- v. Inverted arch foundations

2) Deep Foundations

- i. Pile foundations
- ii. Well foundations
- iii. Caisson foundations

UNIT –IV

WOOD, ALUMINIUM AND GLASS

Wood is a hard fibrous substance which forms a major part of the trunk and branches of a tree. Trees are classified as endogenous and exogenous according to the mode of growth: Classification and methods of sawing timber

Wood has many advantages due to which it is preferred for building material. Teak is not suitable for making construction of bridge works whereas Babool, Sal etc are suitable for making construction of bridges. Babool tree is also used for making agricultural implements. Ben teak is used for making boats while Deodar trees are meant for making railway sleepers. Jack trees are used for making musical instruments. Wood is easily available and easy to transport and handle. Wood is a good absorber of shocks and so is suitable for construction works. Wood can be easily repaired and alterations to wood work can also be done easily. Owing to the above mentioned advantages, wood is very widely used in buildings as doors, windows, frames, temporary partition walls etc

Classification of timber:

Wood suitable for building or other engineering works is called timber

When it forms a part of a living tree, it is called standing timber. When the tree has been felled, it is called rough timber. When it has been sawn to various market forms such as beams, battens, planks etc, it is called converted timber

Classification of Trees

Trees can be divided into the following groups

Endogenous

Exogenous

These are explained as below:

ENDOGENOUS:

Trees which grows inward in a longitudinal fibrous mass, such as canes, bamboo, palms etc

EXOGENOUS:

Trees which grows outward from the centre in approximate concentric rings across the longitudinal section of the stem. Each ring representing a layer deposited every year. Extensively used in engineering works. Exogenous trees are further divided into

1) Conifer:

Evergreen tree yielding softwood Trees with pointed leaves Pine, Chirr

B-2) Deciduous:

Trees with broad leaves yielding hardwood

Shed their leaves in winter (Sal, Sheesham etc)

1) Methods of sawing timber

2) methods of sawing timber

ORDINARY SAWN OR FLAT SAWN

Parallel cuts made throughout the length of the log Cutting parallel slices of planks Easiest and economical method Shrinkage of sapwood more than the heartwood Causing warp and twisting of planks.

QUARTER SAWING

Tendency to cup i.e. to curve in a transverse direction When applied to wood, not having distinct medullar rays this method produces very fine wood RIFT OR RADIAL SAWING Flat Sawn, Rift Sawn, Quarter Sawn Timber cut parallel to medullar rays and perpendicular to annual rings least shrinkage but most wasted limited rift is adopted

Greater decorative effect ► medullar rays pronounced

Properties of Wood & Timber

Wood is the oldest material used by humans for construction after stone. Despite its complex chemical nature, wood has excellent properties which lend themselves to human use. It is readily and economically available; easily machinable; amenable to fabrication into an infinite variety of sizes and shapes using simple on-site building techniques;

- Exceptionally strong relative to its weight
- A good heat and electrical insulator;
- of increasing importance
- It is a renewable and biodegradable resource.

However, it also has some drawbacks of which the user must be aware. It is a “natural” material and is available in limited amount properties of wood make it good for use in construction. Classification of

Timber Sawing Methods

Specific Gravity (SG):

Generally, specific gravity (SG) and the major strength properties of wood are directly related. SG for the major , usually used structural species ranges from roughly 0.30 to 0.90. Higher allowable design values are assigned to those pieces having narrower growth rings (more rings per inch) or more dense latewood per growth ring and, hence, higher SG.

Moisture Content (MC) and Shrinkage:

Undoubtedly, wood's reaction to moisture provides more problems than any other factor in its use. Wood is hygroscopic ; that is, it picks up or gives off moisture to equalize with the relative humidity and temperature in the atmosphere. As it does so, it changes in strength; bending strength can increase by about 50% in going from green to a moisture content (MC) found in wood members in a residential structure, for example. Wood also shrinks as it dries, or swells as it picks up moisture, with concomitant warpage potential. Critical in this process is the fiber saturation point (fsp) , the point (about 25% moisture content, on oven-dry basis) below which the hollow center of the cell has lost its fluid contents, the cell walls begin to dry and shrink, and wood strength begins to increase. The swelling and shrinkage processes are reversible and approximately linear between fiber saturation point and 0% MC.

Wood decay or fungal stain do not occur when the MC is below 20%. There is no practical way to prevent moisture change in wood; most wood finishes and coatings only slow the process down. Thus, vapor barriers, adequate ventilation, exclusion of water from wood, or preservative treatment are absolutely essential in wood construction.

Thermal Properties/Temperature Effects:

Although wood is an excellent heat insulator, its strength and other properties are affected adversely by exposure for extended periods to temperatures above about 100°F. The combination of high relative humidity or MC and high temperatures, as in unventilated attic areas, can have serious effects on roof sheathing materials and structural elements over and above the potential for attack by decay organisms. Simple remedies and caution usually prevent any problems.

At temperatures above 220°F, wood takes on a thermoplastic behavior. This characteristic, which is rarely encountered in normal construction, is an advantage in the manufacture of some reconstituted board products, where high temperatures and pressures are utilized.

Environmentally friendly

Timber is the most environmentally responsible building material. Timber has low production energy requirements and is a net carbon absorber. Timber is a renewable resource. Well-managed forests produce timber on a sustained continuous basis, with minimal adverse effects on soil and water values.

In plentiful and growing supply

Timber is readily available. Australia has significant forest resources including a plantation estate covering more than 1.6 million hectares, and the area is growing rapidly.

Strong and lightweight

Timber is strong, light and reliable making timber construction simpler and safer than steel or concrete construction. A comparison with steel and concrete shows that radiata pine structural timber, for example, has a strength for weight ratio 20 percent higher than structural steel and four to five times better than unreinforced concrete in compression.

The lightweight structures possible in wood confer flow-on advantages in terms of reduced foundation costs, reduced earthquake loading and easier transport. Building components and complete constructions are simple and safe to erect, and cheaper to deconstruct or reuse at the end of a building's useful life.

Additionally, timber is:

Safe:

Timber has low toxicity and therefore requires no special safety precautions to work with it, other than normal protection from dusts and splinters. Timber frame construction requires little in the way of heavy lifting equipment making building sites safer work places. Timber being non-conductive has obvious benefits in terms of electrical safety. Modern timber construction has increased fire resistance due to incombustible linings protecting light frames.

Easy to install:

Increasingly specialist timber frame and truss manufacturers use high tech prefabrication enabling accurate and speedy installation. Recyclable -Timber is a forgiving material that can be easily disassembled and reworked. If demolition or deconstruction of a wooden building is necessary, many wood-based products can be recycled or reused. Timber trusses and frames, factory fabricated from sawn timber and toothed metal plate connectors, have come to dominate roof construction for small

buildings such as houses and large industrial buildings where clear spans up to 50 metres are required. Timber trusses compete with other roof structural systems on cost, high performance, versatility and ready availability, supported by design software packages supplied by the plate manufacturers to the fabricators.

Cost effective:

Comparative studies of the economics of different wall framing systems indicate that, in terms of direct building expenses, timber frames are consistently the most cost-effective solution. There are many factors to consider when comparing the economics of different construction systems including the complexity of the layout, site, builder experience, and relative material prices at the time of building. However, comparative studies of the economics of different wall framing systems indicate that, in terms of direct building expenses, timber frames are consistently the most cost-effective solution.

In the medium to long term, the forecasts for the Australian wood supply indicate a stable and growing supply. This means that prices for framing timber are likely to be more stable for builders in the long term. However, this price stability is questionable for materials such as steel, which consume considerable amounts of fossil fuels in their manufacture. The smelting of steel is heavily reliant on the continued availability of cheap sources of fossil fuels, a scenario which is becoming highly uncertain in an increasingly energy and security conscious world.

Durable:

Good detailing, coating and maintenance ensure that timber structures last for lifetimes. Although many buildings become obsolete and are demolished long before the end of their natural lives, timber buildings correctly designed and maintained can have an indefinite life. The key to long life is protection from weather, insect attack and decay, through well-established design detailing, surface coating systems, selection of durable species, and preservative treatment processes. In all countries of the world, and Australia is no exception, historic timber buildings testify to these principles.

In termite-prone areas, all buildings are vulnerable to termite attack of contents, so protection is needed regardless of construction materials. Protection systems rely on physical or chemical barriers, or both, and their effectiveness depends on the quality of the design, construction, inspection and maintenance. The risk of termite attack should be assessed after consulting with local building authorities and an appropriate termite management system should be implemented.

The system may include physical or chemical barriers or in higher risk areas, a termite resistant treated timber or naturally termite resistant frame may also be chosen. In any case any management system should include regular inspection to ensure that barriers have not been breached. It is therefore critical that the system type and inspection schedule are understood by all future householders. Importantly, termites are an integral part of the ecology of Australia, however, with awareness, planning and using cost effective systems, they can be effectively managed.

Comfortable:

Well-designed Timber structures are comfortable to live in all year round no matter where you are.

Flexible:

A particular feature of timber is the flexibility of design forms and finishes that can be used. This flexibility also extends to the ease with which existing buildings can be added to or modified to suit changing circumstances. User friendly versatile timber gives building designers creative freedom providing homeowners with flexible design choices. Timber is simply the best building material for builders, designers and homeowners and can be used to construct the homes we love, structures we admire and warehouses, commercial buildings and other structures. The timber frame method of building gives designers flexibility in both layout and external appearance. High levels of thermal insulation are incorporated within the construction, reducing heating costs and conserving energy.

Chemical Properties:

Chemical Effects:

Though, wood is chemically inert as compared to other materials but is affected by some acids and bases. Some species have proven very useful for food containers (berry boxes and crates) because they are nontoxic and impart no taste to the foods contained therein. Wood structures have also found widespread use as storage facilities for salt and fertilizer chemicals.

Lumber (American English; used only in North America) or **timber** (used in the rest of the English speaking world) is a type of wood that has been processed into beams and planks, a stage in the process of wood production.

Lumber may be supplied either rough-sawn, or surfaced on one or more of its faces. Besides pulpwood, *rough lumber* is the raw material for furniture-making and other items requiring additional cutting and shaping. It is available in many species, usually hardwoods; but it is also readily

available in softwoods, such as white pine and red pine, because of their low cost. *Finished lumber* is supplied in standard sizes, mostly for the construction industry – primarily softwood, from coniferous species, including pine, fir and spruce (collectively spruce-pine-fir), cedar, and hemlock, but also some hardwood, for high-grade flooring.

Lumber is mainly used for structural purposes but has many other uses as well. It is classified more commonly as a softwood than as a hardwood, because 80% of lumber comes from softwood.

TIMBER SEASONING:

Seasoning is the reduction of moisture content of timber to that of the surrounding air - Sydney area approx. 12.3%. Timber is seasoned to dry out the timber to bring it to a usable and workable condition. More than half the weight of freshly cut timber consists of moisture or sap. Before the timber can be used a large part of the moisture must be removed.

Methods of Seasoning:

Air Seasoning:

The timber is stacked on foundations to keep it off the ground. Strips of wood (about 38 x 19 mm) are placed between the layers of boards to allow air to circulate. Ends of boards may be painted to retard drying and prevent splitting. A waterproof covering is placed over the stack to protect the timber from the sun and the weather. Air seasoning is slow, taking up to a year for a piece 25 mm thick and considerably longer for thicker pieces. But the timber produced is well suited to outdoor work.

Kiln Seasoning:

Kiln seasoning is done in a large oven-like structure in which air circulation, humidity and temperatures are controlled. The timber is stacked on the trucks in the same way as for air drying. The trucks are on rails so that they can be moved into the kiln. Care must be taken to see that the drying process while removing the free water is not too rapid, as at this stage the timber is susceptible to degrade (damage) by checking and collapse. Many types of softwood, such as Radiata Pine, can be kiln dried easily and fairly cheaply from the green condition. But many of the Australian hardwoods are so slow in drying that their kiln drying is uneconomical. It is, however, satisfactory and economic to season them by the combined process of air and kiln drying mentioned below. Kiln Seasoning

- Kiln seasoning is done in a large oven-like structure in which air circulation, humidity and temperatures are controlled. The timber is stacked on the trucks in the same way as for air drying. The

trucks are on rails so that they can be moved into the kiln. Care must be taken to see that the drying process while removing the free water is not too rapid, as at this stage the timber is susceptible to degrade (damage) by checking and collapse. Many types of softwood, such as Radiata Pine, can be kiln dried easily and fairly cheaply from the green condition. But many of the Australian hardwoods are so slow in drying that their kiln drying is uneconomical. It is, however, satisfactory and economic to season them by the combined process of air and kiln drying mentioned below.

Reasons for Seasoning:

Air - natural circulation of air around & through timber stacks. --- Time - 3-9 months, sometimes years. - Kiln - forced drying of timber stacks in large containers called kilns - Time 1-3 weeks. - Combination of Air & Kiln - combines advantages of both air and kiln. - Solar kilns – rely on solar energy to aid the drying process - Time 1-3 weeks for more information on seasoning of timber go to Drying timber in Australia. Seasoned timber has many advantages over unseasoned timber, such as: improved strength and hardness

- To prevent shrinkage, splitting, checking and warping.
- To achieve greater stiffness and strength.
- To allow penetration of preservatives
- To obtain a surface that will accept paint, polish or glue.
- To protect against decay.

FORM WORK (SHUTTERING):

Formwork is the term given to either temporary or permanent moulds into which concrete is poured till it get sufficient strength for self-supporting.

The form work involves various materials such as timber (wood), plywood, steel, aluminium, combined wood–steel etc... used as moulds in civil structures, in which concrete is poured. The construction of form work involves considerable materials. The cost of form work may be upto 20 – 25 % of the cost of the structure in building works and even higher in bridges. In order to reduce this expenditure, it is necessary to design economical types of form work.

When the concrete reach a certain required strength, the form work is no longer needed and is removed. The operation of removing the form work is commonly known as Stripping. Similarly, when the

components of form work are removed and then reused for other parts of the civil structure for several times are known as Panel forms.

FORMWORK MATERIALS:

Timber is the most common material used for form work. When the form work is to be used for small works only a few times, then timber proves to be more economical than steel or aluminum.

Advantages: Formwork material of timber is

- Easily available
- Formwork material can be made to desired shape
- Can be made to required size
- Easy to carry
- Economically viable and cheap
- Convenient for small works

Disadvantages:

- Possibility of warping, swelling and shrinkage of timber. However, those effects can be overcome by applying shuttering oil as coating. This coating prevents the material from adhering to concrete and hence the stripping (removing of formwork material) makes easier.

Steel/ Aluminum formwork: If the formwork is desired to be re-used several times, then the use of steel or aluminum is preferred. Though the initial cost of steel is very high but for large works with many repetitions, the steel form work proves to be economical. In case of specific structures, such as round columns, curved surfaces, tunnels etc the use of steel form work should be made.

Steel form work has many advantages such as:

- Can be used a number of times
- It provides ease stripping
- It ensures an even and smooth concrete surface.
- It is not liable to shrinkage/ swelling.

Requirements for a Form work: A good form work should satisfy the following requirements:

- The material of the formwork should be cheap and it should be suitable for re-use several times.
- It should be water proof so that it doesn't absorb water from concrete.
- Shrinkage and swelling of material should be minimum.

- It should be strong enough to withstand all loads coming on it such as dead load of concrete, live load of concrete during its pouring, compaction and curing of concrete.
- The surface of the form work material should be smooth and should afford easy stripping.
- All joints of the form work should be stiff so that lateral deformation under loads is minimized.

Indian Standards on form work (IS 456 – 2000)

General: The formwork shall conform to the shape, dimensions etc as shown on the plans and soconstructed as to remain the rigidity during the placing of the concrete and the form work shall be sufficiently tight to prevent loss of liquid from the concrete.

Cleaning and treatment of forms: All rubbish particularly chippings, saw dust shall be removed fromthe interior of the form work material before the concrete is placed.

Procedure to be adopted for removing the form work: All form work materials are to be removedwithout creating vibrations as would damage the reinforced concrete. Before the form work materials are removed, the concrete surface should be checked thoroughly.

Tolerances: Form work shall be so constructed that the internal dimensions are within the permissibletolerance specified by the designer.



Formwork material (PLYWOOD) and Modular steel frame work

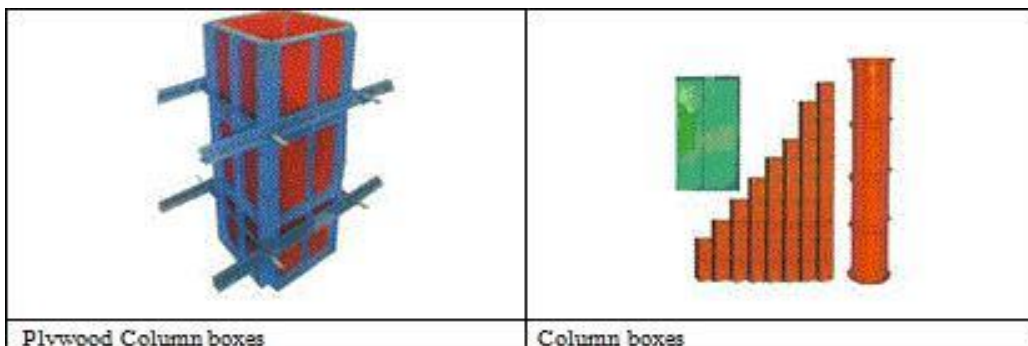

SCAFFOLDING:

The Scaffolding is a temporary frame work of timber or steel components having platforms at different levels, to enable the masons to work at different heights of a buildings. When the height of wall or column or other structure of a building exceeds about 1.5 mts (4'), temporary structures are used to support the platform over which the work men can sit and carry the activities.

These temporary structures constructed are very close to the wall, is in the form of timber or steel frame work, commonly called scaffolding. Scaffolding materials is needed for the repairs or even demolition of a building. In addition, surface finishing such as plastering, pointing, white washing or distempering of walls, columns etc at higher levels can also be carried out. The scaffolding should be stable and be strong enough to support work men and other construction material placed on the platform. The height of the scaffolding goes on increasing as the height of construction increases.

Components of Scaffolding:

Standards: These are the vertical members of the frame work supported on the ground or embedded into the ground.

Ledgers: These are horizontal members, running parallel to the wall,

Braces: These are diagonal members fixed on standards.

Putlogs: These are transverse members, placed at right angles to the wall with one end supported on ledgers and other end on the wall.

Transoms: These are those putlogs whose both ends are supported on ledgers.

Boardings: These are horizontal platform to support workmen and material and are supported on the putlogs. Various components or members of the scaffolding are secured by means of rope lashings, nails, bolts etc.....

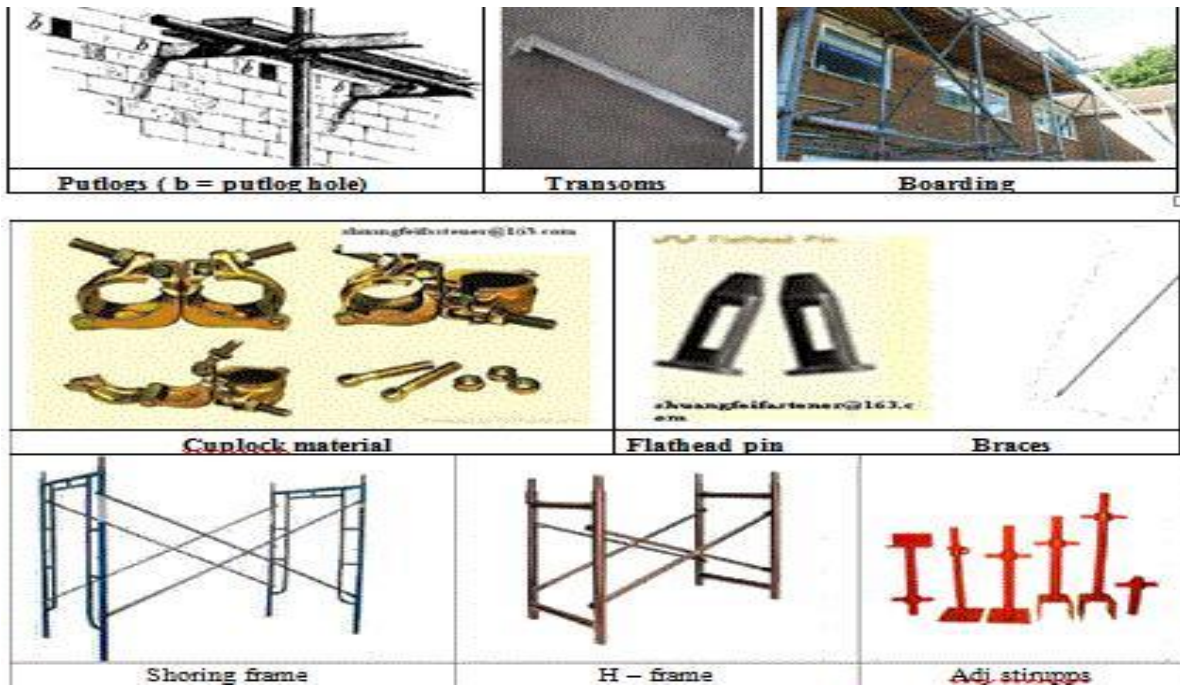

TYPES OF SCAFFODING:

Single / Bricklayer's / Putlog scaffolding: It consists of a single row of standards (vertical members) which are driven into the ground. Standards are to be arranged parallel to the wall at distance of 1.20 mts. The standards are then connected to each other by ledgers (horizontal members) placed at right angles. They are secured in position by rope lashings or cuplock materials. The put logs are fastened to ledgers by rope lashings. The cross braces are used for strengthening of the structure.

Double scaffolding/ Mason's Scaffolding: This type of scaffolding is stronger than the single scaffolding and is used in the constructions of stone work. The form work is similar to the single scaffolding except two rows of standards are used, one row close to the wall within 15 cm and the other at 1.2 to 1.5 m away from the face of the wall. The put logs are supported at both ends on ledgers. Sometimes, in addition to the diagonal braces, inclined supports called Racking shores are provided to prevent the slipping of scaffold away from the wall.

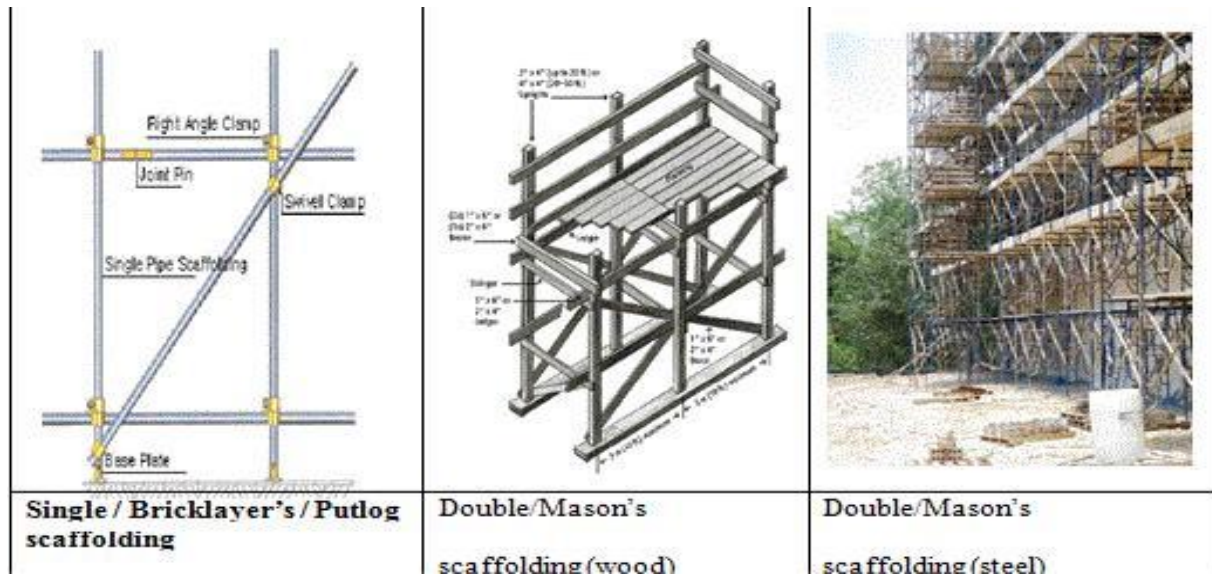

Cantilever Scaffolding / Needle Scaffolding: This type of scaffolding is needed under the following circumstances:

- Where it is not possible to fix the standards in to the ground
- Where the scaffolding is to be provided on the side of a busy street without obstructing the traffic on road.
- Where the scaffolding is required in case of tall buildings.

In this work, single scaffolding or double scaffolding components are supported by a series of cantilevers or needle beams (timber beams projecting from wall) passing through window openings or through holes in the wall.

Suspended scaffolding: This type of scaffolding is suitable for maintenance works such as painting, pointing, distempering etc. The working platform is suspended from the roofs by means of wire ropes or chains.. The mechanical arrangements are provided to raise or lower the platform to attain the optimum level for working.

Trestle scaffolding: The working platform is supported on the top of mobile devices such as tripods, ladders etc mounted on wheels. Trestle scaffolding is suitable for minor repairs or painting work upto a maximum height of 5 mts from the supporting level.

Steel scaffolding/Centering: It is practically similar to timber scaffolding except that wooden members are replaced by steel tubes and rope lashings are substituted by special couplings and set-screws at junctions. Though its initial cost is more but its salvage (The property so saved) value is higher.

Ladder Scaffolding / Patented scaffolding: The working platforms are supported on brackets (with inner row of standards) which can be adjusted at any suitable height. The various components of the scaffold are fastened to each other by means of bolts and screws.

Stone Masonry and brick stone masonry:

Definition:

The art of building a structure in stone with any suitable masonry is called stone masonry.

Types of Stone Masonry:

Stone masonry may be broadly classified into the following two types:

- 1) Rubble Masonry
- 2) Ashlars Masonry

Rubble Masonry:

The stone masonry in which either undressed or roughly dressed stone are laid in a suitable mortar is called rubble masonry. In this masonry the joints are not of uniform thickness. Rubble masonry is further sub-divided into the following three types:

- Random rubble masonry
- Squared rubble masonry
- Dry rubble masonry

Random rubble masonry: The rubble masonry in which either undressed or hammer dressed stones are used is called random rubble masonry. Further random rubble masonry is also divided into the following three types:

Uncoursed random rubble masonry: The random rubble masonry in which stones are laid without forming courses is known as un coursed random rubble masonry. This is the roughest and cheapest type of masonry and is of varying appearance. The stones used in this masonry are of different sizes and shapes. before lying, all projecting corners of stones are slightly knocked off. Vertical joints are not plumbed, joints are filled and flushed. Large stones are used at corners and at jambs to increase their strength. Once "through stone" is used for every square meter of the face area for joining faces and backing.

Suitability: Used for construction of walls of low height in case of ordinary buildings.

Coursed random rubble masonry: The random rubble masonry in which stones are laid in layers of equal height is called random rubble masonry. In this masonry, the stones are laid in somewhat level courses. Headers of one coursed height are placed at certain intervals. The stones are hammer dressed.

Suitability: Used for construction of residential buildings, go downs, boundary walls etc.

Squared rubble masonry: The rubble masonry in which the face stones are squared on all joints and beds by hammer dressing or chisel dressing before their actual laying, is called squared rubble masonry.

There are two types of squared rubble masonry.

Coursed Square rubble masonry: The square rubble masonry in which chisel dressed stones laid in courses is called coarse square rubble masonry. This is a superior variety of rubble masonry. It consists of stones, which are squared on all joints and laid in courses. The stones are to be laid in courses of equal layers. and the joints should also be uniform.

Suitability: Used for construction of public buildings, hospitals, schools, markets, modern residential buildings etc and in hilly areas where good quality of stone is easily available.

Uncoursed square rubble masonry: The squared rubble in masonry which hammer dressed stones are laid without making courses is called un coursed square rubble masonry. It consists of stones which are squared on all joints and beds by hammer dressing. All the stones to be laid are of different sizes.

Suitability: Used for construction of ordinary buildings in hilly areas where a good variety of stones are cheaply available.

Dry rubble masonry: The rubble masonry in which stones are laid without using any mortar is called dry rubble masonry or sometimes shortly as "dry stones". It is an ordinary masonry and is recommended for constructing walls of height not more than 6m. In case the height is more, three adjacent courses are laid in squared rubble masonry mortar at 3m intervals.

Ashlar masonry:

The stone masonry in which finely dressed stones are laid in cement or lime mortar is known as ashlar masonry. In this masonry are the courses are of uniform height, all the joints are regular, thin and have uniform thickness. This type of masonry is much costly as it requires dressing of stones.

Suitability: This masonry is used for heavy structures, architectural buildings, high piers and abutments of bridges.

Ashlars masonry is further sub divided into the following types:

- Ashlars fine or coarse ashlar masonry
- Random coarse ashlars masonry
- Rough tooled ashlar masonry
- Rock or quarry faced ashlars masonry
- Chamfered ashlars masonry

- Block in coarse masonry
- Ashlar facing

Ashlar fine or coarse ashlar masonry: In this type of stone masonry stone blocks of same height in each course are used. Every stone is fine tooled on all sides. Thickness of mortar is uniform throughout. It is an expensive type of stone masonry as it requires heavy labor and wastage of material while dressing. Satisfactory bond can be obtained in this type of stone masonry.

Random coursed ashlar masonry: This type of ashlar masonry consists of fine or coursed ashlar but the courses are of varying thicknesses, depending upon the character of the building.

Rough tooled ashlar masonry: This type of ashlar masonry the sides of the stones are rough tooled and dressed with chisels. Thickness of joints is uniform, which does not exceed 6mm.

Rock or quarry faced ashlar masonry: This type of ashlar masonry is similar to rough tooled type except that there is chisel-drafted margin left rough on the face which is known as quarry faced.

Chamfered ashlar masonry: It is similar to quarry faced except that the edges are beveled or chamfered to 45° for depth of 2.5 cm or more.

Block-in course masonry: It is the name given to a class of ashlar masonry which occupies an intermediate place between rubble and ashlar. The stones are all squared and properly dressed. It resembles to coursed rubble masonry or rough tooled ashlar masonry.

Ashlar facing: Ashlar facing is the best type of ashlar masonry. Since this type of masonry is very expensive, it is not commonly used throughout the whole thickness of the wall, except in works of great importance and strength. For economy, the facing is built in ashlar and the rest in rubble.

UNIT -V

STAIRS AND BUILDING PLANNING

A stairway, staircase, stairwell, flight of stairs, or simply stairs is a construction designed to bridge a large vertical distance by dividing it into smaller vertical distances, called steps. Stairs may be straight, round, or may consist of two or more straight pieces connected at angles.

Special types of stairs include escalators and ladders. Some alternatives to stairs are elevators, stairlifts and inclined moving walkways as well as stationary inclined sidewalk.

A stair, or a stairstep is one step in a flight of stairs. In buildings, stairs is a term applied to a complete flight of steps between two floors. A stair flight is a run of stairs or steps between landings. A staircase or stairway is one or more flights of stairs leading from one floor to another, and includes landings, newel posts, handrails, balustrades and additional parts. A stairwell is a compartment extending vertically through a building in which stairs are placed. A stair hall is the stairs, landings, hallways, or other portions of the public hall through which it is necessary to pass when going from the entrance floor to the other floors of a building. Box stairs are stairs built between walls, usually with no support except the wall strings.

Step:

Each step is composed of tread and riser.

Tread:

The part of the stairway that is stepped on. It is constructed to the same specifications (thickness) as any other flooring. The tread "depth" is measured from the outer edge of the step to the vertical "riser" between steps. The "width" is measured from one side to the other.

Riser:

The vertical portion between each tread on the stair. This may be missing for an "open" stair effect.

Nosing:

An edge part of the tread that protrudes over the riser beneath. If it is present, this means that, measured horizontally, the total "run" length of the stairs is not simply the sum of the tread lengths, as the treads overlap each other.

Starting step or Bull nose:

Where stairs are open on one or both sides, the first step above the lower floor or landing may be wider than the other steps and rounded. The balusters typically form a semicircle around the circumference of the rounded portion and the handrail has a horizontal spiral called a "volute" that supports the top of the balusters. Besides the cosmetic appeal, starting steps allow the balusters to form a wider, more stable base for the end of the handrail. Handrails that simply end at a post at the foot of the stairs can be less sturdy, even with a thick post. A double bull nose can be used when both sides of the stairs are open.

Stringer, Stringer board or sometimes just String.

The structural member that supports the treads and risers in standard staircases. There are typically three stringers, one on either side and one in the center, with more added as necessary for wider spans. Side stringers are sometimes dadoed to receive risers and treads for increased support. Stringers on open-sided stairs are called "cut stringers".

Winders

Winders are steps that are narrower on one side than the other. They are used to change the direction of the stairs without landings. A series of winders form a circular or spiral stairway. When three steps are used to turn a 90° corner, the middle step is called a kite winder as a kite-shaped quadrilateral.

Trim

Various moldings are used to decorate and in some instances support stairway elements. Scotia or quarter-round are typically placed beneath the nosing to support its overhang.

The railing system[edit]

- A multi-flight stairway with handrails
- Stone stairs and wooden balustrade
- Two flights of stairs joined by a landing

Example of winder stairs with a simple handrail supported by three newel posts

The balustrade is the system of railings and balusters that prevents people from falling over the edge.

Banister, Railing or Handrail

The angled member for handholding, as distinguished from the vertical balusters which hold it up for stairs that are open on one side; there is often a railing on both sides, sometimes only on one side or not at all, on wide staircases there is sometimes also one in the middle, or even more. The term "banister" is

sometimes used to mean just the handrail, or sometimes the handrail and the balusters or sometimes just the balusters.

Volute :

A handrail end element for the bullnose step that curves inward like a spiral. A volute is said to be right or left-handed depending on which side of the stairs the handrail is as one faces up the stairs.

Turnout:

Instead of a complete spiral volute, a turnout is a quarter-turn rounded end to the handrail.

Gooseneck :

The vertical handrail that joins a sloped handrail to a higher handrail on the balcony or landing is a gooseneck.

Rosette :

Where the handrail ends in the wall and a half-newel is not used, it may be trimmed by a rosette.

Easings Wall handrails are mounted directly onto the wall with wall brackets. At the bottom of the stairs such railings flare to a horizontal railing and this horizontal portion is called a "starting easing".

At the top of the stairs, the horizontal portion of the railing is called a "over easing".

Core rail Wood handrails often have a metal core to provide extra strength and stiffness, especially when the rail has to curve against the grain of the wood. The archaic term for the metal core is "core rail".

Baluster.

A term for the vertical posts that hold up the handrail. Sometimes simply called guards or spindles.

Treads often require two balusters. The second baluster is closer to the riser and is taller than the first.

The extra height in the second baluster is typically in the middle between decorative elements on the baluster. That way the bottom decorative elements are aligned with the tread and the top elements are aligned with the railing angle.

Newel

A large baluster or post used to anchor the handrail. Since it is a structural element, it extends below the floor and subfloor to the bottom of the floor joists and is bolted right to the floor joist. A half-newel may be used where a railing ends in the wall. Visually, it looks like half the newel is embedded in the wall. For open landings, a newel may extend below the landing for a decorative newel drop.

Finial

A decorative cap to the top of a newel post, particularly at the end of the balustrade.

Base rail or Shoe rail

For systems where the baluster does not start at the treads, they go to a base rail. This allows for identical balusters, avoiding the second baluster problem.

Fillet

A decorative filler piece on the floor between balusters on a balcony railing.

Handrails may be continuous (sometimes called over-the-post) or post-to-post (or more accurately "newel-to-newel"). For continuous handrails on long balconies, there may be multiple newels and tandem caps to cover the newels. At corners, there are quarter-turn caps. For post-to-post systems, the newels project above the handrails.

BUILDING PLANNING:

Plan of a typical floor: The plan of a typical floor (ground floor plan at ground floor level , first floor plan at first floor level) is represented by a Plan cut at the window sill level so that all the windows, cup boards, almirahs etc are also represented on the plan.

Foundation plan: Foundation is immediate beneath the lowest part of the structure, near to the ground level is known as shallow foundations. Such foundations are mostly placed on the hard strata available below the ground level.

Shallow foundations are further classified into the following types:

1. Open trench foundations:

The open-trench foundations were common whenever the terrain was sufficiently compact and the trench did not require much depth. In other situations, it was necessary to reinforce the walls of the trench to prevent them from collapsing during digging

2. Grillage foundations: Grillage foundation is used when heavy structural loads from columns, piers or stanchions are required to be transferred to a soil of low bearing capacity. Grillage foundation is often found to be lighter and more economical. This avoids deep excavation. Depending upon the material used in construction of grillage foundation can be broadly divided in the following two categories.

- Steel grillage foundation
- Timber grillage foundation
- Raft foundations:

A foundation (usually on soft ground) consisting of an extended layer of reinforced concrete.

Stepped foundations:

A foundation constructed in a series of steps that approximate the slope of the bearing stratum. The purpose is to avoid horizontal force vectors that might cause sliding.

Inverted arch foundations/ Footing:

It is used to be provided for multi-storied buildings in olden times. However, with the advent of reinforced cement concrete construction practice, inverted arch footing is rarely done these days. One of the drawbacks in this type of construction is that the end piles have to be specially strengthened by buttresses to avoid the arch thrust tending to rupture the pier junction. However, the advantage of inverted arch construction is that in soft soils the depth of foundation is greatly reduced

Structural plan of a typical floor: A structural plan of a typical floor contains location, nomenclature and details of various structural elements at that floor level.

Terrace plan. The terrace plan is the plan at the roof level showing the stair cabin, lift cabin, overhead water tanks along with roof drainage pattern, parapet walls etc.

Classification of buildings: According to National Building code of India 1970, different classification of buildings on the basis of occupancy are:

Group A – Residential Buildings: All those buildings in which sleeping accommodation is provided for residing permanently or temporarily with or without cooking or dining or both facilities are termed as residential buildings, for example Apartments, Flats, Bungalows, Dormitories, Private Houses, Hotels, Hostels, Cottages, Holiday Campus, Clubs, outhouses, Inns, etc., These buildings are further sub-divided in to 5 groups, namely; A- 1 Lodging Houses; A- 2 Family Private Dwellings; A- 3 Dormitories; A- 4 Flats; and A- 5 Hot

Group B – Educational Buildings: All those buildings which are meant for education from a nursery to the university, are included in this group, for example, schools, colleges, Universities, Training Institutes, etc. These buildings provide facilities like class – rooms, staff cabins, drawing rooms, laboratories, admin blocks, seminar halls; recreation halls, library, playfields, gymnasium etc.

Group C – Institutional Buildings: This group includes any building which is used for the purposes such as medical, health, physical or mental disease, care of infants or aged persons, etc. These buildings normally meant for healthcare for the occupants.

These buildings are further sub-divided into three groups viz, C-1 Hospitals; C-2 Custodian Institutions (a financial institution that has the legal responsibility for a customer's securities) and C-3 panel Institutions (a group of persons selected for some services).

Group D – Assembly Buildings: This group includes any building where groups of people assemble or gather for amusement / entertainment. For eg: theatres, cinema halls, assembly halls, auditoriums, exhibition halls, museums, restaurants, places of worship (temple, mosque, church, etc.), club rooms, passenger stations, public transportation services; open air theatres, sports pavilions(i.e., stadium), swimming pools, etc.

Group E – Business Buildings : A commercial building is a building that is used for commercial use. Types can include office buildings, warehouses, shopping malls, etc

Group F – Mercantile Buildings: This group includes any building or part of a building which is used as shops, stores, market for sale and display of products or wares either wholesale or retail.

Group G – Industrial Buildings: This group includes any building in which products of different kinds and properties, are fabricated, assembled or processed. For example, laboratories, assembling plants, laundries, gas plants, power plants, refineries, dairies...

Group H – Storage Buildings: This group includes to store materials such as cement, iron/steel; home appliances etc. eg: godowns

Group I – Hazardous Buildings: This group includes those building structures which are used for the storage, handling, manufacture/ processing of materials which are liable to burn and prove hazardous to building contents. Hazards may be due to fire, poisonous fumes or gases , explosions, ignition, etc., from materials subjected to various operations. Buildings used for storage of explosive materials, manufacture of synthetic leather, explosives, fire works

BASIC PRINCIPLES OF BUILDING PLANNING: The basic principles of building planning in respect of residential buildings are:

(1) **FLOOR AREA RATIO (FAR)** is the ratio of the total covered area of all floors in a building on a certain plot and to the area of the plot.

The Floor Area Ratio, describes the relationship between the size of a plot and the amount of floor space it contains. For example, a 50' x 100' lot (5,000 sft) with a single-story 50' x 50' building (2,500sft) has a floor area ration of 0.5. If a building with the same size footprint had 4 stories, the FAR would increase to 2. Higher FARs tend to indicate more urban (dense) construction and is used by local governments in zoning codes

(2) **FLOOR SPACE INDEX (FSI):** It is the ratio of built up area inclusive of walls of all the floors and to the area of the land on which the building stands.

Total floor area including walls of all floors Floor Space Index = Plot Area / Building Unit

(4) **THE AREA OF ROOMS:**

Bed rooms, living rooms, drawing room, dining room (min) ...9.4 sqmts

Kitchen and store rooms (min)

5.45 sq mts

Bathrooms and dressing rooms ...

1.85 – 4.5 sqmts

Water Closet (WC); Urinal rooms .0.89 – 1.1 sqmts

(5) **HEIGHT OF ROOF:** Roof height on each floor is 2.7 mts (min) and for bath room and WC is 2.1 mts (min)

(6) **AREA OF DOORS, WINDOWS & VENTILATORS:** This shall be 1/6th to 1/10th of the floor area of the room. In addition, every room should have ventilator.

(7) STAIR CASE: The stair case shall have area not more than 12 sq mts. The pitch shall be in the range of 30° to 45° and flight shall have steps neither < 3 nor > 12. Minimum width of stair shall be 900 mm.

(8) LIFT: This shall be provided for buildings having more than 3 floors excluding the ground floor.

(9) SEPTIC TANK: shall be provided as per number of floors / rooms

(10) HEIGHT OF COMPOUND WALL: The maximum height of compound

PARKING SPACE: Parking spaces for cars required for cinemas, shopping areas and offices located in central areas are to be allocated as per National Building Code.

BUILDING BYE-LAWS: Every locality has its own peculiarities in respect of weather conditions, availability of material and labor and thus adopts its own method of construction. In addition, every locality has certain rules and regulations which help in controlling the development of locality. The rules and regulations covering the requirements and ensure the safety of the public, minimum use of rooms, area limitations are known as “Building bye-laws”.

Building bye-laws are necessary to achieve the following objects:

- Gives guidelines to the architects / engineer and thus help in pre-planning the building activities.
- Allow to prevent haphazard development
- Afford safety against fire, noise pollution, structural failures etc.

While framing building bye-laws assistance of experts on various subjects such as town planning, law, health, civil engineering, traffic, general administrations etc should be sought due its weightage.

Indian Standard Institution, an organization of Govt of India has published IS 1256 “code of building laws” covering all the salient aspect of building activities. National Building Code (NBC) was published by the Govt of India for smooth running of building activities by realizing the importance of building bye-laws.

From Newton's first law of motion even though the base of the building moves with the ground, the roof has a tendency to stay in its original position. But since the walls and columns are connected to it, they drag the roof along with them. This gives rise to inertia forces on the roof element. Structural elements such as floor slabs, walls, columns and foundations and the connections between them must be designed to safely transfer these inertia forces through them. Walls or columns are the critical elements in transferring the inertia forces. But in traditional construction, slabs and beams receive more care and attention during design and construction than walls and columns. Failure of masonry walls have been observed because of their thin and materials used for it, in the past due to some Basic Principles of Building Planning.

Why to do Building Planning?

Planning in construction is the first thing to do. Proper orientation, healthy, beautiful, economical etc are our targets to achieve by planning building construction or any other construction work.

Principles of Building Planning

When we first start to plan a new building construction work to begin we definitely need to remember some basic principles of building planning. Some of the basic principles of planning of a building construction are given below.

1. An engineer or architect should prepare the building plan according to the demand, economic status & taste of the owner and also the purpose of the building is to be built whether residential, commercial etc.
2. The design of the building should be compatible with the surrounding structures & the weather.
3. Sufficient air and sunlight should be allowed to the building for healthy building **environment**.
4. Privacy must be **maintained** especially in residential building planning.
5. Proper security system should be introduced for safety and reliability.
6. Fire safety alarm and firefighting materials should be provided within the range of the inhabitants of the proposed building **structure**.
7. The value of the structure should be maintained in building plans.
8. Follow the associated building **codes** closely for **proper building construction**.

Example:

Some important factors to consider for building planning are as follows.

- Aspect
- prospect
- Furniture requirements
- Roominess
- Grouping
- Circulation
- Privacy
- Sanitation
- Elegance
- Economy
- Flexibility
- Practical considerations.
- “Lower storey of a building having minimum half the clear floor area height of the basement of cellar below average ground floor.”
 - Basement is not permitted in margins
 - Area of basement $< 2 \times$ Area of plinth or plot whichever is less
 - Use of wood as structural member is not permitted.
 - Proper ventilation should be provided in the basement.
 - It should not be connected with water or drainage lines.
 - Depth of basement should not exceed 1.5m below ground level.
 - permission can be granted for other basement below for parking purpose but total depth should not exceed 6m.

Types of Building

1. Apartments: Building with more than one storey and combined construction
2. Assembly building: Buildings where group of people gather for amusement, social, religions, recreation, patriotic, civil, travel or similar purposes
3. Business building: Building used for transaction of record, offices, banks etc.
4. Chawl : Building prepared for rental purpose, each tenant will have two rooms & bathrooms and toilets are combined

Types of Building

5. Educational Building: Exclusively used for schools and collages
6. Mercantile Building: Building used as shops, stores market for display
7. Row houses: Building having residential units provided in row with same plans

8. Storage building: Building used for storage or shelter of goods, ware house, cold storage

Types of Building

9. High rise building: Building having height more than 15m but less than 30m

10. Low rise building: Building having height less than 15m

11. Industrial building: Building in which products or materials are fabricated, assembled or processed

12. Institutional Building: Building constructed for public activities like medical, education, etc.

Building Unit

“it is one or more than one plots approved by the competent authority for width of plot less than 10.5m”

Plot width less than 3m and area less than 18m² is not considered as building unit

“Line up to which the plinth of a building adjoining a street may be law-fully extended is called **building line.**”

Common plot for residential and commercial buildings

Open space or the purpose of entertainment shall have to be kept when the area of layout exceeds 0.3 hectars Common plot should be located at one place only however pockets may be permitted.

Minimum area should not be less than

- (i) 15% of the area of layout
- (ii) 0.3 to 0.4 hector/1000 persons
- (iii) 0.3/1000 persons for low income group housing

Common plot for industrial zone

For industrial unit having area more than 0.8 hectars, & 5% area shall be reserved for amenities, such area can be used for general parking.

If this area is more than 1500 m² buildings for bank, canteen, welfare centers can be made in this additional area

For industries having area > 1000 m² then 10% space reserved for amenities

This amenities area should be maximum 2500 m².

Margins for special buildings

Margins on sides other than road side

Margins for industrial use

Maximum permissible built up area on any floor including ground floor shall be 50% of plot area.

Maximum side margins along perimeters of plot

- (i) plot with area more than 1000m² should be 6m
- (ii) plot with area up to 1000m² should be 4.5m

Minimum clear distance between two detached structures should be 6m and 4.5m as suggested above.

Margins high rise building

High rise buildings shall be permitted on roads more than 12m wide.

Side margins should be 6m or $0.2 \times \text{Height}$ whichever is more.

Road side margins for roads

Up to 30m = $0.3 \times \text{Height}$ or 9m whichever is more

More than 30m = $0.3 \times \text{Height}$ or 9m whichever is more

Mezzanine floor

“It is an additional floor provided between two consecutive floors.”

Its area < 1/3 of plinth area

Height < 2.2m

It should not be used as kitchen and it should not be divided.

It should be properly ventilated and its area should not be less than 9.5m^2 if it is proposed to be used as a habitable room.

Compound wall

“This is the wall made around the building which cover up the whole building”

Height of compound wall abutting road should not be more than 1.5m.

Height of compound walls on other sides should be less than 1.8m.

If opening in the portion above 0.9m are provided the height can be 2.4m.

Compound wall

Gate is not permitted on the curvature at the junction of roads.

Gate should be 15m away from junction.

Shutter of compound wall gate should not open outside on road side.

Height of compound wall should not be more than 0.75m above crown of road.

Local authority permits 2.4m height of compound wall for public buildings like industries, hospitals, etc.

“A room occupied or designed for occupancy by one or more persons for study, living, sleeping, eating, kitchen if it is used as living room.”

Rooms like water closets, bathroom, store, pantries, laundries, cellars, etc. are not generally considered into habitable rooms.

Habitable Room

Height of habitable room > 2.75m for regular

> 2.4m for air conditioned

> 2.6m for row houses

Every side must be greater than 2.4m in length

minimum area for first room > 9.5m²

Other rooms > 7.5m²

Head Room

“Clear height from top of floor to the bottom of ceiling.”

Minimum head rooms for different types of building

- 1) Residential & commercial – 2.75m
- 2) Educational – 3.6m & 3m(for cold area)
- 3) Industrial – 3.6m & 3m (for A/C)

Height of Building

“Maximum Height of building will depend upon the width of street on which the building is abutting”

Lift

Lift shall be provided when the height of the building exceeds 15m.

Two lift is required when height of building exceeds 21m.

For residential apartments there should be one lift for 20 flats

For non-residential buildings lifts should be at the rate of one lift on one lift per 1000 m².

Generator is advisable with the lift for the safety purpose where electricity cuts more often.

Lift capacity

For high rise,

residential building – 8 persons

other building – 12 persons

For low rise,

residential building – 4 persons

other building – 8 persons

Lift dimensions of lift should be as per NBC.

Loft

Head room below loft should not be less than 2.2m

Height of loft should not be more than 1.5m

Area of loft should not exceed ¼ area of room

Bath and Water closet can be fully covered by loft.

Minimum Stair width

Parking

Separate provisions for cars, scooters, visitors should be made

Common plot must not be used for parking

Head room for the road leading to parking should not be less than 2.1m

For a car – 14m² area required

For a motor cycle – 1.25 m² area required

For a cycle – 0.8 to 1 m² area required

Parking area for different buildings

Set back

“Some distance kept between road line and a plinth of building parallel to road line.”

This land though remains in possession of the owner of the plot.

Can be utilized for widening of road in future

1.5m set back for roads up to 12m.

2m set back for the road wider than 12m.

Advantages of Set back

- Availability of sufficient light & ventilation.
- Availability of land for widening of roads in future.
- Availability of sufficient sight distance at road crossings.
- Availability of space for parking.
- Availability of necessary privacy.
- Reduction of unwanted noise.
- Road width for residential building
- Road width for other buildings

Unsafe Building :

It is considered as dangerous from public safety point and must be repaired properly or demolished

Authority will arrange to examine such building and keep record.

Owner or occupier shall be given written legal notice stating defects of the building.

Owner or occupier shall arrange for the stated repairs or demolition to the satisfaction of the authority within the period stated in the notice.

Unsafe Building

In case any person is not vacating the building the authority may take police action against him.

If a person fails to comply with the requirements of the notice, authority will repair or demolish the structure.

The cost incurred for the repairs or removal of structure shall be charged to the owner of the premises.

Ventilation

For habitable room, the area of clear total opening excluding frames should not be less than $\frac{1}{10}$ the floor area of room.

Windows or ventilators provided for ventilation should abut exterior open space, or open verandah or gallery.

For factory or go-downs clear area of windows and ventilators should not be less than $\frac{1}{7}$ floor area.

Ventilation

The width of the open space on which the ventilators should not be less than $\frac{1}{3}$ height of building.