

CELLULAR MOBILE COMMUNICATION

LECTURE NOTES

B.TECH (IV-I SEM)

(2018-19)

PREPARED BY

MRS.S.RAJANI, ASSISTANT PROFESSOR

MRS.K.BHAVANA, ASSISTANT PROFESSOR

MRS.B. SRUJANA, ASSISTANT PROFESSOR

MS.M.NAGMA, ASSISTANT PROFESSOR

DEPARTMENT OF ELECTRONICS AND COMMUNICATION
ENGINEERING



**MALLREDDY COLLEGE OF ENGINEERING AND
TECHNOLOGY**

(Autonomous Institution – UGC, Govt. of India)

Recognized under 2(f) and 12 (B) of UGC ACT 1956

(Affiliated to JNTUH, Hyderabad, Approved by AICTE - Accredited by NBA & NAAC – 'A' Grade - ISO 9001:2015 Certified)

Maisammaguda, Dhulapally (Post Via. Kompally), Secunderabad – 500100, Telangana State, India

MALLA REDDY COLLEGE OF ENGINEERING AND TECHNOLOGY

IV Year B.Tech. ECE-I Sem

L	T/P/D	C
4	1/ - /-	3

(R15A0422) CELLULAR AND MOBILE COMMUNICATIONS**OBJECTIVES:**

The course Objectives are

- To provide the students with an understanding of the cellular concept frequency reuse, handoff strategies.
- To enable the students to analyze and understand wireless and mobile cellular communication systems over stochastic fading channels .
- To provide the students with an understanding of Co-channel and Non-Co channel Interference.
- To give students an understanding of cell coverage for signal and traffic diversity techniques and mobile antennas.
- To give the students an understanding of frequency management channel assignment and types of handoff.

UNIT I**CELLULAR SYSTEMS:**

Limitations of Conventional System , Basic Cellular Mobile System ,First, second ,third and fourth Generation cellular wireless systems .Operation of Cellular System .Uniqueness of Mobile Radio Environment –Fading ,coherence bandwidth,Doppler Spread.

Fundamentals of cellular Radio System Design: concept of frequency reuse channels, Co-channel Interference, Co-channel Interference Reduction Factor, desired C/I from a normal case in a Omni directional Antenna system .Trunking and grade of service

UNIT II**CO-CHANNEL & NON CO-CHANNEL INTERFERENCE:**

Measurment of Real Time Co-Channel Interference, design of Antenna system, Antenna parameters and their effects, diversity techniques: Space Diversity ,Polarization diversity, frequency diversityand time diversity.

Non-co channel interference-adjacent channel interference, Near End far end interference, effect on coverage and interference by power decrease, antenna height decrease

UNIT III**CELL COVERAGE FOR SIGNAL AND TRAFFIC:**

Signal reflections in flat and hilly terrain, effect of human made structures, phase difference between direct and reflected paths, constant standard deviation, straight line path loss slope, general formula for mobile propagation over water and flat open area, near and long distance propagation .

UNIT IV**CELL SITE AND MOBILE ANTENNAS :**

Space diversity antennas, umbrella pattern antennas, minimum separation of cell site antennas, Mobile Antennas.

Frequency Management And Channel Assignment : Numbering and grouping, setup access and paging channels ,channel assignments to cell sites and mobile units, channel sharing and borrowing, sectorization, overlaid cells, non fixed channel assignment

UNIT V**HANDOFFS:**

Handoff Initiation, types of handoff, delaying handoff, advantages of Handoff, power difference handoff, forced handoff, mobile assisted and soft handoff . Intersystem handoff.

TEXTBOOKS:

1. Mobile Cellular Telecommunications – W.C.Y. Lee, Tata McGraw Hill, 2nd Edn., 2006.
2. Wireless Communications - Theodore. S. Rappoport, Pearson education, 2nd Edn., 2002.

REFERENCES:

1. Principles of Mobile Communications – Gordon L. Stuber, Springer International 2nd Edition, 2001.
2. Modern Wireless Communication –Simon Haykin Michael Moher, Persons Eduction,2005.
3. Wireless Communication theory and Techniques,Asrar U.H .Sheikh ,Springer,2004.

OUTCOMES:

- The student will be able to understand impairments due to multipath fading channel
- The student will be able to understand the fundamental techniques to overcome the different fading effects
- The student will be able to understand co-channel and non co-channel interferences
- The student will be able to familiar with cell coverage/signal and traffic, diversity techniques and mobile antennas
- The student will be able to understand the frequency management, channel assignment and types of handoffs

CELLULAR MOBILE COMMUNICATIONS

UNIT-I(A)

INTRODUCTION TO CELLULAR SYSTEMS

LIMITATIONS OF CONVENTIONAL MOBILE TELEPHONE SYSTEMS

One of many reasons for developing a cellular mobile telephone system and deploying it in many cities is the operational limitations of conventional mobile telephone systems: limited service capability, poor service performance, and inefficient frequency spectrum utilization.

LIMITED SERVICE CAPABILITY:

A conventional mobile telephone system is usually designed by selecting one or more channels from a specific frequency allocation for use in autonomous geographic zones, as shown in Fig.1. The communications coverage area of each zone is normally planned to be as large as possible, which means that the transmitted power should be as high as the federal specification allows. The user who starts a call in one zone has to reinitiate the call when moving into a new zone because the call will be dropped. This is an undesirable radio telephone system since there is no guarantee that a call can be completed without a handoff capability. The handoff is a process of automatically changing frequencies as the mobile unit moves into a different frequency zone so that the conversation can be continued in a new frequency zone without redialing. Another disadvantage of the conventional system is that the number of active users is limited to the number of channels assigned to a particular frequency zone.

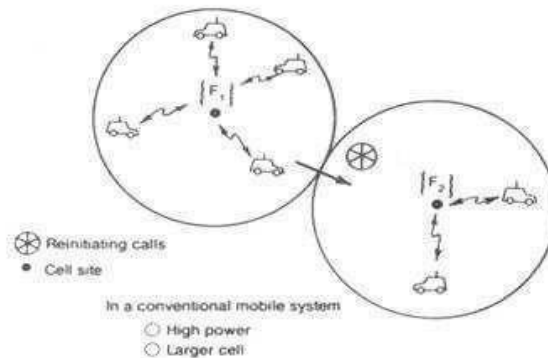

Fig.1 Conventional Mobile System

POOR SERVICE PERFORMANCE:

In the past, a total of 33 channels were all allocated to three mobile telephone systems: Mobile Telephone Service (MTS), Improved Mobile Telephone Service (IMTS) MJ systems, and Improved Mobile Telephone Service (IMTS) MK systems. MTS operates around 40 MHz and MJ operates at 150 MHz; both provide 11 channels; IMTS MK operates at 450 MHz and provides 12 channels. These 33 channels must cover an area 50 mi in diameter. In 1976,

CELLULAR MOBILE COMMUNICATIONS

New York City had 6 channels of MJ serving 320 customers, with another 2400 customers on a waiting list. New York City also had 6 channels of MK serving 225 customers, with another 1300 customers on a waiting list. The large number of subscribers created a high blocking probability during busy hours. Although service performance was undesirable, the demand was still great. A high-capacity system for mobile telephones was needed.

Inefficient Frequency Spectrum Utilization:

In a conventional mobile telephone system, the frequency utilization measurement M_o , is defined as the maximum number of customers that could be served by one channel at the busy hour.

M_o = Number of customers/channel

M_o = 53 for MJ

37 for MK

The offered load can then be obtained by

A = Average calling time (minutes) x total customers / 60 min (Erlangs)

Assume average calling time = 1.76 min.

$A_1 = 1.76 * 53 * 6 / 60 = 9.33$ Erlangs (MJ system)

$A_2 = 1.76 * 37 * 6 / 60 = 6.51$ Erlangs (MK system)

If the number of channels is 6 and the offered loads are $A_1 = 9.33$ and $A_2 = 6.51$, then from the Erlang B model the blocking probabilities, $B_1 = 50$ percent (MJ system) and $B_2 = 30$ percent (MK system), respectively. It is likely that half the initiating calls will be blocked in the MJ system, a very high blocking probability. As far as frequency spectrum utilization is concerned the conventional system does not utilize the spectrum efficiently since each channel can only serve one customer at a time in a whole area. This is overcome by the new cellular system.

BASIC CELLULAR SYSTEMS

A basic analog cellular system consists of three subsystems: a mobile unit, a cell site, and a mobile telephone switching office (MTSO), as Fig. 1.1 shows, with connections to link the three subsystems.

Mobile units: A mobile telephone unit contains a control unit, a transceiver, and an antenna system.

Cell site: The cell site provides interface between the MTSO and the mobile units. It has a control unit, radio cabinets, antennas, a power plant, and data terminals.

MTSO: The switching office, the central coordinating element for all cell sites, contains the cellular processor and cellular switch. It interfaces with telephone company zone offices, controls call processing, provides operation and maintenance, and handles billing activities.

Connections: The radio and high-speed data links connect the three subsystems. Each mobile unit can only use one channel at a time for its communication link. But the channel is not fixed; it can be any one in the entire band

CELLULAR MOBILE COMMUNICATIONS

assigned by the serving area, with each site having multichannel capabilities that can connect simultaneously to many mobile units.

The MTSO is the heart of the analog cellular mobile system. Its processor provides central coordination and cellular administration. The cellular switch, which can be either analog or digital, switches calls to connect mobile subscribers to other mobile subscribers and to the nationwide telephone network. It uses voice trunks similar to telephone company interoffice voice trunks. It also contains data links providing supervision links between the processor and the switch and between the cell sites and the processor. The radio link carries the voice and signaling between the mobile unit and the cell site. The high-speed data links cannot be transmitted over the standard telephone trunks and therefore must use either microwave links or T-carriers (wire lines). Microwave radio links or T-carriers carry both voice and data between cell site and the MTSO.

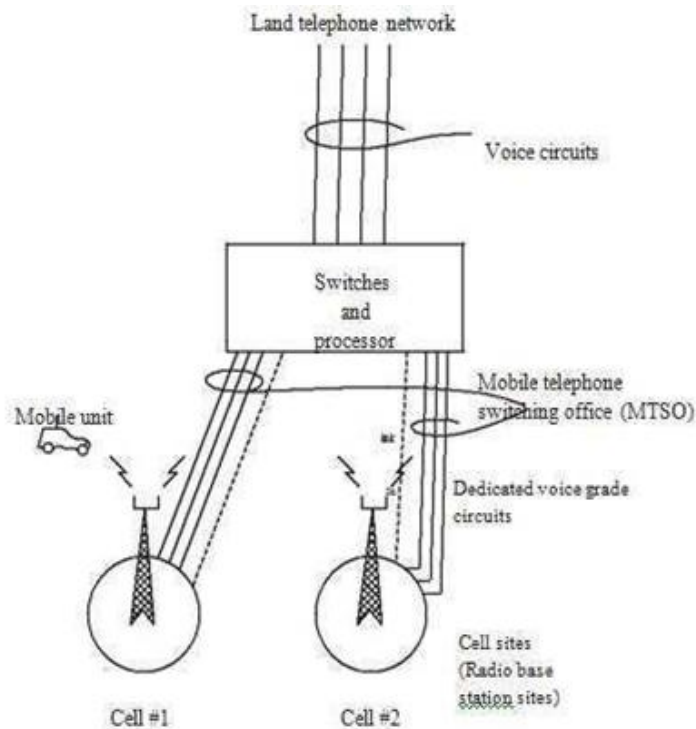

Fig: Basic cellular system

FIRST, SECOND, THIRD, AND FOURTH GENERATION CELLULAR WIRELESS SYSTEMS (1G, 2G, 3G AND 4G NETWORKS)

The "G" in wireless networks refers to the "generation" of the underlying wireless network technology. Technically generations are defined as follows:

1G networks (NMT, C-Nets, AMPS, TACS) are considered to be the first analog cellular systems, which started early 1980s. There were radio telephone systems even before that. 1G networks were conceived and designed purely for voice calls with almost no consideration of data services

CELLULAR MOBILE COMMUNICATIONS

2G networks (GSM, CDMAOne, D-AMPS) are the first digital cellular systems launched early 1990s, offering improved sound quality, better security and higher total capacity. GSM supports circuit-switched data (CSD), allowing users to place dial-up data calls digitally, so that the network's switching station receives actual ones and zeroes rather than the screech of an analog modem. 2G networks with theoretical data rates up to about 144kbit/s.

3G networks (UMTS FDD and TDD, CDMA2000 1x EVDO, CDMA2000 3x, TD-SCDMA, Arrib WCDMA, EDGE, IMT-2000 DECT) are newer cellular networks that have data rates of 384kbit/s and more. The UN's International Telecommunications Union IMT-2000 standard requires stationary speeds of 2Mbps and mobile speeds of 384kpbs for a 3G.

4G technology refers to the fourth generation of mobile phone communication standards. LTE and WiMAX are marketed as parts of this generation, even though they fall short of the actual standard.

The ITI has taken ownership of 4G, bundling into a specification known as IMT-Advanced. The document calls for 4G technologies to deliver downlink speeds of 1Gbps when stationary and 100Mbps when mobile

UNIQUENESS OF MOBILE RADIO ENVIRONMENT

DESCRIPTION OF MOBILE RADIO TRANSMISSION MEDIUM

THE PROPAGATION ATTENUATION.

In general, the propagation path loss increases not only with frequency but also with distance. If the antenna height at the cell site is 30 to 100 m and at the mobile unit about 3 m above the ground, and the distance between the cell site and the mobile unit is usually 2 km or more, then the incident angles of both the direct wave and the reflected wave are very small, as Fig. 2.4 shows. The incident angle of the direct wave is θ_1 , and the incident angle of the reflected wave is θ_2 . θ_1 is also called the elevation angle. The propagation path loss would be 40 dB/dec, where "dec" is an abbreviation of *decade*, i.e., a period of 10. This means that a 40-dB loss at a signal receiver will be observed by the mobile unit as it moves from 1 to 10 km. Therefore C is inversely proportional to R .

4

$$C \propto R^{-4} = \alpha R^{-4} \quad (2.3-1)$$

Where C = received carrier power

R = distance measured from the transmitter to

the receiver α = constant

CELLULAR MOBILE COMMUNICATIONS

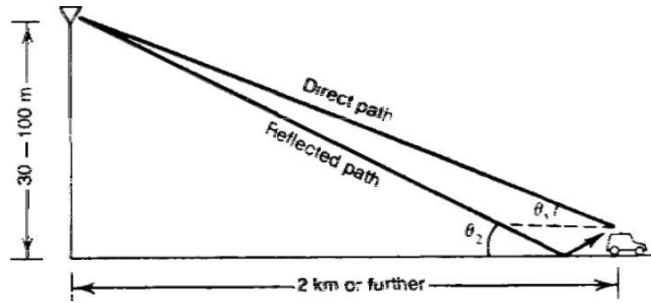

FIGURE 2.4 mobile radio transmission models.

The difference in power reception at two different distances R_1 and R_2 will result in

$$\frac{C_2}{C_1} = \left(\frac{R_2}{R_1}\right)^{-4} \quad (2.3-2a)$$

and the decibel expression of Eq. (2.3-2a) is

$$\begin{aligned} \Delta C \text{ (in dB)} &= C_2 - C_1 \text{ (in dB)} \\ &= 10 \log \frac{C_2}{C_1} = 40 \log \frac{R_1}{R_2} \end{aligned} \quad (2.3-2b)$$

When $R_2 = 2R_1$, $\Delta C = -12$ dB; when $R_2 = 10R_1$, $\Delta C = -40$ dB.

This 40 dB/dec is the general rule for the mobile radio environment and is easy to remember. It is also easy to compare to the free-space propagation rule of 20 dB/dec. The linear and decibel scale expressions are

$$C \propto R^{-2} \quad (\text{free space}) \quad (2.3-3a)$$

and

$$\begin{aligned} \Delta C &= C_2 \text{ (in dB)} - C_1 \text{ (in dB)} \\ &= 20 \log \frac{R_1}{R_2} \quad (\text{free space}) \end{aligned} \quad (2.3-3b)$$

In a real mobile radio environment, the propagation path-loss slope varies as

$$\begin{aligned} C &\propto R^{-\gamma} \\ &= \alpha R^{-\gamma} \end{aligned} \quad (2.3-4)$$

γ usually lies between 2 and 5 depending on the actual conditions.⁵ Of course, γ cannot be lower than 2, which is the free-space condition.

The decibel scale expression of Eq. (2.3-4) is

$$C = 10 \log \alpha - 10\gamma \log R \text{ dB} \quad (2.3-5)$$

SEVERE FADING. Because the antenna height of the mobile unit is lower than its typical surroundings, and the carrier frequency wavelength is much less than the sizes of the surrounding structures, multipath waves are generated. At the mobile unit, the sum of the multipath waves causes a signal-fading phenomenon. The signal

CELLULAR MOBILE COMMUNICATIONS

fluctuates in a range of about 40 dB (10 dB above and 30 dB below the average signal). We can visualize the nulls of the fluctuation at the baseband at about every half wavelength in space, but all nulls do not occur at the same level, as Fig. 2.5 shows. If the mobile unit moves fast, the rate of fluctuation is fast. For instance, at 850 MHz, the wavelength is roughly 0.35 m (1 ft). If the speed of the mobile unit is 24 km/h (15 mi/h), or 6.7 m/s, the rate of fluctuation of the signal reception at a 10-dB level below the average power of a fading signal is 15 nulls per second (see Sec. 2.3.3).⁶

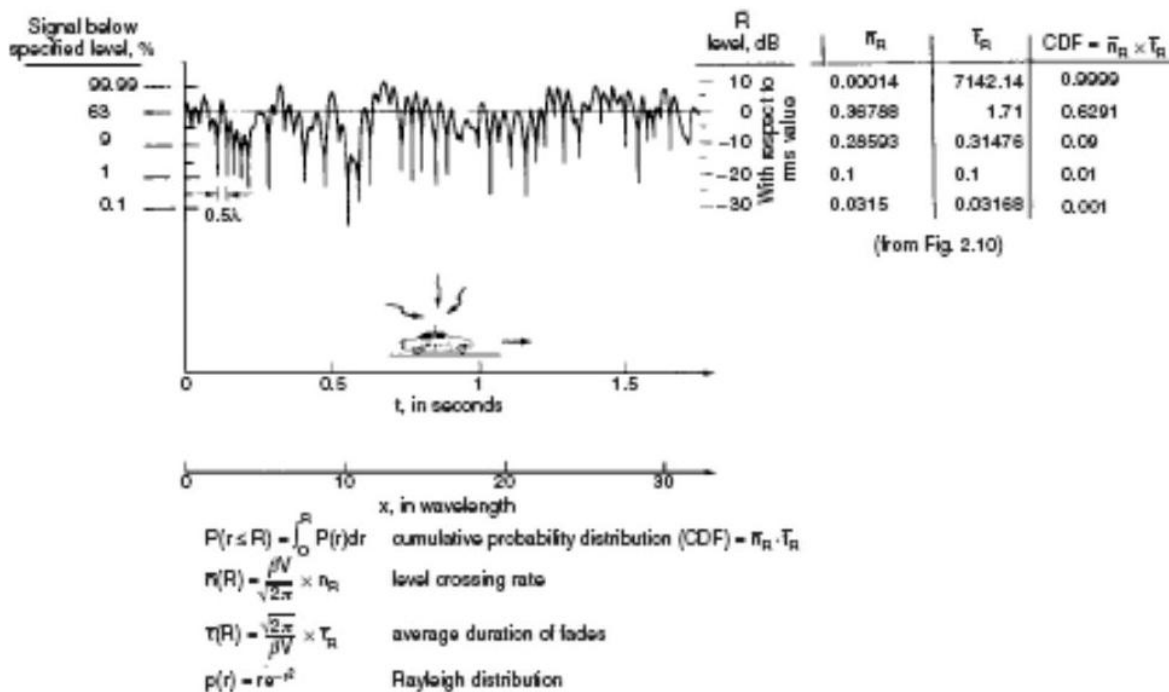

Fig: A typical fading signal while the mobile unit is moving

MODEL OF TRANSMISSION MEDIUM

A mobile radio signal $r(t)$, illustrated in Fig. 2.6, can be artificially characterized⁵ by two components $m(t)$ and $r_0(t)$ based on natural physical phenomena.

$$r(t) = m(t)r_0(t) \quad (2.3-6)$$

The component $m(t)$ is called *local mean, long-term fading, or lognormal fading* and its variation is due to the terrain contour between the base station and the mobile unit. The factor r_0 is called *multipath fading, short-term fading, or Rayleigh fading* and its variation is due to the waves reflected from the surrounding buildings and other structures. The long-term fading $m(t)$ can be obtained from Eq. (2.3-7a).

CELLULAR MOBILE COMMUNICATIONS

$$m(t_1) = \frac{1}{2T} \int_{t_1-T}^{t_1+T} r(t) dt \quad (2.3-7a)$$

where $2T$ is the time interval for averaging $r(t)$. T can be determined based on the fading rate of $r(t)$, usually 40 to 80 fades.⁵ Therefore, $m(t)$ is the envelope of $r(t)$, as shown in Fig.2.6a.

Equation (2.3-7a) also can be expressed in spatial scale as

$$m(x_1) = \frac{1}{2L} \int_{x_1-L}^{x_1+L} r(x) dx \quad (2.3-7b)$$

The length of $2L$ has been determined to be 20 to 40 wavelengths. Using 36 or up to 50 samples in an interval of 40 wavelengths is an adequate averaging process for obtaining the local means.

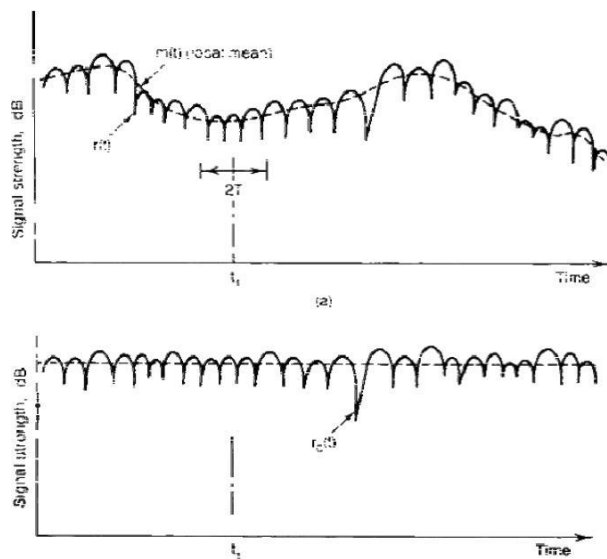

FIGURE 2.6 A mobile radio signal fading representation. (A) A mobile signal fading. (B) short-term signal fading.

The factor $m(t)$ or $m(x)$ is also found to be a log-normal distribution based on its characteristics caused by the terrain contour. The short-term fading r_0 is obtained by

$$r_0 \text{ (in dB)} = r(t) - m(t) \text{ dB} \quad (2.3-8)$$

as shown in Fig. 2.6b. The factor $r_0(t)$ follows a Rayleigh distribution, assuming that only reflected waves from local surroundings are the ones received (a normal situation for the mobile radio environment). Therefore, the term *Rayleigh fading* is often used.

CELLULAR MOBILE COMMUNICATIONS

DIRECT WAVE PATH, LINE-OF-SIGHT PATH, AND OBSTRUCTIVE PATH

A **direct wave path** is a path clear from the terrain contour.

The **line-of-sight path** is a path clear from buildings. In the mobile radio environment, we do not always have a line-of-sight condition.

When the terrain contour blocks the direct wave path, we call it the **obstructive path**.

AMPLIFIER NOISE

A mobile radio signal received by a receiving antenna, either at the cell site or at the mobile unit, will be amplified by an amplifier. We would like to understand how the signal is affected by the amplifier noise. Assume that the amplifier has an available power gain g and the available noise power at the output is N_o . The input signal-to-noise (S/N) ratio is P_s/N_i , the output signal-to-noise ratio is P_o/N_o , and the internal amplifier noise is N_α . Then the output P_o/N_o becomes

$$\frac{P_o}{N_o} = \frac{g P_s}{g(N_i) + N_\alpha} = \frac{P_s}{N_i + (N_\alpha/g)} \quad (2.3-20)$$

The noise figure F is defined as

$$F = \frac{\text{maximum possible S/N ratio}}{\text{actual S/N ratio at output}} \quad (2.3-21)$$

where the maximum possible S/N ratio is measured when the load is an open circuit.

Equation (2.3-21) can be used for obtaining the noise figure of the amplifier.

$$F = \frac{P_s/kTB}{P_o/N_o} = \frac{N_o}{(P_o/P_s)kTB} = \frac{N_o}{g(kTB)} \quad (2.3-22)$$

Also substituting Eq. (2.3-20) into Eq. (2.3-22) yields

$$F = \frac{P_s/kTB}{P_s/[N_i + (N_\alpha/g)]} = \frac{N_i + (N_\alpha/g)}{kTB} \quad (2.3-23)$$

The term kTB is the thermal noise. The noise figure is a reference measurement between a minimum noise level due to thermal noise and the noise level generated by both the external and internal noise of an amplifier.

LONG-TERM FADING:

Long-term fading occurs when the propagation environment is changing significantly but this fading is typically much slower than short-term fading.

CELLULAR MOBILE COMMUNICATIONS

Long-term fading means slower variation in mean signal strength and is produced by movement over much longer distances.

Long-term is caused by terrain configuration (hill, flat area etc.), which results in local mean attenuation and fluctuation. Long term fading is also called as slow fading or shadowing.

FACTORS INFLUENCING SHORT TERM FADING:

The following physical factors influence short-term fading in the radio propagation channel:

(1) MULTIPATH PROPAGATION

Multipath is the propagation phenomenon that results in radio signals reaching the receiving antenna by two or more paths. The effects of multipath include constructive and destructive interference, and phase shifting of the signal.

(2) SPEED OF THE MOBILE

The relative motion between the base station and the mobile results in random frequency modulation due to different doppler shifts on each of the multipath components.

(3) SPEED OF SURROUNDING OBJECTS

If objects in the radio channel are in motion, they induce a time varying Doppler shift on multipath components. If the surrounding objects move at a greater rate than the mobile, then this effect dominates fading.

(4) TRANSMISSION BANDWIDTH OF THE SIGNAL

If the transmitted radio signal bandwidth is greater than the "bandwidth" of the multipath channel (quantified by coherence bandwidth), the received signal will be distorted.

PARAMETERS OF MOBILE MULTIPATH FADING:

To compare the different multipath channels and to quantify them, we define some parameters. They all can be determined from the power delay profile. These parameters can be broadly divided into two types.

Time Dispersion Parameters

These parameters include the mean excess delay, rms delay spread and excess delay spread. The mean excess delay is the first moment of the power delay profile and is defined as

$$\bar{\tau} = \frac{\sum a_k^2 \tau_k}{\sum a_k^2} = \frac{\sum P(\tau_k) \tau_k}{\sum P(\tau_k)}$$

where a_k is the amplitude, τ_k is the excess delay and $P(\tau_k)$ is the power of the individual multipath signals.

The mean square excess delay spread is defined as

$$\bar{\tau}^2 = \frac{\sum P(\tau_k) \tau_k^2}{\sum P(\tau_k)}$$

Since the rms delay spread is the square root of the second central moment of the power delay profile, it can be written as

$$\sigma_\tau = \sqrt{\bar{\tau}^2 - (\bar{\tau})^2}$$

COHERENCE BANDWIDTH:

Coherence bandwidth is a statistical measure of the range of frequencies over which the channel can be considered to pass all the frequency components with almost equal gain and linear phase. When this condition is satisfied then we say the channel to be flat.

Practically, coherence bandwidth is the minimum separation over which the two frequency components are affected differently. If the coherence bandwidth is considered to be the bandwidth over which the frequency correlation function is above 0.9, then it is approximated as

$$B_C \approx \frac{1}{50\sigma_\tau}$$

However, if the coherence bandwidth is considered to be the bandwidth over which the frequency correlation function is above 0.5, then it is defined as

$$B_C \approx \frac{1}{5\sigma_\tau}$$

Doppler Spread (B_d), Coherence Time (T_c)

RMS delay spread σ_τ and coherence bandwidth B_c are parameters which describe the time dispersive nature of the channel in a local area and they do not offer any information about the time varying nature of the channel due to the relative motion between the mobile station and base station.

Doppler Spread B_d is a measure of the spectral broadening caused by the time rate of change of the mobile radio channel and is defined as the range of frequencies over which the received Doppler spectrum is essentially non-zero. In other words, if the baseband signal bandwidth is much greater than B_d , the effects of Doppler spread are negligible at the receiver. This is also called slow fading.

Coherence time T_c is the time domain dual of Doppler spread and is used to characterize the time varying nature of the frequency dispersiveness of the channel in the time domain. The Doppler spread and coherence time are inversely proportional to

one another: $T_c = \frac{1}{B_d}$.

Types of small scale fading

From the discussion above, we know that the type of fading experienced by a signal propagating through a mobile radio channel depends on the nature of the transmitted signal with respect to the characteristics of the channel. Depending on the relation between the signal parameters (such as bandwidth, symbol period, etc) and the channel parameter (such as RMS delay spread and Doppler spread), different transmitted signals will undergo different types of fading. The time dispersion and frequency dispersion mechanisms in a mobile radio channel lead to four possible distinct effects, which are manifested depending on the nature of the transmitted signal, the channel, and the velocity. We will discuss them one by one below.

1. Flat Fading

If the mobile radio channel has a constant gain and linear phase response over a bandwidth which is greater than the bandwidth of the transmitted signal, which means

$$B_s \ll B_c \quad \text{or} \quad T_s \gg \sigma_\tau$$

Then the received signal will undergo flat fading. In flat fading, the multipath structure of the channel is such that the spectral characteristics of the transmitted signal are preserved at the receiver. However the strength of the received signal changes with time, due to fluctuations in the gain of the channel caused by multipath.

2. Frequency Selective Fading

If the channel possesses a constant-gain and linear phase response over a bandwidth that is smaller than the bandwidth of transmitted signal, the channel creates frequency selective fading on the received signal, which means

$$B_s > B_c \quad \text{or} \quad T_s < \sigma_\tau$$

Under such conditions the channel impulse response has a multipath delay spread which is greater than the reciprocal bandwidth of the transmitted message waveform. When it occurs, the received signal includes multiple versions of the transmitted waveform that are attenuated and delayed, and hence the received signal is distorted.

3. Fast Fading

In a fast fading channel, the channel impulse response changes rapidly within the symbol duration. That is, the coherence time of the channel is smaller than the symbol period of the transmitted signal. Viewed in the frequency domain, signal distortion due to fast fading increases with increasing Doppler spread relative to the bandwidth of the transmitted signal. Therefore, a signal undergoes fast fading if

$$T_s > T_c \quad \text{or} \quad B_s < B_d$$

4. Slow Fading

In a slow fading channel, the channel impulse response changes at a rate much slower than the transmitted baseband signal $S(t)$. In the frequency domain, this implies that the Doppler spread of the channel is much less than the bandwidth of the baseband signal. Therefore, a signal undergoes slow fading if

$$T_s \ll T_c \quad \text{or} \quad B_s \gg B_d$$

It should be clear that the velocity of the mobile (or velocity of objects in the channel) and the baseband signaling determine whether a signal undergoes fast fading or slow fading.

UNIT-I (B)

FUNDAMENTALS OF CELLULAR RADIO SYSTEM DESIGN

CONCEPT OF FREQUENCY REUSE CHANNELS:

A radio channel consists of a pair of frequencies one for each direction of transmission that is used for full-duplex operation. Particular radio channels, say F_1 , used in one geographic zone to call a cell, say C_1 , with a coverage radius R can be used in another cell with the same coverage radius at a distance D away.

Frequency reuse is the core concept of the cellular mobile radio system. In this frequency reuse system users in different geographic locations (different cells) may simultaneously use the same frequency channel (see Fig.1.). The frequency reuse system can drastically increase the spectrum efficiency, but if the system is not properly designed, serious interference may occur. Interference due to the common use of the same channel is called co-channel interference and is our major concern in the concept of frequency reuse.

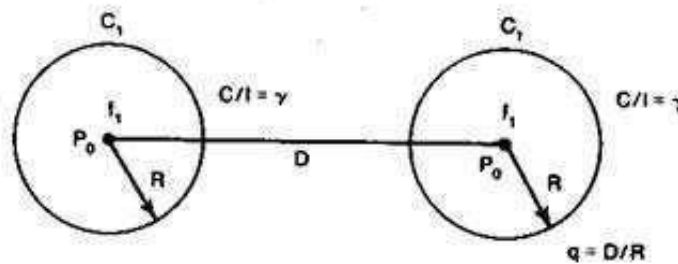
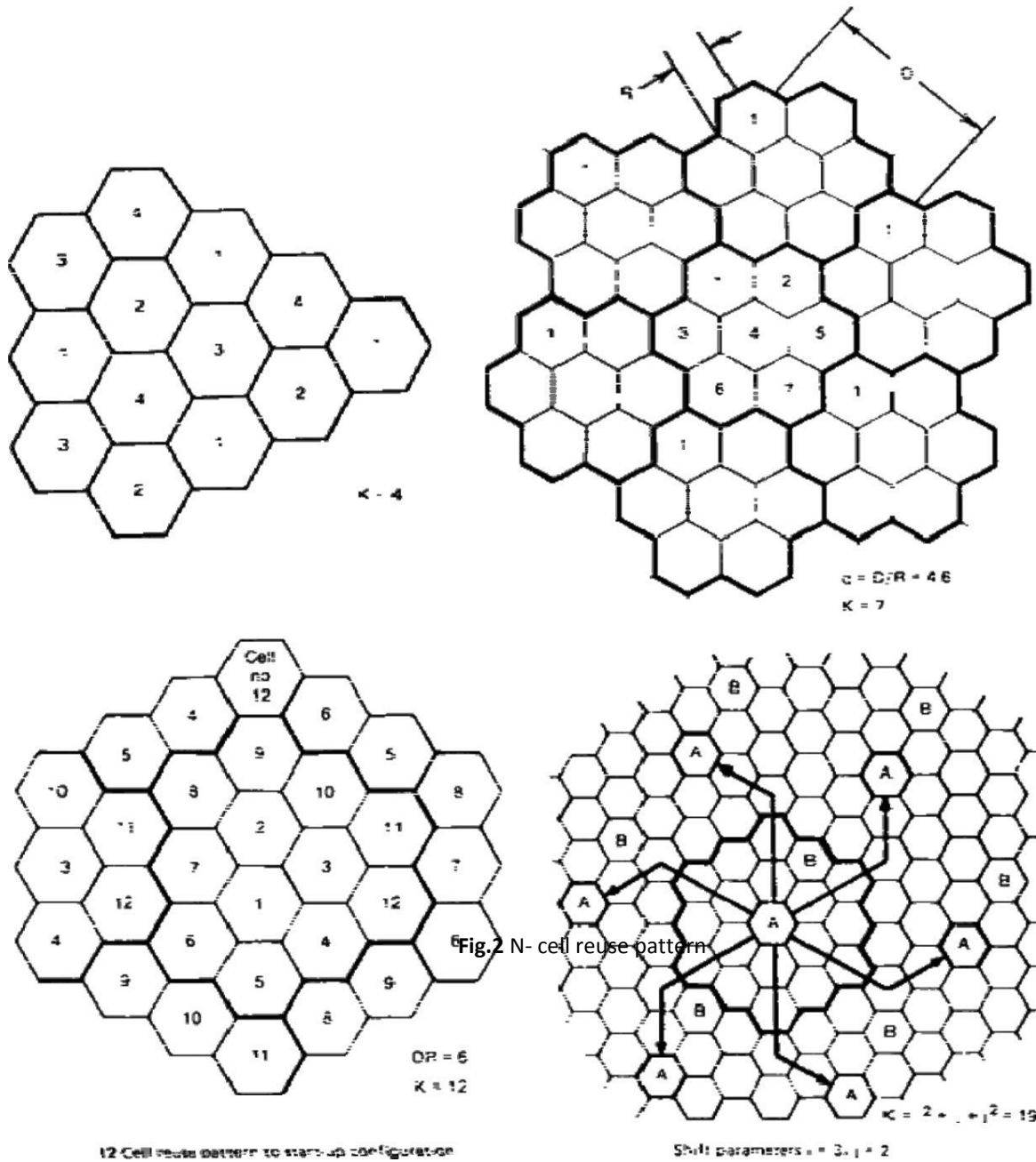

Fig.1 The ratio of D/R

FREQUENCY REUSE SCHEME: The frequency reuse concept can be used in the time domain and the space domain. Frequency reuse in the time domain results in the occupation of the same frequency in different time slots. It is called time division multiplexing (TDM). Frequency reuse in the space domain can be divided into two categories.

1. Same frequency assigned in two different geographic areas, such as A.M or FM radio stations using the same frequency in different cities.
2. Same frequency repeatedly used in a same general area in one system - the scheme is used in cellular systems. There are many co-channel cells in the system. The total frequency spectrum allocation is divided into K frequency reuse patterns, as illustrated in Fig. 2 for $K = 4, 7, 12,$ and 19 .



Frequency reuses distance:

The minimum distance which allows the same frequency to be reused will depend on many factors, such as the number of co-channel cells in the vicinity of the center cell, the type of geographical terrain contour, the antenna height and the transmitted power at each cell site. The frequency reuse distance can be determined from Where K is the frequency reuse pattern shown in Fig.3, then

CELLULAR MOBILE COMMUNICATIONS

$$D = \begin{cases} 3.46R & K = 4 \\ 4.6R & K = 7 \\ 6R & K = 12 \\ 7.55R & K = 19 \end{cases}$$

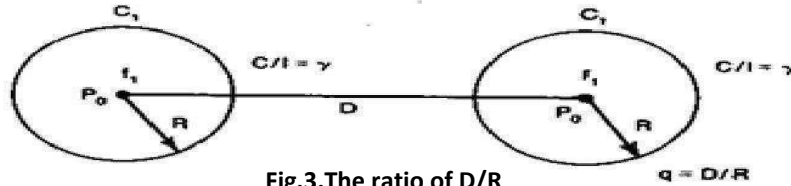

If all the cell sites transmit the same power, then K increases and the frequency reuse distance D increases. This increased D reduces the chance that cochannel interference may occur.

Theoretically, a large K is desired. However, the total number of allocated channels is fixed. When K is too large, the number of channels assigned to each of K cells becomes small. It is always true that if the total number of channels in K cells is divided as K increases, trunking inefficiency results. The same principle applies to spectrum inefficiency: if the total numbers of channels are divided into two network systems serving in the same area, spectrum inefficiency increases.

Obtaining the smallest number K involves estimating cochannel interference and selecting the minimum frequency reuse distance D to reduce cochannel interference. The smallest value of K is K = 3, obtained by setting i = 1, j = 1 in the equation $K = i^2 + ij + j^2$.

CO-CHANNEL INTERFERENCE REDUCTION FACTOR

Reusing an identical frequency channel in different cells is limited by cochannel interference between cells, and the cochannel interference can become a major problem.

Assume that the size of all cells is roughly the same. The cell size is determined by the coverage area of the signal strength in each cell. As long as the cell size is fixed, cochannel interference is independent of the transmitted power of each cell. It means that the received threshold level at the mobile unit is adjusted to the size of the cell. Actually, cochannel interference is a function of a parameter q defined as

$$q = D/R$$

The parameter q is the cochannel interference reduction factor. When the ratio q increases, cochannel interference decreases. Furthermore, the separation D is a function of K, and C/I,

$$D=f(K,C/I)$$

Where K, is the number of cochannel interfering cells in the first tier and C/I is the received carrier-to-interference ratio at the desired mobile receiver.

$$\frac{C}{I} = \frac{C}{\sum_{k=1}^{K_i} I_k}$$

CELLULAR MOBILE COMMUNICATIONS

In a fully equipped hexagonal-shaped cellular system, there are always six cochannel interfering cells in the first tier, as shown in Fig.5 ; that is, $K = 6$. The maximum number of K , in the first tier can be shown as six. Cochannel interference can be experienced both at the cell site and at mobile units in the center cell. If the interference is much greater, then the carrier-to-interference ratio C/I at the mobile units caused by the six interfering sites is (on the average) the same as the C/I received at the center cell site caused by interfering mobile units in the six cells. According to both the reciprocity theorem and the statistical summation of radio propagation, the two C/I values can be very close. Assume that the local noise is much less than the interference level and can be neglected. C/I then can be expressed as

$$\frac{C}{I} = \frac{R^{-\gamma}}{\sum_{k=1}^{K_I} D_k^{-\gamma}}$$

Where γ is a propagation path-loss slope determined by the actual terrain environment. In a mobile radio medium,

γ Usually is assumed to be 4. K is the number of co-channel interfering cells and is equal to 6 in a fully developed system, as shown in Fig. 5. The six co-channel interfering cells in the second tier cause weaker interference than those in the first tier. Therefore, the co-channel interference from the second tier of interfering cells is negligible

$$\frac{C}{I} = \frac{1}{\sum_{k=1}^{K_I} \left(\frac{D_k}{R}\right)^{-\gamma}} = \frac{1}{\sum_{k=1}^{K_I} (q_k)^{-\gamma}}$$

Where q_k is the cochannel interference reduction factor with K th co-channel interfering cell

$$q_k = \frac{D_k}{R}$$

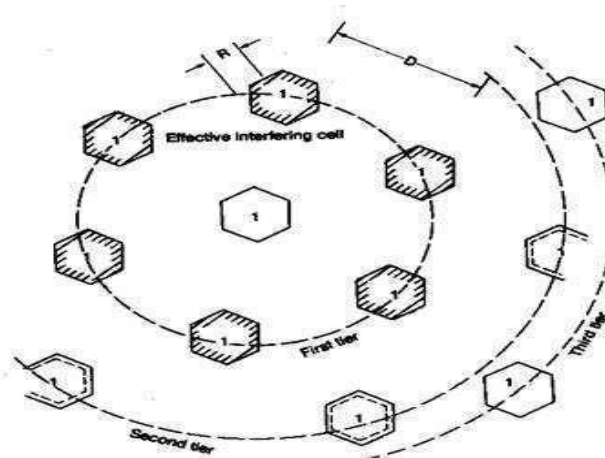

Fig 5: Six effective interfering cells of cell 1

CELLULAR MOBILE COMMUNICATIONS

C/I FOR NORMAL CASE IN AN OMNI DIRECTIONAL ANTENNA SYSTEM.

There are two cases to be considered: (1) the signal and co-channel interference received by the mobile unit and (2) the signal and co-channel interference received by the cell site. Both cases are shown in Fig.6. N_m and N_b are the local noises at the mobile unit and the cell site, respectively. Usually N_m and N_b are small and can be neglected as compared with the interference level. As long as the received carrier-to-interference ratios at both the mobile unit and the cell site are the same, the system is called a balanced system. In a balanced system, we can choose either one of the two cases to analyze the system requirement; the results from one case are the same for the others.

Assume that all D_k are the same for simplicity, then $D = D_k$ and $q = q_k$,

$$\frac{C}{I} = \frac{R^{-\gamma}}{6D^{-\gamma}} = \frac{q^\gamma}{6}$$

Thus

$$q^\gamma = 6 \frac{C}{I}$$

And

$$q = \left(6 \frac{C}{I}\right)^{1/\gamma}$$

The value of C/I is based on the required system performance and the specified value of q is based on the terrain environment. With given values of C/I and γ , the co-channel interference reduction factor q can be determined. Normal cellular practice is to specify C/I to be 18 dB or higher based on subjective tests. Since a C/I of 18 dB is measured by the acceptance of voice quality from present cellular mobile receivers, this acceptance implies that both mobile radio multipath fading and co-channel interference become ineffective at that level. The path-loss slope is equal to about 4 in a mobile radio environment.

$$q = D/R = (6 \times 63.1)^{1/4} = \underline{4.41}$$

The 90th percentile of the total covered area would be achieved by increasing the transmitted power at each cell; increasing the same amount of transmitted power in each cell does not affect the result. This is because q is not a function of transmitted power. The factor q can be related to the finite set of cells K in a hexagonal-shaped cellular system by

$$q = \frac{\Delta}{\sqrt{3K}}$$

Substituting $q = 4.41$ in above equation yields $k=7$.

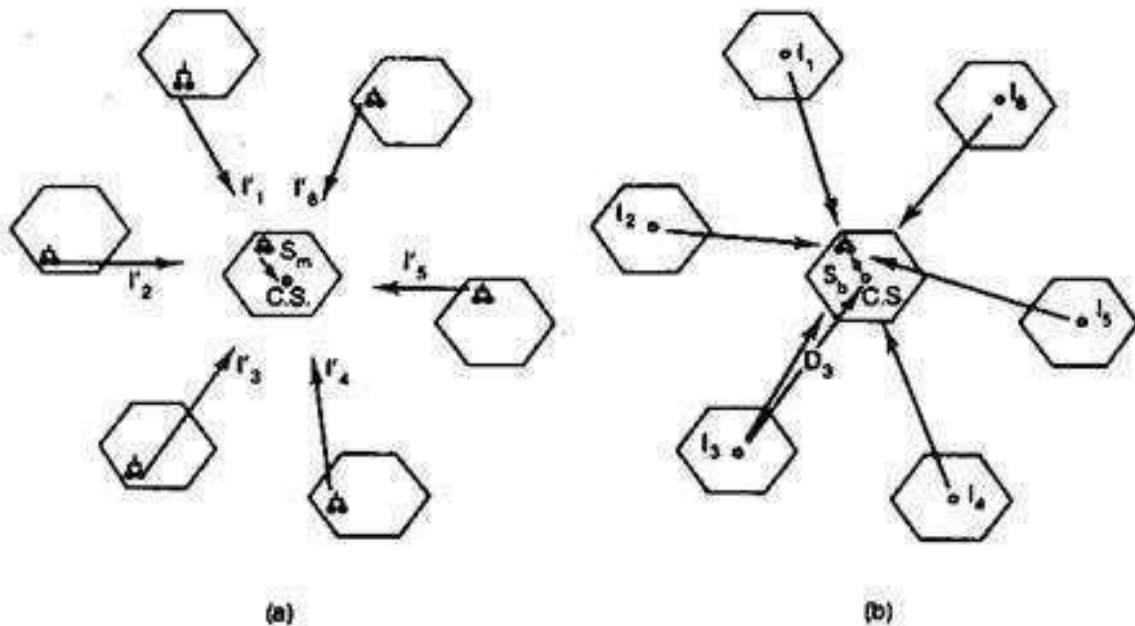

Fig 6 Cochannel interference from six interferers. (a).receiving at the cell site; (b) receiving at the mobile unit.

TRUNKING AND GRADE OF SERVICE

Cellular radio systems rely on *trunking* to accommodate a large number of users in a limited radio spectrum. The concept of trunking allows a large number of users to share the relatively small number of channels in a cell by providing access to each user, on demand, from a pool of available channels. In a trunked radio system, each user is allocated a channel on a per call basis, and upon termination of the call, the previously occupied channel is immediately returned to the pool of available channels.

Trunking exploits the statistical behavior of users so that a fixed number of channels or circuits may accommodate a large, random user community. The telephone company uses trunking theory to determine the number of telephone circuits that need to be allocated for office buildings with hundreds of telephones, and this same principle is used in designing cellular radio systems. There is a trade-off between the number of available telephone circuits and the likelihood of a particular user finding that no circuits are available during the peak calling time. As the number of phone lines decreases, it becomes more likely that all circuits will be busy for a particular user. In a trunked mobile radio system, when a particular user requests service and all of the radio channels are already in use, the user is blocked, or denied access to the system. In some systems, a queue may be used to hold the requesting users until a channel becomes available.

CELLULAR MOBILE COMMUNICATIONS

To design trunked radio systems that can handle a specific capacity at a specific “grade of service,” it is essential to understand trunking theory and queuing theory. The fundamentals of trunking theory were developed by Erlang, a Danish mathematician who, in the late 19th century, embarked on the study of how a large population could be accommodated by a limited number of servers [Bou88]. Today, the measure of traffic intensity bears his name. One Erlang represents the amount of traffic intensity carried by a channel that is completely occupied (i.e., one call-hour per hour or one call-minute per minute). For example, a radio channel that is occupied for thirty minutes during an hour carries 0.5 Erlangs of traffic.

The *grade of service (GOS)* is a measure of the ability of a user to access a trunked system during the busiest hour. The busy hour is based upon customer demand at the busiest hour during a week, month, or year. The busy hours for cellular radio systems typically occur during rush hours, between 4 p.m. and 6 p.m. on a Thursday or Friday evening. The grade of service is a benchmark used to define the desired performance of a particular trunked system by specifying a desired likelihood of a user obtaining channel access given a specific number of channels available in the system. It is the wireless designer’s job to estimate the maximum required capacity and to allocate the proper number of channels in order to meet the *GOS*. *GOS* is typically given as the likelihood that a call is blocked, or the likelihood of a call experiencing a delay greater than a certain queuing time.

DEFINITIONS OF COMMON TERMS USED IN TRUNKING THEORY:

Set-Up Time: the time required to allocate a trunked radio channel to a requesting user.

Blocked Call: Call which cannot be completed at time of request, due to congestion. Also referred to as a lost call.

Holding Time: Average duration of a typical call. Denoted by H (in seconds).

Traffic Intensity: Measure of channel time utilization, which is the average channel occupancy measured in **ERLANGS**. This is dimensionless quantity and may be used to measure the time utilization of single or multiple channels. Denoted by A .

Load: Traffic intensity across the entire trunked radio system, measured in Erlangs.**Grade of Service(GOS):** A measure of congestion which is specified as the probability of a call being blocked (for Erlang B), or the probability of a call being delayed beyond a certain amount of time(for Erlang C).

REQUEST RATE: The average number of call requests per unit time.

A number of definitions listed in Table 3.3 are used in trunking theory to make capacity estimates in trunked systems.

The traffic intensity offered by each user is equal to the call request rate multiplied by the holding time. That is, each user generates a traffic intensity of A_u Erlangs given by

$$A_u = \lambda H \quad (3.13)$$

where H is the average duration of a call and λ is the average number of call requests per unit time for each user. For a system containing U users and an unspecified number of channels, the total offered traffic intensity A , is given as

$$A = UA_u \quad (3.14)$$

CELLULAR MOBILE COMMUNICATIONS

Furthermore, in a C channel trunked system, if the traffic is equally distributed among the channels, then the traffic intensity per channel, A_c , is given as

$$A_c = UA_u/C \quad (3.15)$$

Note that the offered traffic is not necessarily the traffic which is *carried* by the trunked system, only that which is *offered* to the trunked system. When the offered traffic exceeds the maximum capacity of the system, the carried traffic becomes limited due to the limited capacity (i.e. limited number of channels). The maximum possible carried traffic is the total number of channels, C , in Erlangs. The AMPS cellular system is designed for a GOS of 2% blocking. This implies that the channel allocations for cell sites are designed so that 2 out of 100 calls will be blocked due to channel occupancy during the busiest hour.

There are two types of trunked systems which are commonly used. The first type offers no queuing for call requests. That is, for every user who requests service, it is assumed there is no setup time and the user is given immediate access to a channel if one is available. If no channels are available, the requesting user is blocked without access and is free to try again later. This type of trunking is called *blocked calls cleared* and assumes that calls arrive as determined by a Poisson distribution. Furthermore, it is assumed that there are an infinite number of users as well as the following: (a) there are memoryless arrivals of requests, implying that all users, including blocked users, may request a channel at any time; (b) the probability of a user occupying a channel is exponentially distributed, so that longer calls are less likely to occur as described by an exponential distribution; and (c) there are a finite number of channels available in the trunking pool. This is known as an M/M/m/m queue, and leads to the derivation of the Erlang B formula (also known as the *blocked calls cleared* formula). The Erlang B formula determines the probability that a call is blocked and is a measure of the GOS for a trunked system which provides no queuing for blocked calls. The Erlang B formula is derived in Appendix A and is given by

$$Pr[\text{blocking}] = \frac{\frac{A^C}{C!}}{\sum_{k=0}^C \frac{A^k}{k!}} = GOS \quad (3.16)$$

where C is the number of trunked channels offered by a trunked radio system and A is the total offered traffic. While it is possible to model trunked systems with finite users, the resulting expressions are much more complicated than the Erlang B result, and the added complexity is not warranted for typical trunked systems which have users that outnumber available channels by orders of magnitude. Furthermore, the Erlang B formula provides a conservative estimate of the GOS, as the finite user results always predict a smaller likelihood of blocking. The capacity of a trunked radio system where blocked calls are lost is tabulated for various values of GOS and numbers of channels in Table 3.4.

Table 3.4 Capacity of an Erlang B System

Number of Channels C	Capacity (Erlangs) for GOS			
	= 0.01	= 0.005	= 0.002	= 0.001
2	0.153	0.105	0.065	0.046
4	0.869	0.701	0.535	0.439
5	1.36	1.13	0.900	0.762
10	4.46	3.96	3.43	3.09
20	12.0	11.1	10.1	9.41
24	15.3	14.2	13.0	12.2
40	29.0	27.3	25.7	24.5
70	56.1	53.7	51.0	49.2
100	84.1	80.9	77.4	75.2

The second kind of trunked system is one in which a queue is provided to hold calls which are blocked. If a channel is not available immediately, the call request may be delayed until a channel becomes available. This type of trunking is called *Blocked Calls Delayed*, and its mea-

sure of GOS is defined as the probability that a call is blocked after waiting a specific length of time in the queue. To find the GOS, it is first necessary to find the likelihood that a call is initially denied access to the system. The likelihood of a call not having immediate access to a channel is determined by the Erlang C formula derived in Appendix A

$$Pr[\text{delay} > 0] = \frac{A^C}{A^C + C! \left(1 - \frac{A}{C}\right) \sum_{k=0}^{C-1} \frac{A^k}{k!}} \quad (3.17)$$

If no channels are immediately available the call is delayed, and the probability that the delayed call is forced to wait more than t seconds is given by the probability that a call is delayed, multiplied by the conditional probability that the delay is greater than t seconds. The GOS of a trunked system where blocked calls are delayed is hence given by

$$\begin{aligned} Pr[\text{delay} > t] &= Pr[\text{delay} > 0] Pr[\text{delay} > t | \text{delay} > 0] \\ &= Pr[\text{delay} > 0] \exp(-(C - A)t/H) \end{aligned} \quad (3.18)$$

The average delay D for all calls in a queued system is given by

$$D = Pr[\text{delay} > 0] \frac{H}{C - A} \quad (3.19)$$

where the average delay for those calls which are queued is given by $H/(C - A)$.

CELLULAR MOBILE COMMUNICATIONS

IMPROVING COVERAGE AND CAPACITY IN CELLULAR SYSTEMS

As the demand for wireless service increases, the number of channels assigned to a cell eventually becomes insufficient to support the required number of users. At this point, cellular design techniques are needed to provide more channels per unit coverage area. Techniques such as *cell splitting*, *sectoring*, and *coverage zone approaches* are used in practice to expand the capacity of cellular systems. Cell splitting allows an orderly growth of the cellular system. Sectoring uses directional antennas to further control the interference and frequency reuse of channels. The *zone microcell* concept distributes the coverage of a cell and extends the cell boundary to hard-to-reach places. While cell splitting increases the number of base stations in order to increase capacity, sectoring and zone microcells rely on base station antenna placements to improve capacity by reducing co-channel interference. Cell splitting and zone microcell techniques do not suffer the trunking inefficiencies experienced by sectored cells, and enable the base station to oversee all handoff chores related to the microcells, thus reducing the computational load at the MSC. These three popular capacity improvement techniques will be explained in detail.

CELL SPLITTING

The motivation behind implementing a cellular mobile system is to improve the utilization of spectrum efficiency. The frequency reuse scheme is one concept, and cell splitting is another concept. When traffic density starts to build up and the frequency channels F_i in each cell C_i cannot provide enough mobile calls, the original cell can be split into smaller cells. Usually the new radius is one-half the original radius. There are two ways of splitting: In Fig. 8 a, the original cell site is not used, while in Fig. 8 b, it is

$$\text{New cell radius} = \text{Old cell radius}/2$$

Then,

$$\text{New cell area} = \text{Old cell area}/4$$

Let each new cell carry the same maximum traffic load of the old cell, then

$$\text{New traffic load/Unit area} = 4 \times \text{Traffic load/Unit area}.$$

There are two kinds of cell-splitting techniques:

1. PERMANENT SPLITTING: The installation of every new split cell has to be planned ahead of time; the number of channels, the transmitted power, the assigned frequencies, the choosing of the cell-site selection, and the traffic load consideration should all be considered. When ready, the actual service cut-over should be set at the lowest traffic point, usually at midnight on a weekend. Hopefully, only a few calls will be dropped because of this cut-over, assuming that the downtime of the system is within 2h.

2. DYNAMIC SPLITTING: This scheme is based on using the allocated spectrum efficiency in real time. The algorithm for dynamically splitting cell sites is a tedious job, as we cannot afford to have one single cell unused during cell splitting at heavy traffic hours.

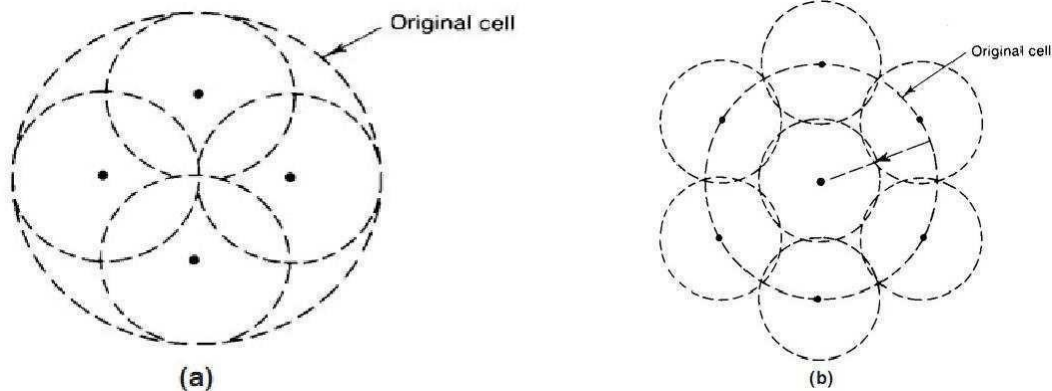

Fig.8 Cell splitting

SECTORING

Cell splitting achieves capacity improvement by essentially rescaling the system. By decreasing the cell radius R and keeping the co-channel reuse ratio D/R unchanged, cell splitting increases the number of channels per unit area.

However, another way to increase capacity is to keep the cell radius unchanged and seek methods to decrease a D/R ratio. as we now show sectoring increases SIR so that the cluster size may be reduced

In this approach. First the SIR is improved using directional antennas, then capacity improvement is achieved by reducing the no of cells in a cluster, thus increasing the frequency reuse. However in order to do this successfully. It is necessary to reduce the relative interference without decreasing the transmitted power.

The co-channel interference in a cellular systems may be decreased by replacing a single Omni directional antenna at the base station by several directional antennas each radiating within a specified sector. By using directional antennas, a given cell will receive interference and transmit with only a fraction of the available co-channel cells. The technique for decreasing co-channel interference and thus increasing system performance by using directional antennas is called sectoring. The factor by which the co-channel interference is reduced depends on the amount of sectoring used. A cell is normally partitioned into three 120° sectors or six 60° sectors as shown in below figure.

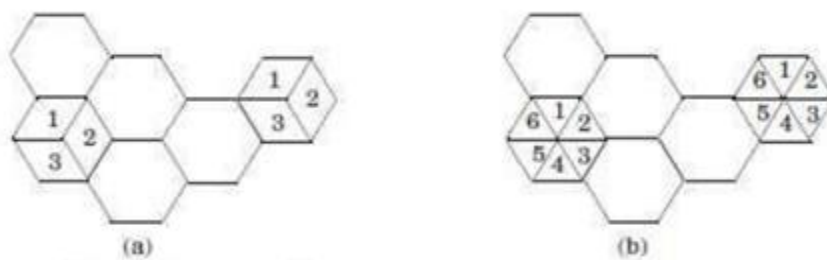

Fig: (a) 120° sectoring (b) 60° sectoring

CELLULAR MOBILE COMMUNICATIONS

MICROCELL ZONE CONCEPT

The increased number of handoffs required when sectoring is employed results in an increased load on the switching and control link elements of the mobile system. A solution to this problem was presented by Lee. The proposal is based on a microcell concept for seven cell reuse as illustrated in fig below. In this scheme, each of the three (or possibly more) zone sites

(represented as Tx/Rx in Figure 3.13) are connected to a single base station and share the same radio equipment. The zones are connected by coaxial cable, fiberoptic cable, or microwave link to the base station. Multiple zones and a single base station make up a cell. As a mobile travels within the cell, it is served by the zone with the strongest signal. This approach is superior to sectoring since antennas are placed at the outer edges of the cell, and any base station channel may be assigned to any zone by the base station.

As a mobile travels from one zone to another within the cell, it retains the same channel. Thus, unlike in sectoring, a handoff is not required at the MSC when the mobile travels between zones within the cell. The base station simply switches the channel to a different zone site. In this way, a given channel is active only in the particular zone in which the mobile is traveling, and hence the base station radiation is localized and interference is reduced. The channels are distributed in time and space by all three zones and are also reused in co-channel cells in the normal fashion. This technique is particularly useful along highways or along urban traffic corridors.

The advantage of the zone cell technique is that while the cell maintains a particular coverage radius, the co-channel interference in the cellular system is reduced since a large central base station is replaced by several lower powered transmitters (zone transmitters) on the edges of the cell. Decreased co-channel interference improves the signal quality and also leads to an increase in capacity without the degradation in trunking efficiency caused by sectoring. As mentioned earlier, an SI of 18 dB is typically required for satisfactory system performance in narrowband FM. For a system with $N = 7$, a D/R of 4.6 was shown to achieve this. With respect to

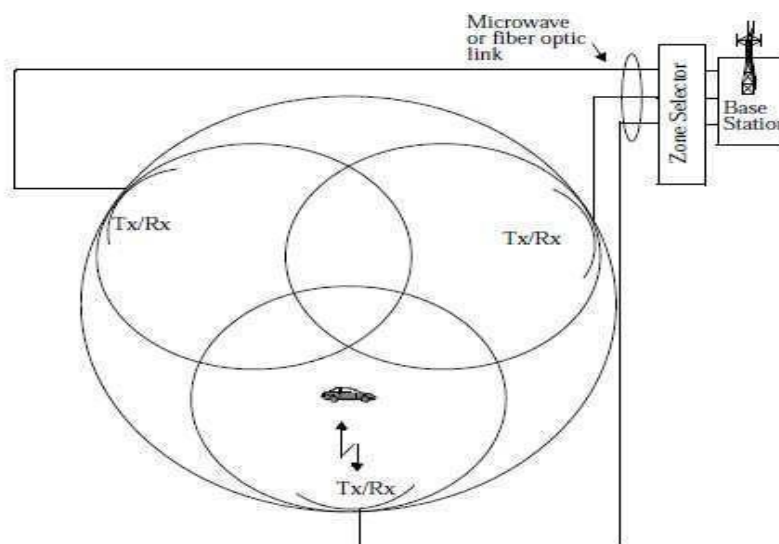

Figure 3.13 The microcell concept [adapted from [Lee91b] © IEEE].

The increased number of handoffs required when sectoring is employed results in an increased load on the switching and control link elements of the mobile system. A solution to this problem was presented by Lee [Lee91b]. This proposal is based on a microcell concept for seven cell the zone microcell system, since transmission at any instant is confined to a particular zone, this implies that a D_z/R_z of 4.6 (where D_z is the minimum distance between active co-channel zones and R_z is the zone radius) can achieve the required link performance. In Figure 3.14, let each individual hexagon represents a zone, while each group of three hexagons represents a cell. The zone radius R_z is approximately equal to one hexagon radius. Now, the capacity of the zone microcell system is directly related to the distance between co-channel cells, and not zones. This distance is represented as D in Figure 3.14. For a D_z/R_z value of 4.6, it can be seen from the geometry of Figure 3.14 that the value of co-channel reuse ratio, D/R , is equal to three, where R is the radius of the cell and is equal to twice the length of the hexagon radius. Using Equation (3.4), $D/R = 3$ corresponds to a cluster size of $N = 3$. This reduction in the cluster size from $N = 7$ to $N = 3$ amounts to a 2.33 times increase in capacity for a system completely based on the zone microcell concept. Hence for the same S/I requirement of 18 dB, this system provides a significant increase in capacity over conventional cellular planning.

By examining Figure 3.14 and using Equation (3.8) [Lee91b], the exact worst case S/I of the zone microcell system can be estimated to be 20 dB. Thus, in the worst case, the system provides a margin of 2 dB over the required signal-to-interference ratio while increasing the capacity by 2.33 times over a conventional seven-cell system using omnidirectional antennas.

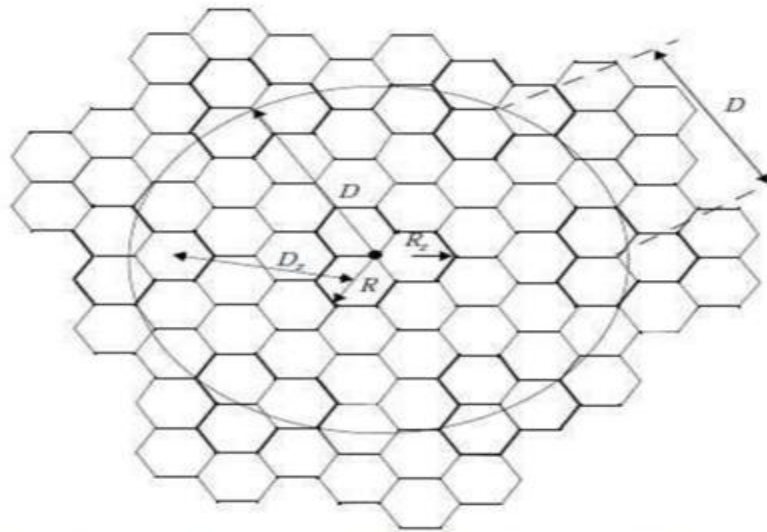

Figure 3.14 Define D , D_z , R , and R_z for a microcell architecture with $N = 7$. The smaller hexagons form zones and three hexagons (outlined in bold) together form a cell. Six nearest co-channel cells are shown.

No loss in trunking efficiency is experienced. Zone cell architectures are being adopted in many cellular and personal communication systems.

UNIT-II (A)

CO-CHANNEL INTERFERENCE

The frequency-reuse method is useful for increasing the efficiency of spectrum usage but results in cochannel interference because the same frequency channel is used repeatedly in different cochannel cells. Application of the cochannel interference reduction factor $q = D/R = 4.6$ for a seven-cell reuse pattern ($K = 7$).

In most mobile radio environments, use of a seven-cell reuse pattern is not sufficient to avoid cochannel interference. Increasing $K > 7$ would reduce the number of channels per cell, and that would also reduce spectrum efficiency. Therefore, it might be advisable to retain the same number of radios as the seven-cell system but to sector the cell radially, as if slicing a pie. This technique would reduce cochannel interference and use channel sharing and channel borrowing schemes to increase spectrum efficiency.

REAL TIME CO-CHANNEL INTERFERENCE MEASURED AT MOBILE RADIO TRANSCEIVER

When the carriers are angularly modulated by the voice signal and the RF frequency difference between them is much higher than the fading frequency, measurement of the signal carrier-to-interference ratio C/I reveal that the signal is

$$e_1 = S(t) \sin(\omega t + \phi_1) \quad (9.3-1)$$

and the interference is

$$e_2 = I(t) \sin(\omega t + \phi_2) \quad (9.3-2)$$

The received signal is

$$e(t) = e_1(t) + e_2(t) = R \sin(\omega t + \psi) \quad (9.3-3)$$

where

$$R = \sqrt{[S(t) \cos \phi_1 + I(t) \cos \phi_2]^2 + [S(t) \sin \phi_1 + I(t) \sin \phi_2]^2} \quad (9.3-4)$$

and

$$\psi = \tan^{-1} \frac{S(t) \sin \phi_1 + I(t) \sin \phi_2}{S(t) \cos \phi_1 + I(t) \cos \phi_2} \quad (9.3-5)$$

The envelope R can be simplified in Eq. (9.3-4), and R^2 becomes

$$R^2 = [S^2(t) + I^2(t) + 2S(t)I(t) \cos(\phi_1 - \phi_2)] \quad (9.3-6)$$

Following kozono and sakamoto s analysis Eq (9.3-6),the term $S^2(t)+I^2(t)$ fluctuates close to the fading frequency V/λ and the term $2S(t)I(t)\cos(\phi_1-\phi_2)$ fluctuates to a frequency close to $d/dt(\phi_1-\phi_2)$.which is much higher than the fading frequency. Then the two parts of the squared envelope can be separated as

$$X = S^2(t) + I^2(t) \quad (9.3-7)$$

$$Y = 2S(t)I(t) \cos(\phi_1 - \phi_2) \quad (9.3-8)$$

CELLULAR MOBILE COMMUNICATIONS

assume that the random variables $s(t), I(t), \phi_1, \phi_2$ are independent ;then the average processes on X and Y are

$$\overline{X} = \overline{S^2(t)} + \overline{I^2(t)} \quad (9.3-9)$$

$$\overline{Y^2} = 4\overline{S^2(t)I^2(t)}(1/2) = 2\overline{S^2(t)I^2(t)} \quad (9.3-10)$$

The signal to Interference ratio Γ becomes

$$\Gamma = \frac{\overline{S^2(t)}}{\overline{I^2(t)}} = k + \sqrt{k^2 - 1} \quad (9.3-11)$$

$$k = \frac{\overline{X^2}}{\overline{Y^2}} - 1 \quad (9.3-12)$$

Because X and Y can be separated in Eq.(9.3-6),the preceding computation of Γ in Eq.(9.3-11)could have been accomplished by means of an envelope detector ,analog to digital converter, and a micro computer. The sampling delay time Δt should be small enough to satisfy

$$S(t) \approx S(t + \Delta t), \quad I(t) \approx I(t + \Delta t) \quad (9.3-13)$$

and

$$E[\cos[\phi_1(t) - \phi_2(t)] \cos[\phi_1(t + \Delta t) - \phi_2(t + \Delta t)]] \approx 0 \quad (9.3-14)$$

Determining the delay time Δt to meet the requirement of Eq.(9.3-13) for this calculation is difficult and is a drawback to this measurement technique. Therefore, real time cochannel interference measurement is difficult to achieve in practice.

DESIGN OF ANTENNA SYSTEM

DESIGN OF AN OMNIDIRECTIONAL ANTENNA SYSTEM IN THE WORST CASE:

The value of $q = 4.6$ is valid for a normal interference case in a $K=7$ cell pattern. In this section we would like to prove that a $K=7$ cell pattern does not provide a sufficient frequency re-use distance separation even when an ideal condition of flat terrain is assumed. The worst case is at the location where the weakest signal from its own cell site but strong interferences from all interfering cell sites. In the worst case the mobile unit is at the cell boundary R, as shown in Fig. 3. The distances from all six cochannel interfering sites are also shown in the figure: two distances of $D - R$, two distances of D, and two distances of $D + R$.

Following the mobile radio propagation rule of 40 dB/dec, we obtain

$$C \propto R^{-4} \quad I \propto D^{-4}$$

Then the carrier-to-interference ratio is

$$\begin{aligned} \frac{C}{I} &= \frac{R^{-4}}{2(D - R)^{-4} + 2(D)^{-4} + 2(D + R)^{-4}} \\ &= \frac{1}{2(q - 1)^{-4} + 2(q)^{-4} + 2(q + 1)^{-4}} \end{aligned} \quad (9.4-1a)$$

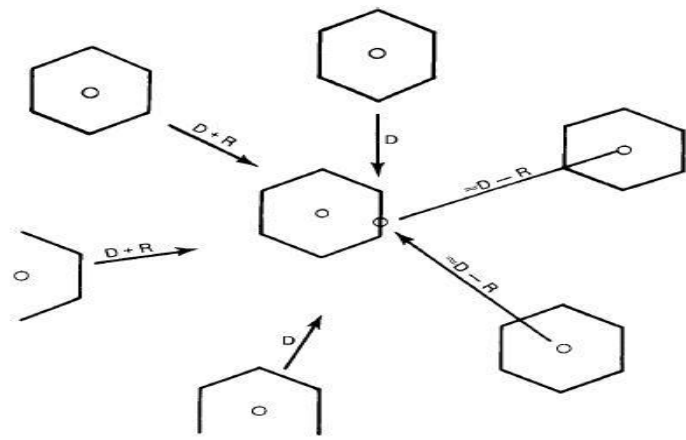

Fig.3.Cochannel interference (worst case)

Where $q=4.6$ is derived from the normal case. Substituting $q=4.6$ into above eqn. we obtain $C/I = 54$ or 17 dB, which is lower than 18 dB. To be conservative, we may use the shortest distance $D - R$ for all six interferers as a worst case; then we have

$$\frac{C}{I} = \frac{R^{-4}}{6(D - R)^{-4}} = \frac{1}{6(q - 1)^{-4}} = 28 = 14.47 \text{ dB}$$

In reality, because of the imperfect site locations and the rolling nature of the terrain configuration, the C/I received is always worse than 17 dB and could be 14 dB and lower. Such an instance can easily occur in a heavy traffic situation; therefore, the system must be designed around the C/I of the worst case. In that case, a cochannel interference reduction factor of $q=4.6$ is insufficient.

Therefore, in a unidirectional-cell system, $K = 9$ or $K = 12$ would be a correct choice. Then the values of q are

$$q = \begin{cases} \frac{D}{R} = \sqrt{3K} \\ 5.2 & K = 9 \\ 6 & K = 12 \end{cases}$$

Substituting these values in Eq. (9.4-1), we obtain

$$\begin{aligned} \frac{C}{I} &= 84.5 (=) 19.25 \text{ dB} & K &= 9 \\ \frac{C}{I} &= 179.33 (=) 22.54 \text{ dB} & K &= 12 \end{aligned}$$

DESIGN OF ANTENNA SYSTEM

Design of a Directional Antenna System:

When the call traffic begins to increase, we need to use the frequency spectrum efficiently and avoid increasing the number of cells K in a seven-cell frequency reuse pattern. When K increases, the number of frequency channels assigned in a cell must become smaller (assuming a total allocated channel divided by K) and the efficiency of

CELLULAR MOBILE COMMUNICATIONS

applying the frequency reuse scheme decrease.

Instead of increasing the number K in a set of cells, let us keep $K = 7$ and introduce a directional antenna arrangement. The cochannel interference can be reduced by using directional antenna. This means that each cell is divided into three or six sectors and uses three or six directional antennas at a base station. Each sector is assigned a set of frequencies (channels). The interference between two cochannel cells decreases as shown Fig.4.2

Directional antennas in $K=7$ cell patterns:

Three sector case: The three-sector case is shown in Fig.4.2. To illustrate the worst case situation, two cochannel cells are shown in Fig. 4.3(a). The mobile unit at position E will experience greater interference in the lower shaded cell sector than in the upper shaded cell-sector site. This is because the mobile receiver receives the weakest signal from its own cell but fairly strong interference from the interfering cell.

In a three-sector case, the interference is effective in only one direction because the front-to-back ratio of a cell-site directional antenna is at least 10 dB or more in a mobile radio environment. The worst-case cochannel interference in the directional-antenna sectors in which interference occurs may be calculated. Because of the use of directional antennas, the number of principal interferers is reduced from six to two (Fig.4.2). The worst case of C/I occurs when the mobile unit is at position E, at which point the distance between the mobile unit and the two interfering antennas is roughly $D + (R/2)$; however, C/I can be calculated more precisely as follows. The value of C/I can be obtained by the following expression (assuming that the worst case is at position E at which the distances from two interferers are $D + 0.7R$ and D).

$$\begin{aligned} \frac{C}{I}(\text{worst case}) &= \frac{R^{-4}}{(D + 0.7R)^{-4} + D^{-4}} \\ &= \frac{1}{(q + 0.7)^{-4} + q^{-4}} \end{aligned}$$

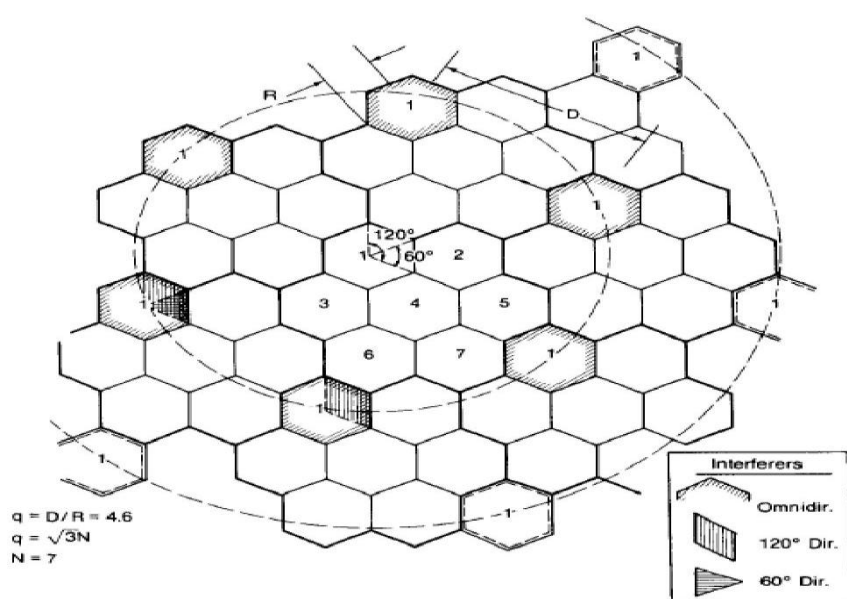

Fig.4.2. Interfering cells shown in a seven cell system (two-tiers)

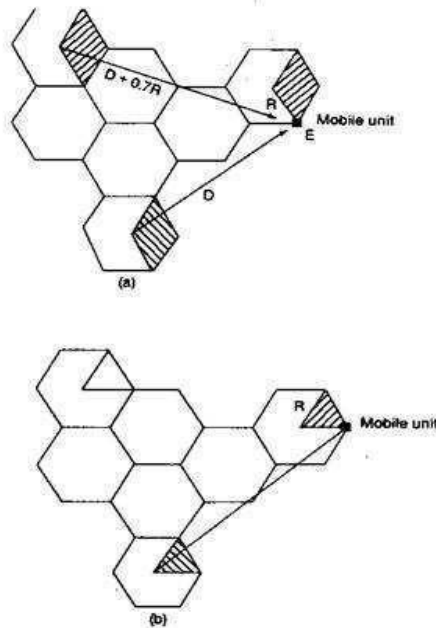

Fig.4.3. Determination of C/I in a directional antenna system. (a)Worst case in a 120 directional Antenna system (N=7); (b) worst case in a 60 directional antenna system(N=7)

Let $q=4.6$; then we have

$$\frac{C}{I} (\text{worst case}) = 285 (-) 24.5 \text{ dB}$$

The C/I received by a mobile unit from the 120° directional antenna sector system expressed in Eq. above greatly exceeds 18 dB in a worst case. Equation above shows that using directional antenna sectors can improve the signal-to-interference ratio, that is, reduce the cochannel interference. However, in reality, the C/I could be 6 dB weaker than in Eq. given above in a heavy traffic area as a result of irregular terrain contour and imperfect site locations. The remaining 18.5 dB is still adequate.

Six-sector case: We may also divide a cell into six sectors by using six 60°-beam directional antennas as shown in Fig.4.2. In this case, only one instance of interference can occur in each sector as shown in Fig, 4.2. Therefore, the carrier-to-interference ratio in this case is which shows a further reduction of cochannel interference. If we use the same argument as we did for Eq. above and subtract 6 dB from the result of Eq. the remaining 23 dB is still more than adequate. When heavy traffic occurs, the 60°-sector configuration can be used to reduce cochannel interference. However, fewer channels are generally allowed in a 60° sector and the trunking efficiency decreases. In certain cases, more available channels could be assigned in a 60° sector.

Directional antenna in K = 4 cell pattern:

Three-sector case: To obtain the carrier-to-interference ratio, we use the same procedure as in the K = 7 cell-pattern system. The 120° directional antennas used in the sectors reduced the interferers to two as in K = 7 systems,

CELLULAR MOBILE COMMUNICATIONS

as shown in Fig.4.4.

We can apply Eq. here. For $K = 4$, the value of $q = 3.46$; therefore, Eq. becomes

$$\frac{C}{I} \text{ (worst case)} = \frac{1}{(q + 0.7)^{-4} + q^{-4}} = 97 = 20 \text{ dB}$$

If, using the same reasoning used with Eq. above, 6 dB is subtracted from the result of Eq. above, the remaining 14 dB is unacceptable.

Six-sector case: There is only one interferer at a distance of $D + R$ shown in Fig.4.4. With $q=3.46$, we can obtain

$$\frac{C}{I} \text{ (worst case)} = \frac{R^{-4}}{(D + R)^{-4}} = \frac{1}{(q + 1)^{-4}} = 355 = 26 \text{ dB}$$

If 6 dB is subtracted from the above result, the remaining 20 dB is adequate.

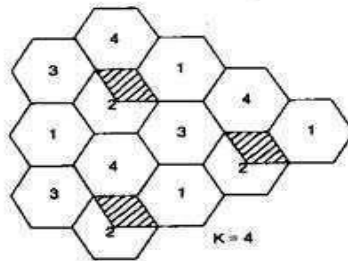

Fig. 4.4 Interference with frequency reuse pattern K=4.

Under heavy traffic conditions, there is still a great deal of concern over using a $K = 4$ cell pattern in a 60° sector.

Comparing K =7 and N =4 systems:

A $K = 7$ cell pattern system is a logical way to begin an omniscell system. The co-channel reuse distance is more or less adequate, according to the designed criterion. When the traffic increases, a three sector system should be implemented, that is, with three 120° directional antennas in place. In certain hot spots, 60° sectors can be used locally to increase the channel utilization.

If a given area is covered by both $K=7$ and $K=4$ cell patterns and both patterns have a six-sector configuration, then the $K=7$ system has a total of 42 sectors, but the $K=4$ system has a total of only 24 sectors and, of course, the system of $K=7$ and six sectors has less cochannel interference.

One advantage of 60° sectors with $K=4$ is that they require fewer cell sites than 120 sectors with $K=7$. Two disadvantages of 60° sectors are that (1) they require more antennas to be mounted on the antenna mast and (2) they often require more frequent handoffs because of the increased chance that the mobile units will travel across the six sectors of the call. Furthermore, assigning the proper frequency channel to the mobile unit in each sector is more difficult unless the antenna height at the cell site is increased so that the mobile unit can be located more precisely. In reality the terrain is not flat, end coverage is never uniformly distributed; in addition, the

CELLULAR MOBILE COMMUNICATIONS

directional antenna front-to-back power ratio in the field is very difficult to predict. In small cells, interference could become uncontrollable; then the use of a K = 4 pattern with 60 deg sectors in small cells needs to be considered only for special implementations such as portable cellular systems or narrow beam applications. For small cells, a better alternative scheme is to use a K = 7 pattern with 120° sectors plus the underlay-overlay configuration.

ANTENNA PARAMETERS AND THEIR EFFECTS:

LOWERING THE ANTENNA HEIGHT: Lowering the antenna height does not always reduce the co-channel interference. In some circumstances, such as on fairly flat ground or in a valley situation, lowering the antenna height will be very effective for reducing the cochannel and adjacent-channel interference. However, there are three cases where lowering the antenna height may or may not effectively help reduce the interference.

ON A HIGH HILL OR A HIGH SPOT: The effective antenna height, rather than the actual height, is always considered in the system design. Therefore, the effective antenna height varies according to the location of the mobile unit. When the antenna site is on a bill, as shown in Fig. 5.1(a), the effective antenna height is $h_1 + H$.

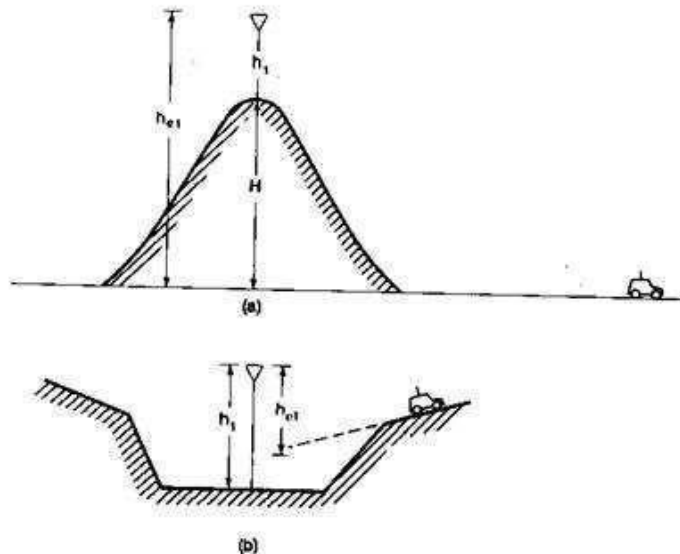

Fig. 5.1. Lowering the antenna height (a) on a high hill and (b) in a valley

If we reduce the actual antenna height to $0.5h_1$, the effective antenna height becomes $0.5h_1 + H$. The reduction in gain resulting from the height reduction is

$$\begin{aligned} G = \text{gain reduction} &= 20 \log_{10} \frac{0.5h_1 + H}{h_1 + H} \\ &= 20 \log_{10} \left(1 - \frac{0.5h_1}{h_1 + H} \right) \end{aligned}$$

CELLULAR MOBILE COMMUNICATIONS

If $h_1 \ll H$, then the above equation becomes

$$G = 20 \log_{10} 1 = 0 \text{ dB}$$

This simply proves that lowering antenna height on the hill does not reduce the received power at either the cell site or the mobile unit.

In a valley: The effective antenna height as seen from the mobile unit shown in Fig. 5.1(b) is h_{e1} , which is less than the actual antenna height h_1 . If $h_{e1} = 2/3 h_1$, and the antenna is lowered to $1/2 h_1$, then the new effective antenna height is

$$h_{e1} = 1/2 h_1 - (h_1 - 2/3 h_1) = 1/6 h_1$$

Then the antenna gain is reduced by

$$G = 20 \log \frac{1/6 h_1}{2/3 h_1} = -12 \text{ dB}$$

This simply proves that the lowered antenna height in a valley is very effective in reducing the radiated power in a distant high elevation area. However, in the area adjacent to the cell-site antenna the effective antenna height is the same as the actual antenna height. The power reduction caused by decreasing antenna height by half is only

$$20 \log \frac{1/2 h_1}{h_1} = -6 \text{ dB}$$

In a forested area: In a forested area, the antenna should clear the tops of any trees in the vicinity, especially when they are very close to the antenna. In this case decreasing the height of the antenna would not be the proper procedure for reducing cochannel interference because excessive attenuation of the desired signal would occur in the vicinity of the antenna and in its cell boundary if the antenna were below the treetop level.

DIVERSITY TECHNIQUES:

SPACE DIVERSITY CONSIDERATIONS

Space diversity, also known as antenna diversity, is one of the most popular forms of diversity used in wireless systems. Conventional cellular radio systems consist of an elevated base station antenna and a mobile antenna close to the ground. The existence of a direct path between the transmitter and the receiver is not guaranteed and the possibility of a number of scatterers in the vicinity of the mobile suggests a Rayleigh fading signal. From this model Jakes deduced that the signals received from spatially separated antennas on the mobile would have essentially uncorrelated envelopes for antenna separations of one half wavelength or more.

The concept of antenna space diversity is also used in base station design. At each cell site, multiple base station receiving antennas are used to provide diversity reception. However, since the important scatterers are generally on the ground in the vicinity of the mobile, the base station antennas must be spaced considerably far

CELLULAR MOBILE COMMUNICATIONS

apart to achieve decorrelation. separations on the order of several tens of wavelengths are required at the base station .space diversity can thus be used at either the mobile or base station or both .figure shows general block diagram of a space diversity scheme

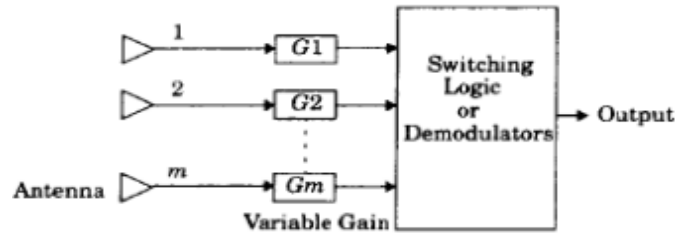

Figure 6.12 generalized block diagram for space diversity.

POLARIZATION DIVERSITY:

At the base station, space diversity is considerably less practical than at the mobile because the narrow angle of incident fields requires large antenna spacings. the comparatively high cost of using space diversity at the base station prompts the consideration of using orthogonal polarization to exploit polarization diversity .while this only provides two diversity branches it does allow the antenna elements to be collocated.

In the early days of cellular radio, all subscriber units were mounted in vehicles and used vertical whip antennas. Today, however, over half of the subscriber units are portable. This means that most subscribers are no longer using vertical polarization due to hand tilting when the portable cellular phone is used. This recent phenomenon has sparked interest in polarization diversity at the base station. Measured horizontal and vertical polarization paths between a mobile and a base station are reported to be uncorrelated by lee and Yeh. The decorrelation for the signals in each polarization is caused by multiple reflections in the channel between the mobile and base station antennas. That the reflection coefficient for each polarization is different, which results in different amplitudes and phases for phases for each, or at least some, of the reflections. After sufficient random reflections, the polarizations state of the signal will be independent of the transmitted polarization. In practice; however, there is some dependence of the received polarization on the transmitted polarization.

Circular and linear polarized antennas have been used to characterize multipath inside buildings. When the path was obstructed, polarization diversity was found to dramatically reduce the multipath delay spread without significantly decreasing the received power.

FREQUENCY DIVERSITY:

Frequency diversity transmits information on more than one carrier frequency. The rationale behind this technique is that frequencies separated by more than the coherence bandwidth of the channel will not experience the same fades. Theoretically, if the channels are uncorrelated, the probability of simultaneous fading will be the product of the individual fading probabilities.

CELLULAR MOBILE COMMUNICATIONS

Frequency diversity is often employed in microwave line of sight links which carry several channels in a frequency division multiplex mode (FDM).due to troposphere propagation and resulting refraction. Deep fading sometimes occurs. In practice 1: N protection switching is provided by a radio licensee. Where in one frequency is nominally idle but is available on a standby basis to provide frequency diversity switching for any one of the N other carriers (frequencies) being used on the same link, each carrying independent traffic. When diversity is needed, the appropriate traffic is simply switched to the backup frequency. This technique has the disadvantages that it not only requires spare bandwidth but also requires that there be as many receivers as there are channels used the frequency diversity. However, for critical traffic, the expense may be justified.

TIME DIVERSITY: Time diversity repeatedly transmits information at time spacing's that exceed the coherence time of the channel, so that multiple repetitions of the signal will be received with independent fading conditions, thereby providing for diversity. One modern implementation of time diversity involves the use of the RAKE receiver for spread spectrum CDMA,where the multipath channel provides redundancy in the transmitted messages.

CELLULAR MOBILE COMMUNICATIONS

UNIT-2(B) NON CO-CHANNEL INTERFERENCE

ADJUSCENT CHANNEL INTERFERENCE

Adjacent channel interference can be eliminated on the basis of the channel assignment, the filter characteristics and be reduction of near-end-far-end interference. Adjacent channel interference is a board term. It includes next channel interference (the channel next to the operating channel) and neighboring channel interference (more than one channel away from the operating channel). Adjacent channel interference can be reduced by the frequency assignment.

NEXT CHANNEL INTERFERENCE

Next channel interference in an AMPS system affecting a particular mobile unit cannot be caused by transmitters in the common cell site but must originate at several other cell sites. This is because any channel combiner at the cell site must combine the selected channels. Normally 21 channels(630 kHz) away, or at least 8 or 10 channels away from the desired one.therefore,next channel interference will arrive at the mobile unit from other cell sites if the system is not designed property .also a mobile unit initiating a call on a control channel in cell may cause interference with the next control channel at another cell site. The methods for reducing this next channel interference use the receiving end. The channel filter characteristics are a 6dB/oct slope in the voice band and a 24 dB/oct falloff outside the voice band region. If Next channel signal is stringer than 23 Db, it Will interfere with the desired signal. The filter with a sharp falloff slope can help to reduce all the adjacent channel interference, including the next channel interference. The same consideration is applied to digital systems.

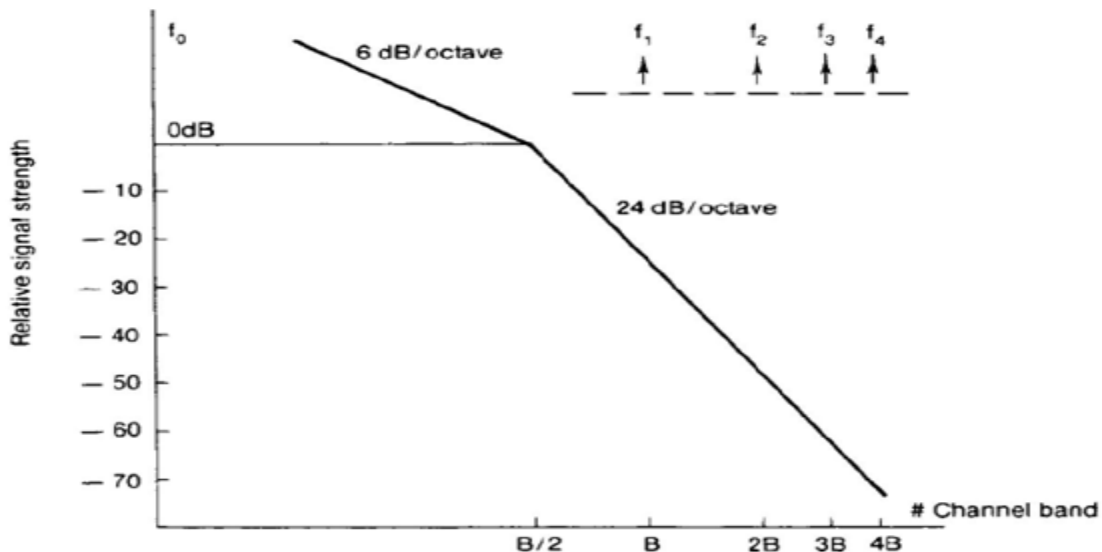

FIGURE 10.3 Characteristics of channel-band filter.

CELLULAR MOBILE COMMUNICATIONS

NEIGHBORING CHANNEL INTERFERENCE

The channels that are several channels away from next channel will cause interference with the desired signal. Usually, a fixed set of serving channels is assigned to each cell site. If all the channels are simultaneously transmitted at one cell site antenna; a sufficient amount of band isolation between channels is required for a multichannel combiner to reduce products. This requirement is no different from other non mobile radio systems. Assume that band separation requirements can be resolved, for example, by using multiple antennas instead of one antenna at the cell site. There will be no intermodulation products. A truly linear broadband amplifier can realize this idea. However, it is a new evolving technology.

Another type of adjacent channel interference is unique to the mobile radio system. In the mobile radio system, most mobile units are in motion simultaneously. Their relative positions change from time to time. In principle, the optimum channel assignments that avoid adjacent channel interference must also change from time to time .one unique station that causes adjacent channel interference in mobile radio system.

TRANSMITTING AND RECEIVING CHANNELS INTERFERENCE

In FDMA and TDMA systems, the transmitting channels and receiving channels have to be separated by a guard band mostly 29MHz.it is because the transmitting channels are so strong that they can mask the weak signals received from receiving channels. The duplexer can only provide 30 dB to 40dB isolation. The band isolation is the other means to reduce the interference.

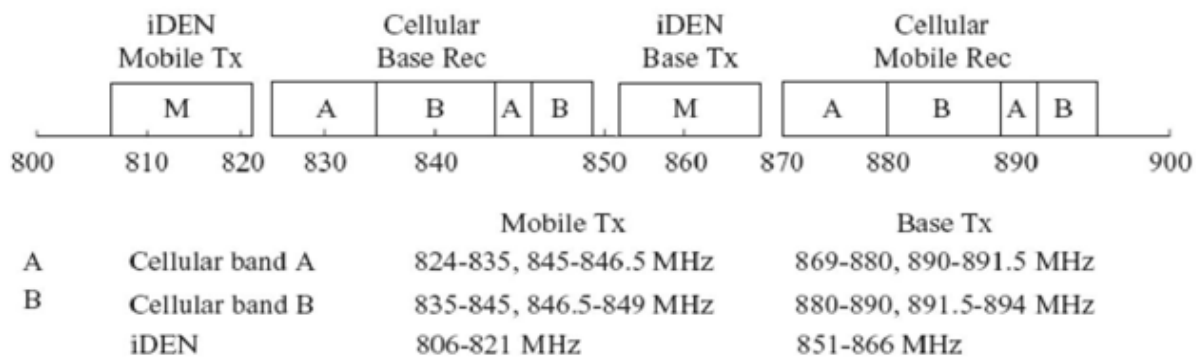

FIGURE 10.4 Cellular and iDEN spectrum in 800 MHz.

INTERFERENCE FROM ADJACENT SYSTEMS

The frequency bands allocated between AMPS and iDEN in 800 MHz systems are shown in Fig 10.4 in 1993. IDEN transmitted in the band 851-866 MHz , using several broad band amplifiers to cover this band. The IM(2A-B)generated from the nonlinear amplifier interfered with the cellular base received signals. Then , the broadband amplifiers were removed.

NEAR-END-FAR-END INTERFERENCE

In One Cell

Because motor vehicles in a given cell are usually moving, some mobile units are close to the cell site and some are not. The close-in mobile unit has a strong signal that causes adjacent-channel interference (see Fig. 10.5a). In this situation, near-end-far-end interference can occur only at the reception point in the cell site.

If a separation of $5B$ (five channel bandwidths) is needed for two adjacent channels in a cell in order to avoid the near-end-far-end interference, it is then implied that a minimum separation of $5B$ is required between each adjacent channel used with one cell.

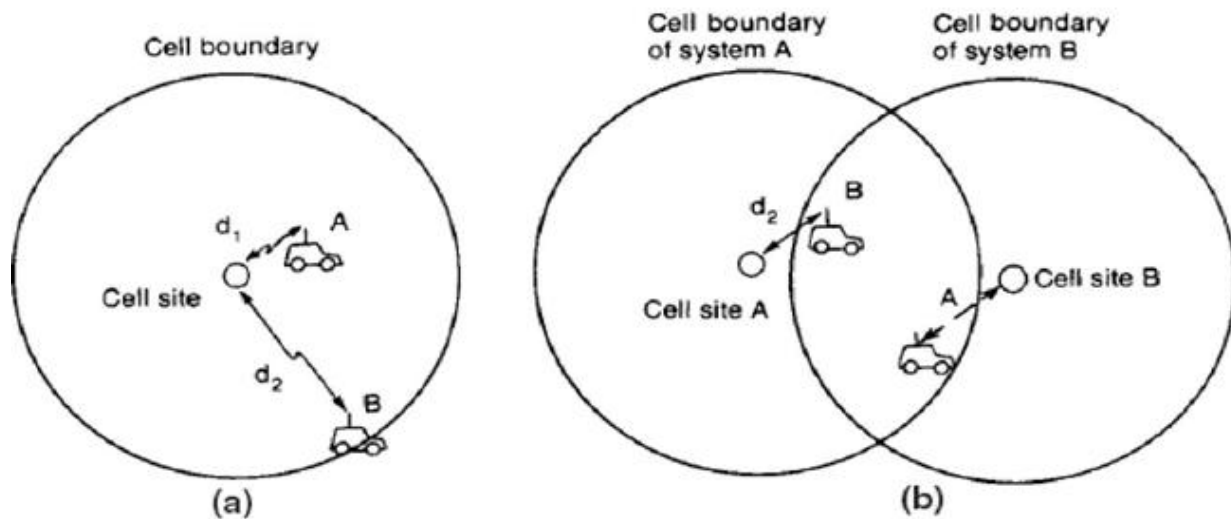

FIGURE 10.5 Near-end-far-end (ratio) interference. (a) In one cell; (b) in two-system cells.

Because the total frequency channels are distributed in a set of N cells, each cell only has $1/N$ of the total frequency channels. We denote $\{F_1\}$, $\{F_2\}$, $\{F_3\}$, $\{F_4\}$ for the sets of frequency channels assigned in their corresponding cells C_1 , C_2 , C_3 , C_4 .

The issue here is how can we construct a good frequency management chart to assign the N sets of frequency channels properly and thus avoid the problems indicated above. The following section addresses how cellular system engineers solve this problem in two different systems.

In Cells of Two Systems

Adjacent-channel interference can occur between two systems in a duopoly-market system. In this situation, adjacent-channel interference can occur at both the cell site and the mobile unit.

For instance, mobile unit A can be located at the boundary of its own home cell A in system A but very close to cell B of system B as shown in Fig 10.5b. The other situation would occur if mobile unit B were at the boundary of cell B of system B but very close to cell A of system A. Following the definition of near-end-far-end interference

CELLULAR MOBILE COMMUNICATIONS

the solid arrow indicates that interference may occur at cell site A and the dotted arrow indicates that interference may occur at mobile unit A. Of course, the same interference will be introduced at cell site B and mobile unit B.

Thus, the frequency channels of both cells of the two systems must be coordinated in the neighborhood of the two-system frequency bands. This phenomenon causes a great concern as indicated in the additional frequency-spectrum allocation charts in Fig. 10.6 as an example.

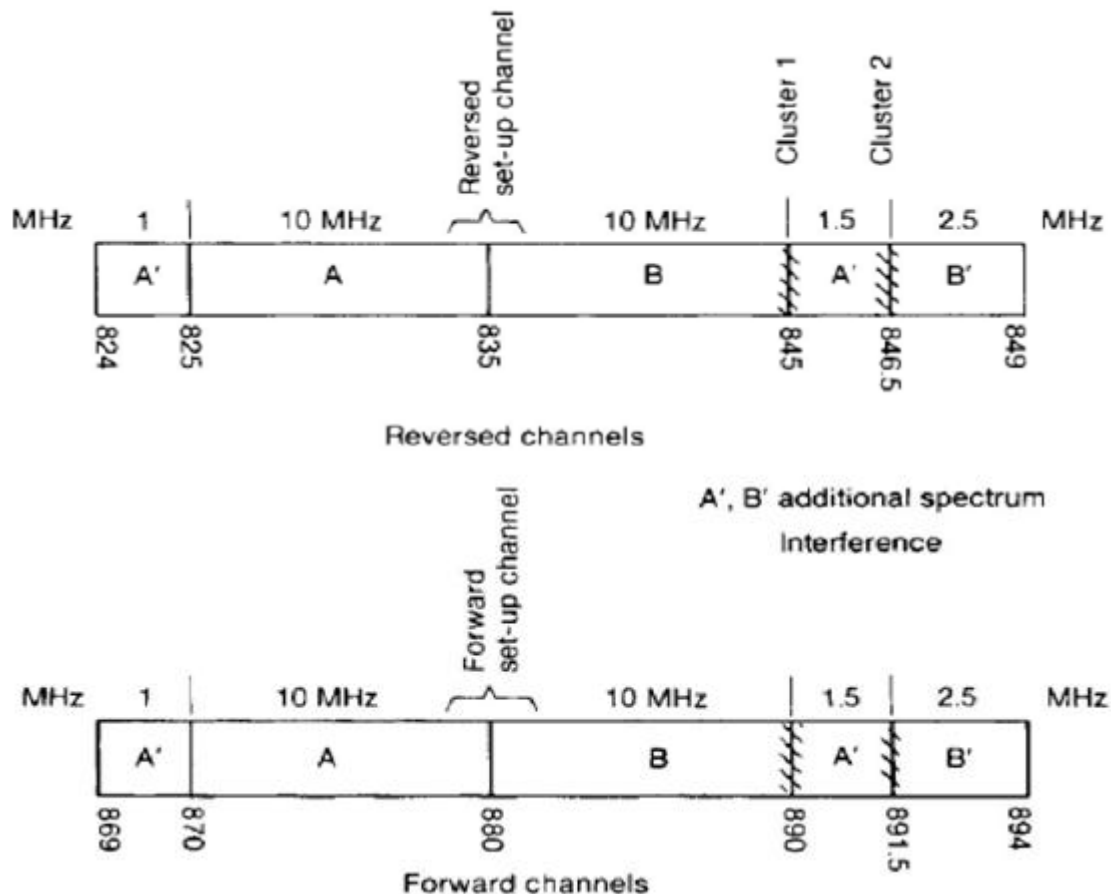

FIGURE 10.6 Spectrum allocation with new additional spectrum.

The two causes of near-end–far-end interference of concern here are

1. *Interference caused on the set-up channels.* Two systems try to avoid using the neighborhood of the set-up channels as shown in Fig. 10.6.
2. *Interference caused on the voice channels.* There are two clusters of frequency sets as shown in Fig. 10.6 that may cause adjacent-channel interference and should be avoided. The cluster can consist of 4 to 5 channels on each side of each system, that is, 8 to 10 channels in each cluster. The channel separation can be based on two assumptions.

CELLULAR MOBILE COMMUNICATIONS

- Received interference at the mobile unit.* The mobile unit is located away from its own cell site but only 0.25 mi away from the cell site of another system.
- Received interference at the cell site.* The cell site is located 10 mi away from its own mobile unit but only 0.25 mi from the mobile unit of another system.

CROSS TALK

When the cellular radio system was designed, the system was intended to function like a telephone wire line. A wire pair serves both directions of traffic at the line transmission. In a mobile cellular system there is a pair of frequencies, occupying a bandwidth of 60 kHz, which we simply call a "channel." A frequency of 30 kHz serves a received path, and the other 30 kHz accommodates a transmitted path.

Because of paired-frequency (as a wire pair) coupling through the two-wire–four-wire hybrid circuitry at the telephone central office, it is possible to hear voices in both frequencies (in the frequency pair) simultaneously while scanning on only one frequency in the air. Therefore, just as with a wire telephone line, the full conversation can be heard on a single frequency (either one of the two). This phenomenon does not annoy cellular mobile users; when they talk they also listen to themselves through the phone receiver. They are not even aware that they are listening to their own voices.

This unnoticeable cross-talk phenomenon in frequency pairs has no major impact on both wire telephone line and cellular mobile performance. But when real cross talk occurs it has a larger impact on the cellular mobile system than on the telephone line, because the amount of cross talk could potentially be doubled since cross talk occurring on one frequency will be heard on the other (paired) frequency. Cross talk occurring on the reverse voice channel (RVC) can be heard on the forward voice channel (FVC), and cross talk occurring on the forward voice channel can be heard on the reverse channel. Therefore, the cross-talk effect is twofold. A number of situations are conducive to cross talk.

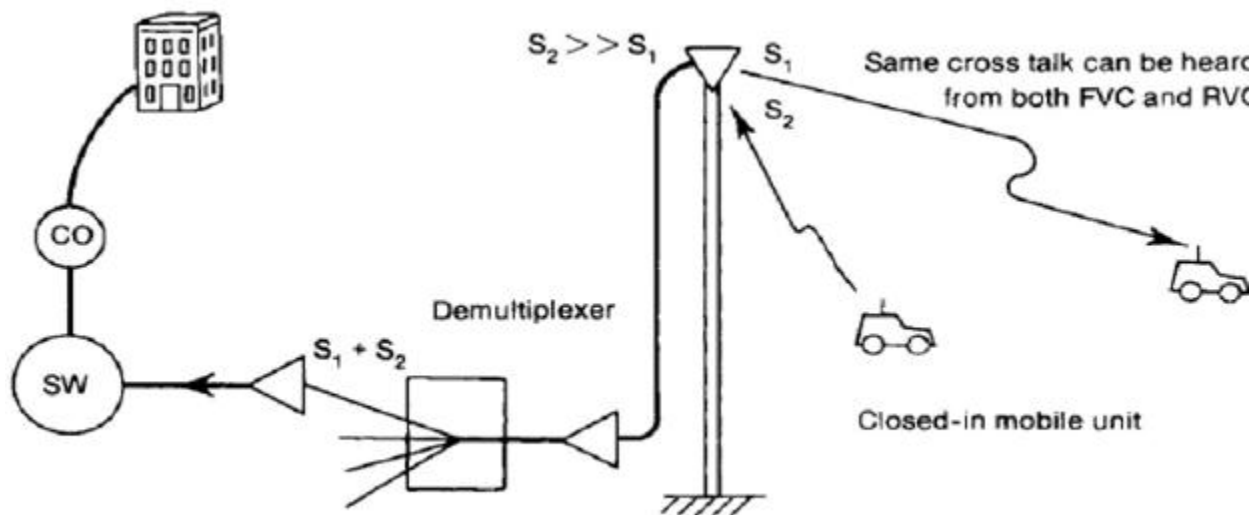

FIGURE 10.10 Cross-talk phenomenon.

Near-end mobile unit. Cross talk can occur when one mobile unit (unit A) is very close to the cell site and the other (unit B) is far from the cell site. Both units are calling to their land-line parties as shown in Fig. 10.10. The near-end mobile unit has a strong signal such that the demultiplexer cannot have an isolation (separation) of more than 30 dB. Then the strong signal can generate strong cross talk while the received signal from mobile unit B is 30 dB weaker than signal A.

Near-end mobile units can belong to one system or to another (foreign) system. If the foreign system units are operating in the new allocated spectrum channels, cross talk can occur. When the mobile unit is close to the cell site and the cell site is capable of reducing the power of the mobile unit, the near-end mobile interference can be reduced.

If the operating frequencies of both home system units and foreign system units are in the new allocated spectrum channels and the isolation of the multicoupler (demultiplexer) could be only 30 dB, cross talk would occur in the two interfering clusters of channels (Fig. 10.10) and could not be controlled by the system operator.

Close-in mobile units. When a mobile unit is very close to the cell site and if the reception at the cell site is greater than -55 dBm, the channel preamplifier at the cell site can become saturated and produce IM as a result of the nonlinear portion of the amplification. These IM products are the spurious (unwanted frequency) signal that leaks into the desired signal and produces cross talk. Also, as mentioned previously, the same cross talk can be heard from both the forward and reverse voice channels.

Cochannel cross talk. The cochannel interference reduction ratio q should be as large as possible to compensate for the cost of site construction and the limitation of available channels at each cellular site. There are other ways to increase q , as mentioned in Chap. 9. An adequate system design will help to reduce the cochannel cross talk.

The channel combiner. The signal isolation among the forward voice channels in a channel combiner is 17 dB.⁴ The loss resulting from inserting the signal into the combiner is about 3 dB. The requirement of IM product suppression is about 55 dB. If one outlet is not matched well, the signal isolation is less than 17 dB. Therefore, for each channel an isolator is installed to provide an additional 30-dB of isolation with a 0.5-dB insertion loss. This isolator prevents any signal from leaking back to the power amplifier (see Sec. 10.7.1). Spurious signals can be cross-coupled to this weak channel while transmitting. This kind of cross-coupled interference can be eliminated by routinely checking impedance matching at the combiner.

Telephone-line cross talk. Sometimes cross talk can result from cable imbalance or switching error at the central office and be conveyed to the customer through the telephone line. Minimizing this type of cross talk should be given the same priority as reducing the number of call drops.

CELLULAR MOBILE COMMUNICATIONS

Effects on coverage and interference by power decrease and Antenna height decrease

Power Decrease

As long as the setup of the antenna configuration at the cell site remains the same, and if the cell-site transmitted power is decreased by 3 dB, then the reception at the mobile unit is also decreased by 3 dB. This is a one-on-one (i.e., linear) correspondence and thus is easy to control.

Antenna Height Decrease

When antenna height is decreased, the reception power is also decreased. However, the formula

$$\text{Antenna height gain (or loss)} = 20 \log \frac{h'_{e1}}{h_{e1}}$$

is based on the difference between the old and new effective antenna heights and not on the actual antenna heights. Therefore, the effective antenna height is the same as the actual antenna height only when the mobile unit is traveling on flat ground. It is easy to decrease antenna height to control coverage in a flat-terrain area. For decreasing antenna height in a hilly area, the signal-strength contour shown in Fig. 10.12a is different from the situation of power decrease shown in Fig. 10.12b. Therefore, a decrease in antenna height would affect the coverage; thus, antenna height becomes very difficult to control in an overall plan. Some area within the cell may have a high attenuation while another may not.

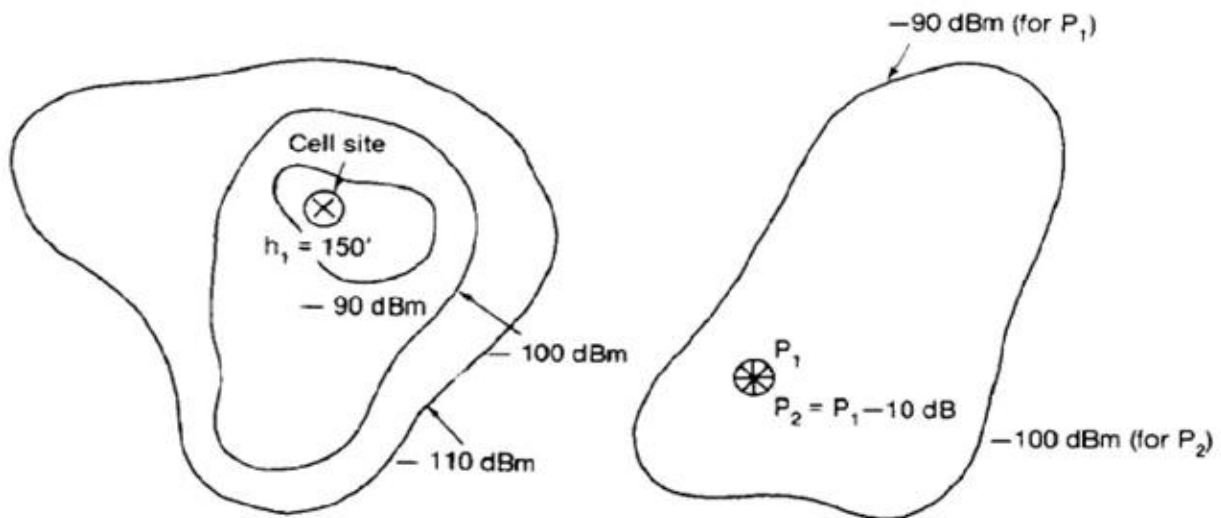

FIGURE 10.12 The signal-strength effect as measured by different parameters. (a) Different signal-strength contours. (b) Signal-strength changes with power changes.

UNIT-III

CELL COVERAGE FOR SIGNAL AND TRAFFIC

SIGNAL REFLECTIONS IN FLAT AND HILLY TERRAIN

The ground incident angle and the ground elevation angle over a communication link are described as follows. The ground incident angle θ is the angle of wave arrival incidentally pointing to the ground as shown in Fig. 1.1. The ground elevation angle is the angle of wave arrival at the mobile unit as shown in Fig. 1.1

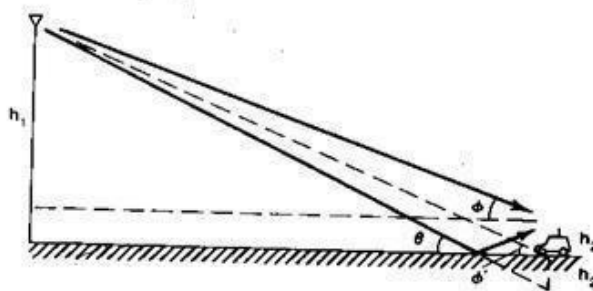

Figure 1.1 Representation of Ground Incident Angle θ and Ground Elevation Angle ϕ

Based on Snell's law, the reflection angle and incident angle are the same. Since in graphical display we usually exaggerate the hilly slope and the incident angle by enlarging the vertical scale, as shown in Fig. 1.2, then as long as the actual hilly slope is less than 100, the reflection point on a hilly slope can be obtained by following the same method as if the reflection point were on flat ground. Be sure that the two antennas (base and mobile) have been placed vertically, not perpendicular to the sloped ground. The reason is that the actual slope of the hill is usually very small and the vertical stands for two antennas are correct. The scale drawing in Fig. 1.2 is somewhat misleading however, it provides a clear view of the situation.

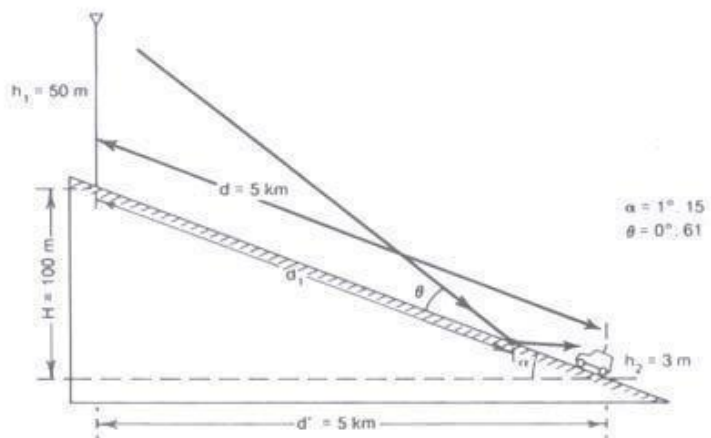

Fig 1.2 Ground reflection angle and reflection point

CELLULAR MOBILE COMMUNICATIONS

PHASE DIFFERENCE BETWEEN THE DIRECT PATH AND THE REFLECTED PATH

Based on a direct path and a ground reflected path, the equation

$$P_r = P_o \left(\frac{1}{4\pi d/\lambda} \right)^2 \left| 1 + a_v e^{j\Delta\phi} \right|^2$$

where a_v = the reflection coefficient
 $\Delta\phi$ = the phase difference between a direct path and a reflected path
 P_o = the transmitted power
 d = the distance
 λ = the wavelength

Indicates a two-wave model which is used to understand the path-loss phenomenon in a mobile radio environment. It is not the model for analyzing the multipath fading phenomenon. In a mobile environment $a_v = -1$ because of the small incident angle of the ground wave caused by a relatively low cell-site antenna height. Thus,

$$\begin{aligned} P_r &= P_o \left(\frac{1}{4\pi d/\lambda} \right)^2 \left| 1 - \cos \Delta\phi - j \sin \Delta\phi \right|^2 \\ &= P_o \frac{2}{(4\pi d/\lambda)^2} (1 - \cos \Delta\phi) = P_o \frac{4}{(4\pi d/\lambda)^2} \sin^2 \frac{\Delta\phi}{2} \end{aligned}$$

where $\Delta\phi = \beta \Delta d$
 and Δd is the difference, $\Delta d = d_1 - d_o$, from Fig. 4.4.
 $d_1 = \sqrt{(h_1 + h_2)^2 + d^2}$
 and $d_2 = \sqrt{(h_1 - h_2)^2 + d^2}$
 Since Δd is much smaller than either d_1 or d_2 ,

$$\Delta\phi = \beta \Delta d \approx \frac{2\pi}{\lambda} \frac{2h_1 h_2}{d}$$

Then the received power of Eq. (4.2-3) becomes

$$P_r = P_o \frac{\lambda^2}{(4\pi)^2 d^2} \sin^2 \frac{4\pi h_1 h_2}{\lambda d}$$

If $\Delta\phi$ is less than 0.6 rad, then $\sin(\Delta\phi/2) \approx \Delta\phi/2$, $\cos(\Delta\phi/2) \approx 1$, then

$$P_r = P_o \frac{4}{16\pi^2 (d/\lambda)^2} \left(\frac{2\pi h_1 h_2}{\lambda d} \right)^2 = P_o \left(\frac{h_1 h_2}{d^2} \right)^2, \text{ thus}$$

$$\Delta P = 40 \log \frac{d_1}{d_2} \quad (\text{a } 40 \text{ dB/dec path loss})$$

$$\Delta G = 20 \log \frac{h'_1}{h_1} \quad (\text{an antenna height gain of } 6 \text{ dB/oct})$$

CELLULAR MOBILE COMMUNICATIONS

Where P is the power difference in decibels between two different path lengths and G is the gain (or loss) in decibels obtained from two different antenna heights at the cell site. From these measurements, the gain from a mobile antenna height is only 3 dB/oct, which is different from the 6 dB/oct. Then

$$\Delta G = 10 \log \frac{h_1^2}{h_2^2}$$

CONSTANT STANDARD DEVIATION ALONG A PATH-LOSS SLOPE

When plotting signal strengths at any given radio-path distance, the deviation from predicted value is approximately 8 dB. This standard deviation of 8 dB is roughly true in many different areas. The explanation is as follows. When a line-of-sight path exists, both the direct wave path and reflected wave path are created and are strong. When an out-of-sight path exists, both the direct wave path and the reflected wave path are weak. In either case, according to the theoretical model, the 40-dB/dec path-loss slope applies. The difference between these two conditions is the 1-mi intercept (or 1-km intercept) point. It can be seen that in the open area, the 1-mi intercept is high. In the urban area, the 1-mi intercept is low. The standard deviation obtained from the measured data remains the same along the different path-loss curves regardless of environment.

Support for the above argument can also be found from the observation that the standard deviation obtained from the measured data along the predicted path-loss curve is approximately 8 dB. The explanation is that at a distance from the cell site, some mobile unit radio paths are line-of-sight, some are partial line-of-sight, and some are out-of-sight. Thus the received signals are strong, normal, and weak, respectively. At any distance, the above situations prevail. If the standard deviation is 8 dB at one radio-path distance, the same 8dB will be found at any distance. Therefore a standard deviation of 8 dB is always found along the radio path as shown in Fig.3

The standard deviation of 8 dB from the measured data near the cell site is due mainly to the close-in buildings around the cell site. The same standard deviation from the measured data at distant locations is due to the great variation along different paths around the cell site. The same standard deviation from the measured data at a distant location is due to the great variation along different radio paths.

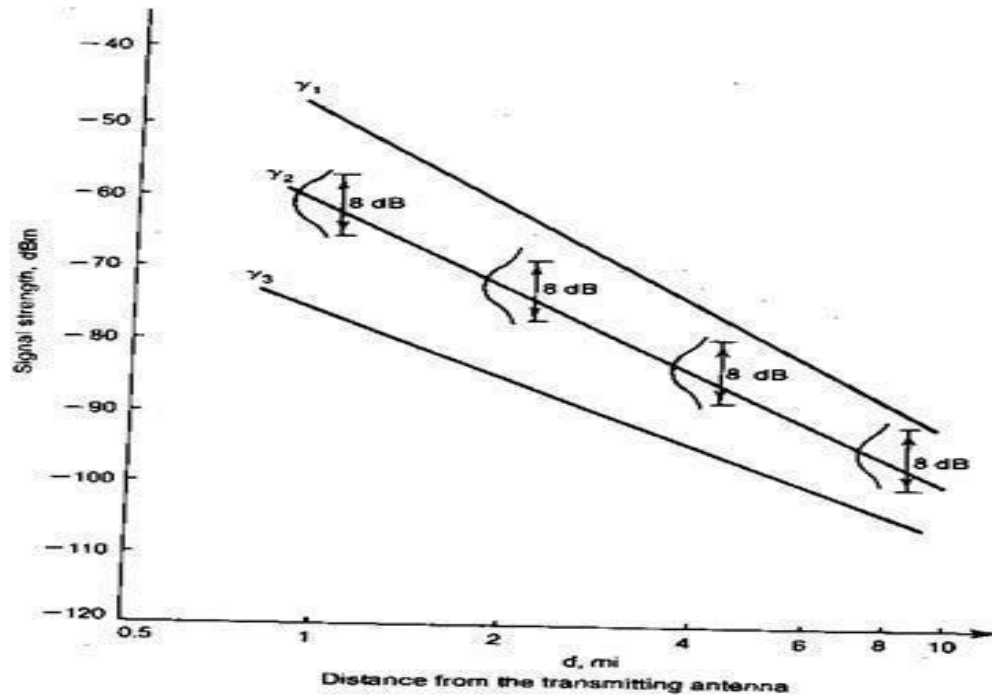

Fig 3 An 8-dB local mean spread

MERITS OF POINT-TO-POINT MODEL

The area-to-area model usually only provides an accuracy of prediction with a standard deviation of 8 dB, which means that 68 percent of the actual path-loss data are within the ± 8 dB of the predicted value. The uncertainty range is too large. The point-to-point model reduces the uncertainty range by including the detailed terrain contour information in the path-loss predictions.

The differences between the predicted values and the measured ones for the point-to-point model were determined in many areas. In the following discussion, we compare the differences shown in the Whippany, N.J., area and the Camden- Philadelphia area. First, we plot the points with predicted values at the x-axis and the measured values at the y-axis, shown in Fig. 4. The 45° line is the line of prediction without error. The dots are data from the Whippany area, and the crosses are data from the Camden-Philadelphia area. Most of them, except the one at 9 dB, are close to the line of prediction without error.

The mean value of all the data is right on the line of prediction without error. The standard deviation of the predicted value of 0.8 dB from the measured one.

In other areas, the differences were slightly larger. However, the standard deviation of the predicted value never exceeds the measured one by more than 3 dB. The standard deviation range is much reduced as compared with the maximum of 8 dB from area-to-area models. The point-to-point model is very useful for designing a mobile cellular system with a radius for each cell of 10 mi or less. Because the data follow the log-normal distribution, 68 percent of predicted values obtained from a point-to-point prediction model are within 2 to 3 dB. This point-to-point prediction can be used to provide overall coverage of all cell sites and to avoid co-

CELLULAR MOBILE COMMUNICATIONS

channel interference. Moreover, the occurrence of handoff in the cellular system can be predicted more accurately.

The point-to-point prediction model is a basic tool that is used to generate a signal coverage map, an interference area map, a handoff occurrence map, or an optimum system design configuration, to name a few applications.

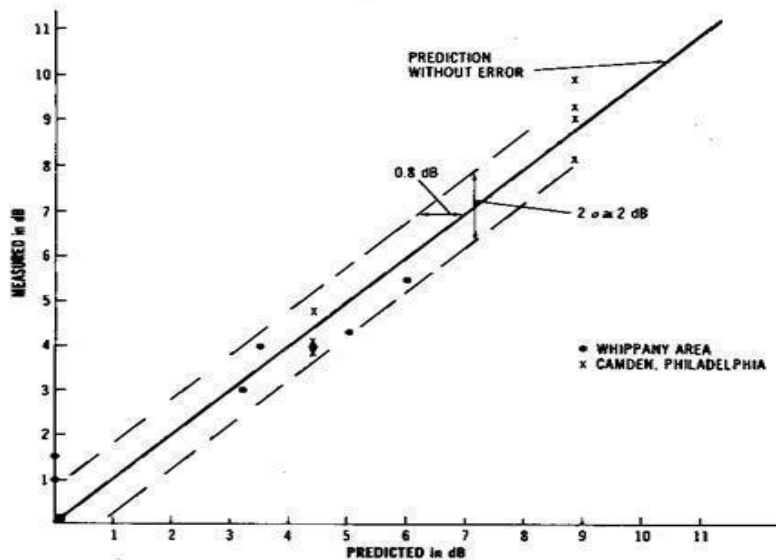

Fig.4. Indication of errors in point-to-point predictions under non obstructive conditions.

FOLIAGE LOSS

Foliage loss is a very complicated topic that has many parameters and variations. The sizes of leaves, branches, and trunks, the density and distribution of leaves, branches, and trunks, and the height of the trees relative to the antenna heights all be considered. An illustration of this prv1em is shown in Fig. 5.1. There are three levels: trunks, branches, and leaves. In each level, there is a distribution of sizes of trunks, branches, and leaves and also of the density and spacing between adjacent trunks, branches, and leaves. The texture and thickness of the leaves also count. This unique problem can become very complicated and is beyond the scope of this book. For a system design, the estimate of the signal reception due to foliage loss does not need any degree of accuracy.

Furthermore, some trees, such as maple or oak, lose their leaves in winter, while others, such as pine, never do. For example, in Atlanta, Georgia, there are oak, maple, and pine trees. In summer the foliage is very heavy, but in winter the leaves of the oak and maple trees fall and the pine leaves stay. In addition, when the length of pine needles reaches approximately 6 in., which is the half wavelength at 800 MHz, a great deal of energy can be absorbed by the pine trees. In these situations, it is very hard to predict the actual foliage loss.

CELLULAR MOBILE COMMUNICATIONS

However, a rough estimate should be sufficient for the purpose of system design. In tropic zones, the sizes of tree leaves are so large and thick that the signal can hardly penetrate. In this case, the signal will propagate from the top of the tree and deflect to the mobile receiver. We will include this calculation also.

Sometime the foliage loss can be treated as a wire-line loss, in decibels per foot or decibels per meter, when the foliage is uniformly heavy and the path lengths are short. When the path length is long and the foliage is non uniform, then decibels per octaves or decibels per decade are used. In general, foliage lose occurs with respect to the frequency to the fourth power. Also, at 800 MHz the foliage Lou along the radio path is 40 dB/dec, which is 20 dB more than the free- space loss, with the same amount of additional loss for mobile communications. Therefore, if the situation involves both foliage loss and mobile communications, the total loss would be 60 dB/dec (=20 dB/ dec of free-space loss + additional 20 dB due to foliage loss + additional 20 dB due to mobile communication).

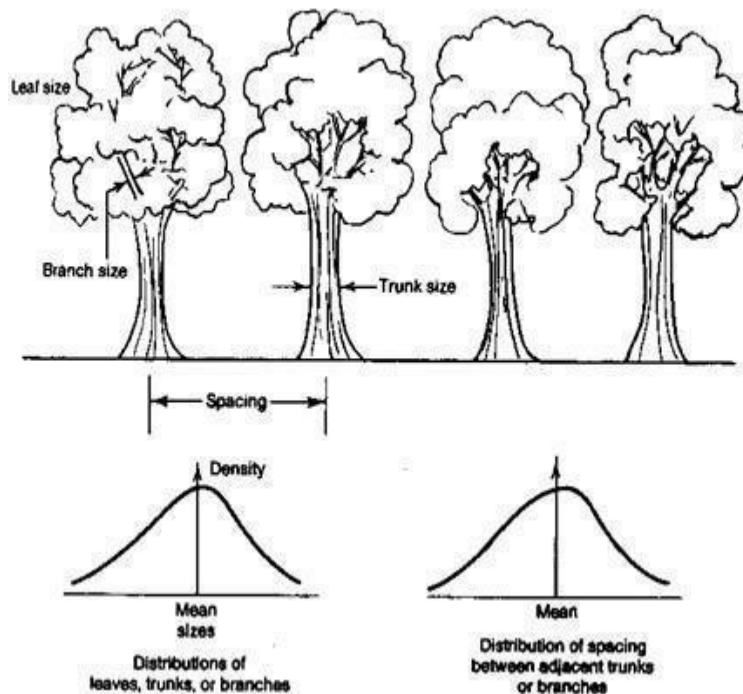

Fig.5.1. A characteristic of foliage environment

This situation would be the case if the foliage would line up along the radio path. A foliage loss in a suburban area of 58.4 dB/dec is shown in Fig.5.2. As demonstrated from the above two examples, close-in foliage at the transmitter site always heavily attenuates signal reception. Therefore, the cell site should be placed away from trees.

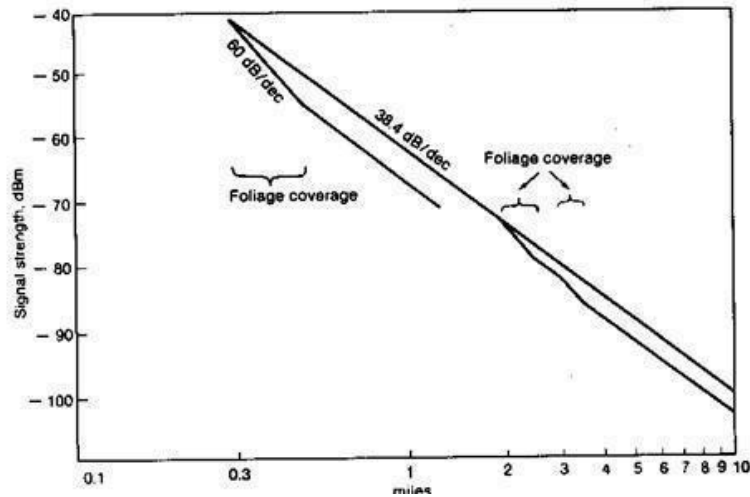

Fig.5.2. Foliage loss calculation in suburban areas

SMALL SCALE MULTIPATH PROPAGATION

The multipath propagation of radio signals over a short period of time or to travel a distance is considered to be the small scale multipath propagation. As every type of multipath propagation results in generating a faded signal at receiver, the small scale multipath propagation also results in small scale fading. Hence, the signal at the receiver is obtained by combining the various multipath waves. These waves will vary widely in amplitude and phase depending on the distribution of the intensity and relative propagation time of the waves and bandwidth of the transmitted signal.

The three fading effects that are generally observed due to the small scale multipath propagation are,

1. Fast variations in signal strength of the transmitted signal for a lesser distance or time interval.
2. The variations in Doppler shift on various multipath signals are responsible for random frequency modulation
3. The time dispersed signals are resulted due to multipath propagation delays.

In order to determine the small scale fading effects, we employ certain techniques. They are,

- D Direct RF pulse measurement
- E Spread spectrum sliding correlation measurement.
- F Swept frequency measurement.

The first technique provides a local average power delay profile.

The second technique detects the transmitted signal with the help of a narrow band receiver preceded by a wide band mixer though the probing (or received) signal is wide band.

CELLULAR MOBILE COMMUNICATIONS

The third technique is helpful in finding the impulse response of the channel in frequency domain. By knowing the impulse response we can easily predict the signal obtained at the receiver from the transmitter.

G Direct RF pulse measurement

H Spread spectrum sliding correlation measurement.

I Swept frequency measurement.

The first technique provides a local average power delay profile.

The second technique detects the transmitted signal with the help of a narrow band receiver preceded by a wide band mixer though the probing (or received) signal is wide band.

The third technique is helpful in finding the impulse response of the channel in frequency domain. By knowing the impulse response we can easily predict the signal obtained at the receiver from the transmitter.

EFFECT OF PROPAGATION OF MOBILE SIGNALS OVER WATER AND FLAT OPEN AREA

PROPAGATION OVER WATER OR FLAT OPEN AREA:

Propagation over water or fiat open area is becoming a big concern because it is very easy to interfere with other cells if we do not make the correct arrangements. Interference resulting from propagation over the water can be controlled if we know the cause. In general, the permittivity's ϵ_r of seawater and fresh water are the same, but the conductivities of seawater and fresh water are different. We may calculate the dielectric constants ϵ_c where $\epsilon_c = \epsilon_r - j60\sigma\lambda$. The wavelength at 850MHz is 0.35m. Then ϵ_o (sea water) = 80 - j84 and ϵ_c (fresh water)=80-j0.021.

However, based upon the reflection coefficients formula with a small incident angle both the reflection coefficients for horizontal polarized waves and vertically polarized waves approach 1. Since the 180° phase change occurs at the ground reflection point, the reflection coefficient is -1. Now we can establish a scenario, as shown in Fig 10.1 Since the two antennas, one at the cell site and the other at the mobile unit, are well above sea level, two reflection points are generated. The one reflected from the ground is close to the mobile unit; the other reflected from the water is away from the mobile unit. We recall that the only reflected wave we considered in the land mobile propagation is the one reflection point which is always very close to the mobile unit. We are now using the formula to find the field strength under the circumstances of a fixed point-to-point transmission and a land-mobile transmission over a water or flat open land condition.

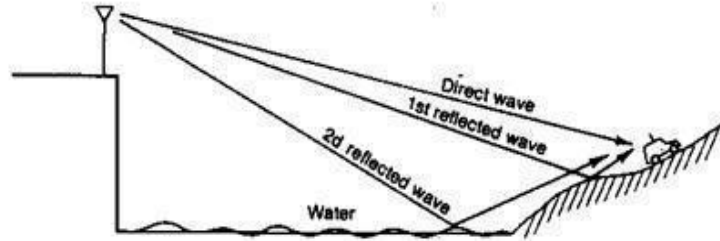

Fig 10.1.A model for propagation over water

BETWEEN FIXED STATIONS: The point-to-point transmission between the fixed stations over the water or flat open land can be estimated as follows. The received power P_r can be expressed as (see Fig.10.2)

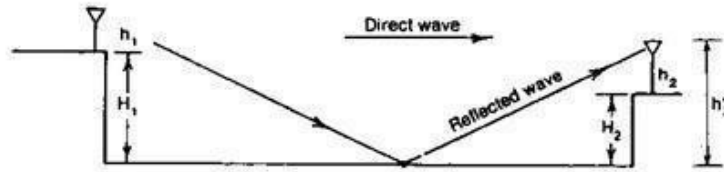

Fig 10.2.Propagation between two fixed stations over water or flat open land.

$$P_r = P_t \left(\frac{1}{4\pi d/\lambda} \right)^2 \left| 1 + a_v e^{-j\phi_v} \exp(j \Delta\phi) \right|^2$$

where P_t = transmitted power
 d = distance between two stations
 λ = wavelength
 a_v, ϕ_v = amplitude and phase of a complex reflection coefficient, respectively

ϕ is the phase difference caused by the path difference M between the direct wave and the reflected wave, or

$$\Delta\phi = \beta \Delta d = \frac{2\pi}{\lambda} \Delta d$$

The first part of i.e. the free-space loss formula which shows the 20 dB/dec slope; that is, a 20-dB loss will be seen when propagating from 1 to 10 km.

$$P_0 = \frac{P_t}{(4\pi d/\lambda)^2}$$

CELLULAR MOBILE COMMUNICATIONS

The complex reflection co-efficient and can be found from the formula

$$a_v e^{-j\phi_v} = \frac{\epsilon_c \sin \theta_1 - (\epsilon_c - \cos^2 \theta_1)^{1/2}}{\epsilon_c \sin \theta_1 + (\epsilon_c - \cos^2 \theta_1)^{1/2}}$$

When the vertical incidence is small, θ is very small and

$$a_v \approx -1 \quad \text{and} \quad \phi_v = 0$$

It can be found from equation. ϵ_c is a dielectric constant that is different for different media. The reflection coefficient remains -1 regardless of whether the wave is propagated over water dry land, wet land, ice, and so forth. The wave propagating between fixed stations is illustrated in Fig. 10.2.

$$P_r = \frac{P_t}{(4\pi d/\lambda)^2} |1 - \cos \Delta\phi - j \sin \Delta\phi|^2$$

$$= P_0(2 - 2 \cos \Delta\phi)$$

since $\Delta\phi$ is a function of d and d can be obtained from the following calculation. The effective antenna height at antenna 1 is the height above the sea level.

$$h'_1 = h_1 + H_1$$

The effective antenna height at antenna 2 is the height above the sea level.

$$h'_2 = h_2 + H_2$$

As shown in Fig.10.2 where h_1 and h_2 are actual heights and H_1 and H_2 are the heights of hills. In general, both antennas at fixed stations are high, so the resection point of the wave will be found toward the middle of the radio path. The path difference d can be obtained from Fig. 10.2 as

$$\Delta d = \sqrt{(h'_1 + h'_2)^2 + d^2} - \sqrt{(h'_1 - h'_2)^2 + d^2}$$

Since $d \gg h'_1$ and h'_2 , then

$$\Delta d \approx d \left[1 + \frac{(h'_1 + h'_2)^2}{2d^2} - 1 - \frac{(h'_1 - h'_2)^2}{2d^2} \right] = \frac{2h'_1 h'_2}{d}$$

Then

$$\Delta\phi = \frac{2\pi}{\lambda} \frac{2h'_1 h'_2}{d} = \frac{4\pi h'_1 h'_2}{\lambda d}$$

MOBILE-TO-MOBILE PROPAGATION

In mobile-to-mobile land communication, both the transmitter and the receiver are in motion. The propagation path in this case is usually obstructed by buildings and obstacles between the transmitter and receiver. The propagation channel acts like a filter with a time-varying transfer function $H(f, t)$ which can be found in this section.

The two mobile units M_1 and M_2 with velocities V_1 and V_2 respectively are shown in Fig.11.1. Assume that the transmitted signal from M_1 is

$$s(t) = u(t)e^{j\omega t}$$

The receiver signal at the mobile unit M_2 from an i th path is

$$s_i = r_i u(t - \tau_i) e^{j[(\omega_0 + \omega_{1i} + \omega_{2i})(t - \tau_i) + \phi_i]}$$

where $u(t)$ = signal

ω_0 = RF carrier

r_i = Rayleigh-distributed random variable

ϕ_i = uniformly distributed random phase

τ_i = time delay on i th path

and

ω_{1i} = Doppler shift of transmitting mobile unit on i th path

$$= \frac{2\pi}{\lambda} V_1 \cos \alpha_{1i}$$

ω_{2i} = Doppler shift of receiving mobile unit on i th path

$$= \frac{2\pi}{\lambda} V_2 \cos \alpha_{2i}$$

Where α_{1i} and α_{2i} are random angles as shown in Fig.11.1. Now assume that the received signal is the summation of n paths uniformly distributed around the azimuth.

$$\begin{aligned} s_r &= \sum_{i=1}^n s_i(t) = \sum_{i=1}^n r_i u(t - \tau_i) \\ &\quad \times \exp \{j[(\omega_0 + \omega_{1i} + \omega_{2i})(t - \tau_i) + \phi_i]\} \\ &= \sum_{i=1}^n Q(\alpha_{i,t}) u(t - \tau_i) e^{j\omega_0 t - \tau_i} \\ \text{where} \quad Q(\alpha_{i,t}) &= r_i \exp \{j[(\omega_{1i} + \omega_{2i})t + \phi'_i]\} \\ \phi'_i &= \phi - (\omega_{1i} + \omega_{2i})\tau_i \end{aligned}$$

UNIT IV (A)

CELLSITE AND MOBILE ANTENNAS

SPACES-DIVERSITY ANTENNAS

Two-branch space-diversity antennas are used at the cell site to receive the same signal with different fading envelopes, one at each antenna. The degree of correlation between two fading envelopes is determined by the degree of separation between two receiving antennas. When the two fading envelopes are combined, the degree of fading is reduced. Here the antenna setup is shown in Fig. 5a.

Equation is presented as an example for the designer to use.

$$\eta = h/D = 11 \quad (8.13-1)$$

Where h is the antenna height and D is the antenna separation. From Eq., the separation $d \geq 8\lambda$ is needed for an antenna height of 100 ft (30 m) and the separation $d \geq 14\lambda$ is needed for an antenna height of 150 ft (50 m). In any Omni cell system, the two space-diversity antennas should be aligned with the terrain, which should have a U shape as shown in Fig.5b. Space-diversity antennas can separate only horizontally, not vertically; thus, there is no advantage in using a vertical separation in the design.

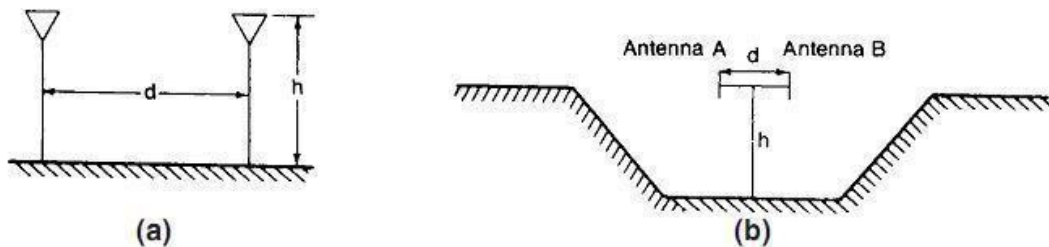

Fig.6.10.Diversity antenna spacing at cell site: (a) $n=h/d$ (b) Proper arrangement with two antennas

UMBRELLAS-PATTERN ANTENNAS

In certain situations, umbrella-pattern antennas should be used for the cell-site antennas.

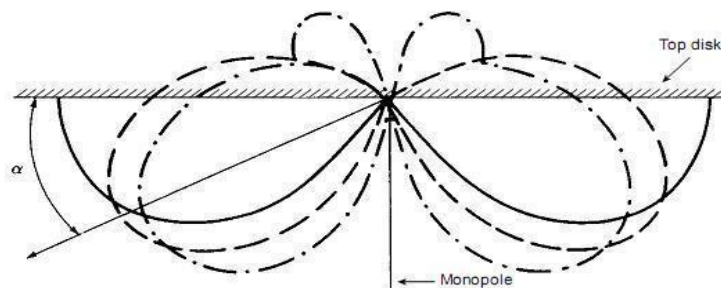

Fig. Vertical-plane patterns of quarter-wavelength stub antenna on infinite ground plane (solid) and on finite ground planes several wavelengths in diameter (dashed line) and about one wavelength in diameter (dotted line).

CELLULAR MOBILE COMMUNICATIONS

i) NORMAL UMBRELLA-PATTERN ANTENNA:

For controlling the energy in a confined area, the umbrella-pattern antenna can be developed by using a monopole with a top disk (top-loading) as shown in Fig. The size of the disk determines the tilting angle of the pattern. The smaller the disk, the larger the tilting angle of the umbrella pattern.

ii) BROADBAND UMBRELLA-PATTERN ANTENNA:

The parameters of a Discone antenna (a bio conical antenna in which one of the cones is extended to 180° to form a disk) are shown in Fig. The diameter of the disk, the length of the cone, and the opening of the cone can be adjusted to create an umbrella-pattern antenna.

iii) INTERFERENCE REDUCTION ANTENNA:

A design for an antenna configuration that reduces interference in two critical directions (areas) is shown in Fig.6.3. The parasitic (insulation) element is about 1.05 times longer than the active element.

iv) HIGH-GAIN BROADBAND UMBRELLA-PATTERN ANTENNA:

A high-gain antenna can be constructed by vertically stacking a number of umbrella-pattern antennas as shown in Fig.

$$E_0 = \frac{\sin[(Nd/2\lambda) \cos \phi]}{\sin[(d/2\lambda) \cos \phi]} \cdot (\text{individual umbrella pattern})$$

where ϕ = direction of wave travel
 N = number of elements
 d = spacing between two adjacent elements

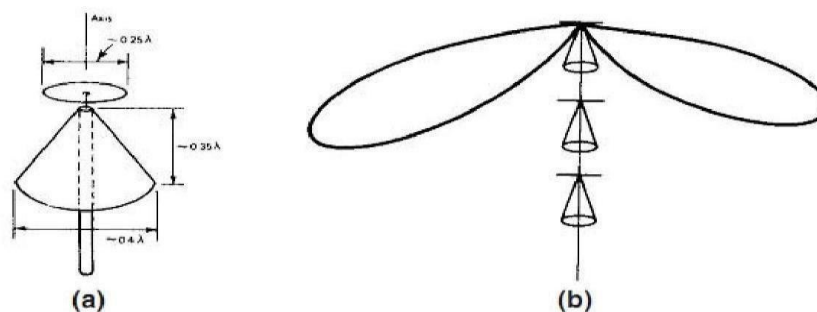

Fig. Discone antennas (a) Single antenna; (b) An array of antenna

MINIMUM SEPARATION OF CELL-SITE RECEIVING ANTENNAS

Separation between two transmitting antennas should be minimized to avoid the inter modulation. The minimum separation between a transmitting antenna and a receiving antenna is necessary to avoid receiver

CELLULAR MOBILE COMMUNICATIONS

desensitization. Here we are describing a minimum separation between two receiving antennas to reduce the antenna pattern ripple effects. The two receiving antennas are used for a space-diversity receiver.

Because of the near field disturbance due to the close spacing, ripples will form in the antenna patterns (Fig.). The difference in power reception between two antennas at different angles of arrival is shown in Fig. . If the antennas are located closer; the difference in power between two antennas at a given pointing angle increases. Although the power difference is confined to a small sector, it affects a large section of the street as shown in Fig. .

If the power difference is excessive, use of space diversity will have no effect reducing fading. At 850 MHz, the separation of eight wavelengths between two receiving antennas creates a power difference of ± 2 dB, which is tolerable for the advantageous use of a diversity scheme.

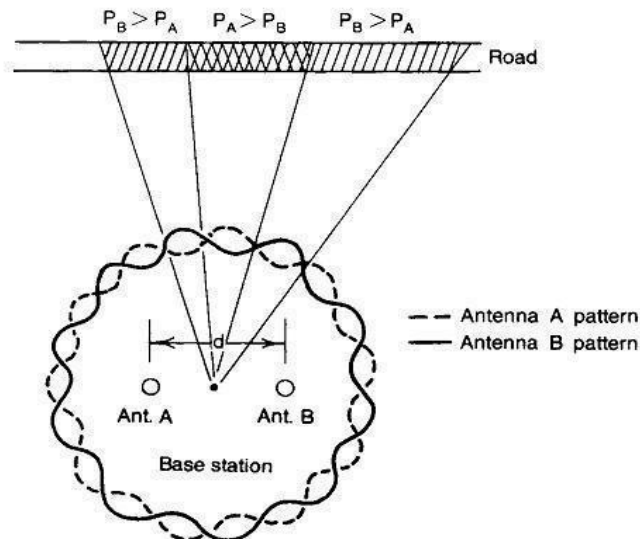

Fig. Antenna pattern ripple effect

MOBILE ANTENNAS

The requirement of a mobile (motor-vehicle-mounted) antenna is an Omni-directional antenna that can be located as high as possible from the point of reception. However, the physical limitation of antenna height on the vehicle restricts this requirement. Generally, the antenna should at least clear the top of the vehicle. Patterns for two types of mobile antenna are shown in Fig.

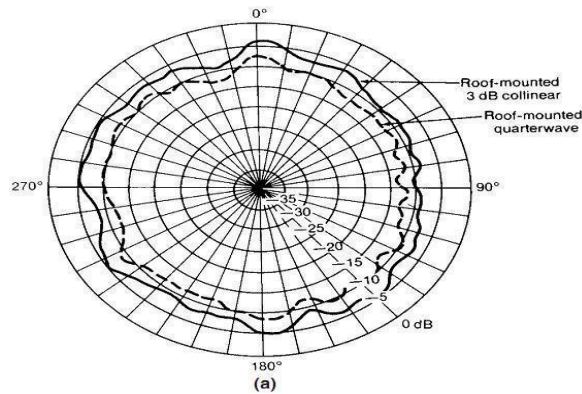

Fig. Mobile antenna patterns (a) Roof mounted 3-dB-gain collinear antenna versus roof-mounted quarter-wave antenna, (b) Window-moured “on-glass” gain antenna versus roof-mounted quarter-wave antenna.

ROOF-MOUNTED ANTENNA:

The antenna pattern of a roof-mounted antenna is more or less uniformly distributed around the mobile unit when measured at an antenna range in free space as shown in Fig.9.2. The 3-dB high-gain antenna shows a 3-dB gain over the quarter-wave antenna. However, the gain of the antenna used at the mobile unit must be limited to 3 dB because the cell-site antenna is rarely as high as the broadcasting antenna and out-of-sight conditions often prevail. The mobile antenna with a gain of more than 3 dB can receive only a limited portion of the total multipath signal in the elevation as measured under the out-of-sight condition.

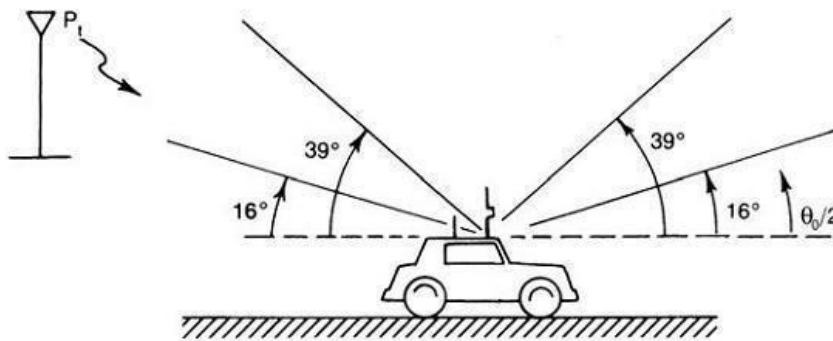

Fig. Vertical angle of signal arrival

GLASS-MOUNTED ANTENNAS:

There are many kinds of glass-mounted antennas. Energy is coupled through the glass; therefore, there is no need to drill a hole. However, some energy is dissipated on passage through the glass. The antenna gain range is 1 to 3 dB depending on the operating frequency. The position of the glass-mounted antenna is

CELLULAR MOBILE COMMUNICATIONS

always lower than that of the roof-mounted antenna; generally there is a 3-dB difference between these two types of antenna. Also, glass mounted antennas cannot be installed on the shaded glass found in some motor vehicles because this type of glass has a high metal content.

MOBILE HIGH-GAIN ANTENNAS:

A high-gain antenna used on a mobile unit has been studied. This type of high-gain antenna should be distinguished from the directional antenna. In the directional antenna, the antenna beam pattern is suppressed horizontally; in the high-gain antenna, the pattern is suppressed vertically.

To apply either a directional antenna or a high-gain antenna for reception in a radio environment, we must know the origin of the signal. If we point the directional antenna opposite to the transmitter site, we would in theory receive nothing. In a mobile radio environment, the scattered signals arrive at the mobile unit from every direction with equal probability. That is why an Omni directional antenna must be used.

The scattered signals also arrive from different elevation angles. Lee and Brandt used two types of antenna, one $\lambda/4$ whip antenna with elevation coverage of 39° and one 4-dB-gain antenna (4-dB gain with respect to the gain of a dipole) with elevation coverage of 16° and measured the angle of signal arrival in the suburban Keyport-Matawan area of New Jersey. There are two types of test: a line-of-sight condition and an out-of-sight condition. In Lee and Brandt's study, the transmitter was located at an elevation of approximately 100 m (300 ft) above sea level.

The measured areas were about 12 m (40 ft) above sea level and the path length about 3 mi. The received signal from the 4-dB-gain antenna was 4 dB stronger than that from the whip antenna under line-of-sight conditions. This is what we would expect.

However, the received signal from the 4-dB-gain antenna was only about 2 dB stronger than that from the whip antenna under out-of-sight conditions. This is surprising. The reason for the latter observation is that the scattered signals arriving under out-of-sight conditions are spread over a wide elevation angle. A large portion of the signals outside the elevation angle of 16° cannot be received by the high-gain antenna. We may calculate the portion being received by the high-gain antenna from the measured beam width. For instance, suppose that a 4:1 gain (6 dBi) is expected from the high-gain antenna, but only 2.5:1 is received. Therefore, 63 percent of the signal is received by the 4-dB-gain antenna (i.e., 6 dBi) and 37 percent is felt in the region between 16° and 39° .

Therefore, a 2- to 3-dB-gain antenna (4 to 5 dBi) should be adequate for general use. An antenna gain higher than 2 to 3 dB does not serve the purpose of enhancing reception level. Moreover, measurements reveal that the elevation angle for scattered signals received in urban areas is greater than that in suburban areas.

CELLULAR MOBILE COMMUNICATIONS

	Gain, dBi	Linear ratio	$\theta_0/2$, degrees
Whip antenna (2 dB above isotropic)	2	1.58:1	39
High-gain antenna	6	4:1	16
Low-gain antenna	4	2.5:1	24

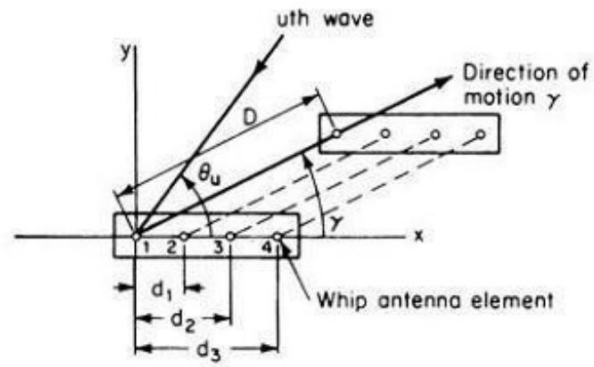

UNIT-IV (B)

FREQUENCY MANAGEMENT AND CHANNEL ASSIGNMENT

The function of frequency management is to divide the total number of available channels into subsets which can be assigned to each cell either in a fixed fashion or dynamically (i.e., in response to any channel among the available channels). The terms —frequency management|| and —channel assignment|| often create some confusion. Frequency management refers to designating setup channels and voice channels (done by the FCC), numbering the channels (done by the FCC), and grouping the voice channels into subsets (done by each system according to its preference).

Channel assignment refers to the allocation of specific channels to cell sites and mobile units. A fixed channel set consisting of one more subsets is assigned to a cell site on a long-term basis. During a call, a particular channel is assigned to a mobile unit on a short- term basis. For a short-term assignment, one channel assignment per call is handled by the mobile telephone switching office (MTSO). Ideally channel assignment should be based on causing the least interference in the system. However, most cellular systems cannot perform this way.

4.1 NUMBERING THE RADIO CHANNELS

The total number of channels at present (January 1988) is 832. But most mobile units an systems are still operating on 666 channels. Therefore we describe the 666 channel numbering first. A channel consists of two frequency channel bandwidths, one in the low band and one in the high band. Two frequencies in channel 1 are 825.030 MHz (mobile transmit) 870.030 MHz (cell-site transmit). The two frequencies in channel 666 are 844.98 MHz (mobile transmit) and 898 MHz (cell-site transmit). The 666 channels are divided into two groups: block A system and block B system. Each market (i.e., each city) has two systems for a duopoly market policy. Each block has 333 channels, as shown in Fig.1.1.

The 42 set-up channels are assigned as follows.

Channels 313-333	block A
Channels 334-354	block B

The voice channels are assigned as follows.

	block
Channels 1-312 (312 voice channels)	A
	block
Channels 355-666 (312 voice channels)	B

CELLULAR MOBILE COMMUNICATIONS

1A	2A	3A	4A	5A	6A	7A	1B	2B	3B	4B	5B	6B	7B	1C	2C	3C	4C	5C	6C	7C
1	2	3	4	5	6	7	8	9	10	11	12	13	14	15	16	17	18	19	20	21
22	23	24	25	26	27	28	29	30	31	32	33	34	35	36	37	38	39	40	41	42
43	44	45	46	47	48	49	50	51	52	53	54	55	56	57	58	59	60	61	62	63
64	65	66	67	68	69	70	71	72	73	74	75	76	77	78	79	80	81	82	83	84
85	86	87	88	89	90	91	92	93	94	95	96	97	98	99	100	101	102	103	104	106
106	107	108	109	110	111	112	113	114	115	116	117	118	119	120	121	122	123	124	125	126
127	128	129	130	131	132	133	134	135	136	137	138	139	140	141	142	143	144	145	146	147
148	149	150	151	152	153	154	155	156	157	158	159	160	161	162	163	164	165	166	167	168
169	170	171	172	173	174	175	176	177	178	179	180	181	182	183	184	185	186	187	188	189
190	191	192	193	194	195	196	197	198	199	200	201	202	203	204	205	206	207	208	209	210
211	212	213	214	215	216	217	218	219	220	221	222	223	224	225	226	227	228	229	230	231
232	233	234	235	236	237	238	239	240	241	242	243	244	245	246	247	248	249	250	251	252
253	254	255	256	257	258	259	260	261	262	263	264	265	266	267	268	269	270	271	272	273
274	275	276	277	278	279	280	281	282	283	284	285	286	287	288	289	290	291	292	293	294
295	296	297	298	299	300	301	302	303	304	305	306	307	308	309	310	311	312	—	—	—
313	314	315	316	317	318	319	320	321	322	323	324	325	326	327	328	329	330	331	332	333
334	335	336	337	338	339	340	341	342	343	344	345	346	347	348	349	350	351	352	353	354
355	356	357	358	359	360	361	362	363	364	365	366	367	368	369	370	371	372	373	374	375
376	377	378	379	380	381	382	383	384	385	386	387	388	389	390	391	392	393	394	395	396
397	398	399	400	401	402	403	404	405	406	407	408	409	410	411	412	413	414	415	416	417
418	419	420	421	422	423	424	425	426	427	428	429	430	431	432	433	434	435	436	437	438
439	440	441	442	443	444	445	446	447	448	449	450	451	452	453	454	455	456	457	458	459
460	461	462	463	464	465	466	467	468	469	470	471	472	473	474	475	476	477	478	479	480
481	482	483	484	485	486	487	488	489	490	491	492	493	494	495	496	497	498	499	500	501
502	503	504	505	506	507	508	509	510	511	512	513	514	515	516	517	518	519	520	521	522
523	524	525	526	527	528	529	530	531	532	533	534	535	536	537	538	539	540	541	542	543
544	545	546	547	548	549	550	551	552	553	554	555	556	557	558	559	560	561	562	563	564
565	566	567	568	569	570	571	572	573	574	575	576	577	578	579	580	581	582	583	584	585
586	587	588	589	590	591	592	593	594	595	596	597	598	599	600	601	602	603	604	605	606
607	608	609	610	611	612	613	614	615	616	617	618	619	620	621	622	623	624	625	626	627
628	629	630	631	632	633	634	635	636	637	638	639	640	641	642	643	644	645	646	647	648
649	650	651	652	653	654	655	656	657	658	659	660	661	662	663	664	665	666	—	—	—

Fig.4.1. Frequency management chart

These 42 set-up channels are assigned in the middle of all the assigned channels to facilitate scanning of those channels by frequency synthesizers. In the new additional spectrum allocation of 10 MHz (see Fig. 1.2.), an additional 166 channels are assigned. Since a 1 MHz is assigned below 825 MHz (or 870 MHz) in the future, additional channels will be numbered up to 849 MHz (or 894 MHz) and will then circle back. The last channel number is 1023. There are no channels between channels 799 and 991.

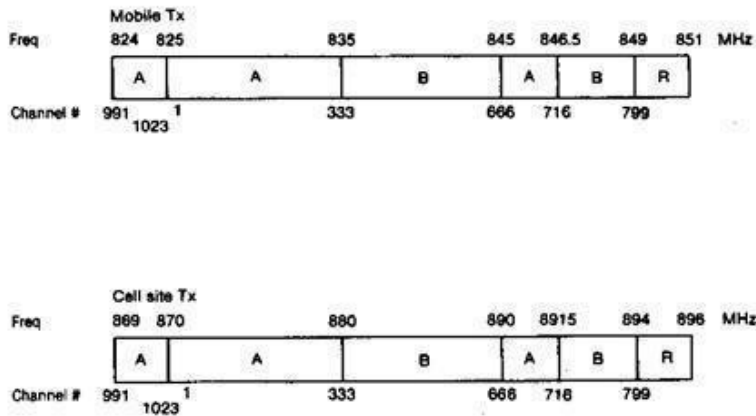

Fig.4.2. New additional spectrum allocation

CELLULAR MOBILE COMMUNICATIONS

4.2 GROUPING INTO SUBSETS

The number of voice channels for each system is 312. We can group these into any number of subsets. Since there are 21 set-up channels for each system, it is logical to group the 312 channels into 21 subsets. Each subset then consists of 16 channels. In each set, the closest adjacent channel is 21 channels away, as shown in Fig.1.1. The 16 channels in each subset can be mounted on a frame and connected to a channel combiner. Wide separation between adjacent channels is required for meeting the requirement of minimum isolation. Each 16-channel subset is idealized for each 16-channel combiner. In a seven-cell frequency-reuse cell system each cell contains three subsets, $iA+iB+iC$, where i is an integer from 1 to 7. The total number of voice channels in a cell is about 45. The minimum separation between three subsets is 7 channels. If six subsets are equipped in an omniscell site, the minimum separation between two adjacent channels can be only three ($21/6 > 3$) physical channel bandwidths.

For example,

$$1A+1B+1C+4A+4B$$

$$+4C$$

Or

$$1A+1B+1C+5A+5B+5C$$

4.3 SET-UP CHANNELS

Set-up channels also called control channels are the channels designated to setup calls. We should not be confused by fact that a call always needs a set-up channel. A system can be operated without set-up channels. If we are choosing such a system all the 333 channels in each cellular system (block A or block B) can be voice channels; however each mobile unit must then scan 333 channels continuously and detect the signaling for its call. A customer who wants to initiate a call must scan all the channels and find an idle (unoccupied) one to use.

In a cellular system, we are implementing frequency-reuse concepts. In this case the set-up channels are acting as control channels. The 21 set-up channels are taken out from the total number of channels. The number 21 is derived from a seven-cell frequency-reuse pattern with three 120° sectors per cell, or a total of 21 sectors, which require 21 set-up channels. However, now only a few of the 21 setup channels are being used in each system. Theoretically, when cell size decreases the use of set-up channels should increase. Set-up channels can be classified by usage into two types: access channels and paging channels.

An access channel is used for the mobile-originating calls and paging channels for the land originating calls. For this reason, a set-up channel is sometimes called an 'access channel' and sometimes called a 'paging channel.' Every two-way channel contains two 30-kHz bandwidths. Normally one set-up channel is also specified

CELLULAR MOBILE COMMUNICATIONS

by two operations as a forward set-up channel (using the upper band) and a reverse set-up channel (using the lower band). In the most common types of cellular systems, one set-up channel is used for both access and paging. The forward set-up channel functions as the paging channel for responding to the mobile-originating calls. The reverse set-up channel functions as the access channel for the responder to the paging call. The forward set-up channel is transmitted at the cell site, and the reverse set-up channel is transmitted at the mobile unit. All set-up channels carry data information only.

4.3.1. ACCESS CHANNELS:

In mobile-originating calls, the mobile unit scans its 21 set-up channels and chooses the strongest one. Because each set-up channel is associated with one cell, the strongest set-up channel indicates which cell is to serve the mobile-originating calls. The mobile unit detects the system information transmitted from the cell site. Also, the mobile unit monitors the Busy/Idle status bits over the desired forward setup channel. When the idle bits are received, the mobile unit can use the corresponding reverse set-up channel to initiate a call.

Frequently only one system operates in a given city; for instance, block B system might be operating and the mobile unit could be set to —preferable A system. When the mobile unit first scans the 21 set-up channels in block A, two conditions can occur.

1. If no set-up channels of block A are operational, the mobile unit automatically switches to block B.
2. If a strong set-up signal strength is received but no message can be detected, then the scanner chooses the second strongest set-up channel. If the message still cannot be detected, the mobile unit switches to block B and scans to block B set-up channels.

THE OPERATIONAL FUNCTIONS ARE DESCRIBED AS FOLLOWS:

1. POWER OF A FORWARD SET-UP CHANNEL [OR FORWARD CONTROL CHANNEL (FOCC)]: The power of the set-up channel can be varied in order to control the number of incoming calls served by the cell. The number of mobile-originating calls is limited by the number of voice channels in each cell site, when the traffic is heavy, most voice channels are occupied and the power of the set-up channel should be reduced in order to reduce the coverage of the cell for the incoming calls originating from the mobile unit. This will force the mobile units to originate calls from other cell sites, assuming that all cells are adequately overlapped.

2. THE SET-UP CHANNEL RECEIVED LEVEL: The setup channel threshold level is determined in order to control the reception at the reverse control channel (RECC). If the received power level is greater than the given set-up threshold level, the call request will be taken.

CELLULAR MOBILE COMMUNICATIONS

3. CHANGE POWER AT THE MOBILE UNIT: When the mobile unit monitors the strongest signal strength from all Set-up channels and selects that channel to receive the messages, there are three types of message.

A. MOBILE STATION CONTROL MESSAGE. This message is used for paging and consists of one, two, or four words -DCC, MIN, SCC and VMAX.

B. SYSTEM PARAMETER OVERHEAD MESSAGE. This message contains two words, including DCC, SID, CMAX, or CPA.

c. CONTROL-FILLER MESSAGE. This message may be sent with a system parameter overhead message, CMAC—a control mobile attenuation code (seven levels).

4. DIRECT CALLS RETRY. When a cell site has no available voice channels, it can send a direct call-retry message through the set-up channel. The mobile unit will initiate, the call from a neighboring cell which is on the list of neighboring cells in the direct call-retry message.

4.3.2. PAGING CHANNELS:

Each cell site has been allocated its own setup channel (control channel). The assigned forward set-up channel (FOCC) of each cell site is used to page the mobile unit with the same mobile station control message.

Because the same message is transmitted by the different set-up channels, no simulcast interference occurs in the system. The algorithm for paging & mobile unit can be performed in different ways. The simplest way is to page from all the cell sites. This can occupy a large amount of the traffic load. The other way is to page in an area corresponding to the mobile unit phone number. If there is no answer, the system tries to page in other areas. The drawback is that response time is sometimes too long.

When the mobile unit responds to the page on the reverse set-up channel, the cell site which receives the response checks the signal reception level and makes a decision regarding the voice channel assignment based on least interference in the selected sector or underlay-overlay region.

4.4 FIXED CHANNEL ASSIGNMENT

ADJACENT-CHANNEL ASSIGNMENT:

Adjacent-channel assignment includes neighboring-channel assignment and next-channel assignment. The near-end–far-end (ratio) interference can occur among the neighboring channels (four channels on each side of the desired channel). Therefore, within a cell we have to be sure to assign neighboring channels in an Omni-directional-cell system and in a directional-antenna-cell system properly.

In an Omni-directional-cell system, if one channel is assigned to the middle cell of seven cells, next channels cannot be assigned in the same cell. Also, no next channel (preferably including neighboring channels) should be assigned in the six neighboring sites in the same cell system area (Fig. 7.3a). In a directional-antenna-

CELLULAR MOBILE COMMUNICATIONS

cell system, if one channel is assigned to a face, next channels cannot be assigned to the same face or to the other two faces in the same cell. Also, next channels cannot be assigned to the other two faces at the same cell site (Fig. 7.3b). Sometimes the next channels are assigned in the next sector of the same cell in order to increase capacity. Then performance can still be in the tolerance range if the design is proper.

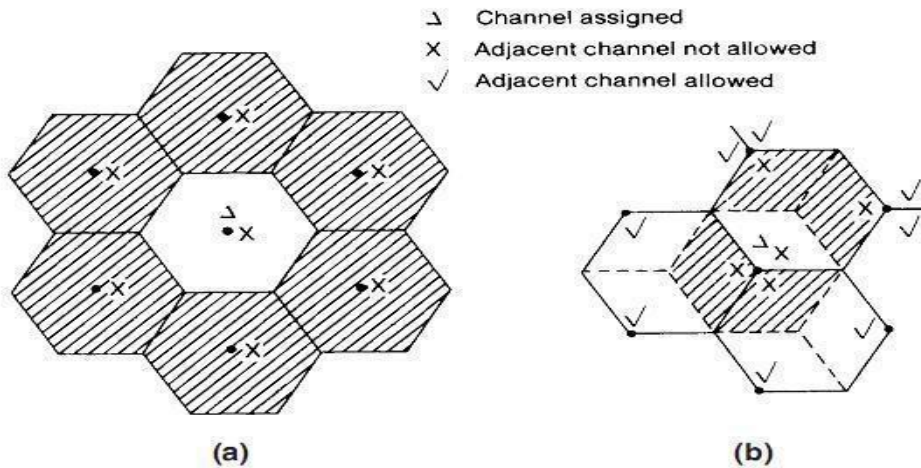
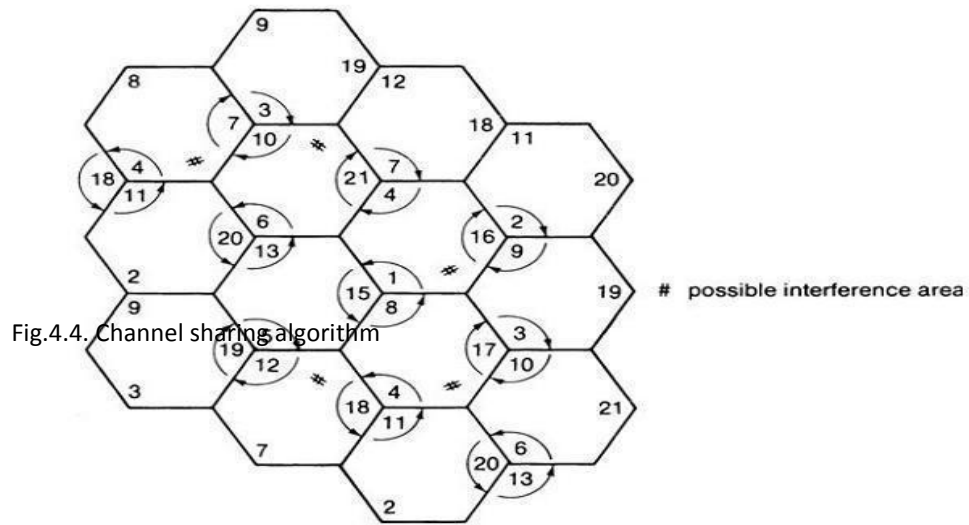

Fig.4.3 Adjacent channel assignment (a) Omni direction antenna cells; (b) Directional antenna cells

4.5 CHANNEL SHARING

Channel sharing is a short-term traffic-relief scheme. A scheme used for a seven-cell three-face system is shown in Fig. 7.2. There are 21 channel sets, with each set consisting of about 16 channels. Figure 7.2 shows the channel set numbers. When a cell needs more channels, the channels of another face at the same cell site can be shared to handle the short-term overload. To obey the adjacent-channel assignment algorithm, the sharing is always cyclic. Sharing always increases the trunking efficiency of channels.

Since we cannot allow adjacent channels to share with the nominal channels in the same cell, channel sets 4 and 5 cannot both be shared with channel sets 12 and 18, as indicated by the grid mark. Many grid marks are indicated in Fig. 7.2 for the same reason. However, the upper subset of set 4 can be shared with the lower subset of set 5 with no interference. In channel-sharing systems, the channel combiner should be flexible in order to combine up to 32 channels in one face in real time. An alternative method is to install a standby antenna.



4.6 CHANNEL BORROWING

Channel borrowing is usually handled on a long-term basis. The extent of borrowing more available channels from other cells depends on the traffic density in the area. Channel borrowing can be implemented from one cell-site face to another face at the same cell site. In addition, the central cell site can borrow channels from neighboring cells. The channel-borrowing scheme is used primarily for slowly-growing systems. It is often helpful in delaying cell splitting in peak traffic areas. Since cell splitting is costly, it should be implemented only as a last resort.

ADVANTAGE OF SECTORIZATION:

The total number of available channels can be divided into sets (subgroups) depending on the Sectorization of the cell configuration: the 120°-sector system, the 60°-sector system, and the 45°-sector system. In certain locations and special situations, the sector angle can be reduced (narrowed) in order to assign more channels in one sector without increasing neighboring-channel interference. Sectorization serves the same purpose as the channel-borrowing scheme in delaying cell splitting. In addition, channel coordination to avoid co-channel interference is much easier in sectorization than in cell splitting. Given the same number of channels, trunking efficiency decreases in Sectorization.

SECTORIZED CELLS: There are three basic types.

1. The 120°-sector cell is used for both transmitting and receiving Sectorization. Each sector has an assigned a number of frequencies. Changing sectors during a call requires handoffs.
2. The 60°-sector cell is used for both transmitting and receiving Sectorization. Changing sectors during a call requires handoffs. More handoffs are expected for a 60° sector than a 120° sector in areas close to cell sites (close-in areas).

CELLULAR MOBILE COMMUNICATIONS

3. The 120° or 60°-sector cell is used for receiving Sectorization only. In this case, the transmitting antenna is Omni directional. The number of channels in this cell is not sub- divided for each sector. Therefore, no handoffs are required when changing sectors. This receiving-Sectorization-only configuration does not decrease interference or increase the D/R ratio; it only allows for a more accurate decision regarding handing off the calls to neighboring cells.

4.7 UNDERLAY-OVERLAY ARRANGEMENT

In actual cellular systems cell grids are seldom uniform because of varying traffic conditions in different areas and cell-site locations.

OVERLAID CELLS:

To permit the two groups to reuse the channels in two different cell-reuse patterns of the same size, an under laid small cell is sometimes established at the same cell site as the large cell (see Fig. 7.5a). The large and small cells are treated as two different cells. They are usually considered as neighboring cells.

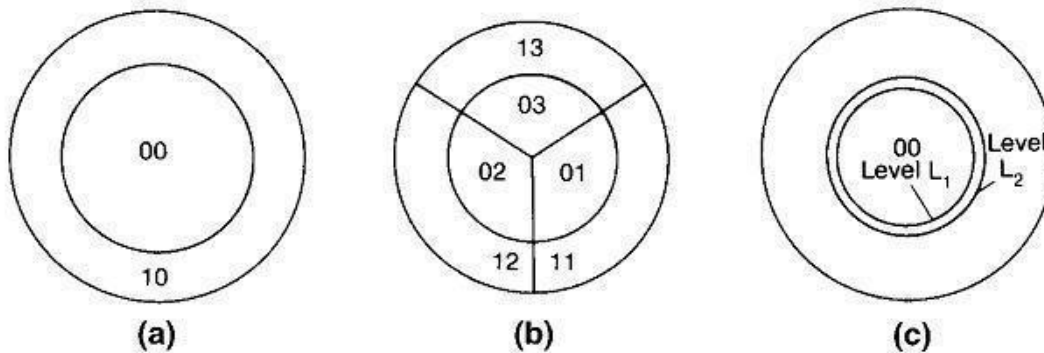

Fig.4.5. Under laid-overlaid cell arrangements. (a) Underlay-overlay in omniscell; (b) Underlay-overlay in Sectorized cell; (c) Two level handoff scheme

The use of either an Omni directional antenna at one site to create two sub ring areas or three directional antennas to create six subareas is illustrated in Fig. 4.5 b. As seen in Fig.4.5, a set of frequencies used in an overlay area will differ from a set of frequencies used in an underlay area in order to avoid adjacent-channel and co-channel interference.

The channels assigned to one combiner—say, 16 channels—can be used for overlay, and another combiner can be used for underlay.

IMPLEMENTATION:

The antenna of a set-up channel is usually Omni directional. When an incoming call is received by the set-up channel and its signal strength is higher than a level L, the under laid cell is assigned; otherwise, the overlaid cell is

assigned. The handoffs are implemented between the under laid and overlaid cells. In order to avoid the unnecessary handoffs, we may choose two levels L1 and L2 and $L1 > L2$ as shown in Fig. 4.5 (c). When a mobile signal is higher than a level L1 the call is handed off to the under laid cell. When a signal is lower than a level L2 the call is handed off to the overlaid cell. The channels assigned in the under laid cell have more protection against co-channel interference.

4.8 NON FIXED CHANNEL ASSIGNMENT STRATEGY

1. FIXED CHANNEL ASSIGNMENT: The fixed channel assignment (FCA) algorithm is the most common algorithm adopted in many cellular systems. In this algorithm, each cell assigns its own radio channels to the vehicles within its cell.

2. DYNAMIC CHANNEL ASSIGNMENT: In dynamic channel assignment (DCA), no fixed channels are assigned to each cell. Therefore, any channel in a composite of N radio channels can be assigned to the mobile unit. This means that a channel is assigned directly to a mobile unit. On the basis of overall system performance, DCA can also be used during a call.

3. HYBRID CHANNEL ASSIGNMENT: Hybrid channel assignment (HCA) is a combination of FCA and DCA. A portion of the total frequency channels will use FCA and the rest will use DCA.

4. BORROWING CHANNEL ASSIGNMENT: Borrowing channel assignment (BCA) uses FCA as a normal assignment condition. When all the fixed channels are occupied, then the cell borrows channels from the neighboring cells.

5. FORCIBLE-BORROWING CHANNEL ASSIGNMENT: In forcible-borrowing channel assignment (FBCA), if a channel is in operation and the situation warrants it, channels must be borrowed from the neighboring cells and at the same time, another voice channel will be assigned to continue the call in the neighboring cell. There are many different ways of implementing FBCA. In a general sense, FBCA can also be applied while accounting for the forcible borrowing of the channels within a fixed channel set to reduce the chance of co-channel assignment in a reuse cell pattern. The FBCA algorithms based on assigning a channel dynamically but obeying the rule of reuse distance.

The distance between the two cells is reuse distance, which is the minimum distance at which no co-channel interference would occur. Very infrequently, no channel can be borrowed in the neighboring cells. Even those channels currently in operation can be forcibly borrowed and will be replaced by a new channel in the neighboring cell or the neighboring cell of the neighboring cell. If all the channels in the neighboring cells cannot be borrowed because of interference problems, the FBCA stops.

CELLULAR MOBILE COMMUNICATIONS

UNIT-V

HANDOFFS

WHY HAND OFF IS NECESSARY

In an analog system, once a call is established, the set-up channel is not used again during the call period. Therefore, handoff is always implemented on the voice channel. In the digital systems, the handoff is carried out through paging or common control channel. The value of implementing handoffs is dependent on the size of the cell. For example, if the radius of the cell is 32 km (20 mi), the area is 3217 km²(1256 mi²). After a call is initiated in this area, there is little chance that it will be dropped before the call is terminated as a result of a weak signal at the coverage boundary. Then why bother to implement the handoff feature? Even for a 16-km radius, cell handoff may not be needed. If a call is dropped in a fringe area, the customer simply redials and reconnects the call. Today the size of cells becomes smaller in order to increase capacity. Also people talk longer. The handoffs are very essential. Handoff is needed in two situations where the cell site receives weak signals from the mobile unit: (1) at the cell boundary, say, -100 dBm, which is the level for requesting a handoff in a noise-limited environment; and (2) when the mobile unit is reaching the signal-strength holes (gaps) within the cell site as shown in Fig.1.

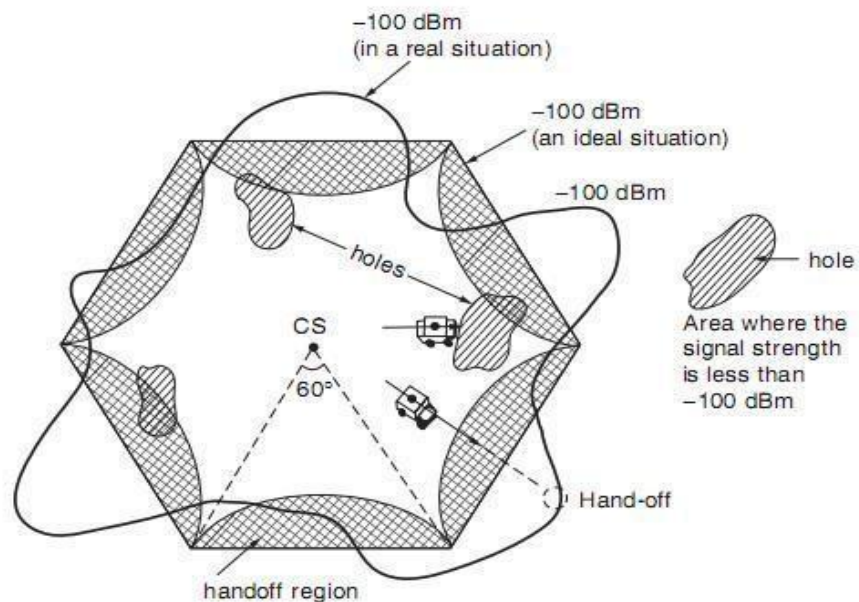

Fig.1. Occurrence of handoffs

WHAT ARE THE TWO DECISION MAKING PARAMETERS OF HANDOFF EXPLAIN

There are two decision-making parameters of handoff: (1) that based on signal strength and (2) that based on carrier-to-interference ratio. The handoff criteria are different for these two types. In type 1, the

CELLULAR MOBILE COMMUNICATIONS

signal-strength threshold level for handoff is -100 dBm in noise-limited systems and -95 dBm in interference-limited systems. In type 2, the value of C/I at the cell boundary for handoff should be at a level, 18 dB for AMPS in order to have toll quality voice. Sometimes, a low value of C/I may be used for capacity reasons.

Type 1: It is easy to implement. The location receiver at each cell site measures all the signal strengths of all receivers at the cell site. However, the received signal strength (RSS) itself includes interference.

$$RSS = C + I$$

where C is the carrier signal power and I is the interference. Suppose that we set up a threshold level for RSS; then, because of the I , which is sometimes very strong, the RSS level is higher and far above the handoff threshold level. In this situation handoff should theoretically take place but does not. Another situation is when I is very low but RSS is also low. In this situation, the voice quality usually is good even though the RSS level is low, but since RSS is low, unnecessary handoff takes place. Therefore, it is an easy but not very accurate method of determining handoffs. Some analog systems use SAT information together with the received signal level to determine handoffs. Some CDMA systems use pilot channel information.

Type 2: Handoffs can be controlled by using the carrier-to-interference ratio C/I $C+I/I = C/I$

we can set a level based on C/I , so C drops as a function of distance but I is dependent on the location. If the handoff is dependent on C/I , and if the C/I drops, it does so in response to increase in (1) propagation distance or (2) interference. In both cases, handoff should take place. In today's cellular systems, it is hard to measure C/I during a call because of analog modulation. Sometimes we measure the level I before the call is connected, and the level $C + I$ during the call. Thus $(C + I)/I$ can be obtained.

TYPES OF HANDOFF

There are four types of handoff:

1. INTERSECTOR OR SOFTER HANDOFF.

The mobile communicates with two sectors of the same cell (see Fig. 10-1). A RAKE receiver at the base station combines the best versions of the voice frame from the diversity antennas of the two sectors into a single traffic frame.

2. INTERCELL OR SOFT HANDOFF.

The mobile communicates with two or three sectors of different cells (see Fig. 10-2). The base station that has the direct control of call processing during handoff is referred to as the primary base station. The primary base station can initiate the forward control message. Other base stations that do not have control over call processing are called the secondary base stations. Soft handoff ends when either the primary or secondary base station is dropped. If the primary base station is dropped, the secondary base station becomes the new primary for this call. A three-way soft handoff may end by first dropping one of the base stations and becoming a two-way soft handoff. The base stations involved coordinate handoff by

CELLULAR MOBILE COMMUNICATIONS

exchanging information via SS7 links. A soft handoff uses considerably more network resources than the softer handoff.

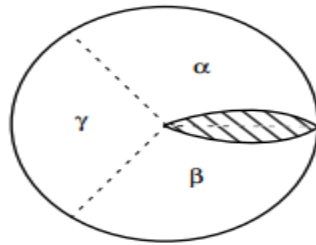

Figure 10-1 Softer Handoff

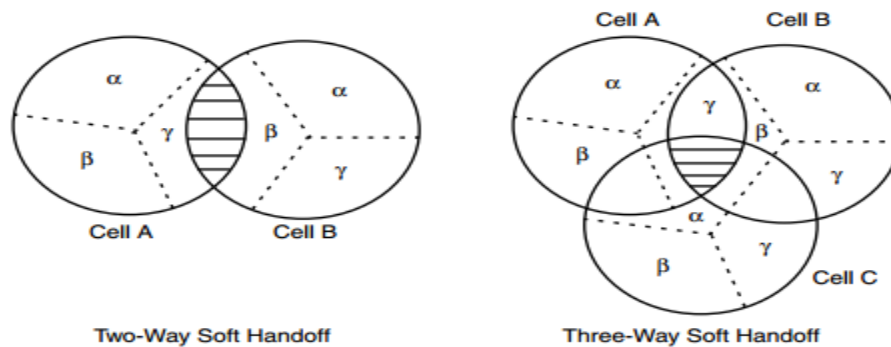

Figure 10-2 Soft Handoff

3. SOFT-SOFTER HANDOFF.

The mobile communicates with two sectors of one cell and one sector of another cell (see Fig. 10-3). Network resources required for this type of handoff include the resources for a two-way soft handoff between cell A and B plus the resources for a softer handoff at cell B.

4. HARD HANDOFF.

Hard handoffs are characterized by the break-before-make strategy. The connection with the old traffic channel is broken before the connection with the new traffic channel is established. Scenarios for hard handoff include

- ◆ Handoff between base stations or sectors with different CDMA carriers
- ◆ Change from one pilot to another pilot without first being in soft handoff with the new pilot (disjoint active sets)
- ◆ Handoff from CDMA to analog, and analog to CDMA
- ◆ Change of frame offset assignment—CDMA traffic frames are 20 ms long. The start of frames in a particular traffic channel can be at 0 time in reference to a system or it can be offset by up to 20 ms (allowed in IS-95). This is known as the frame offset. CDMA traffic channels are assigned different frame offset to avoid congestion. The frame offset for a particular traffic channel is communicated to the mobile. Both forward and reverse links use this offset. A change in offset

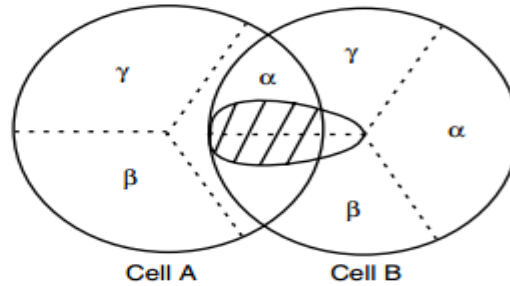

Figure 10-3 Soft-Softer Handoff

Assignment will disrupt the link. During soft handoff the new base station must allocate the same frame offset to the mobile as assigned by the primary base station. If that particular frame offset is not available, a hard handoff may be required. Frame offset is a network resource and can be used up

HANDOFF INITIATION

A hard handoff occurs when the old connection is broken before a new connection is activated. The performance evaluation of a hard handoff is based on various initiation criteria [1, 3, 13]. It is assumed that the signal is averaged over time, so that rapid fluctuations due to the multipath nature of the radio environment can be eliminated. Numerous studies have been done to determine the shape as well as the length of the averaging window and the older measurements may be unreliable. Figure 1.2 shows a MS moving from one BS (BS1) to another (BS2). The mean signal strength of BS1 decreases as the MS moves away from it. Similarly, the mean signal strength of BS2 increases as the MS approaches it. This figure is used to explain various approaches described in the following subsection.

1.3.1 RELATIVE SIGNAL STRENGTH

This method selects the strongest received BS at all times. The decision is based on a mean measurement of the received signal. In Figure 1.2, the handoff would occur at position A. This method is observed to provoke too many unnecessary handoffs, even when the signal of the current BS is still at an acceptable level.

1.3.2 RELATIVE SIGNAL STRENGTH WITH THRESHOLD

This method allows a MS to hand off only if the current signal is sufficiently weak (less than threshold) and the other is the stronger of the two. The effect of the threshold depends on its relative value as compared to the signal strengths of the two BSs at the point at which they are equal. If the threshold is higher than this value, say T1 in Figure 1.2, this scheme performs exactly like the relative signal strength scheme, so the handoff occurs at position A. If the threshold is lower than this value, say T2 in Figure 1.2, the MS would delay handoff until the current signal level crosses the threshold at position B. In the case of T3, the delay may be so long that the MS drifts too far into the new cell.

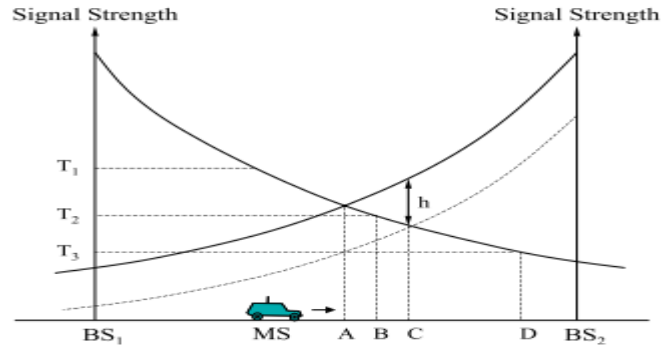

Figure 1.2 Signal strength and hysteresis between two adjacent BSs for potential handoff.

This reduces the quality of the communication link from BS1 and may result in a dropped call. In addition, this results in additional interference to cochannel users. Thus, this scheme may create overlapping cell coverage areas. A threshold is not used alone in actual practice because its effectiveness depends on prior knowledge of the crossover signal strength between the current and candidate BSs.

1.3.3 RELATIVE SIGNAL STRENGTH WITH HYSTERESIS

This scheme allows a user to hand off only if the new BS is sufficiently stronger (by a hysteresis margin, h in Figure 1.2) than the current one. In this case, the handoff would occur at point C. This technique prevents the so-called ping-pong effect, the repeated handoff between two BSs caused by rapid fluctuations in the received signal strengths from both BSs. The first handoff, however, may be unnecessary if the serving BS is sufficiently strong.

1.3.4 RELATIVE SIGNAL STRENGTH WITH HYSTERESIS AND THRESHOLD

This scheme hands a MS over to a new BS only if the current signal level drops below a threshold and the target BS is stronger than the current one by a given hysteresis margin. In Figure 1.2, the handoff would occur at point D if the threshold is T_3

1.3.5 PREDICTION TECHNIQUES

Prediction techniques base the handoff decision on the expected future value of the received signal strength. A technique has been proposed and simulated to indicate better results, in terms of reduction in the number of unnecessary handoffs, than the relative signal strength, both without and with hysteresis, and threshold methods.

CONCEPT OF DELAYING A HANDOFF

In many cases, a two-handoff-level algorithm is used. The purpose of creating two request handoff levels is to provide more opportunity for a successful handoff. A handoff could be delayed if no available cell could take the call. A plot of signal strength with two request handoff levels and a threshold level is shown in Fig.3. The plot of average signal strength is recorded on the channel received

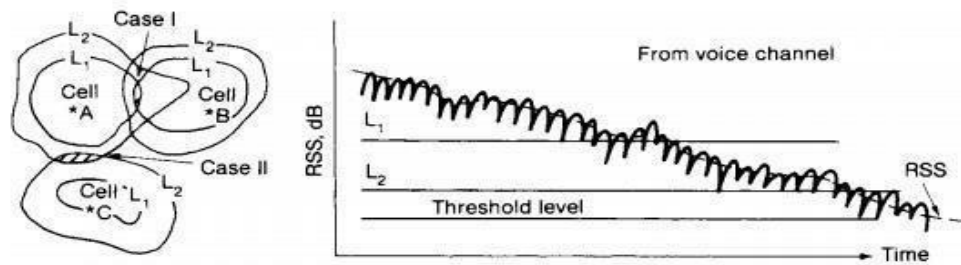

Fig.3. A two level handoff scheme

Signal strength indicator (RSSI), which is installed at each channel receiver at the cell site. When the signal strength drops below the first handoff level, a handoff request is initiated. If for some reason the mobile unit is in a hole (a weak spot in a cell) or a neighboring cell is busy, the handoff will be requested periodically every 5 s. At the first handoff level, the handoff takes place if the new signal is stronger. However, when the second handoff level is reached, the call will be handed off with no condition. The MSO always handles the handoff call first and the originating calls second. If no neighboring calls are available after the second handoff level is reached, the call continues until the signal strength drops below the threshold level; then the call is dropped. In AMPS systems if the supervisory audio tone (SAT) is not sent back to the cell site by the mobile unit within 5 s, the cell site turns off the transmitter.

ADVANTAGES OF DELAYED HANDOFF

1. Consider the following example. The mobile units are moving randomly and the terrain contour is uneven. The received signal strength at the mobile unit fluctuates up and down. If the mobile unit is in a hole for less than 5 s (a driven distance of 140 m for 5 s, assuming a vehicle speed of 100 km/h), the delay (in handoff) can even circumvent the need for a handoff. If the neighboring cells are busy, delayed handoff may take place. In principle, when call traffic is heavy, the switching processor is loaded, and thus a lower number of handoffs would help the processor handle call processing more adequately. Of course, it is very likely that after the second handoff level is reached, the call may be dropped with great probability.
2. The other advantage of having a two-handoff-level algorithm is that it makes the handoff occur at the proper location and eliminates possible interference in the system. Figure 3, case I, shows the area where the first-level handoff occurs between cell A and cell B. If we only use the second-level handoff boundary of cell A, the area of handoff is too close to cell B. Figure 3, case II, also shows where the second-level handoff occurs between cell A and cell C. This is because the first-level handoff cannot be implemented.

POWER DIFFERENCE HANDOFF

A better algorithm is based on the power difference (Δ) of a mobile signal received by two cell sites, home and handoff. Δ can be positive or negative. The handoff occurs depending on a preset value of Δ .

CELLULAR MOBILE COMMUNICATIONS

P_c = the mobile signal measured at the candidate handoff site

P_h – The mobile signal measured at the home site

For example, the following cases can occur.

$P_c > 3$ dB request a handoff

1 dB $< P_c < 3$ dB prepare a handoff

-3 dB $< P_c < 0$ dB monitoring the signal strength

$P_c < -3$ dB no handoff

Those numbers can be changed to fit the switch processor capacity. This algorithm is not based on the received signal strength level, but on a relative (power difference) measurement. Therefore, when this algorithm is used, all the call handoffs for different vehicles can occur at the same general location in spite of different mobile antenna gains or heights.

FORCED HANDOFF

A forced handoff is defined as a handoff that would normally occur but is prevented from happening, or a handoff that should not occur but is forced to happen.

MOBILE-ASSISTED HANDOFF

In a mobile-assisted handoff process, the MS makes measurements and the network makes the decision. In the circuit switched GSM (global system mobile), the BS controller (BSC) is in charge of the radio interface management. This mainly means allocation and release of radio channels and handoff management. The handoff time between handoff decision and execution in such a circuit-switched GSM is approximately 1 second.

SOFT HANDOFF

SOFT HANDOFF (FORWARD LINK)

In this case all traffic channels assigned to the mobile are associated with pilots in the active set and carry the same traffic information with the exception of power control subchannel. When the active set contains more than one pilot, the mobile provides diversity by combining its associated forward traffic channels.

SOFT HANDOFF (REVERSE LINK)

During intercell handoff, the mobile sends the same information to both base stations. Each base station receives the signal from the mobile with appropriate propagation delay. Each base station then transmits the received signal to the vocoder/selector. In other words, two copies of the same frame are sent to the vocoder/selector. The vocoder/selector selects the better frame and discards the other.

SOFTER HANDOFF (REVERSE LINK)

During intersector handoff, the mobile sends the same information to both sectors. The channel card/element at the cell site receives the signals from both sectors. The channel card combines both inputs, and only one frame is sent to the vocoder/selector. It should be noted that extra channel cards are not required to support softer handoff as is the case for soft handoffs. The diversity gain from soft handoffs is more than the

CELLULAR MOBILE COMMUNICATIONS

diversity gain from softer handoffs because signals from distinct cells are less correlated than signals from sectors of the same cell.

10.2.4 BENEFIT OF SOFT HANDOFF

A key benefit of soft handoff is the path diversity on the forward and reverse traffic channels. Diversity gain is obtained because less power is required on the forward and reverse links. This implies that total system interference is reduced. As a result, the average system capacity is improved. Also less transmit power from the mobile results in longer battery life and longer talk time. In a soft handoff, if a mobile receives an up power control bit from one base station and a down control bit from the second base station, the mobile decreases its transmit power. The mobile obeys the power down command since a good communications link must have existed to warrant the command from the second base station.

INTERSYSTEM HANDOFF

Occasionally, a call may be initiated in one cellular system (controlled by one MSO) and enter another system (controlled by another MSO) before terminating. In some instances, intersystem handoff can take place; this means that a call handoff can be transferred from one system to a second system so that the call is continued while the mobile unit enters the second system. The software in the MSO must be modified to apply this situation. Consider the simple diagram shown in Fig.7. The car travels on a highway and the driver originates a call in system A. Then the car leaves cell site A of system A and enters cell site B of system B. Cell sites A and B are controlled by two different MSOs. When the mobile unit signal becomes weak in cell site A, MSO A searches for a candidate cell site in its system and cannot find one. Then MSO A sends

The handoff request to MSO B through a dedicated line between MSO A and MSO B, and MSO B makes a complete handoff during the call conversation. This is just a one-point connection case. There are many ways of implementing intersystem handoffs, depending on the actual circumstances. For instance, if two MSOs are manufactured by different companies, then compatibility must be determined before implementation of intersystem handoff can be considered.

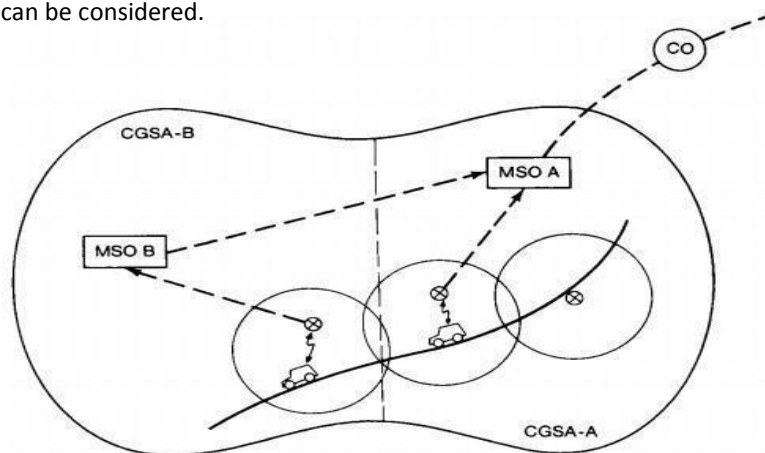

Fig.7. Intersystem handoffs