

# MICROWAVE ENGINEERING

## LECTURE NOTES

### B.TECH (IV YEAR – I SEM) (2018-19)

Prepared by:

**M SREEDHAR REDDY, Asst.Prof. ECE**

**RENJU PANICKER, Asst.Prof. ECE**

Department of Electronics and Communication Engineering



## MALLA REDDY COLLEGE OF ENGINEERING & TECHNOLOGY

**(Autonomous Institution – UGC, Govt. of India)**

Recognized under 2(f) and 12 (B) of UGC ACT 1956

(Affiliated to JNTUH, Hyderabad, Approved by AICTE - Accredited by NBA & NAAC – 'A' Grade - ISO 9001:2015 Certified)

Maisammaguda, Dhulapally (Post Via. Kompally), Secunderabad – 500100, Telangana State, India

---

# MALLA REDDY COLLEGE OF ENGINEERING & TECHNOLOGY

IV Year B. Tech ECE – I Sem

L T/P/D C 5 -/-/ 4

## (R15A0421) MICROWAVE ENGINEERING OBJECTIVES

1. To analyze micro-wave circuits incorporating hollow, dielectric and planar waveguides, transmission lines, filters and other passive components, active devices.
2. To Use S-parameter terminology to describe circuits.
3. To explain how microwave devices and circuits are characterized in terms of their “S” Parameters.
4. To give students an understanding of microwave transmission lines.
5. To Use microwave components such as isolators, Couplers, Circulators, Tees, Gyrotors etc..
6. To give students an understanding of basic microwave devices (both amplifiers and oscillators).
7. To expose the students to the basic methods of microwave measurements.

### UNIT I:

**Waveguides & Resonators:** Introduction, Microwave spectrum and bands, applications of Microwaves, Rectangular Waveguides-Solution of Wave Equation in Rectangular Coordinates, TE/TM mode analysis, Expressions for fields, Cutoff frequencies, filter characteristics, dominant and degenerate modes, sketches of TE and TM mode fields in the cross-section, Mode characteristics - Phase and Group velocities, wavelengths and impedance relations, Rectangular Waveguides – Power Transmission and Power Losses, Impossibility of TEM Modes ,Micro strip Lines-Introduction,Z0 Relations, losses, Q-factor, Cavity resonators-introduction, Rectangular and cylindrical cavities, dominant modes and resonant frequencies, Q-factor and coupling coefficients, Illustrative Problems.

### UNIT II:

**Waveguide Components-I:** Scattering Matrix - Significance, Formulation and properties, Wave guide multiport junctions - E plane and H plane Tees, Magic Tee, 2-hole Directional coupler, S Matrix calculations for E plane and H plane Tees, Magic Tee, Directional coupler, Coupling mechanisms - Probe, Loop, Aperture types, Wave guide discontinuities - Waveguide Windows, tuning screws and posts, Irises, Transitions, Twists, Bends, Corners and matched loads, Illustrative Problems.

**Waveguide Components-II:** Ferrites composition and characteristics, Faraday rotation, Ferrite components - Gyrotator, Isolator, Circulator.

### UNIT III:

**Linear beam Tubes:** Limitations and losses of conventional tubes at microwave frequencies, Classification of Microwave tubes, **O type tubes** - 2 cavity klystrons-structure, Reentrant cavities, velocity modulation process and Applegate diagram, bunching process and small signal theory Expressions for o/p power and efficiency, Reflex Klystrons-structure, Velocity Modulation, Applegate diagram, mathematical theory of bunching, power output, efficiency, oscillating modes and o/p characteristics, Effect of Repeller Voltage on Power o/p, Significance, types and characteristics of slow wave structures, structure of TWT and amplification process (qualitative treatment), Suppression of oscillations, Gain considerations.

---

#### **UNIT IV:**

**Cross-field Tubes:** Introduction, Cross field effects, Magnetrons-different types, cylindrical travelling wave magnetron-Hull cutoff and Hartree conditions, modes of resonance and PI-mode operation, separation of PI-mode, O/P characteristics.

**Microwave Semiconductor Devices:** Introduction to Microwave semiconductor devices, classification, applications, Transfer Electronic Devices, Gunn diode - principles, RWH theory, Characteristics, Basic modes of operation - Gunn oscillation modes, LSA Mode, Introduction to Avalanche Transit time devices (brief treatment only), Illustrative Problems.

#### **UNIT V:**

**Microwave Measurements:** Description of Microwave Bench – Different Blocks and their Features, Precautions; Waveguide Attenuators – Resistive Card, Rotary Vane types; Waveguide Phase Shifters – Dielectric, Rotary Vane types. Microwave Power Measurement – Bolometer Method. Measurement of Attenuation, Frequency, VSWR, Cavity Q. Impedance Measurements.

#### **TEXT BOOKS:**

8. Microwave Devices and Circuits – Samuel Y. Liao, PHI, 3rd Edition, 1994.
9. Microwave and Radar Engineering- M.Kulkarni, Umesh Publications, 1998.

#### **REFERENCES :**

1. Foundations for Microwave Engineering – R.E. Collin, IEEE Press, John Wiley, 2nd Edition, 2002.
10. Microwave Circuits and Passive Devices – M.L. Sisodia and G.S.Raghuvanshi, Wiley Eastern Ltd., New Age International Publishers Ltd., 1995.
11. Microwave Engineering Passive Circuits – Peter A. Rizzi, PHI, 1999.
12. Electronic and Radio Engineering – F.E. Terman, McGraw-Hill, 4th ed., 1955.
13. Elements of Microwave Engineering – R. Chatterjee, Affiliated East-West Press Pvt. Ltd., New Delhi, 1988.

#### **OUTCOMES**

14. Understand the significance of microwaves and microwave transmission lines
  15. Analyze the characteristics of microwave tubes and compare them
  16. Be able to list and explain the various microwave solid state devices
  17. Can set up a microwave bench for measuring microwave parameters
-

# UNIT- I

## MICROWAVE TRANSMISSION LINES-I

### INTRODUCITON

Microwaves are electromagnetic waves with frequencies between 300MHz (0.3GHz) and 300GHz in the electromagnetic spectrum.

Radio waves are electromagnetic waves within the frequencies 30KHz - 300GHz, and include microwaves. Microwaves are at the higher frequency end of the radio wave band and low frequency radio waves are at the lower frequency end. Mobile phones, phone mast antennas (base stations), DECT cordless phones, Wi-Fi, WLAN, WiMAX and Bluetooth have carrier wave frequencies within the microwave band of the electromagnetic spectrum, and are pulsed/modulated. Most Wi-Fi computers in schools use 2.45GHz (carrier wave), the same frequency as microwave ovens. Information about the frequencies can be found in Wi-Fi exposures and guidelines.

It is worth noting that the electromagnetic spectrum is divided into different bands based on frequency. But the biological effects of electromagnetic radiation do not necessarily fit into these artificial divisions.

A waveguide consists of a hollow metallic tube of either rectangular or circular cross section used to guide electromagnetic wave. Rectangular waveguide is most commonly used as waveguide. waveguides are used at frequencies in the microwave range.

At microwave frequencies ( above 1GHz to 100 GHz ) the losses in the two line transmission system will be very high and hence it cannot be used at those frequencies . hence microwave signals are propagated through the waveguides in order to minimize the losses.

### Properties and characteristics of waveguide:

1. The conducting walls of the guide confine the electromagnetic fields and thereby guide the electromagnetic wave through multiple reflections .
2. when the waves travel longitudinally down the guide, the plane waves are reflected from wall to wall .the process results in a component of either electric or magnetic fields in the direction of propagation of the resultant wave.
3. TEM waves cannot propagate through the waveguide since it requires an axial conductor for axial current flow .
4. when the wavelength inside the waveguide differs from that outside the guide, the velocity of wave propagation inside the waveguide must also be different from that through free space.
5. if one end of the waveguide is closed using a shorting plate and allowed a wave to propagate from other end, then there will be complete reflection of the waves

resulting in standing waves.

## APPLICATION OF MAXWELLS EQUATIONS TO THE RECTANGULAR WAVEGUIDE:

Let us consider waves propagating along Oz but with restrictions in the  $x$  and/or  $y$  directions. The wave is now no longer necessarily transverse. The wave equation can

be written as

$$\nabla^2 \vec{H} + k^2 \vec{H} = 0 \quad \text{where } k = \frac{\omega}{c}$$

In the present case this becomes

$$\left( \frac{\partial^2}{\partial x^2} + \frac{\partial^2}{\partial y^2} - k_z^2 + k^2 \right) \vec{H} = 0$$

and similarly for electric field.

There are three kinds of solution possible

TEM	$H_z = E_z = 0,$	i.e. the familiar transverse EM waves
TE	$E_z = 0$	
TM	$H_z = 0$	

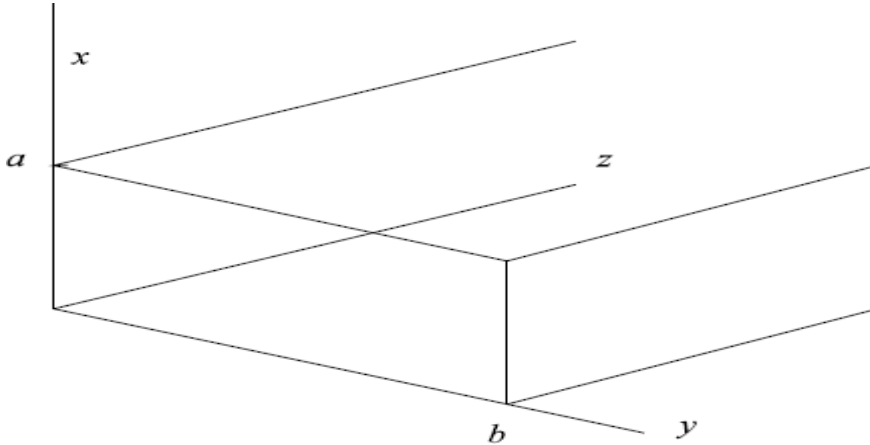
### Boundary conditions:

We assume the guides to be perfect conductors so  $\vec{E} = 0$  inside the guides. Hence, the continuity of  $E_t$  at a boundary implies that  $E_t = 0$  in the wave guide at the boundary.

$E_n$  is not necessarily zero in the wave guide at the boundary as there may be surface charges on the conducting walls (the solution given below implies that there are such charges)

It follows from Maxwell's equation that because  $\nabla \cdot \mathbf{H} = 0$ , is also zero inside the conductor (the time dependence of is  $\exp(-i\omega t)$ ). The continuity of  $H_n$  implies that  $H_n = 0$  at the boundary.

There are currents induced in the guides but for perfect conductors these can be only surface currents. Hence, there is no continuity for  $H_t$ . This is to be contrasted with the boundary condition used for waves reflecting off conducting surfaces with finite conductivity.



The standard geometry for a rectangular wave guide is given fig 1. A wave can be guided by two parallel planes for which case we let the planes at  $x = 0, a$  extend to  $y = \pm 4$ .

**TE Modes:** By definition,  $E_z = 0$  and we start from

$$H_z = H_0 X(x) Y(y) e^{ik_z z}$$

as the wave equation in Cartesian coordinates permits the use of the separation of variables.

**TM Modes:** By definition,  $H_z = 0$  and we start from

$$E_z = E_0 X(x) Y(y) e^{ik_z z}$$

It is customary in wave guides to use the longitudinal field strength as the reference. For the parallel plate wave guide there is no  $y$  dependence so just set  $Y$

=

### TE modes

Using the above form for the solution of the wave equation, the wave equation can be rewritten as

$$\frac{X''}{X} + \frac{Y''}{Y} = k_z^2 - k^2$$

Let  $\frac{X''}{X} = -k_x^2$  and  $\frac{Y''}{Y} = -k_y^2$ ,  $k_x^2 + k_y^2 + k_z^2 = k^2$

the minus signs being chosen so that we get the oscillatory solutions needed to fit the boundary conditions.

Now apply the boundary conditions to determine the restrictions on  $H_z$ . At  $x = 0, a$ :

$$E_y = 0 \text{ and } H_x = 0 \text{ (} E_z \text{ is zero everywhere)}$$

For the following Griffith's writes down all the Maxwell equations specialized to propagation along  $0z$ . I will write just those needed for the specific task and motivate the choice.

We need to relate  $E_y, H_x$  to the reference  $H_z$ . Hence, we use the  $y$  component of ME2 (which has 2  $H$  fields and 1  $E$  field)

$$\frac{\partial H_x}{\partial z} - \frac{\partial H_z}{\partial x} = -i\omega \epsilon_0 E_y$$

The first term is  $ik_z H_x$  which is zero at the boundary.

Consequently,  $\frac{\partial H_z}{\partial x} = 0$  at  $x = 0, a$  and  $X = \cos k_x x$  with

$$k_x = \frac{m\pi}{a}$$

The absence of an arbitrary constant upon integration is justified below. At  $y = 0, b$ :

$$E_x = 0 \text{ and } H_y = 0 \text{ and we now use the } x \text{ component of ME2}$$

$$\frac{\partial H_z}{\partial y} - \frac{\partial H_y}{\partial z} = -i\omega \epsilon_0 E_x$$

As the second term is proportional  $H_y$  we get

The general solution is thus

$$H_x = H_0 \cos(k_x x) \cos(k_y y) e^{ik_z z}$$

$$= H_0 \cos\left(\frac{m\pi x}{a}\right) \cos\left(\frac{n\pi y}{b}\right) e^{ik_z z}$$

However,  $m = n = 0$  is not allowed for the following reason.

When  $m = n = 0$ ,  $H_z$  is constant across the waveguide for any  $xy$  plane. Consider the integral version of Faraday's law for a path that lies in such a plane and encircles the wave guide but in the metal walls.

$$\int \vec{E} \cdot d\vec{l} = -\frac{d}{dt} \int \vec{B} \cdot d\vec{a}$$

As  $E = 0$  in the conducting walls and the time dependence of is given by  $\exp(-i\omega t)$  this equation requires that  $\frac{dB_z}{dt} = 0$ . We need only evaluate the integral over the guide as  $E = 0$  in the walls.

For constant  $B_z$  this gives  $B_z ab = 0$ . So  $B_z = 0$  as is  $H_z$ . However, as we have chosen  $E_z = 0$  this implies a TEM wave which cannot occur inside a hollow waveguide. Adding an arbitrary constant would give a solution like

$$H_x = H_0 \left[ \cos\left(\frac{m\pi x}{a}\right) + \text{Const} \right] \cos\left(\frac{n\pi y}{b}\right) e^{ik_z z}$$

which is not a solution to the wave equation ... try it. It also equivalent to adding a solution with either  $m = 0$  or  $n = 0$  which is a solution with a different

### Cut off frequency

This restriction leads to a minimum value for  $k$ . In order to get propagation  $k_z^2 >$

0. Consequently

$$k^2 > k_x^2 + k_y^2$$

i.e. 
$$\omega^2 > c^2 \pi^2 \left[ \left(\frac{m}{a}\right)^2 + \left(\frac{n}{b}\right)^2 \right]$$

Suppose  $a > b$  then the minimum frequency is  $cB/a$  and for a limited range of  $T$  (dependent on  $a$  and  $b$ ) this solution ( $m = 1, n = 0$ , or TE<sub>10</sub>) is the only one possible.

Away from the boundaries



$$ik_z H_x + k_x H_z^x = -i\omega \epsilon_0 E_y$$

where  $H_z^x$  means that  $\cos k_x x$  has been replaced by  $\sin k_x x$ .

We need another relation between  $E_y$  and either  $H_x$  or  $H_z$ , which must come from the other Maxwell equation (ME1). We have to decide which component of ME1 to use. If we choose the  $z$  component, the equation involves  $E_x$  and  $E_y$ , introducing another unknown field ( $E_x$ ). However, the  $x$  component involves  $E_y$  and  $E_z$ . As  $E_z = 0$ , this gives the required relation.

$$\frac{\partial E_z}{\partial y} - \frac{\partial E_y}{\partial z} = i\mu_0 \omega H_x$$

$$i.e. \quad -ik_z E_y = i\mu_0 \omega H_x, \quad \text{or} \quad k_z E_y = -\mu_0 \omega H_x$$

Substituting in the above gives

$$-\frac{ik_z^2 E_y}{\mu_0 \omega} + i\omega \epsilon_0 E_y = -k_x H_z^x, \quad E_y = \frac{i\mu_0 \omega k_x}{k_x^2 + k_y^2} H_z^x, \quad \text{etc}$$

$$-k_y H_z^y - ik_z H_y = -i\omega \epsilon_0 E_x$$

and the  $y$  component of ME1

$$ik_z E_x = i\mu_0 \omega H_y$$

we get

$$-\frac{ik_z^2 E_x}{\mu_0 \omega} + i\omega \epsilon_0 E_x = k_y H_z^y, \quad E_x = -\frac{i\mu_0 \omega k_y}{k_x^2 + k_y^2} H_z^y$$

## Velocity

The phase velocity  $v_p$  is given by

$$v_p = \frac{\omega}{k_z} = \frac{ck}{k_z} = \frac{ck}{\sqrt{k^2 - k_x^2 - k_y^2}} > c$$

However the group velocity is given by

$$v_g = \frac{\partial\omega}{\partial k_z} = c \frac{\partial k}{\partial k_z} = c \frac{k_z}{k} < c \quad \text{and} \quad v_p v_g = c^2$$

## TM modes

The boundary conditions are easier to apply as it is  $E_z$  itself that is zero at the boundaries.

Consequently, the solution is readily found to be

$$E_z = E_0 \sin(k_x x) \sin(k_y y) e^{ik_z z}$$

Note that the lowest TM mode is due to the fact that  $E_z \neq 0$ . Otherwise, along with  $H_z = 0$ , the solution is a TEM mode which is forbidden. The details are not given here as the TM wave between parallel plates is an assignment problem.

It can be shown that for ohmic losses in the conducting walls the TM modes are more attenuated than the TE modes.

## MAXWELL EQUATIONS

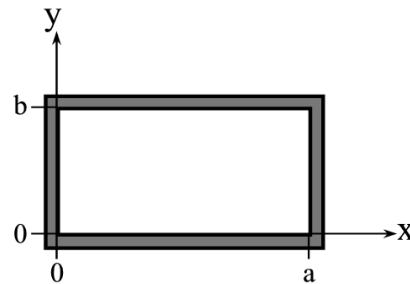
$$\text{ME1} \quad \vec{\nabla} \times \vec{E} = -\mu_0 \frac{\partial \vec{H}}{\partial t} \qquad \text{ME2} \quad \vec{\nabla} \times \vec{H} = \epsilon_0 \frac{\partial \vec{E}}{\partial t}$$

## Rectangular Waveguide:

- Let us consider a rectangular waveguide with interior dimensions are  $a \times b$ ,
- Waveguide can support TE and TM modes.
  - In TE modes, the electric field is transverse to the direction of propagation.
  - In TM modes, the magnetic field that is transverse and an electric field component is in the propagation direction.

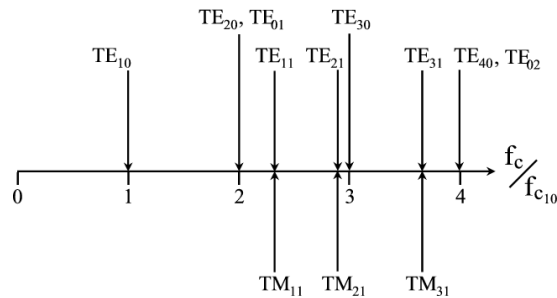
- The order of the mode refers to the field configuration in the guide, and is given by m and n integer subscripts, TE<sub>mn</sub> and TM<sub>mn</sub>.
  - The m subscript corresponds to the number of half-wave variations of the field in the x direction, and
  - The n subscript is the number of half-wave variations in the y direction.
- A particular mode is only supported above its cutoff frequency. The cutoff frequency is given by

Rectangular Waveguide



e

Location of mod



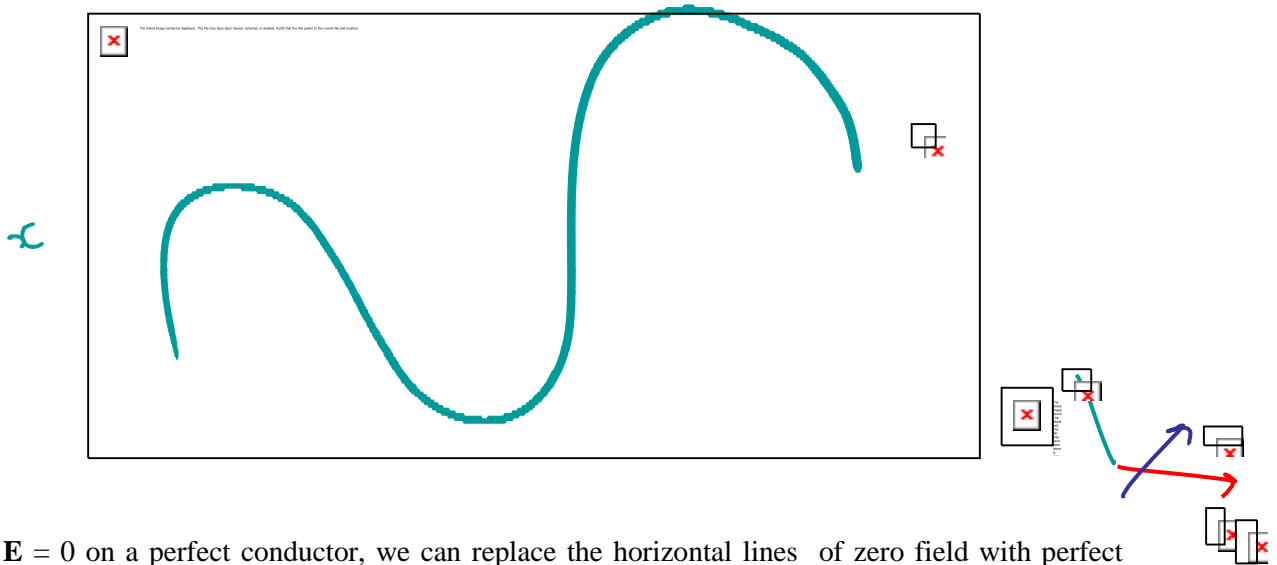
$$f_{c_{mn}} = \frac{1}{2\sqrt{\mu\epsilon}} \sqrt{\left(\frac{m}{a}\right)^2 + \left(\frac{n}{b}\right)^2} = \frac{c}{2\sqrt{\mu_r\epsilon_r}} \sqrt{\left(\frac{m}{a}\right)^2 + \left(\frac{n}{b}\right)^2}$$

$$u = \frac{1}{\sqrt{\mu\epsilon}} = \frac{1}{\sqrt{\mu_o\mu_r\epsilon_o\epsilon_r}} = \frac{1}{\sqrt{\mu_o\epsilon_o}} \frac{1}{\sqrt{\mu_r\epsilon_r}} = \frac{c}{\sqrt{\mu_r\epsilon_r}}$$

We can achieve a qualitative understanding of wave propagation in waveguide by considering the wave to be a superposition of a pair of TEM waves.

Let us consider a TEM wave propagating in the  $z$  direction. Figure shows the wave fronts; bold lines indicating constant phase at the maximum value of the field ( $+E_0$ ), and lighter lines indicating constant phase at the minimum value ( $-E_0$ ).

The waves propagate at a velocity  $u$ , where the  $u$  subscript indicates media unbounded by guide walls. In air,  $u = c$ .



Since we know  $\mathbf{E} = 0$  on a perfect conductor, we can replace the horizontal lines of zero field with perfect conducting walls. Now,  $u_+$  and  $u_-$  are reflected off the walls as they propagate along the guide.

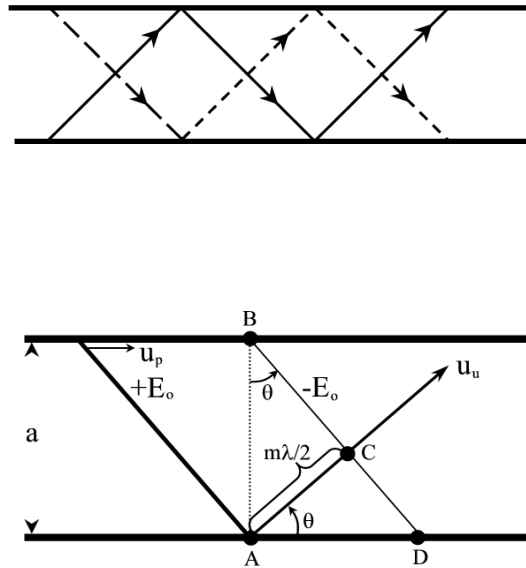
The distance separating adjacent zero-field lines in Figure (b), or separating the conducting walls in Figure (a), is given as the dimension  $a$  in Figure (b).

The distance  $a$  is determined by the angle  $\theta$  and by the distance between wavefront peaks, or the wavelength  $\lambda$ .

For a given wave velocity  $u$ , the frequency is  $f = u/\lambda$ .

If we fix the wall separation at  $a$ , and change the frequency, we must then also change the angle  $\theta$  if we are to maintain a propagating wave. Figure (b) shows wave fronts for the  $u_+$  wave.

The edge of a  $+E_o$  wave front (point A) will line up with the edge of a  $-E_o$  front (point B), and the two fronts must be  $\lambda/2$  apart for the  $m = 1$  mode.



For any value of  $m$ , we can write by simple trigonometry

$$\sin\theta = \frac{m \lambda/2}{a} \quad \longrightarrow \quad \lambda = \frac{2a}{m} \sin\theta = \frac{u}{f}$$

The waveguide can support propagation as long as the wavelength is smaller than a critical value,  $\lambda_c$ , that occurs at  $\theta = 90^\circ$ , or

$$\lambda_c = \frac{2a}{m} = \frac{u}{f_c}$$

Where  $f_c$  is the cutoff frequency for the propagating mode.

We can relate the angle  $\theta$  to the operating frequency and the cutoff frequency by

$$\sin \theta = \frac{\lambda}{\lambda_c} = \frac{f_c}{f}$$

The time  $t_{AC}$  it takes for the wavefront to move from A to C (a distance  $l_{AC}$ ) is

$$t_{AC} = \frac{\text{Distance from A to C}}{\text{Wavefront Velocity}} = \frac{l_{AC}}{u_u} = \frac{m \lambda / 2}{u_u}$$

A constant phase point moves along the wall from A to D.

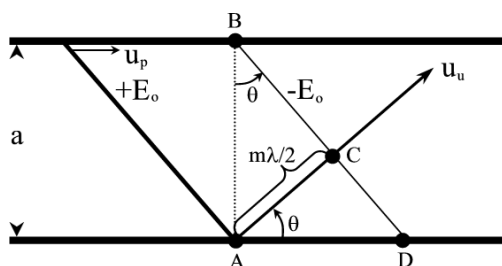
Calling this phase

velocity  $u_p$ , and given the distance  $l_{AD}$  is

$$l_{AD} = \frac{m \lambda / 2}{\cos \theta}$$

Then the time  $t_{AD}$  to travel from A to D is

$$t_{AD} = \frac{l_{AD}}{u_p} = \frac{m \lambda / 2}{\cos \theta u_p}$$



Since the times  $t_{AD}$  and  $t_{AC}$  must be equal, we have

$$u_p = \frac{u_u}{\cos \theta}$$

The Wave velocity is given by

$$u_u = \frac{1}{\sqrt{\mu \epsilon}} = \frac{1}{\sqrt{\mu_o \mu_r \epsilon_o \epsilon_r}} = \frac{1}{\sqrt{\mu_o \epsilon_o}} \frac{1}{\sqrt{\mu_r \epsilon_r}} = \frac{c}{\sqrt{\mu_r \epsilon_r}}$$

The Phase velocity is given by

$$u_p = \frac{u_u}{\cos \theta}$$

$$u_G = u_u \cos \theta$$

The Group velocity is given by

The phase constant is given by

$$\beta = \beta_u \sqrt{1 - \left(\frac{f_c}{f}\right)^2}$$

The guide wavelength is given by

$$\lambda = \frac{\lambda_u}{\sqrt{1 - \left(\frac{f_c}{f}\right)^2}}$$

The ratio of the transverse electric field to the transverse magnetic field for a propagating mode at a particular frequency is the *waveguide impedance*.

For a TE mode, the wave impedance is

$$Z_{mn}^{TE} = \frac{\eta_u}{\sqrt{1 - \left(\frac{f_c}{f}\right)^2}},$$

For a TM mode, the wave impedance is

$$Z_{mn}^{TM} = \eta_u \sqrt{1 - \left(\frac{f_c}{f}\right)^2}.$$



**General Wave Behaviors:**

The wave behavior in a waveguide can be determined by

Mode	Wave Impedance, $Z$	Guide Wavelength, $\lambda_g$
TEM	$\eta = \sqrt{\frac{\mu}{\epsilon}}$	$\lambda = \frac{1}{f\sqrt{\mu\epsilon}}$
TM	$\eta \sqrt{1 - \left(\frac{f_c}{f}\right)^2}$	$\frac{\lambda}{\sqrt{1 - (f_c/f)^2}}$
TE	$\frac{\eta}{\sqrt{1 - (f_c/f)^2}}$	$\frac{\lambda}{\sqrt{1 - (f_c/f)^2}}$

$$H_x^0 = -\frac{1}{h^2} \left( \gamma \frac{\partial H_z^0}{\partial x} - j\omega\epsilon \frac{\partial E_z^0}{\partial y} \right),$$

$$H_y^0 = -\frac{1}{h^2} \left( \gamma \frac{\partial H_z^0}{\partial y} + j\omega\epsilon \frac{\partial E_z^0}{\partial x} \right),$$

$$E_x^0 = -\frac{1}{h^2} \left( \gamma \frac{\partial E_z^0}{\partial x} + j\omega\mu \frac{\partial H_z^0}{\partial y} \right),$$

$$E_y^0 = -\frac{1}{h^2} \left( \gamma \frac{\partial E_z^0}{\partial y} - j\omega\mu \frac{\partial H_z^0}{\partial x} \right),$$

$$H_x^0 = \frac{j\omega\epsilon}{h^2} \frac{\partial E_z^0}{\partial y},$$

$$H_y^0 = -\frac{j\omega\epsilon}{h^2} \frac{\partial E_z^0}{\partial x},$$

$$E_x^0 = -\frac{\gamma}{h^2} \frac{\partial E_z^0}{\partial x},$$

$$E_y^0 = -\frac{\gamma}{h^2} \frac{\partial E_z^0}{\partial y}.$$

$$\nabla^2 E + k^2 E = 0$$

$$\nabla^2 H + k^2 H = 0$$

Then applying on the z-component where  $k^2 = \omega^2 \mu \epsilon_c$

$$\frac{\partial^2 E_z}{\partial x^2} + \frac{\partial^2 E_z}{\partial y^2} + \frac{\partial^2 E_z}{\partial z^2} - k^2 E_z = 0$$

Solving by method of Separation of Variables :

$$E_z(x, y, z) = X(x)Y(y)Z(z)$$

from where we obtain :

$$\frac{X''}{X} + \frac{Y''}{Y} + \frac{Z''}{Z} = -k^2$$

$$\frac{X''}{X} + \frac{Y''}{Y} + \frac{Z''}{Z} = -k^2$$

$$-k_x^2 - k_y^2 + \gamma^2 = -k^2$$

which results in the expressions :

$$X'' + k_x^2 X = 0$$

$$Y'' + k_y^2 Y = 0$$

$$Z'' - \gamma^2 Z = 0$$

From Faraday and Ampere Laws we can find the remaining four components

$$E_x = -\frac{\gamma}{h^2} \frac{\partial E_z}{\partial x} - \frac{j\omega\mu}{h^2} \frac{\partial H_z}{\partial y}$$

Modes of propagation:

From the above equations we can conclude:

- TEM ( $E_z=H_z=0$ ) can't propagate.
- TE ( $E_z=0$ ) transverse electric
  - In TE mode, the electric lines of flux are perpendicular to the axis of the waveguide
- TM ( $H_z=0$ ) transverse magnetic,  $E_z$  exists
  - In TM mode, the magnetic lines of flux are perpendicular to the axis of the waveguide.
- HE hybrid modes in which all components exists.

**TM Mode:**

$$E_z = E_0 \sin\left(\frac{m\pi}{a}x\right) \sin\left(\frac{n\pi}{b}y\right) e^{-j\beta z}$$

$$H_z = 0$$

$$E_x = -\frac{\gamma}{\partial E} \frac{E_0 \cos\left(\frac{m\pi}{a}x\right) \sin\left(\frac{n\pi}{b}y\right) e^{-\gamma z}}{2}$$

- The  $m$  and  $n$  represent the mode of propagation and indicates the number of variations of the field in the  $x$  and  $y$  directions

**TM Cutoff:**

$$\gamma^2 = \sqrt{(k_x^2 + k_y^2) - k^2}$$

$$= \sqrt{\left(\frac{m\pi}{a}\right)^2 + \left(\frac{n\pi}{b}\right)^2 - \omega^2 \mu \epsilon}$$

- The cutoff frequency occurs when  $(n\pi)^2$

$$\text{When } \omega_c^2 \mu \epsilon = \left(\frac{m\pi}{a}\right)^2 + \left(\frac{n\pi}{b}\right)^2 \quad \text{then } \gamma = \alpha + j\beta = 0$$

$$\text{or } f_c = \frac{1}{2\pi} \frac{1}{\sqrt{\mu \epsilon}} \sqrt{\left(\frac{m\pi}{a}\right)^2 + \left(\frac{n\pi}{b}\right)^2}$$

No propagation, everything is attenuated

$$\text{When } \omega^2 \mu \epsilon < \left(\frac{m\pi}{a}\right)^2 + \left(\frac{n\pi}{b}\right)^2 \quad \gamma = \alpha \quad \text{and } \beta = 0$$

Propagation:

When  $\omega^2 \mu \epsilon > \left| \frac{(m\pi)^2}{a^2} + \frac{(n\pi)^2}{b^2} \right|$   $\gamma = j\beta$  and  $\alpha = 0$

Cutoff

- The cutoff frequency is the frequency below which attenuation occurs and above which propagation takes place. (High Pass)

$$f_{c\ mn} = \frac{u'}{2} \sqrt{\left(\frac{m}{a}\right)^2 + \left(\frac{n}{b}\right)^2}$$

The phase constant becomes

$$\beta = \sqrt{\omega^2 \mu \epsilon - \left(\frac{m\pi}{a}\right)^2 - \left(\frac{n\pi}{b}\right)^2} = \beta' \sqrt{1 - \left(\frac{f_c}{f}\right)^2}$$

Phase velocity and impedance

- The phase velocity is defined as

$$u_p = \frac{u'}{\beta} \quad \lambda = \frac{2\pi}{\beta} = \frac{u_p}{f}$$

- intrinsic impedance of the mode is

$$\eta_{TM} = \frac{E_x}{H_y} = - \frac{E_y}{H_x} = \eta' \sqrt{1 - \left(\frac{f_c}{f}\right)^2}$$

Microstrip transmission line is a kind of "high grade" printed circuit construction, consisting of a track of copper or other conductor on an insulating substrate. There is a "backplane" on the other side of the insulating substrate, formed from similar conductor. There is a "hot" conductor which is the track on the top, and a "return" conductor which is the backplane on the bottom. Microstrip is therefore a variant of 2-wire transmission line.

If one solves the electromagnetic equations to find the field distributions, one finds very nearly a completely TEM (transverse electromagnetic) pattern. This means that there are only a few regions in which there is a component of electric or magnetic field in the direction of wave propagation.

The field pattern is commonly referred to as a Quasi TEM pattern. Under some conditions one has to take account of the effects due to longitudinal fields. An example is geometrical dispersion, where different wave frequencies travel at different phase velocities, and the group and phase velocities are different.

The quasi TEM pattern arises because of the interface between the dielectric substrate and the surrounding air. The electric field lines have a discontinuity in direction at the interface. The boundary conditions for electric field are that the normal component (ie the component at right angles to the surface) of the electric field times the dielectric constant is continuous across the boundary; thus in the dielectric which may have dielectric constant 10, the electric field suddenly drops to 1/10 of its value in air. On the other hand, the tangential component (parallel to the interface) of the electric field is continuous across the boundary. In general then we observe a sudden change of direction of electric field lines at the interface, which gives rise to a longitudinal magnetic field component from the second Maxwell's equation,  $\text{curl } \mathbf{E} = -\text{dB}/\text{dt}$ .

Since some of the electric energy is stored in the air and some in the dielectric, the effective dielectric constant for the waves on the transmission line will lie somewhere between that of the air and that of the dielectric. Typically the effective dielectric constant will be 50-85% of the substrate dielectric constant.

## SUBSTRATE MATERIALS:

Important qualities of the dielectric substrate include

- The microwave dielectric constant
- The frequency dependence of this dielectric constant which gives rise to "material dispersion" in which the wave velocity is frequency-dependent
- The surface finish and flatness
- The dielectric loss tangent, or imaginary part of the dielectric constant, which sets the dielectric loss

- The cost
- The thermal expansion and conductivity
- The dimensional stability with time
- The surface adhesion properties for the conductor coatings
- The manufacturability (ease of cutting, shaping, and drilling)
- The porosity (for high vacuum applications we don't want a substrate which continually "out gasses" when pumped)

Types of substrate include plastics, sintered ceramics, glasses, and single crystal substrates (single crystals may have anisotropic dielectric constants; "anisotropic" means they are different along the different crystal directions with respect to the crystalline axes.)

#### Common substrate materials

- Plastics are cheap, easily manufacturability, have good surface adhesion, but have poor microwave dielectric properties when compared with other choices. They have poor dimensional stability, large thermal expansion coefficients, and poor thermal conductivity.
  - Dielectric constant: 2.2 (fast substrate) or 10.4 (slow substrate)
  - Loss tangent 1/1000 (fast substrate) 3/1000 (slow substrate)
  - Surface roughness about 6 microns (electroplated)
  - Low thermal conductivity, 3/1000 watts per cm sq per degree
- Ceramics are rigid and hard; they are difficult to shape, cut, and drill; they come in various purity grades and prices each having domains of application; they have low microwave loss and are reasonably non- dispersive; they have excellent thermal properties, including good dimensional stability and high thermal conductivity; they also have very high dielectric strength. They cost more than plastics. In principle the size is not limited.
  - Dielectric constant 8-10 (depending on purity) so slow substrate
  - Loss tangent 1/10,000 to 1/1,000 depending on purity
  - Surface roughness at best 1/20 micron



- High thermal conductivity, 0.3 watts per sq cm per degree K
- Single crystal sapphire is used for demanding applications; it is very hard, needs orientation for the desired dielectric properties which are anisotropic;

is very expensive, can only be made in small sheets; has high dielectric constant so is used for very compact circuits at high frequencies; has low dielectric loss; has excellent thermal properties and surface polish.

- Dielectric constant 9.4 to 11.6 depending on crystal orientation (slow substrate)
- Loss tangent 5/100,000
- Surface roughness 1/100 micron
- High thermal conductivity 0.4 watts per sq cm per degree K
- Single crystal Gallium Arsenide (GaAs) and Silicon (Si) are both used for monolithic microwave integrated circuits (MMICs).
  - Dealing with GaAs first we have.....
    - Dielectric constant 13 (slow substrate)
    - Loss tangent 6/10,000 (high resistivity GaAs)
    - Surface roughness 1/40 micron
    - Thermal conductivity 0.3 watts per sq cm per degree K (high)

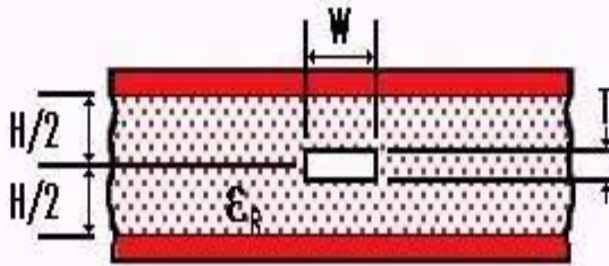
GaAs is expensive and piezoelectric; acoustic modes can propagate in the substrate and can couple to the electromagnetic waves on the conductors.

The dielectric strength of ceramics and of single crystals far exceeds the strength of plastics, and so the power handling abilities are correspondingly higher, and the breakdown of high Q filter structures correspondingly less of a problem.

It is also a good idea to have a high dielectric constant substrate and a slow wave propagation velocity; this reduces the radiation loss from the circuits. However at the higher frequencies the circuits get impossible small, which restricts the power handling capability.

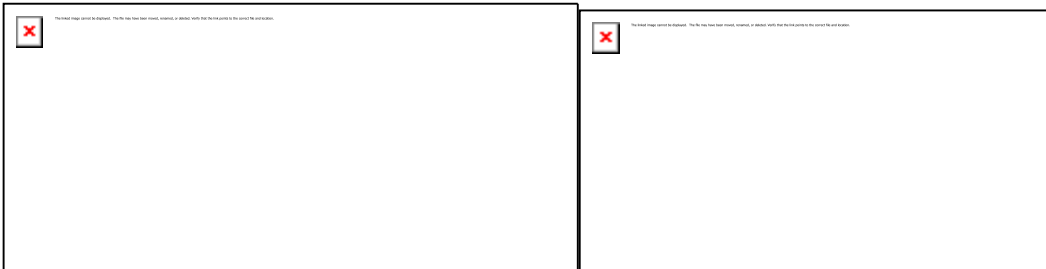
Stripline is a conductor sandwiched by dielectric between a pair of ground planes, much like a coax cable would look after you ran it over with your small-manhood indicating SUV (let's not go there...) In practice, stripline is usually made by etching circuitry on a substrate that has a ground plane on the opposite face, then adding a second substrate (which is metalized on only one surface) on top to achieve the second ground plane. Stripline is most often a "soft-board" technology, but using low-temperature co-fired ceramics (LTCC), ceramic stripline circuits are also possible.

## Stripline Cross-section



Transmission lines on either of the interior metal layers behave very nearly like "classic" stripline, the slight asymmetry is not a problem. Excellent "broadside" couplers can be made by running transmission lines parallel to each other on the two surfaces.

Other variants of the stripline are offset strip line and suspended air stripline (SAS).



For stripline and offset stripline, because all of the fields are constrained to the same dielectric, the effective dielectric constant is equal to the relative dielectric constant of the chosen dielectric material. For suspended stripline, you will have to calculate the effective dielectric constant, but if it is "mostly air", the effective dielectric constant will be close to 1.

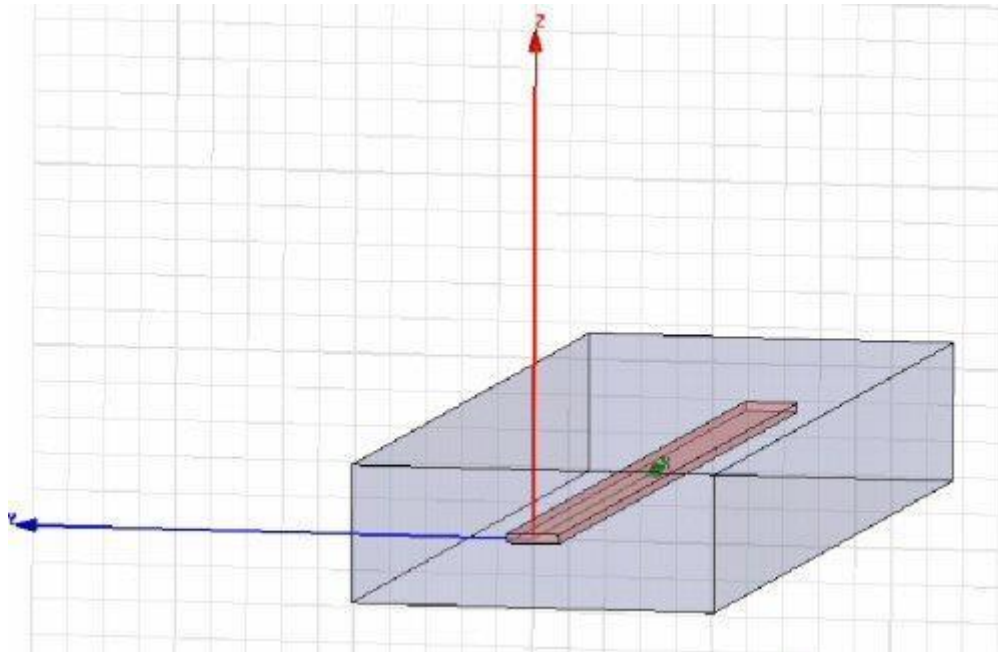
Advantages and disadvantages of stripline:

Stripline is a TEM (transverse electromagnetic) transmission line media, like coax. This means that it is non-dispersive, and has no cutoff frequency. Whatever circuits you can make on microstrip (which is quasi-TEM), you can do better using stripline, unless you run into fabrication or size constraints. Stripline filters and couplers always offer better bandwidth than their counterparts in microstrip.

Another advantage of stripline is that fantastic isolation between adjacent traces can be achieved (as opposed to microstrip). The best isolation results when a picket-fence of vias surrounds each transmission line, spaced at less than  $1/4$  wavelength. Stripline can be used to route RF signals across each other quite easily when offset stripline is used.

Disadvantages of stripline are two: first, it is much harder (and more expensive) to fabricate than microstrip. Lumped-element and active components either have to be buried between the ground planes (generally a tricky proposition), or transitions to microstrip must be employed as needed to get the components onto the top of the board.

The second disadvantage of stripline is that because of the second ground plane, the strip widths are much narrower for a given impedance (such as 50 ohms) and board thickness than for microstrip. A common reaction to problems with microstrip circuits is to attempt to convert them to stripline. Chances are you'll end up with a board thickness that is four times that of your microstrip board to get equivalent transmission line loss. That means you'll need forty mils thick strip line to replace ten mil thick micro strip! This is one of the reasons that soft-board manufacturers offer so many thicknesses.



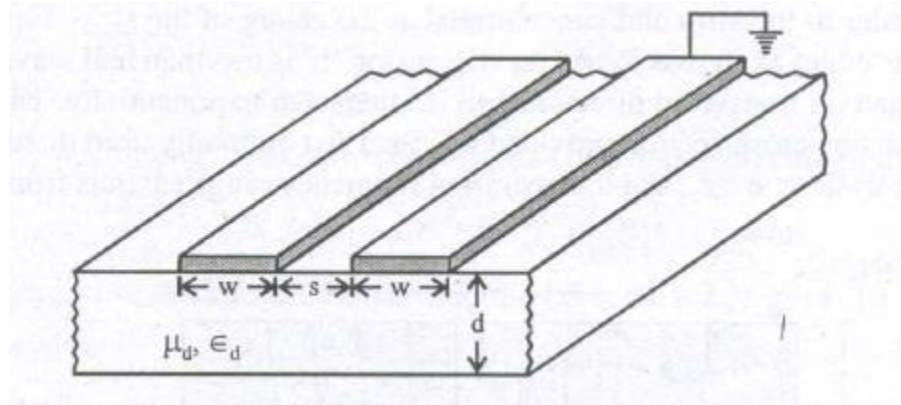
### Stripline equations

A simplified equation for characteristic impedance of stripline is given as:

$$Z_0 = \frac{60}{\sqrt{\epsilon_r}} \ln \left[ \frac{4H}{0.67\pi W \left( 0.8 + \frac{t}{D} \right)} \right]$$

### COPLANAR STRIP LINES

A coplanar strip line consisting of two strip conductors each of width separated by a distance "s", mounted on a single dielectric substrate, with one conducting strip grounded. Since both the strips are on one side of the substrate unlike the parallel strip lines, connection of shunt elements is very easy. This is an added advantage in the manufacture of microwave integrated circuits (MICs). Because of this, reliability increases.



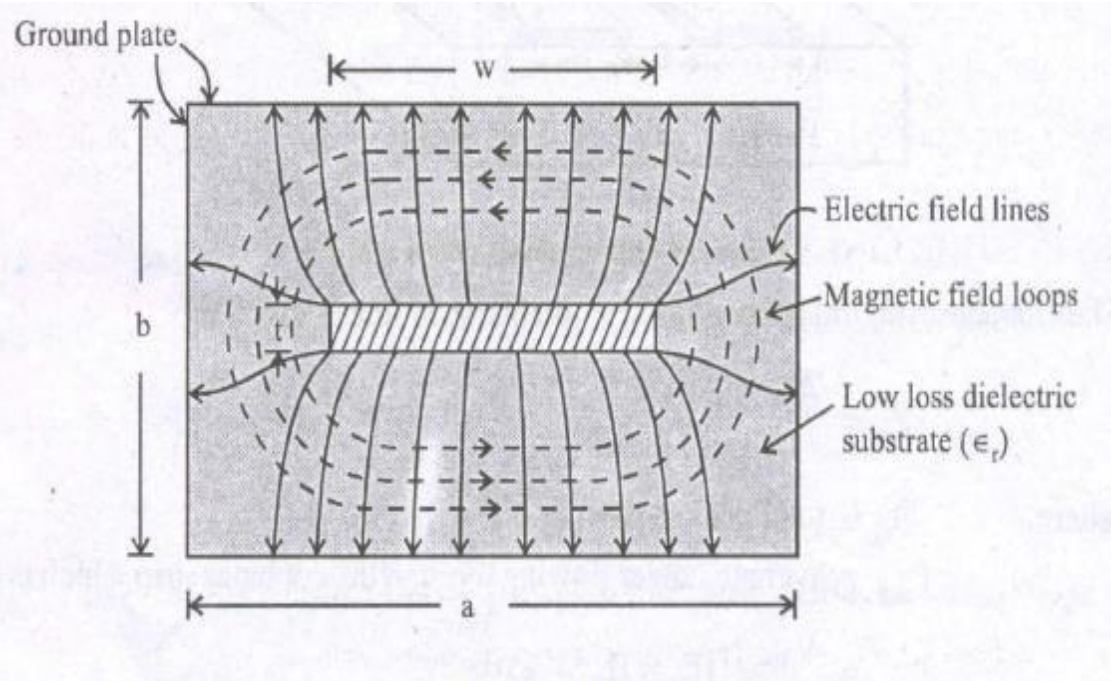
The characteristic impedance of the coplanar strip line is given by

$$Z_0 = \frac{2P_{avg}}{I_0^2}$$

P = average power flowing through the coplanar strip

## SHIELDED STRIP LINES

The configuration of strip line consisting of a thin conducting strip of width "w" much greater than its thickness "t". This strip line is placed at the centre surrounded by a low-loss dielectric substrate of thickness "b", between two ground plates as shown. The mode of propagation is TEM (transverse electro-magnetic) wave where the electric field lines are perpendicular to the strip and concentrated at the centre of the strip. Fringing field lines also exist at the edges. When the dimension 'b' is less than half wavelength, the field cannot propagate in transverse direction and is attenuated exponentially. The energy will be confined to the line cross-section provided  $a > 5b$ . The commonly used dielectrics are teflon, polyolefine, polystyrene etc., and the operating frequency range extends from 100 MHz to 30 GHz.



The characteristic impedance for zero strip thickness is given by

$$Z_o = \frac{30}{\sqrt{\epsilon_R}} \ln \left[ \frac{2(1+\sqrt{k})}{(1-\sqrt{k})} \right] \Omega \text{ for } \frac{w}{b} \leq 0.5 \quad \dots (6.45)$$

$$Z_o = \frac{30\pi^2}{\sqrt{\epsilon_r} \ln \left[ \frac{2(1+\sqrt{k'})}{(1-\sqrt{k'})} \right]} \Omega \text{ for } \frac{w}{b} > 0.5 \quad \dots (6.46)$$

Where  $k = \operatorname{sech} \left( \frac{\pi w}{2b} \right) \quad \dots (6.47)$

and  $k' = \sqrt{1-k^2} = \tanh \left( \frac{\pi w}{2b} \right) \quad \dots (6.48)$

For non-zero strip thickness  $\left( \frac{w}{b} \gg 0.35 \right)$ , the characteristic impedance is given by

$$Z_o = \frac{94.15}{\sqrt{\epsilon_r}} \left[ \frac{wK}{b} + \frac{C_f}{8.854 \epsilon_r} \right]^{-1} \Omega \quad \dots (6.49)$$

Where  $K = \frac{1}{1 - \frac{t}{b}}$   
 $t =$  thickness of the strip  
 $C_f =$  fringing capacitance in pF/m due to fringing electric field at the edges.  
 $C_f = \frac{8.854 \epsilon_r}{\pi} [2K \ln(K+1) - (K-1) \ln(K^2-1)] \text{pF/m} \quad \dots (6.50)$

In practice MICs use thickness 't' of the order of 1.5 to 3 mils [1 mil =  $10^{-3}$  inch]. Since the mode of propagation is TEM, the wavelength in the line is  $\lambda_o / \sqrt{\epsilon_r}$  where  $\lambda_o$  is the free-space wavelength.

### LOSSES IN STRIP LINES:

For low-loss dielectric substrate, the attenuation factor in the strip line arises from conductor losses and is given by

$$\alpha_c = \frac{R_s}{Z_o b} \frac{(\pi w/b) + \ln(4b/\pi t)}{\ln 2 + (\pi W/2b)} \text{ nepers/unit length}$$

where  $R_s = \sqrt{\pi f \mu / \sigma}$



The attenuation constant of a microstrip line depends on frequency of operation, electrical properties of substrate and the conductors and the geometry of mounting of strip on the dielectric.

When the dielectric substrate of dielectric constant is purely non-magnetic then three types of losses occur in microstrip lines . they are

### 1. Dielectric losses in substrate

#### 1. Ohmic losses in strip conductor and ground plane

#### 1. Radiation loss

Dielectric losses in substrate:

All dielectric materials possess some conductivity but it will be small , but when it is not negligible, then the displacement current density leads the conduction current density by 90 degrees, introducing loss tangent for a lossy dielectric .

#### 1. Ohmic losses in strip conductor and ground plane

In a microstrip line the major contribution to losses at micro frequencies is from finite conductivity of microstrip conductor placed on a low loss dielectric substrate. Due to current flowing through the strip, there will be ohmic losses and hence attenuation of the microwave signal takes place. The current distribution in the transverse plane is fairly uniform with minimum value at the central axis and shooting up to maximum values at the edge of the strip.

#### 2. Radiation losses:

At microwave frequencies , the microstrip line acts as an antenna radiating a small amount of power resulting in radiation losses. This loss depends on the thickness of the substrate, the characteristic impedance Z, effective dielectric constant and the frequency of operation.

For low-loss dielectric substrate, the attenuation factor in the strip line arises from conductor losses and is given by

$$\alpha_c = \frac{R_s}{Z_0 b} \frac{(\pi w/b) + \ln(4b/\pi t)}{\ln 2 + (\pi W/2b)} \text{ nepers/unit length}$$

where  $R_s = \sqrt{\pi f \mu / \sigma}$

## **Advantages and disadvantages of Planar Transmission Lines over Co- axial Lines:**

### **Advantages:-**

The advantages of planar transmission lines are

- (a) very small size and hence low weight
- (b) can be easily mounted on a metallic body including substrate.
- (c) increased reliability
- (d) cost is reduced due to small size
- (e) series and shunt maintaining of components is possible
- (f) the characteristic impedance  $Z_0$  is easily controlled by defining the dimensions of the line in a single plane
- (g) by changing the dimensions of the line in one plane only, it is possible to achieve accurate passive circuit design

### **Disadvantages:-**

The disadvantages of planar transmission lines are

- (a) low power handling capability due to small size
- (b) The microstrip, slot and coplanar lines tend to radiate power resulting in radiation losses
- (c) low Q-factor

## UNIT- II

# MICROWAVE WAVEGUIDE COMPONENTS AND APPLICATIONS

### INTRODUCITON

#### WAVE GUIDE CORNERS , BENDS AND TWISTS:

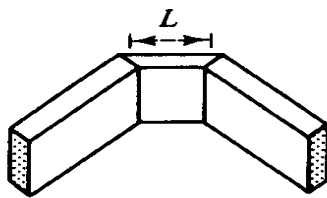
The waveguide corner, bend, and twist are shown in figure below, these waveguide components are normally used to change the direction of the guide through an arbitrary angle.

In order to minimize reflections from the discontinuities, it is desirable to have the mean length  $L$  between continuities equal to an odd number of quarter wave lengths. That is,

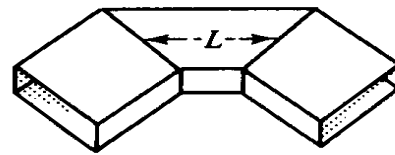
$$L = (2n + 1) \frac{\lambda_g}{4}$$

where  $n = 0, 1, 2, 3, \dots$ , and  $\lambda_g$  is the wavelength in the waveguide. If the mean length  $L$  is an odd number of quarter wavelengths, the reflected waves from both ends of the waveguide section are completely canceled. For the waveguide bend, the minimum radius of curvature for a small reflection is given by Southworth as

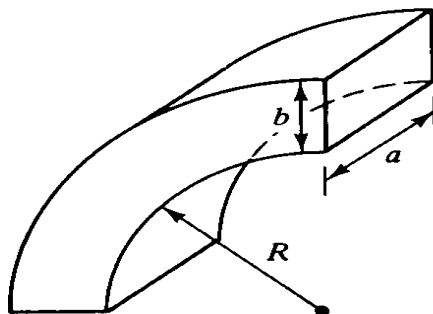
$$R = 1.5b \quad \text{for an } E \text{ bend} \quad R = 1.5a \quad \text{for an } H \text{ bend}$$



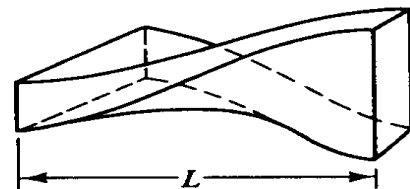
(a)



(b)



(c)



(d)

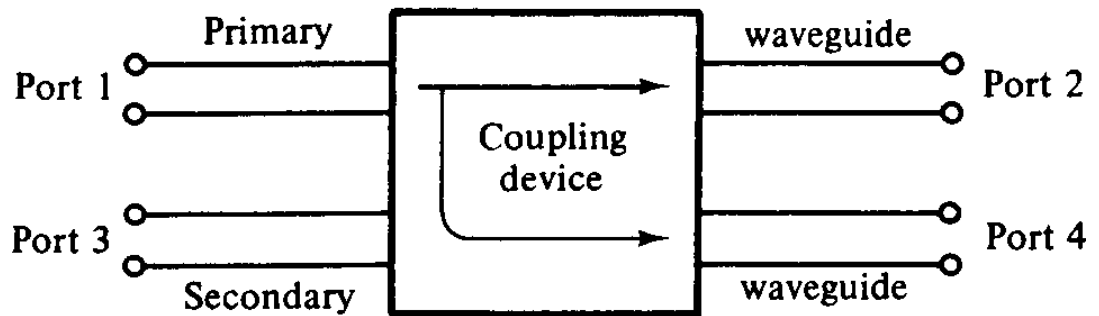
Waveguide corner, bend, and twist. (a) *E*-plane corner. (b) *H*-plane corner. (c) Bend. (d) Continuous twist.

## DIRECTIONAL COUPLERS:

A directional coupler is a four-port waveguide junction as shown below. It consists of a primary waveguide 1-2 and a secondary waveguide 3-4. When all ports are terminated in their characteristic impedances, there is free transmission of the waves without reflection, between port 1 and port 2, and there is no transmission of power between port 1 and port 3 or between port 2 and port 4 because no coupling exists between these two pairs of ports. The degree of coupling between port 1 and port 4 and between port 2 and port 3 depends on the structure of the coupler.

The characteristics of a directional coupler can be expressed in terms of its Coupling factor and its directivity.

Assuming that the wave is propagating from port 1 to port 2 in the primary line, the coupling factor and the directivity are defined,



Directional coupler.

where  $P_1$  = power input to port 1  
 $P_3$  = power output from port 3  
 $P_4$  = power output from port 4

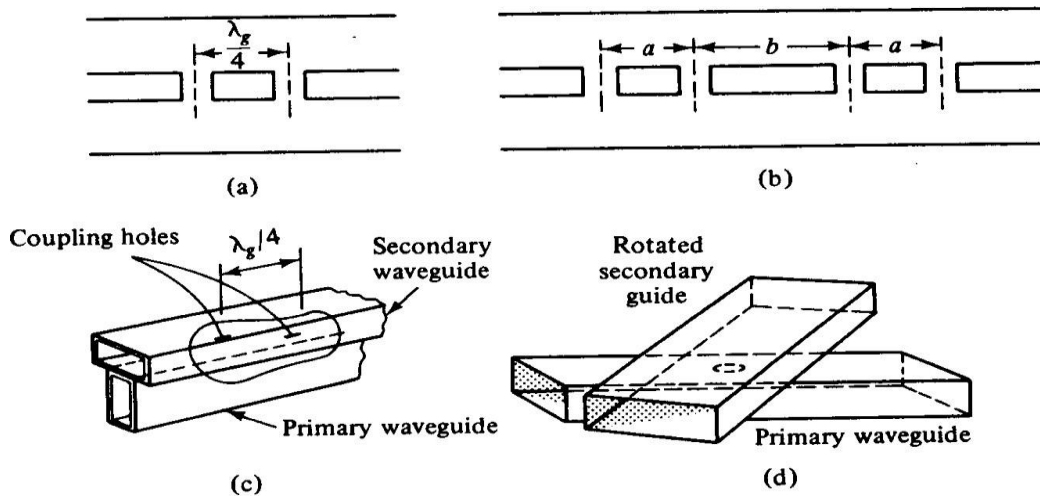
$$\text{Coupling factor (dB)} = 10 \log_{10} \frac{P_1}{P_4}$$

$$\text{Directivity (dB)} = 10 \log_{10} \frac{P_4}{P_3}$$

It should be noted that port 2, port 3, and port 4 are terminated in their characteristic impedances. The coupling factor is a measure of the ratio of power levels in the primary and secondary lines. Hence if the coupling factor is known, a fraction of power measured at port 4 may be used to determine the power input at port 1.

This significance is desirable for microwave power measurements because no disturbance, which may be caused by the power measurements, occurs in the primary line. The directivity is a measure of how well the forward traveling wave in the primary waveguide couples only to a specific port of the secondary waveguide. An ideal directional coupler should have infinite directivity. In other words, the power at port 3 must be zero because port 2 and port 4 are perfectly matched. Actually well-designed directional couplers have a directivity of only 30 to 35 dB.

Several types of directional couplers exist, such as a two-hole directional coupler, four-hole directional coupler, reverse-coupling directional coupler, and Bethe-hole directional coupler. The very commonly used two-hole directional coupler is described here.



**Figure 4-5-2** Different directional couplers. (a) Two-hole directional coupler. (b) Four-hole directional coupler. (c) Schwinger coupler. (d) Bethe-hole directional coupler.

### TWO HOLE DIRECTIONAL COUPLERS:

A two hole directional coupler with traveling wave propagating in it is illustrated. The spacing between the centers of two holes is

$$L = (2n + 1) \frac{\lambda_g}{4}$$

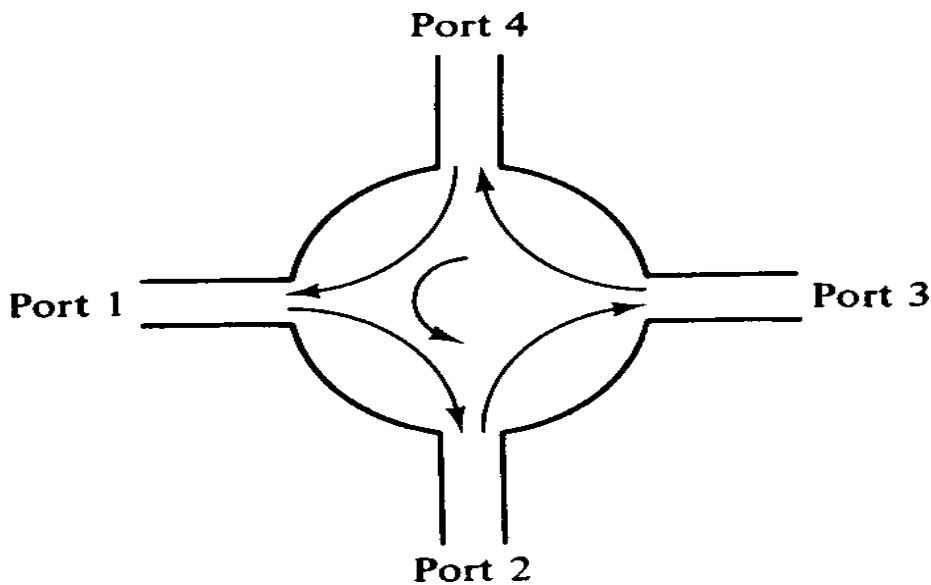
A fraction of the wave energy entered into port 1 passes through the holes and is radiated into the secondary guide as the holes act as slot antennas. The forward waves in the secondary guide are in same phase, regardless of the hole space and are added at port 4. The backward waves in the secondary guide are out of phase and are cancelled in port 3.

## **CIRCUALTORS AND ISOLATORS:**

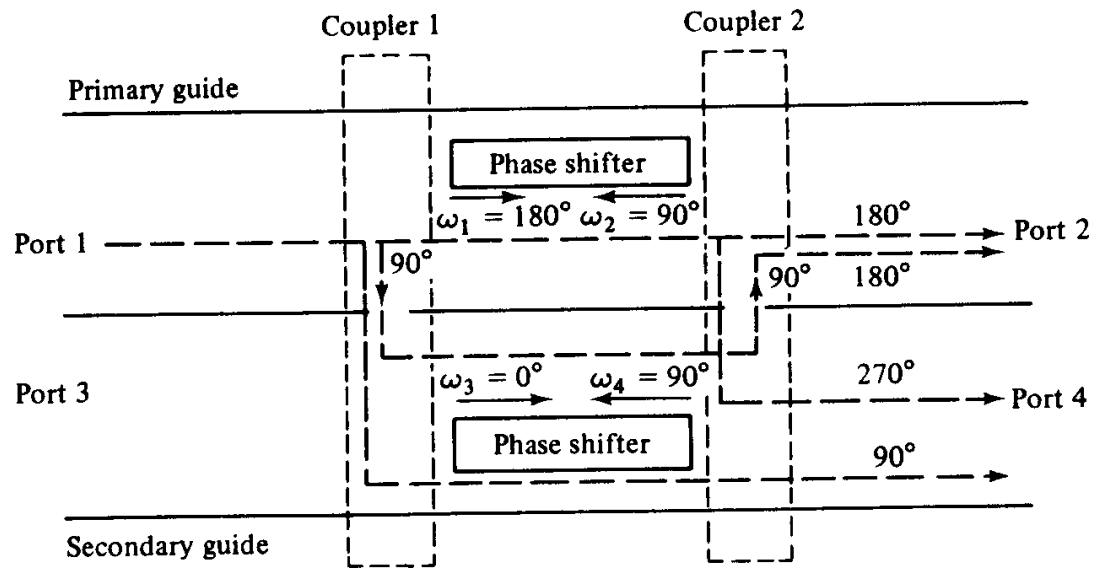
Both microwave circulators and isolators are non reciprocal transmission devices that use the property of Faraday rotation in the ferrite material. A non reciprocal phase shifter consists of thin slab of ferrite placed in a rectangular waveguide at a point where the dc magnetic field of the incident wave mode is circularly polarized. When a piece of ferrite is affected by a dc magnetic field the ferrite exhibits Faraday rotation. It does so because the ferrite is nonlinear material and its permeability is an asymmetric tensor.

## **MICROWAVE CIRCULATORS:**

A *microwave circulator* is a multiport waveguide junction in which the wave can flow only from the  $n$ th port to the  $(n + 1)$ th port in one direction. Although there is no restriction on the number of ports, the four-port microwave circulator is the most common. One type of four-port microwave circulator is a combination of two 3-dB side hole directional couplers and a rectangular waveguide with two non reciprocal phase shifters.



**The symbol of a circulator.**



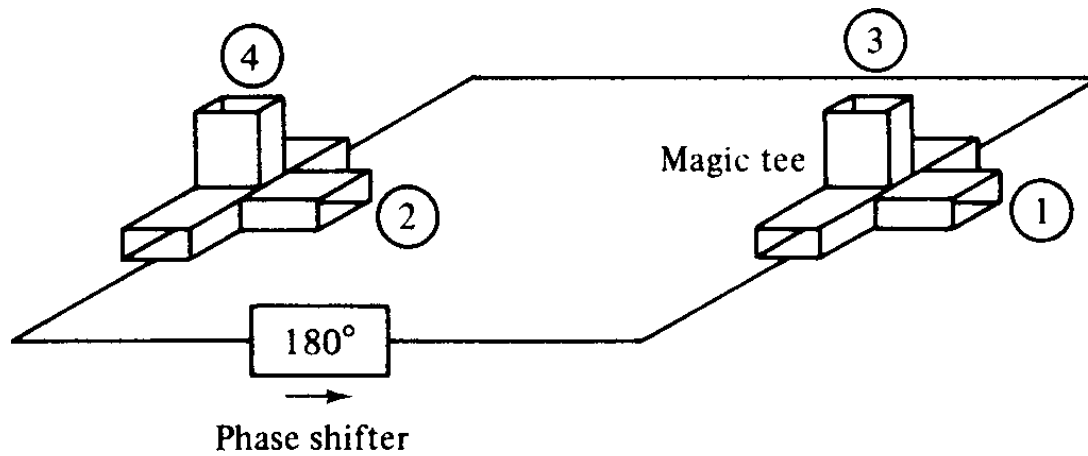
**Schematic diagram of four-port circulator.**

The operating principle of a typical microwave circulator can be analyzed with the aid of Fig shown above .Each of the two 3-dB couplers in the circulator introduces a phase shift of 90°, and each of the two phase shifters produces a certain amount of phase change in a certain direction as indicated. When a wave is incident to port 1,the wave is split into two components by coupler I. The wave in the primary guide arrives at port 2 with a relative phase' change of 180°. The second wave propagates through the two couplers and the secondary guide and arrives at port 2 with a relative phase shift of 180°. Since the two waves reaching port 2 are in phase, the power transmission is obtained from port 1 to port 2. However, the wave propagates through the primary guide, phase shifter, and coupler 2 and arrives at port 4 with a phase change of 270°. The wave travels through coupler 1 and the secondary guide, and it arrives at port 4 with a phase shift of 90°. Since the two waves reaching port 4 are out of phase by 180°, the power transmission from port 1 to port 4 is zero. In general, the differential propagation constants in the two directions of propagation in a waveguide containing ferrite phase shifters should be

$$\omega_1 - \omega_3 = (2m + 1)\pi \quad \text{rad/s}$$

$$\omega_2 - \omega_4 = 2n\pi \quad \text{rad/s}$$

where  $m$  and  $n$  are any integers, including zeros. A similar analysis shows that a wave incident to port 2 emerges at port 3 and so on. As a result, the sequence of power flow is designated as  $1 \sim 2 \sim 3 \sim 4 \sim 1$ . Many types of microwave circulators are in use today. However, their principles of operation remain the same. .A four-port circulator is constructed by the use of two magic tees and a phase shifter. The phase shifter produces a phase shift of 180°.



## A four-port circulator.

A perfectly matched, lossless, and nonreciprocal four-port circulator has an S matrix of the form

$$S = \begin{bmatrix} 0 & S_{12} & S_{13} & S_{14} \\ S_{21} & 0 & S_{23} & S_{24} \\ S_{31} & S_{32} & 0 & S_{34} \\ S_{41} & S_{42} & S_{43} & 0 \end{bmatrix}$$

Using the properties of S parameters the S-matrix is

$$S = \begin{bmatrix} 0 & 0 & 0 & 1 \\ 1 & 0 & 0 & 0 \\ 0 & 1 & 0 & 0 \\ 0 & 0 & 1 & 0 \end{bmatrix}$$

### MICROWAVE ISOLATORS:

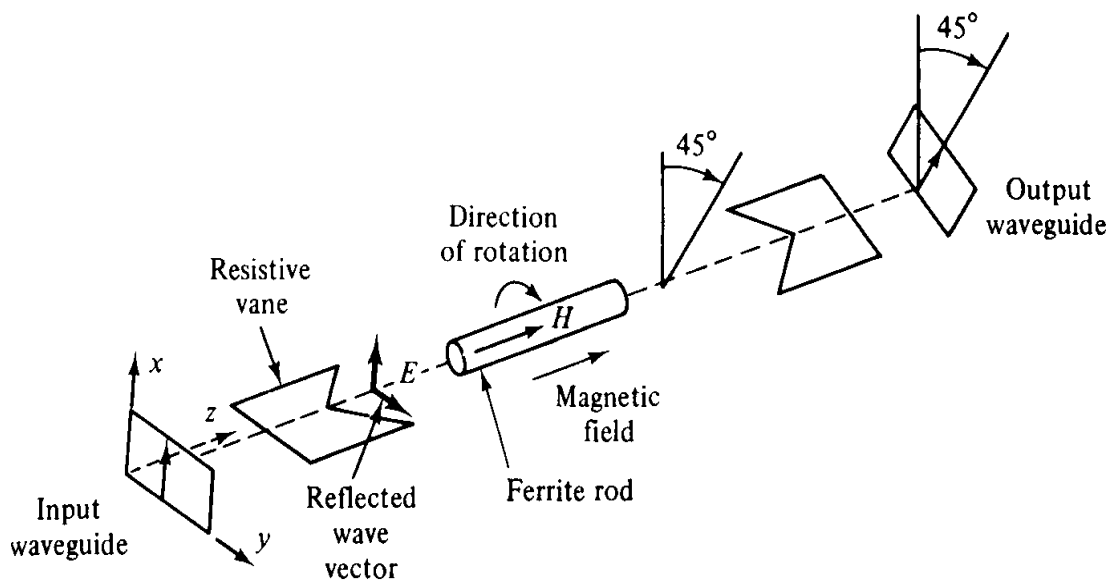
An *isolator* is a nonreciprocal transmission device that is used to isolate one component from reflections of other components in the transmission line. An ideal isolator completely absorbs the power for propagation in one direction and provides lossless transmission in the opposite direction. Thus the isolator is usually called *uniline*.



Isolators are generally used to improve the frequency stability of microwave generators, such as klystrons and magnetrons, in which the reflection from the load affects the generating frequency. In such cases, the isolator placed between the generator and load prevents the reflected power from the unmatched load from returning to the generator. As a result, the isolator maintains the frequency stability of the generator.

Isolators can be constructed in many ways. They can be made by terminating ports 3 and 4 of a four-port circulator with matched loads. On the other hand, isolators can be made by inserting a ferrite rod along the axis of a rectangular waveguide as shown below.

The isolator here is a Faraday-rotation isolator. Its operating principle can be explained as follows . The input resistive card is in the  $y$ - $z$  plane, and the output resistive card is displaced  $45^\circ$  with respect to the input card. The dc magnetic field, which is applied longitudinally to the ferrite rod, rotates the wave plane of polarization by  $45^\circ$ . The degrees of rotation depend on the length and diameter of the rod and on the applied dc magnetic field. An input TE<sub>10</sub> dominant mode is incident to the left end of the isolator. Since the TE<sub>10</sub> mode wave is perpendicular to the input resistive card, the wave passes through the ferrite rod without attenuation. The wave in the ferrite rod section is rotated clockwise by  $45^\circ$  and is normal to the output resistive card. As a result of rotation, the wave arrives at the output.



end without attenuation at all. On the contrary, a reflected wave from the output end is similarly rotated clockwise  $45^\circ$  by the ferrite rod. However, since the reflected wave is parallel to the input resistive card, the wave is thereby absorbed by the input card. The typical performance of these isolators is about 1-dB insertion loss in forward transmission and about 20- to 30-dB isolation in reverse attenuation.

### **WAVE GUIDE TEE JUNCTIONS:**

A waveguide Tee is formed when three waveguides are interconnected in the form of English alphabet T and thus waveguide tee is 3-port junction. The waveguide tees are used to connect a branch or section of waveguide in series or parallel with the main waveguide transmission line either for splitting or combining power in a waveguide system.

There are basically 2 types of tees namely

1.H- plane Tee junction

2.E-plane Tee junction

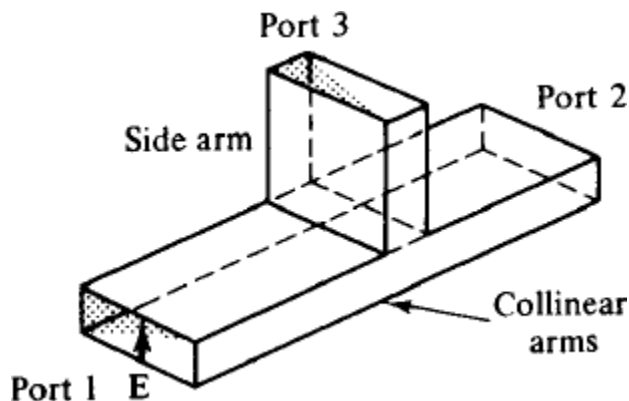
A combination of these two tee junctions is called a hybrid tee or “ Magic Tee”.

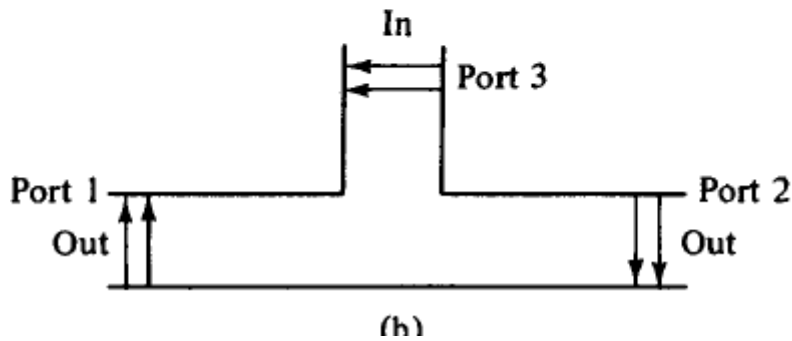
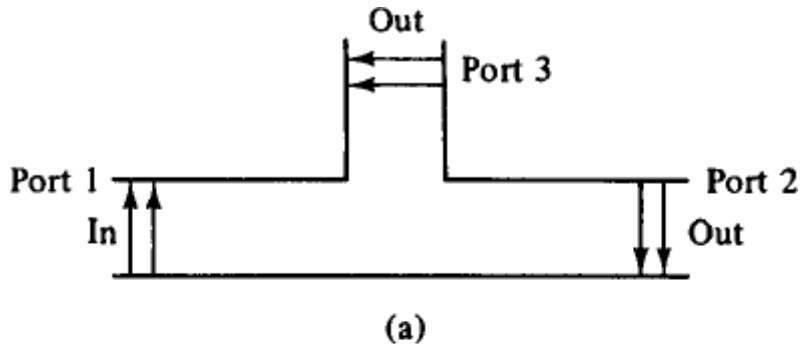
### **E-plane Tee(series tee):**

An E-plane tee is a waveguide tee in which the axis of its side arm is parallel to the E field of the main guide. If the collinear arms are symmetric about the side arm.

If the E-plane tee is perfectly matched with the aid of screw tuners at the junction, the diagonal components of the scattering matrix are zero because there will be no reflection.

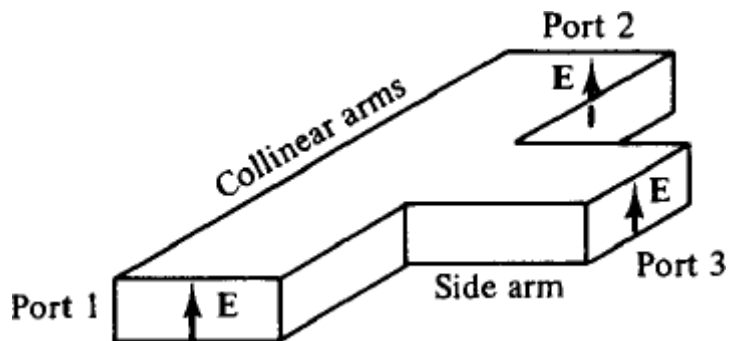
When the waves are fed into side arm, the waves appearing at port 1 and port 2 of the collinear arm will be in opposite phase and in same magnitude.





### H-plane tee: (shunt tee)

An H-plane tee is a waveguide tee in which the axis of its side arm is shunting the E field or parallel to the H-field of the main guide.

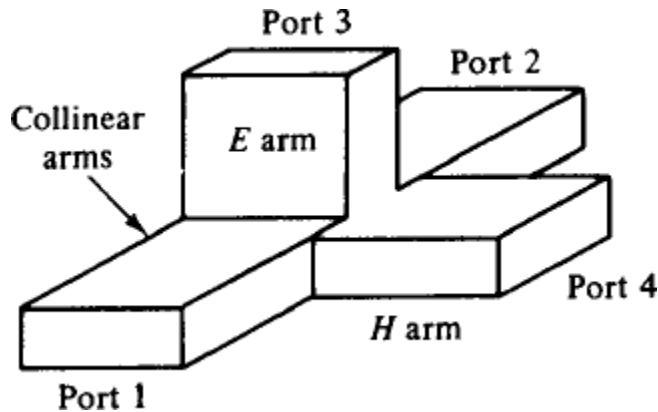


If two input waves are fed into port 1 and port 2 of the collinear arm, the output wave at port 3 will be in phase and additive .

If the input is fed into port 3, the wave will split equally into port 1 and port 2 in phase and in same magnitude .

## Magic Tee ( Hybrid Tees )

A magic tee is a combination of E-plane and H-plane tee. The characteristics of magic tee are:



- 1.If two waves of equal magnitude and same phase are fed into port 1 and port 2 the output will be zero at port 3 and additive at port 4.
- 2.If a wave is fed into port 4 it will be divided equally between port 1 and port 2 of the collinear arms and will not appear at port 3.
- 3.If a wave is fed into port 3 , it will produce an output of equal magnitude and opposite phase at port 1 and port 2. the output at port 4 is zero.
- 4.If a wave is fed into one of the collinear arms at port 1 and port 2, it will not appear in the other collinear arm at port 2 or 1 because the E-arm causes a phase delay while H arm causes a phase advance.

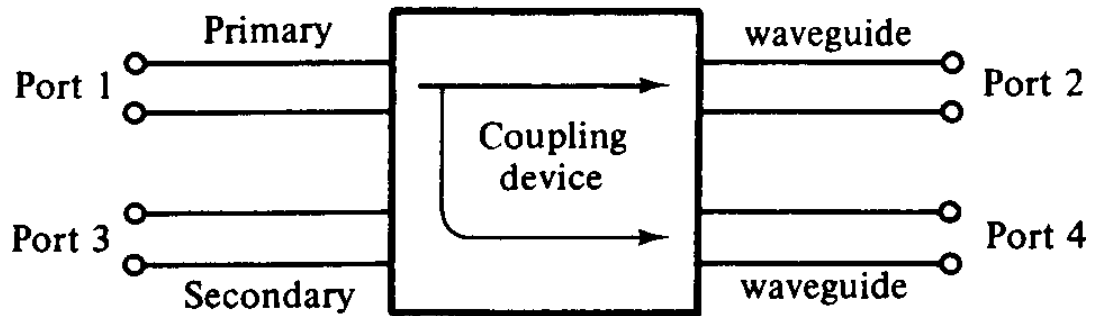
Therefore the **S** matrix of a magic tee can be expressed as

$$\mathbf{S} = \begin{bmatrix} 0 & 0 & S_{13} & S_{14} \\ 0 & 0 & S_{23} & S_{24} \\ S_{31} & S_{32} & 0 & 0 \\ S_{41} & S_{42} & 0 & 0 \end{bmatrix}$$

## DIRECTIONAL COUPLERS:

A directional coupler is a four-port waveguide junction as shown below. It consists of a primary waveguide 1-2 and a secondary waveguide 3-4. When all ports are terminated in their characteristic impedances, there is free transmission of the waves without reflection, between port 1 and port 2, and there is no transmission of power between port 1 and port 3 or between port 2 and port 4 because no coupling exists between these two pairs of ports. The degree of coupling between port 1 and port 4 and between port 2 and port 3 depends on the structure of the coupler.

The characteristics of a directional coupler can be expressed in terms of its Coupling factor and its directivity. Assuming that the wave is propagating from port 1 to port 2 in the primary line, the coupling factor and the directivity are defined,



Directional coupler.

where  $P_1$  = power input to port 1

$P_3$  = power output from port 3

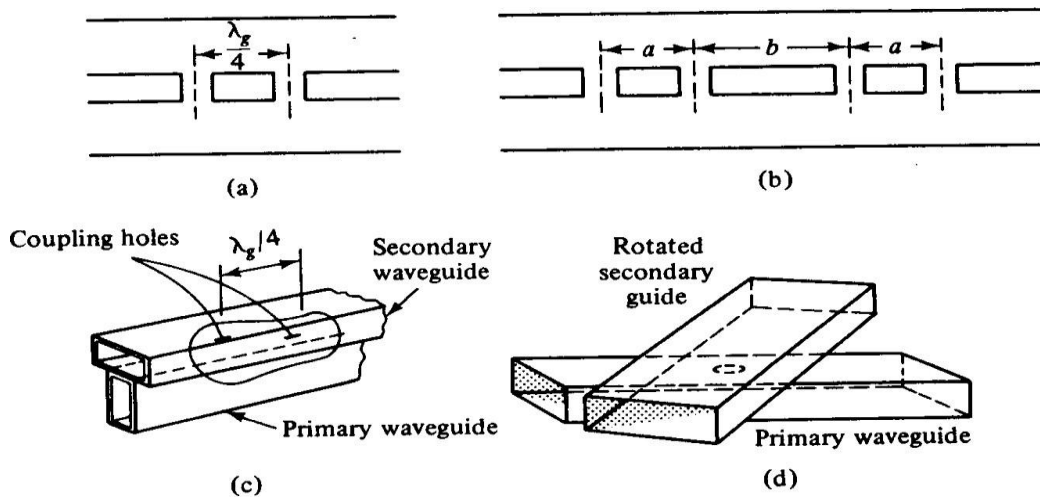
$P_4$  = power output from port 4

$$\text{Coupling factor (dB)} = 10 \log_{10} \frac{P_1}{P_4}$$

$$\text{Directivity (dB)} = 10 \log_{10} \frac{P_4}{P_3}$$

It should be noted that port 2, port 3, and port 4 are terminated in their characteristic impedances. The coupling factor is a measure of the ratio of power levels in the primary and secondary lines. Hence if the coupling factor is known, a fraction of power measured at port 4 may be used to determine the power input at port 1.

This significance is desirable for microwave power measurements because no disturbance, which may be caused by the power measurements, occurs in the primary line. The directivity is a measure of how well the forward traveling wave in the primary waveguide couples only to a specific port of the secondary waveguide ideal directional coupler should have infinite directivity. In other words, the power at port 3 must be zero because port 2 and port 4 are perfectly matched. Actually well- designed directional couplers have a directivity of only 30 to 35 dB. Several types of directional couplers exist, such as a two-hole directional coupler, four-hole directional coupler, reverse-coupling directional coupler, and Bethe-hole directional coupler the very commonly used two-hole directional coupler is described here.



**Figure 4-5-2** Different directional couplers. (a) Two-hole directional coupler. (b) Four-hole directional coupler. (c) Schwinger coupler. (d) Bethe-hole directional coupler.

### TWO HOLE DIRECTIONAL COUPLERS:

A two hole directional coupler with traveling wave propagating in it is illustrated. the spacing between the centers of two holes is

$$L = (2n + 1) \frac{\lambda_g}{4}$$

A fraction of the wave energy entered into port 1 passes through the holes and is radiated into the secondary guide as the holes act as slot antennas. The forward waves in the secondary guide are in same phase, regardless of the hole space and are added at port 4. The backward waves in the secondary guide are out of phase and are cancelled in port 3.

## S-matrix for Directional coupler:

The following characteristics are observed in an ideal Directional Coupler:

1. Since the directional coupler is a 4-port junction, the order of (S) matrix is 4 x 4 given by

$$[S]_{DC} = \begin{bmatrix} S_{11} & S_{12} & S_{13} & S_{14} \\ S_{21} & S_{22} & S_{23} & S_{24} \\ S_{31} & S_{32} & S_{33} & S_{34} \\ S_{41} & S_{42} & S_{43} & S_{44} \end{bmatrix}$$

2. Microwave power fed into port (1) cannot come out of port (3) as port (3) is the back port. Therefore the scattering coefficient  $S_{13}$  is zero...

$$S_{13} = 0$$

3. Because of the symmetry of the junction, an input power at port (2) cannot couple to port (4) as port (4) is the back-port for port (2)

$$S_{24} = 0$$

4. Let us assume that port (3) and (4) are perfectly matched to the junction so that

$$S_{33} = S_{44} = 0$$

Then, the remaining two ports will be "automatically" matched to the junction

$$S_{11} = S_{22} = 0$$

From the symmetric property of S matrix, we have

$$S_{ij} = S_{ji}$$

With the above characteristic values for S-parameters, the matrix of (5.125)

$$[S]_x = \begin{bmatrix} 0 & S_{12} & 0 & S_{14} \\ S_{12} & 0 & S_{23} & 0 \\ 0 & S_{23} & 0 & S_{34} \\ S_{14} & 0 & S_{34} & 0 \end{bmatrix}$$

becomes

From unitary property of equation we have

$$[\text{Since } S_{21} = S_{12}, S_{31} = S_{13} = 0, S_{32} = S_{23}, S_{41} = S_{14}, S_{42} = S_{24} = 0 \text{ and } S_{43} = S_{34}]$$

$$[S][S]^* = [U]$$

$$\begin{bmatrix} 0 & S_{12} & 0 & S_{14} \\ S_{12} & 0 & S_{23} & 0 \\ 0 & S_{23} & 0 & S_{34} \\ S_{14} & 0 & S_{34} & 0 \end{bmatrix} \begin{bmatrix} 0 & S_{12}^* & 0 & S_{14}^* \\ S_{12}^* & 0 & S_{23}^* & 0 \\ 0 & S_{23}^* & 0 & S_{34}^* \\ S_{14}^* & 0 & S_{34}^* & 0 \end{bmatrix} = \begin{bmatrix} 1 & 0 & 0 & 0 \\ 0 & 1 & 0 & 0 \\ 0 & 0 & 1 & 0 \\ 0 & 0 & 0 & 1 \end{bmatrix}$$



Considering 1<sup>st</sup> row and 1<sup>st</sup> column,

$$|S_{12}|^2 + |S_{14}|^2 = 1$$

Considering 2<sup>nd</sup> row and 2<sup>nd</sup> column,

$$|S_{12}|^2 + |S_{23}|^2 = 1$$

Considering 3<sup>rd</sup> row and 3<sup>rd</sup> column,

$$|S_{23}|^2 + |S_{34}|^2 = 1$$

Considering 1<sup>st</sup> row and 3<sup>rd</sup> column,

$$S_{12} S_{23}^* + S_{14} S_{34}^* = 0$$

Comparison of equations (5.133) and (5.134) yields

$$S_{14} = S_{23}$$

Comparing equations (5.134) and (5.135), we get

$$S_{12} = S_{34}$$

Let  $S_{12}$  be "*real and positive*" equal to  $p$

Then  $S_{34} = p = S_{34}^* = S_{12}$

Using equations (5.137) and (5.139) in (5.136), we get

$$S_{12} S_{23}^* + S_{23} S_{12} = 0$$

$$\therefore S_{12} (S_{23} + S_{23}^*) = 0$$

Since  $S_{12} \neq 0$ , we must have  $S_{23} + S_{23}^* = 0$

Equation (5.140) will be satisfied only when  $S_{23}$  is purely imaginary.

Let  $S_{23} = jq = S_{14}$

Using the above obtained values of S-parameters in the matrix of equation (5.131), we get

$$[S]_{DC} = \begin{bmatrix} 0 & p & 0 & jq \\ p & 0 & jq & 0 \\ 0 & jq & 0 & p \\ jq & 0 & p & 0 \end{bmatrix} \quad (5.142)$$

The relationship between p and q can be obtained from equation (5.133) as

$$p^2 + q^2 = 1 \quad (5.143)$$

The quantity 'p' is called the "**transmission factor**" and 'q' is called the "**coupling factor**".

## UNIT-3 MICROWAVE TUBES

### Limitations and Losses of conventional tubes at microwave frequencies

Following are the limitations of conventional active devices like transistors or tubes at microwave frequencies

#### 1) Interelectrode capacitance.

*What is interelectrode capacitance?*

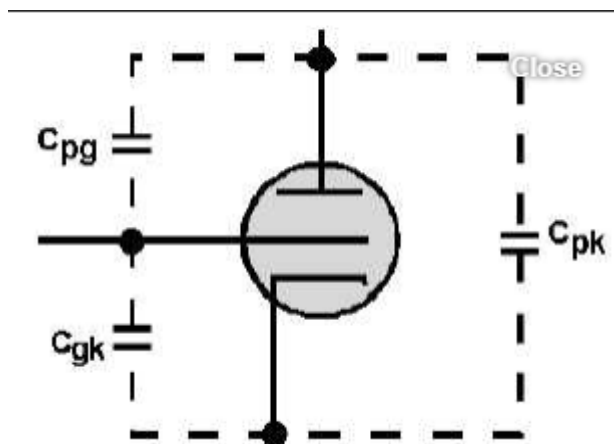
Vacuum has a dielectric constant of 1. As the elements of the triodes are made of metal and are separated by a dielectric, capacitance exists between them. This capacitance is interelectrode capacitance.

The capacitance between the plate and grid is  $C_{pg}$ . The grid-to-cathode capacitance is  $C_{gk}$ . The total capacitance across the tube is  $C_{pk}$ .

Now, we know that the capacitive reactance is given by

So as the input frequency increases, the effective grid to cathode impedance decreases due to decrease in reactance of interelectrode capacitance. At higher frequencies (greater than 100MHz) it becomes so small that signal is short circuited with the tube. Also, gain of the device reduces significantly.

This effect can be minimized by taking smaller (reducing the area) electrodes and by increasing distance between them (i.e. reducing capacitance because  $C = \epsilon \cdot A/d$ ) therefore by increasing reactance.

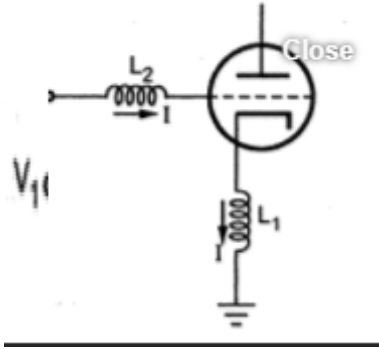


#### 2) Lead inductance.

Lead or stray inductance are effectively in parallel within the device with the interelectrode capacitance. Inductive reactance is given by:

$$X_L = 2 \pi f L$$

As the frequency increases, the effective reactance of the circuit also increases. This effect raises the frequency limit to the device. The inductance of cathode lead is common to both grid and plate circuits. This provides a path for degenerative feedback which reduces the overall efficiency of the circuit.



### 3) Transit time

Transit time is the time required for electrons to travel from the cathode to the plate. At low frequency, the transit time is very negligible. But, however at higher frequencies, transit time becomes an appreciable portion of a signal cycle which results in decrease in efficiency of device.

### 4) Gain bandwidth product

Gain bandwidth product is independent of frequency. So for a given tube higher gain can be only obtained at the expense of narrower bandwidth.

### 5) Skin effect

This effect is introduced at higher frequencies. Due to it, the current flows from the small sectional area to the surface of the device. Also at higher frequencies, resistance of conductor increases due to which there are losses.

$$R = \rho l (\sqrt{f})$$

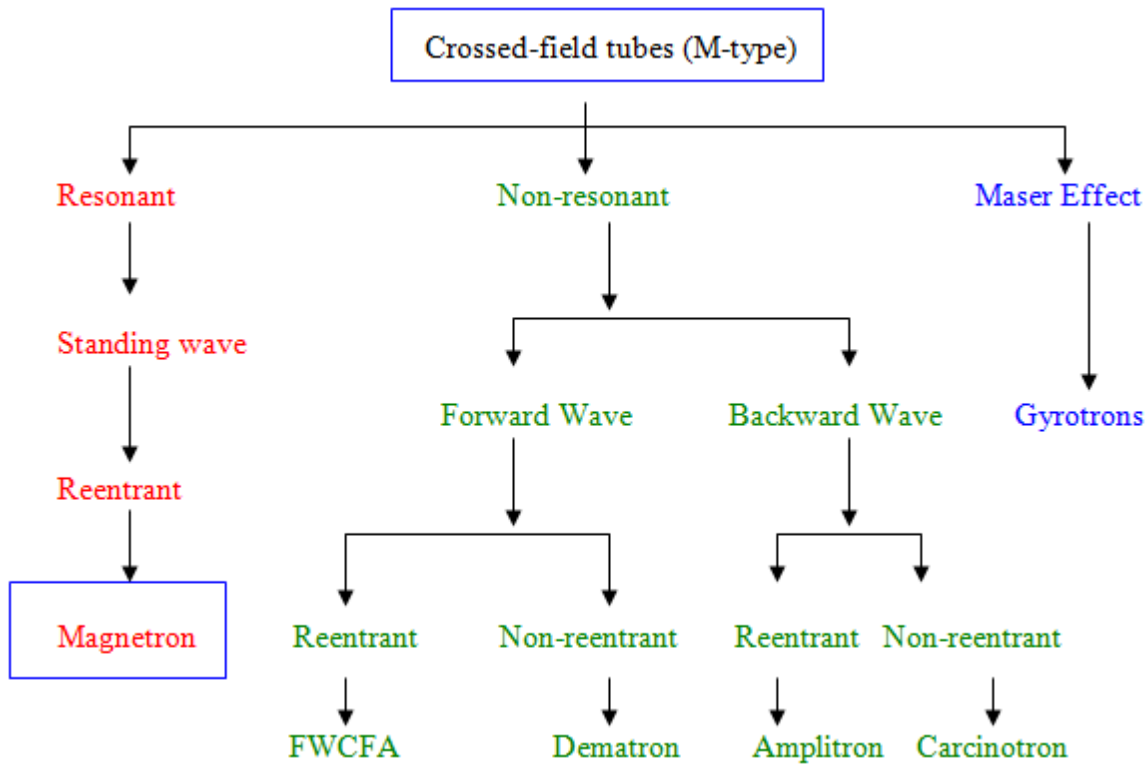
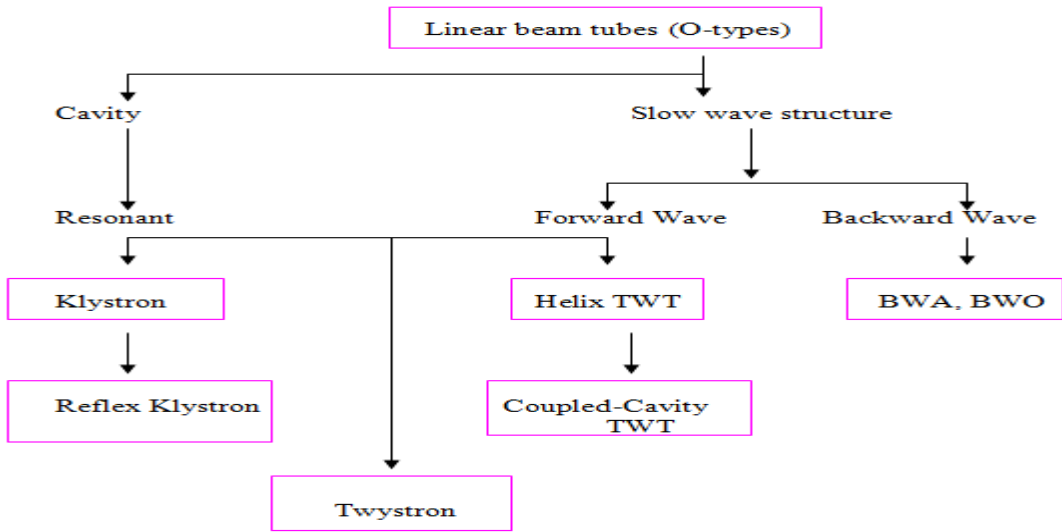
### 6) Dielectric loss

Dielectric material is generally different silicon plastic encapsulation materials used in microwave devices. At higher frequencies the losses due to these materials are also prominent.

### Microwave Tubes:

1. Linear beam tubes (O-type)-Dc magnetic field is in parallel with the dc electric field.

2. Crossed-field tubes (M-type)-Dc electric field and the dc magnetic field are perpendicular to each other.



## Cavity Klystrons

In microwave region, performs the functions of generates, receives and amplifies signals

### Configurations:

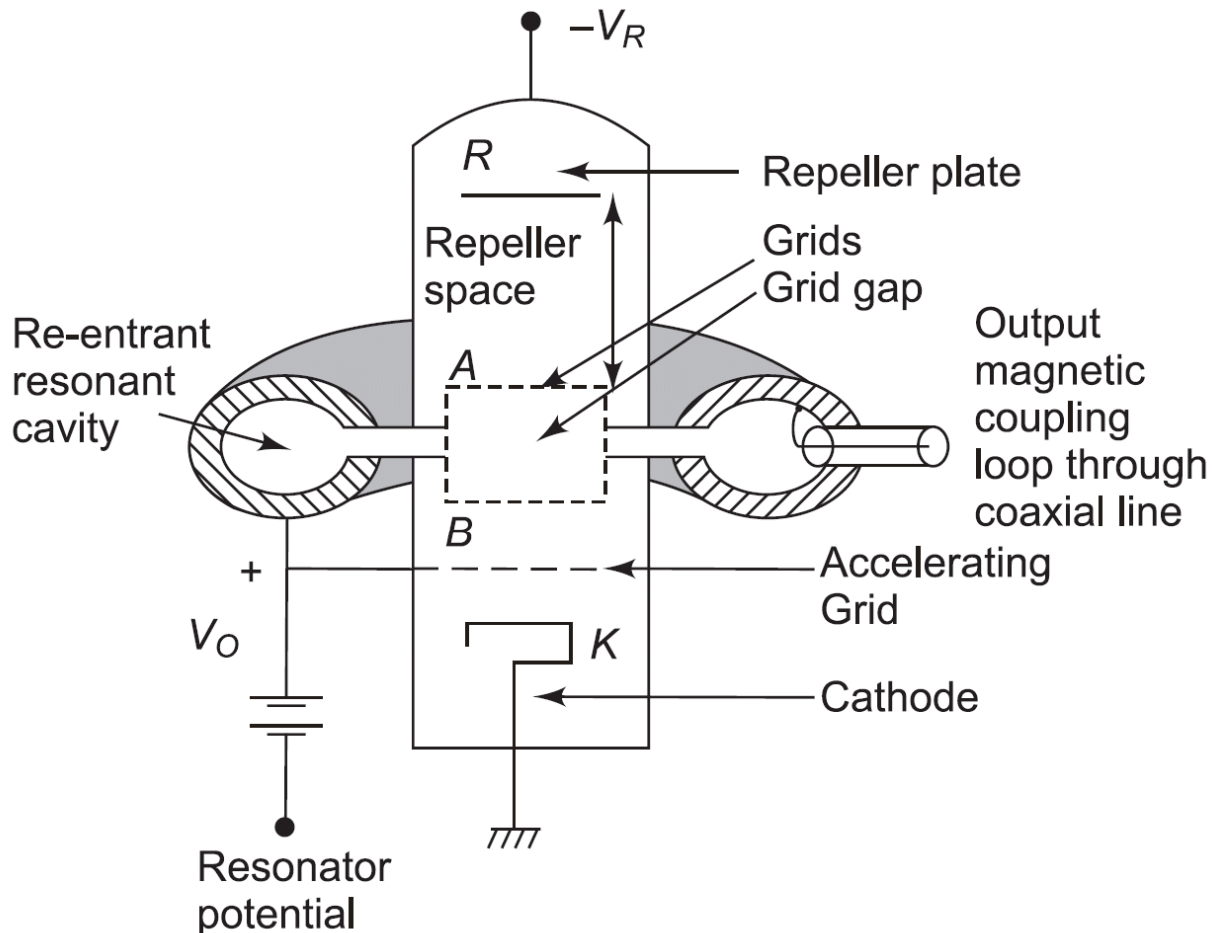
1. Reflex – low power microwave oscillator
2. Multicavity – low power microwave amplifier

### a) Reflex Klystron

- Has a reflector and one cavity as a resonator
- Reflex action of electron beam

#### Performance:

- Frequency range: 2-200 GHz
- BW:  $\pm 30$  MHz for  $V_R: \pm 10$  V
- Power o/p: 10mW – 2.5W
- used as microwave source in lab, microwave transmitter
- frequency modulation and amplitude modulation



**Fig. 9.3** *Functional diagram of a reflex klystron*

#### Mechanism of oscillation

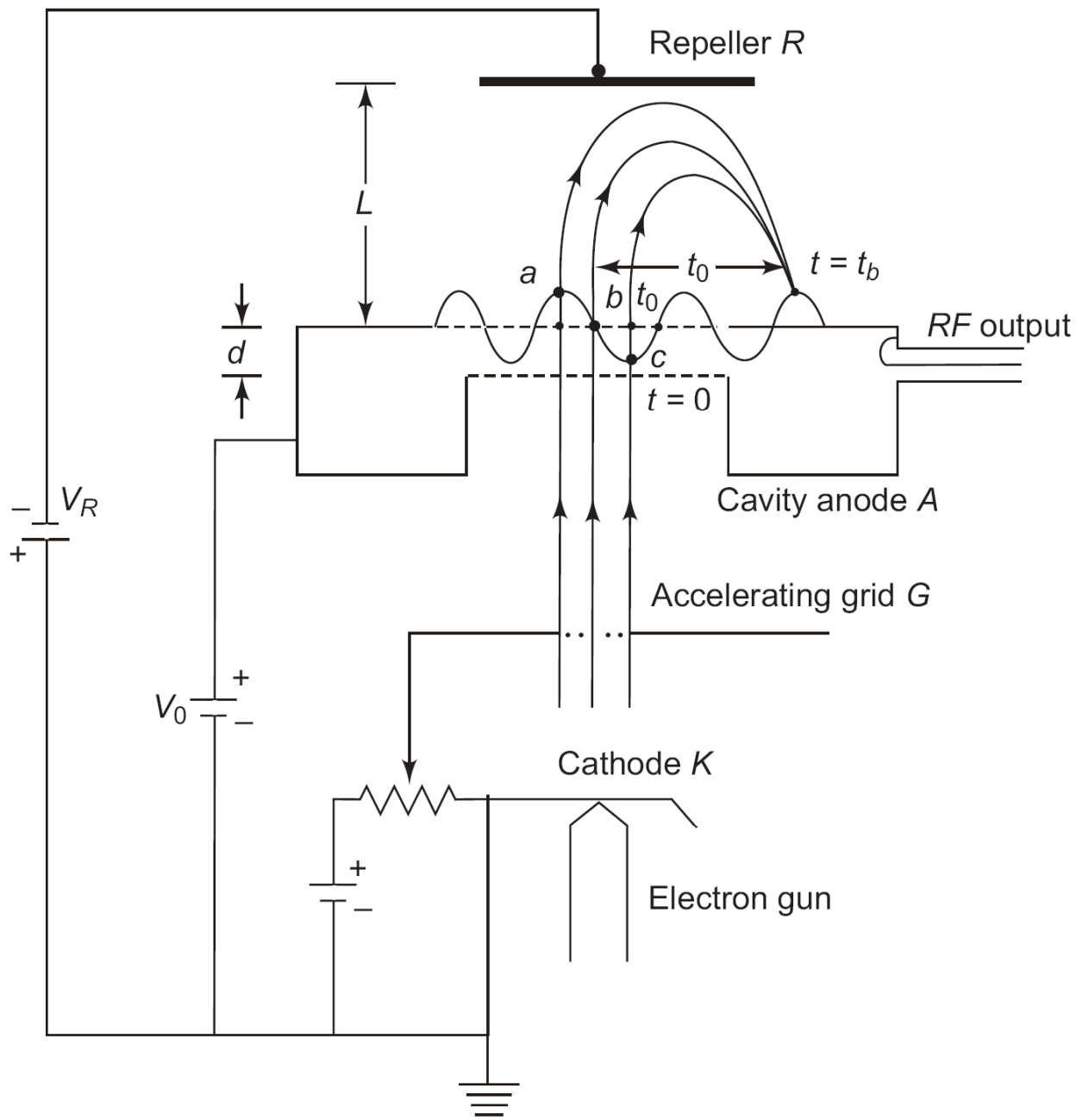
- \_ The electron passing through the cavity gap
- experience the RF field

\_ velocity modulated

a: Electrons which encountered the positive half cycle of the RF field in the cavity gap will be accelerated

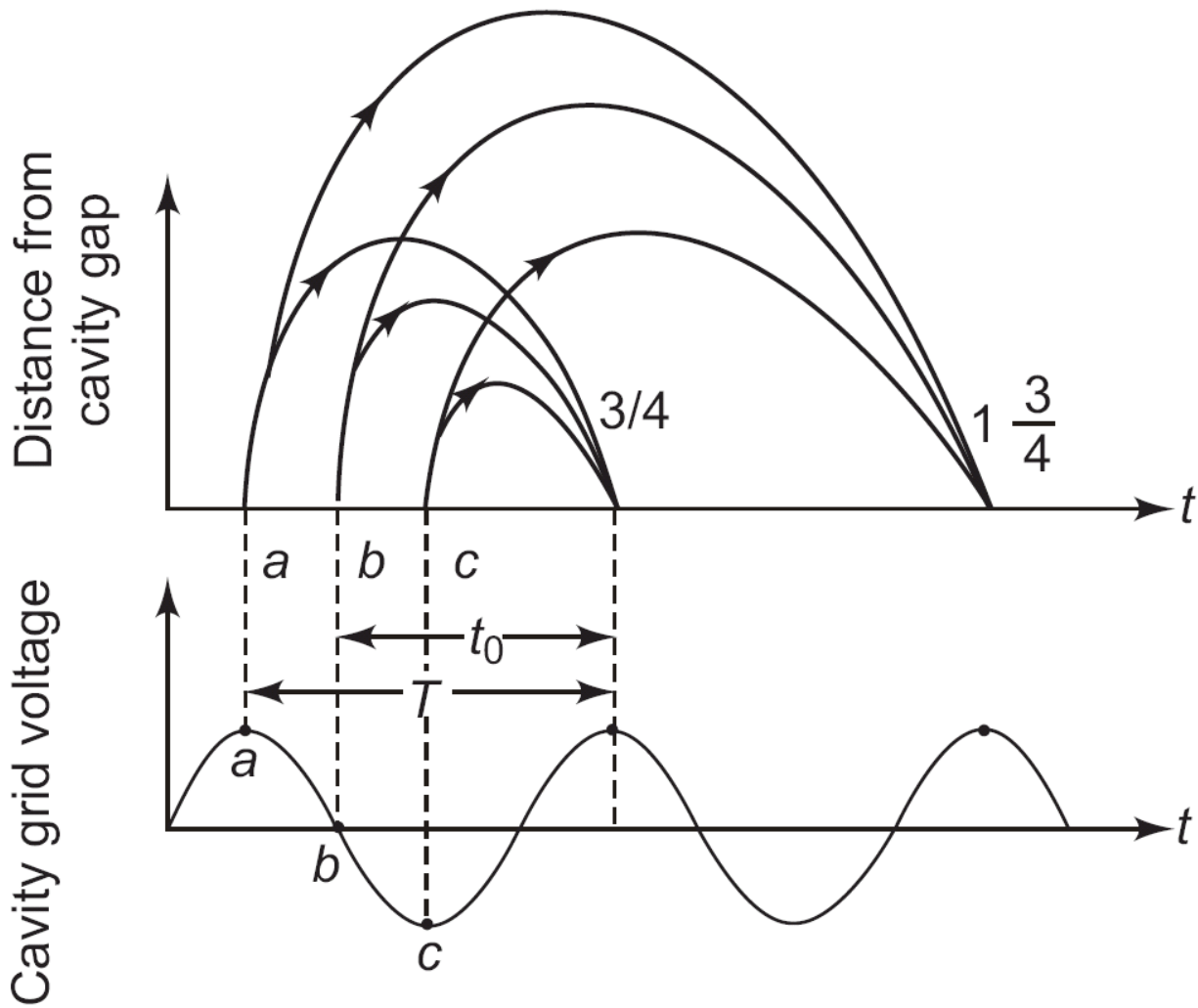
b: Electrons which encountered zero RF field will pass with unchanged original velocity

c: Electrons which encountered the negative half cycle will be retarded and entering the repeller space.



**Fig. 9.4** Reflex klystron operation

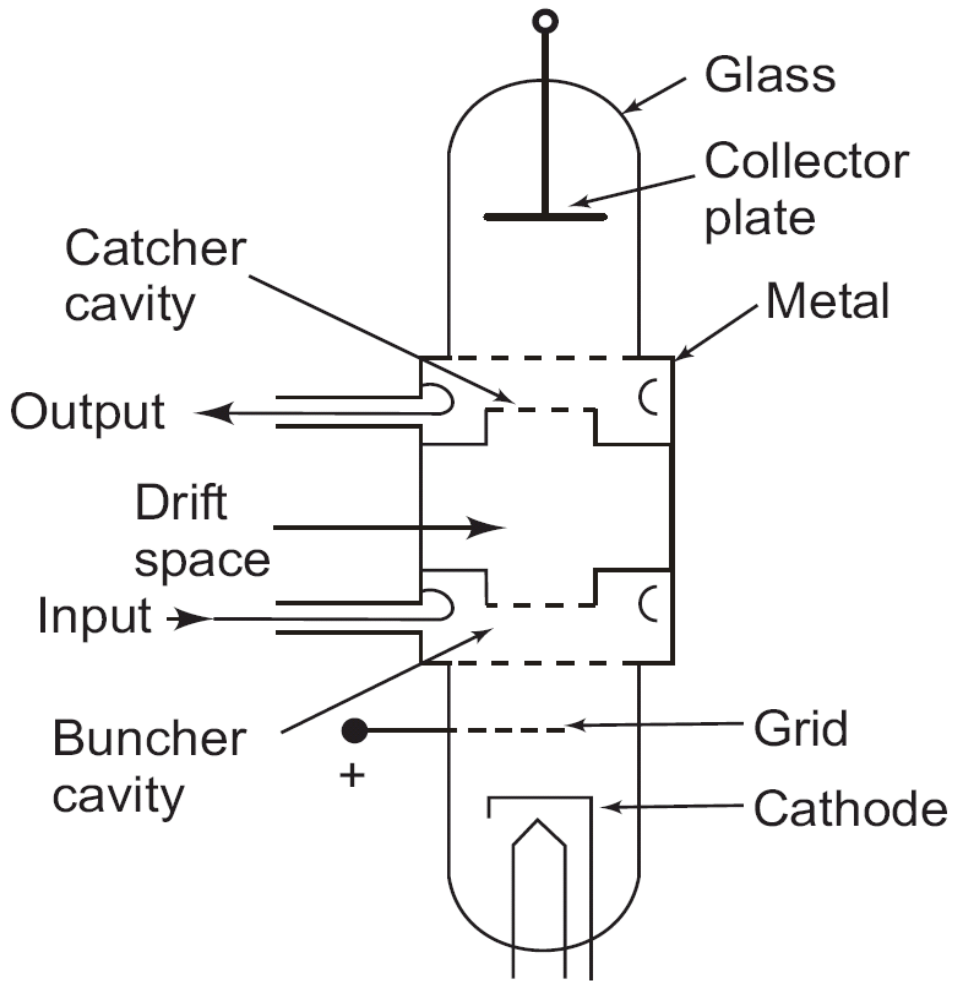




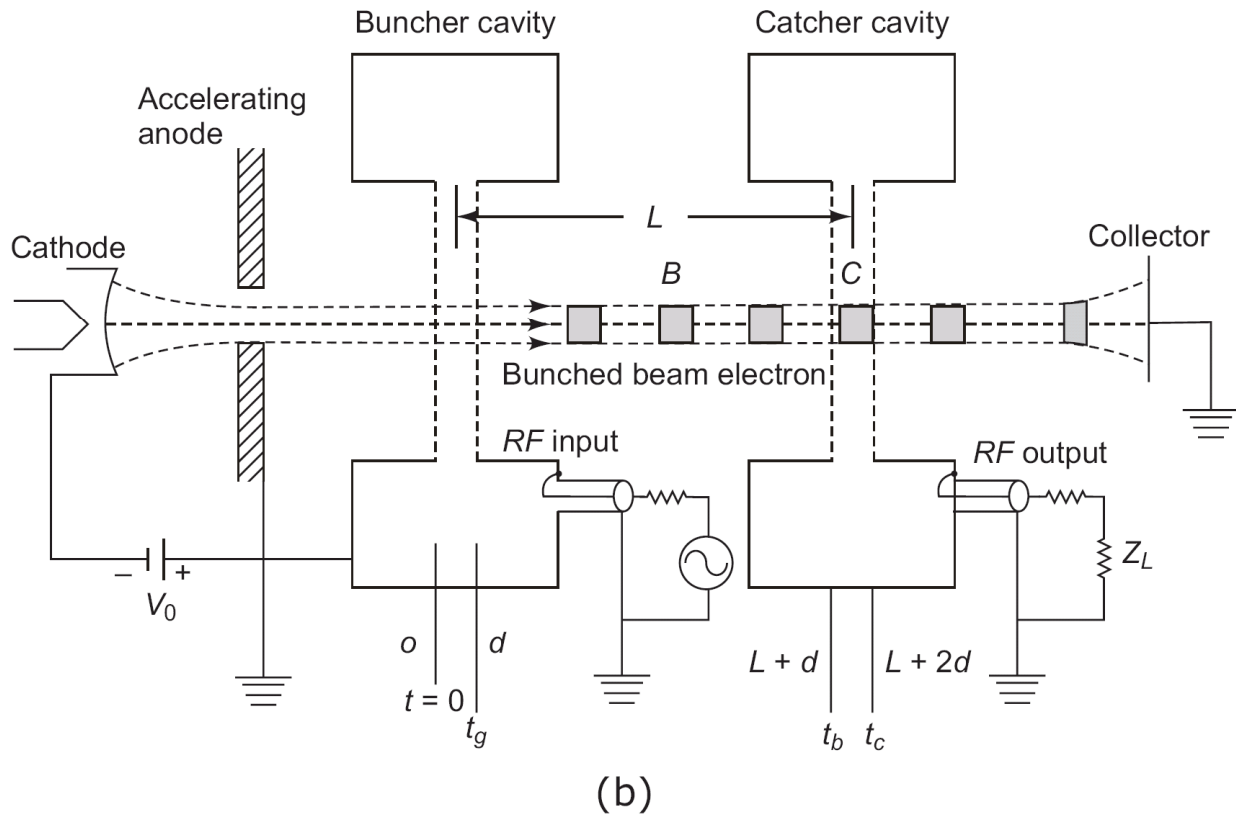
**Fig. 9.5** *Reflex klystron modes*

### Two cavity Klystron Amplifier

- \_ Assumption for RF amplification
- \_ Transit time in the cavity gap is very small compared to the period of the input RF signal cycle
- \_ Input RF signal amplitude is very small compared to the dc beam voltage
- \_ The cathode, anode, cavity grids and collectors are all parallel
- \_ No space charge or debunching take place at the bunch point
- \_ The RF fields are totally confined in the cavity gaps, zero in the drift space
- \_ Electrons leave the cathode with zero initial velocity



(a)

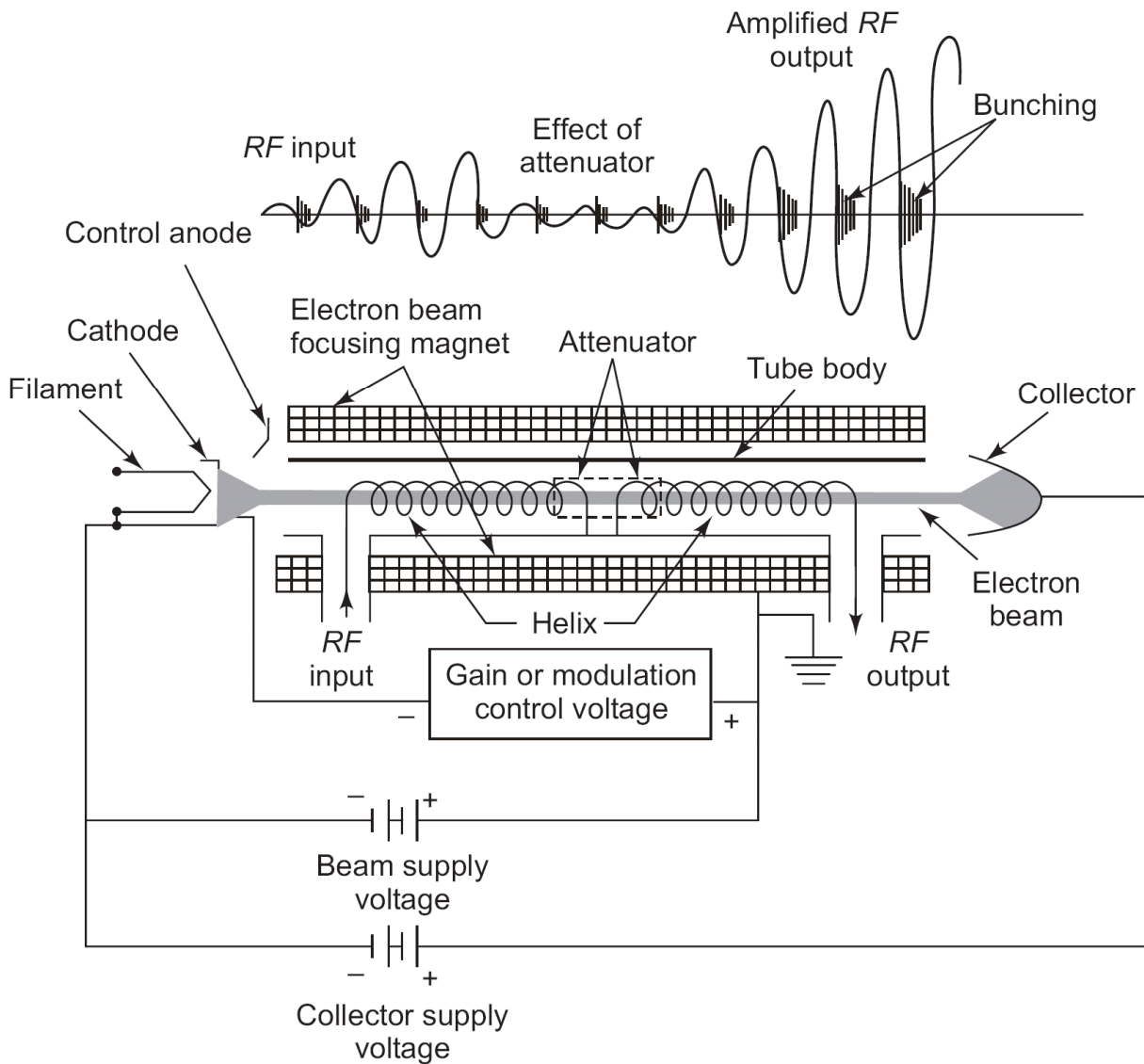


**Fig. 9.12** Two-cavity klystron amplifier: (a) Schematic diagram  
(b) Functional diagram

## Traveling wave tube (TWT)

### Travelling Wave Tube Amplifier:

- \_ High gain > 40 dB
- \_ Low NF < 10 dB
- \_ Wide Band > Octave
- \_ Frequency range: 0.3 – 50 GHz
  
- \_ Contains electron gun, RF interaction circuit, electron beam focusing magnet, collector
- \_ Amplify a weak RF input signal many thousands of times



**Fig. 9.18** TWT amplifier tube and circuit

a) Electron gun

\_ To get as much electron current flowing into as small a region as possible without distortion or fuzzy edges

Sources of electrons for the beam- 6 elements:

- gun shells
- heater
- cathode
- control grid
- focus electrode
- anode

b) RF interaction circuit

- \_ Interaction structures : helix, ring bar, ringloop, coupled cavity
- \_ RF circuit – complex trade off analysis, based on many interlocking parameters
- \_ Low power level : helix
- \_ Medium power level : ring loop, ring bar
- \_ Power level & frequency increased: RF losses on the circuit become more appreciable.

c) Electron beam focusing

- \_ A magnetic field – to hold the electron beam together as it travels through the interaction structure of the tube
- \_ The beam tends to disperse or spread out as a result of the natural repulsive forces between electrons.
- \_ Methods of magnetic focusing
  - \_ Solenoid magnetic structure
  - \_ Permanent magnet
  - \_ Periodic permanent magnet (PPM)
  - \_ Radial magnet PPM

d) The collector

- \_ To dissipate the electrons in the form of heat as they emerge from the slow wave structure
- \_ Accomplished by thermal conduction to a colder outside surface – the heat is absorbed by circulated air or a liquid

1. Gain compression

- \_ the amount of gain decrease from the small signal condition (normally 6dB)

2. Beam Voltage

- \_ the voltage between the cathode and the RF structure

3. Synchronous Voltage

- \_ the beam voltage necessary to obtain the greatest interaction between the electrons in the electron beam and the RF wave on the circuit

4. Gain

- \_ the ratio of RF output power to RF input power (dB)

5. Phase Characteristic

- \_ Phase shift – the phase of output signal relative to the input signal
- \_ Phase sensitivity – the rate of phase change with a specific operating parameter

## UNIT- IV

### TRANSFER ELECTRON DEVICES

#### INTRODUCTION:

The application of two-terminal semiconductor devices at microwave frequencies has been increased usage during the past decades. The CW, average, and peak power outputs of these devices at higher microwave frequencies are much larger than those obtainable with the best power transistor. The common characteristic of all active two-terminal solid-state devices is their negative resistance. The real part of their impedance is negative over a range of frequencies. In a positive resistance the current through the resistance and the voltage across it are in phase. The voltage drop across a positive resistance is positive and a power of  $(I^2 R)$  is dissipated in the resistance.

In a negative resistance, however, the current and voltage are out of phase by  $180^\circ$ . The voltage drop across a negative resistance is negative, and a power of  $(-I^2 R)$  is generated by the power supply associated with the negative resistance. In positive resistances absorb power (passive devices), whereas negative resistances generate power (active devices). In this chapter the transferred electron devices (TEDs) are analyzed.

The differences between microwave transistors and transferred electron devices (TEDs) are fundamental. Transistors operate with either junctions or gates, but TEDs are bulk devices having no junctions or gates. The majority of transistors are fabricated from elemental semiconductors, such as silicon or germanium, whereas TEDs are fabricated from compound semiconductors, such as gallium arsenide (GaAs), indium phosphide (InP), or cadmium telluride (CdTe). Transistors operate as "warm" electrons whose energy is not much greater than the thermal energy  $0.026\text{eV}$  at room temperature of electrons in the semiconductors.

#### GUNN EFFECT DIODES – GaAs diode

Gunn effect diodes are named after J. B. Gunn who in 1963 discovered a periodic fluctuation of current passing through the n-type gallium arsenide when the applied voltage exceeded a certain critical value.

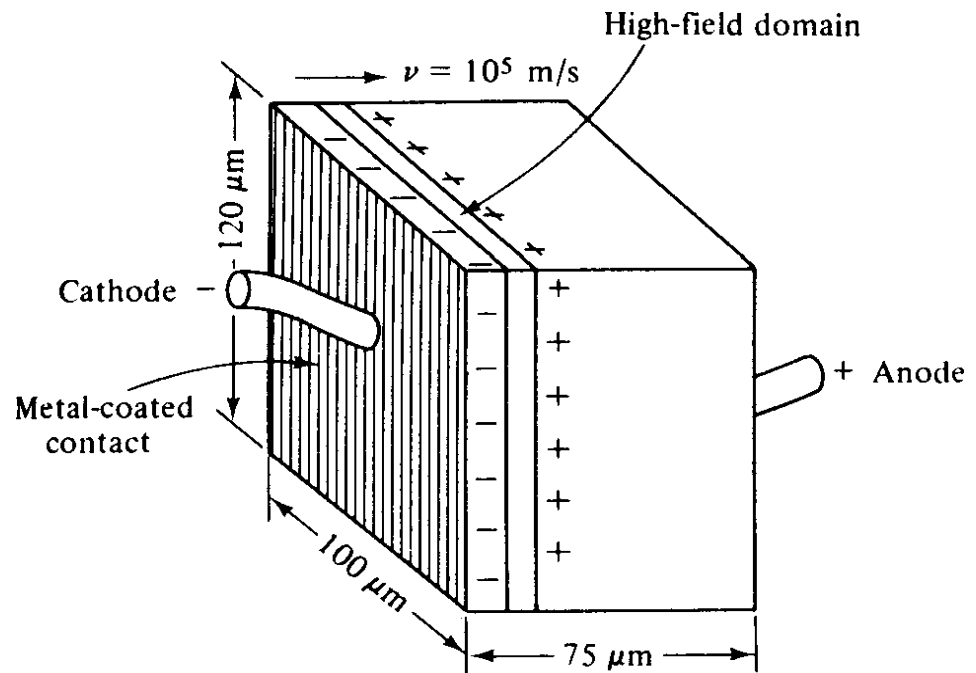
Shockley in 1954 suggested that the two terminal negative resistance devices using semiconductors had advantages over transistors at high frequencies.

In 1961 , Ridley and Watkins described a new method for obtaining negative differential mobility in semiconductors. The principle involved is to heat carriers in a light mass , low mobility , higher energy sub band when they have a high temperature.

Finally Kroemer stated that the origin of the negative differential mobility is Ridley Watkins Hilsum's mechanism of electron transfer into the valleys that occur in conduction bands.

### **Gunn effect:**

The below figure shows the diagram of a uniform n-type GaAs diode with ohmic contacts at the end surfaces. Gunn stated that “ Above some critical voltage , corresponding to an electric field of 2000 to 4000 Volts/cm, the current in every specimen became a fluctuating function of time.



### **Gunn Diodes**

Single piece of GaAs or Inp and contains no junctions Exhibits negative

differential resistance

### ***Applications:***

low-noise local oscillators for mixers (2 to 140 GHz). Low-power transmitters and wide band tunable sources

Continuous-wave (CW) power levels of up to several hundred mill watts can be obtained in the X-, Ku-, and Ka-bands. A power output of 30 mW can be achieved from commercially available devices at 94 GHz.

Higher power can be achieved by combining several devices in a power combiner.

Gunn oscillators exhibit very low dc-to-RF efficiency of 1 to 4%.

Gunn also discovered that the threshold electric field  $E_{th}$  varied with the length and type of material. He developed an elaborate capacitive probe for plotting the electric field distribution within a specimen of n-type GaAs of length  $L = 210 \mu\text{m}$  and cross-sectional area  $3.5 \times 10^{-3} \text{ cm}^2$  with a low-field resistance of  $16 \Omega$ .

Current instabilities occurred at specimen voltages above 59 V, which means that the threshold field is

$$E_{th} = \frac{V}{L} = \frac{59}{210 \times 10^{-6} \times 10^2} = 2810 \text{ volts/cm}$$

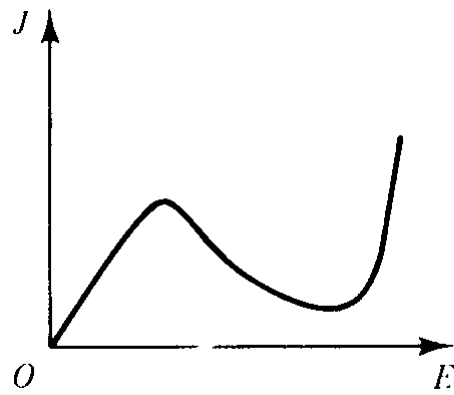
### **RIDLEY WATKINS AND HILSUM THEORY:**

Many explanations have been offered for the Gunn effect. In 1964 Kroemer [6] suggested that Gunn's observations were in complete agreement with the Ridley- Watkins-Hilsum (RWH) theory.

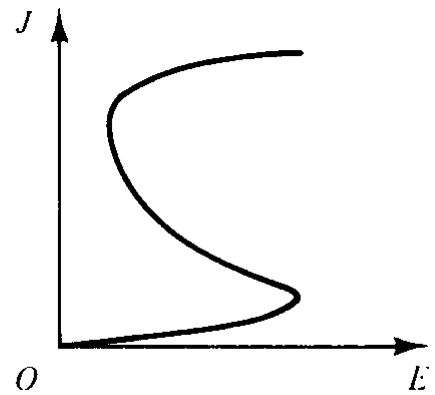
### **Differential Negative Resistance:**

The fundamental concept of the Ridley-Watkins-Hilsum (RWH) theory is the differential negative resistance developed in a bulk solid-state III-V compound when either a voltage (or electric field) or a current is applied to the terminals of the sample. There are two modes of negative-resistance devices: voltage- controlled and current controlled Modes.



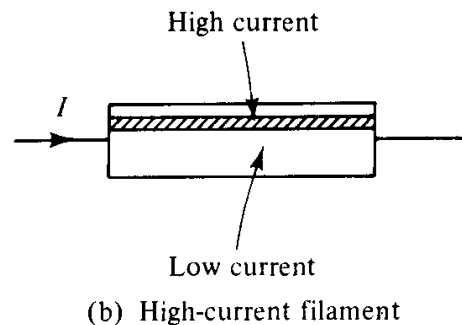
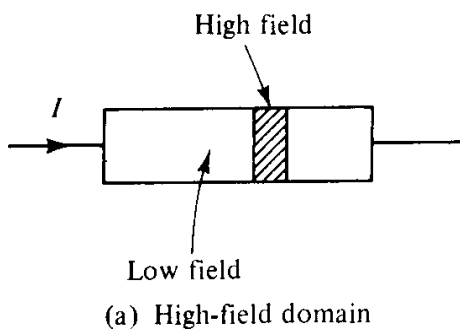


(a) Voltage-controlled mode



(b) Current-controlled mode

In the voltage-controlled mode the current density can be multivalued, whereas in the current-controlled mode the voltage can be multivalued. The major effect of the appearance of a differential negative-resistance region in the current density field curve is to render the sample electrically unstable. As a result, the initially homogeneous sample becomes electrically heterogeneous in an attempt to reach stability. In the voltage-controlled negative-resistance mode high-field domains are formed, separating two low-field regions. The interfaces separating low and high-field domains lie along equi potentials; thus they are in planes perpendicular to the current direction.

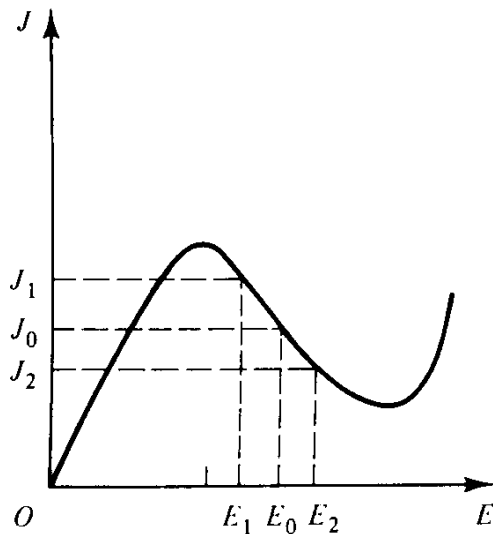


Expressed mathematically, the negative resistance of the sample at a particular region is

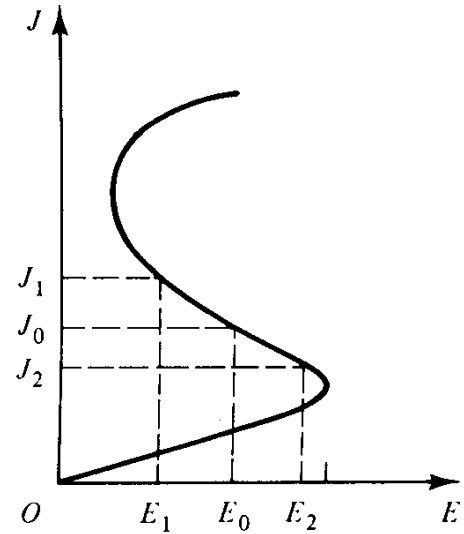
$$\frac{dI}{dV} = \frac{dJ}{dE} = \text{negative resistance}$$

If an electric field  $E_0$  (or voltage  $V_0$ ) is applied to the sample, for example, the current density  $J_0$  is generated.

As the applied field (or voltage) is increased to  $E_1$  (or  $V_1$ ), the current density is decreased to  $J_1$ . When the field (or voltage) is decreased to  $E_2$  (or  $V_2$ ), the current density is increased to  $J_2$ . These phenomena of the voltage controlled negative resistance are shown in Fig. 7-2-3(a). Similarly, for the current controlled mode, the negative-resistance profile is as shown below.



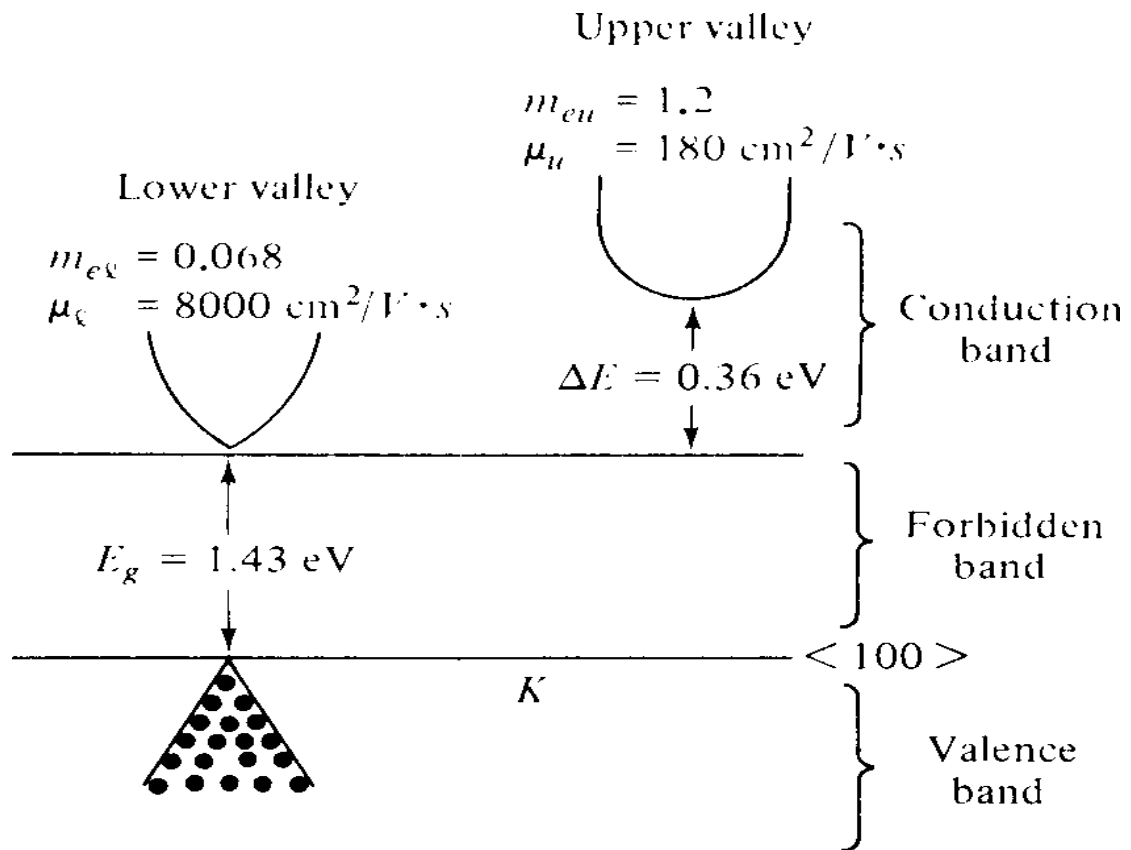
(a) Voltage-controlled mode



(b) Current-controlled mode

### TWO VALLEY MODEL THEORY:

Kroemer proposed a negative mass microwave amplifier in 1958 [10] and 1959 [11]. According to the energy band theory of the  $n$ -type GaAs, a high-mobility lower valley is separated by an energy of 0.36 eV from a low-mobility upper valley

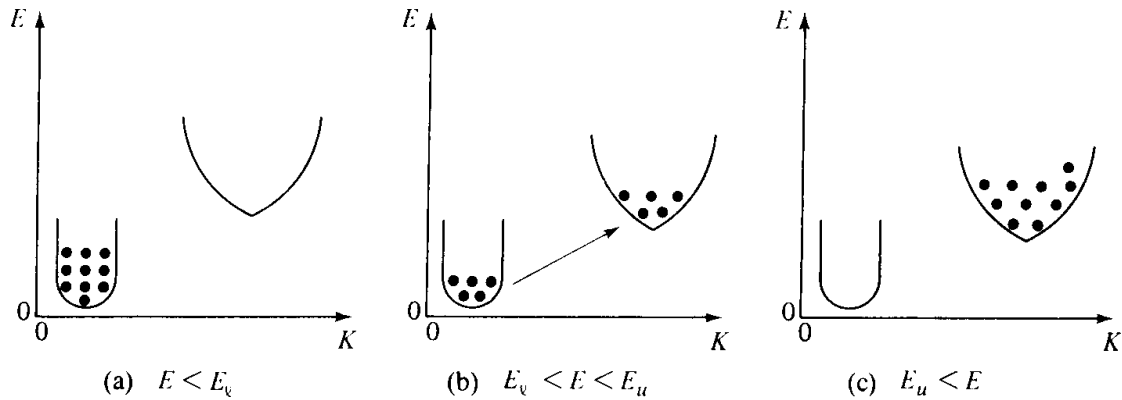


Electron densities in the lower and upper valleys remain the same under an Equilibrium condition. When the applied electric field is lower than the electric field of the lower valley ( $E < E_{\ell}$ ), no electrons will transfer to the upper valley.

When the applied electric field is higher than that of the lower valley and lower than that of the upper valley ( $E_{\ell} < E < E_u$ ), electrons will begin to transfer to the upper valley.

when the applied electric field is higher than that of the upper valley ( $E_u < E$ ), all electrons will transfer to the upper valley.

When a sufficiently high field  $E$  is applied to the specimen, electrons are accelerated and their effective temperature rises above the lattice temperature also increases. Thus electron density  $I$  and are both functions of electric field  $E$ .



## Transfer of electron densities.

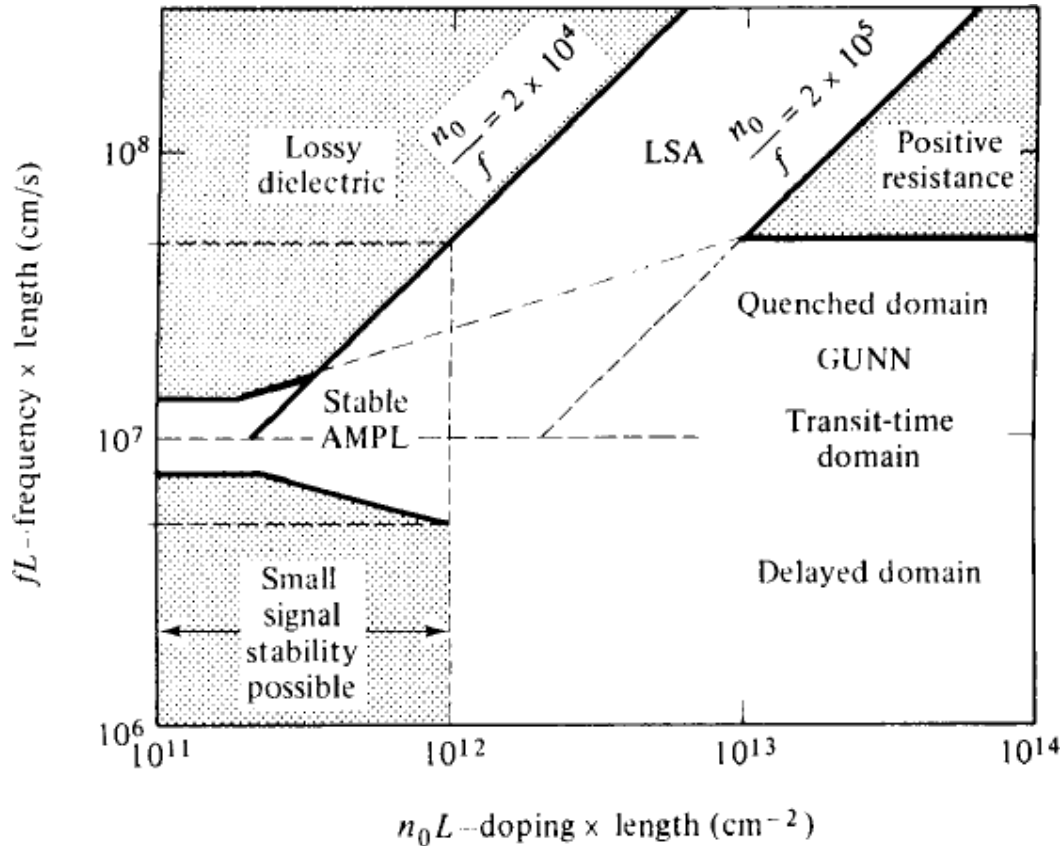
### MODES OF OPERATION OF GUNN DIODE:

A Gunn diode can operate in four modes:

1. Gunn oscillation mode
2. stable amplification mode
3. LSA oscillation mode
4. Bias circuit oscillation mode

**Gunn oscillation mode:** This mode is defined in the region where the product of frequency multiplied by length is about  $10^7$  cm/s and the product of doping multiplied by length is greater than  $10^{12}$ /cm<sup>2</sup>. In this region the device is unstable because of the cyclic formation of either the accumulation layer or the high field domain.

When the device is operated as a relatively high Q cavity and coupled properly to the load, the domain is quenched or delayed before nucleating.

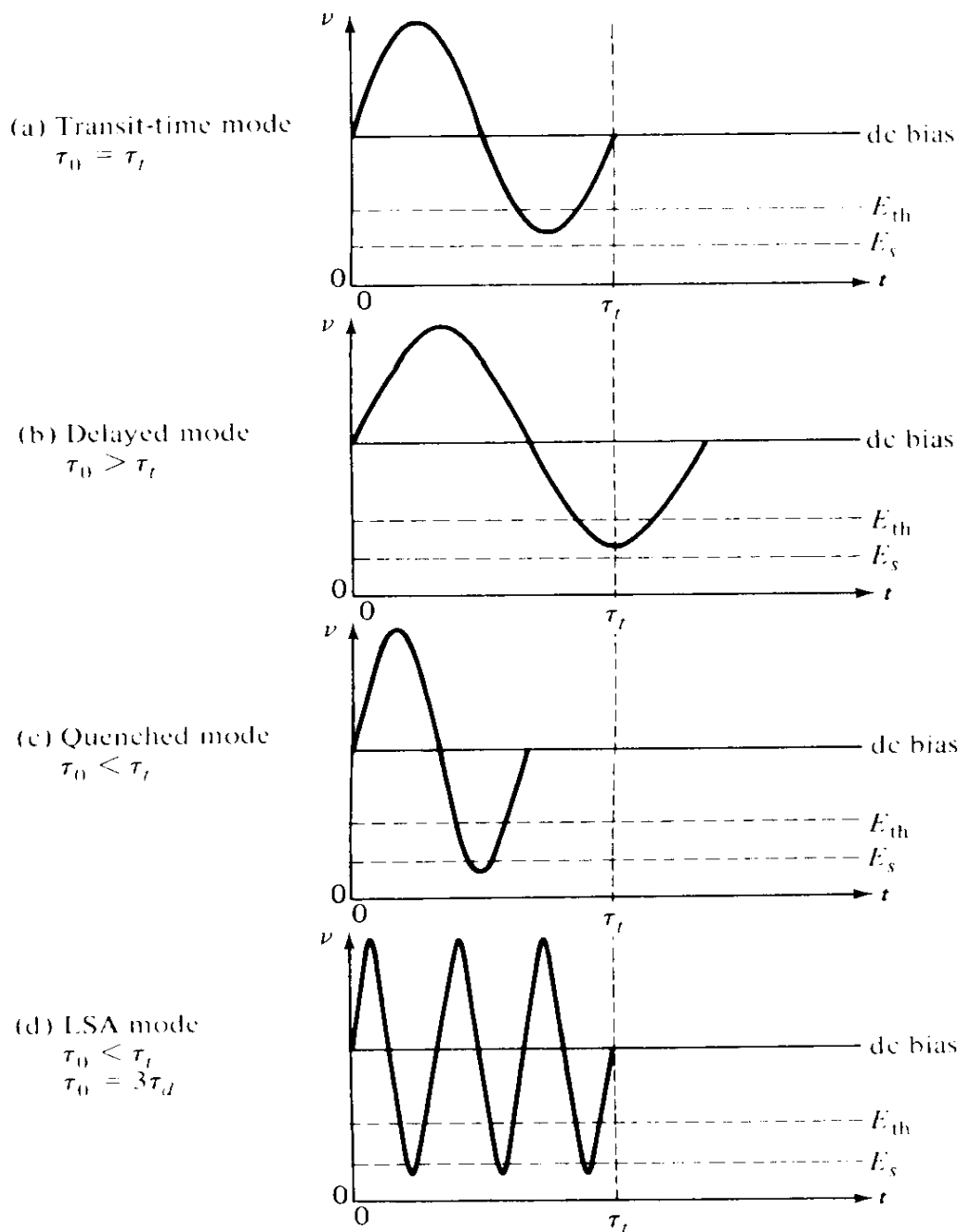


**2. Stable amplification mode:** This mode is defined in the region where the product of frequency times length is about  $10^7$  *cmls* and the product of doping times length is between  $10^{11}$  and  $10^{12}/\text{cm}^2$

**3. LSA oscillation mode:** This mode is defined in the region where the product of frequency times length is above  $10^7$  *cmls* and the quotient of doping divided by frequency is between  $2 \times 10^4$  and  $2 \times 10^5$ .

**4. Bias-circuit oscillation mode:** This mode occurs only when there is either Gunn or LSA oscillation, and it is usually at the region where the product of frequency times length is too small to appear in the figure. When a bulk diode is biased to threshold, the average current suddenly drops as Gunn oscillation begins.

The drop in current at the threshold can lead to oscillations in the bias circuit that are typically 1 kHz to 100 MHz .



*Delayed domain mode* ( $106 \text{ cm/s} < fL < 107 \text{ cm/s}$ ). When the transit time is Chosen so that the domain is collected while  $E < E_{th}$  as shown in Fig. 7-3-4(b), a new domain cannot form until the field rises above threshold again. In this case, the oscillation period is greater than the transit time-that is,  $T_o > T$ . This delayed mode is also called *inhibited mode*. The efficiency of this mode is about 20%.

*Quenched domain mode* ( $fL > 2 \times 10^7$  cm/s).

If the bias field drops below the sustaining field  $E_s$  during the negative half-cycle as shown, the domain collapses before it reaches the anode. When the bias field swings back above threshold, a new domain is nucleated and the process repeats. Therefore the oscillations occur at the frequency of the resonant circuit rather than at the transit-time frequency. It has been found that the resonant frequency of the circuit is several times the transit-time frequency, since one dipole does not have enough time to readjust and absorb the voltage of the other dipoles. Theoretically, the efficiency of quenched domain oscillators can reach 13%

## LSA MODE

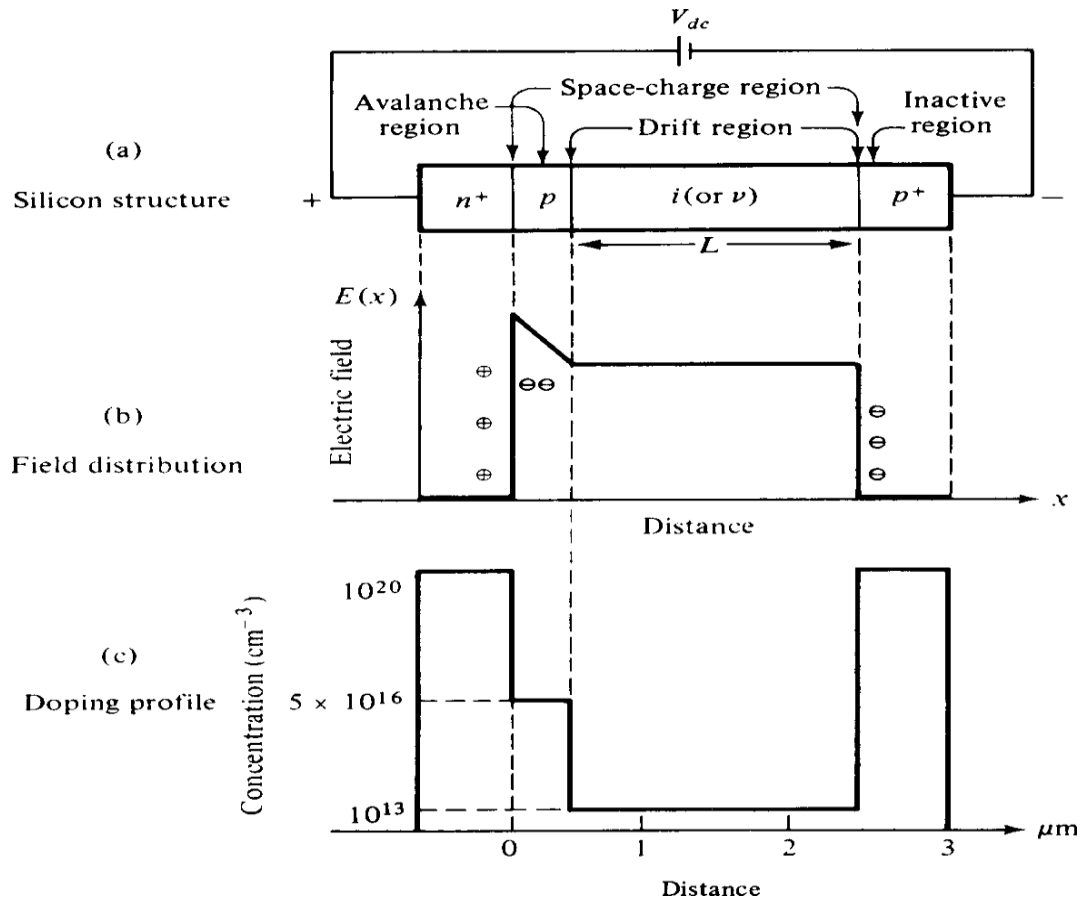
When the frequency is very high, the domains do not have sufficient time to form. While the field is above threshold. As a result, most of the domains are maintained in the negative conductance state during a large fraction of the voltage cycle. Any accumulation of electrons near the cathode has time to collapse while the signal is below threshold. Thus the LSA mode is the simplest mode of operation.

## AVALANCHE TRANSIT TIME DEVICES:

### READ DIODE:

Read diode was the first proposed avalanche diode. The basic operating principles of IMPATT diode can be easily understood by first understanding the operation of read diode.

The basic read diode consists of four layers namely  $n^+ p i p^+$  layers. The plus superscript refers to very high doping levels and 'i' denotes intrinsic layer. A large reverse bias is applied across diode. The avalanche multiplication occurs in the thin "p" region which is also called the high field region or avalanche region.



The holes generated during the avalanche process drift through the intrinsic region while moving towards  $p^+$  contact. The region between  $n^+$   $p$  junction and the  $i$ - $p^+$  junction is known as space charge region.

When this diode is reverse biased and placed inside an inductive microwave cavity microwave oscillations are produced due to the resonant action of the capacitive impedance of the diode and cavity inductance. The dc bias power is converted into microwave power by that read diode oscillator.

Avalanche multiplication occurs when the applied reverse bias voltage is greater than the breakdown voltage so that the space charge region extends from  $n^+$  $p$  junction through the  $p$  and  $i$  regions, to the  $i$  to  $p^+$  junction.

### IMPATT DIODE:

Impatt diodes are manufactured having different forms such as  $n^+pip^+$ ,  $p^+nin^+$ ,  $p^+nn^+$  abrupt junction and  $p^+i$   $n^+$  diode configuration. The material used for manufacture of these modes are either Germanium, Silicon, Gallium Arsenide (GaAs) or Indium Phosphide (In P).

Out of these materials, highest efficiency, higher operating frequency and lower noise is obtained with GaAs. But the disadvantage with GaAs is complex fabrication process and hence higher cost. The figure below shows a reverse biased  $n^+ pi p^+$  diode with electric field variation, doping concentration versus distance plot, the microwave voltage swing and the current variation.



## PRINICPLE OF OPERATION:

When a reverse bias voltage exceeding the breakdown voltage is applied, a high electric field appears across the n+ p junction. This high field intensity imparts sufficient energy to the valence electrons to raise themselves into the conduction band. This results avalanche multiplication of hole-electron pairs. With suitable doping profile design, it is possible to make electric field to have a very sharp peak in the close vicinity of the junction resulting in "impact avalanche multiplication". This is a cumulative process resulting in rapid increase of carrier density. To prevent the diode from burning, a constant bias source is used to maintain average current at safe limit 10, The diode current is contributed by the conduction electrons which move to the n+ region and the associated holes which drift through the steady field and a.c. field. The diode ~wings into and out of avalanche conditions under the influence of that reverse bias steady field and the a.c. field.

Due to the drift *time* of holes being' small, carriers drift to the end contacts before the a.c. voltage swings the diode out of the avalanche Due to building up of oscillations, the a.c. field takes energy from the applied bias lid the oscillations at microwave frequencies are sustained across the diode. Due to this a.c. field, the hole current grows exponentially to a maximum and again decays exponentially to Zero.

During this hole drifting process, a constant electron current is induced in the external Circuit which starts flowing when hole current reaches its peak and continues for half cycle Corresponding to negative swing of the a.c. voltage as shown in figure Thus a 180 degrees Phase shift between the external current and a.c. microwave voltage provides a negative Resistance for sustained oscillations.

The resonator is usually tuned to this frequency so that the IMPATI diodes provide a High power continuous wave (CW) and pulsed microwave signals.

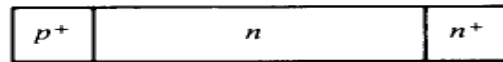
$$\theta = \omega\tau = \omega \frac{L}{v_d}$$

$$\omega_r \equiv \left( \frac{2\alpha' v_d I_0}{\epsilon_s A} \right)^{1/2}$$

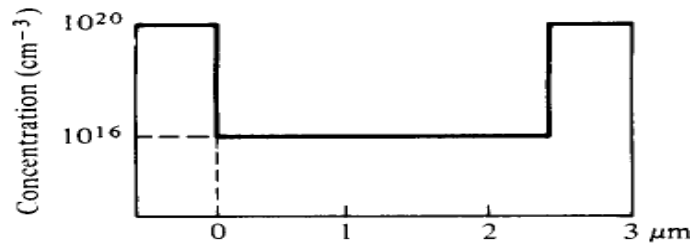
## Applications of IMPATT Diodes

- (i) Used in the final power stage of solid state microwave transmitters for communication purpose.
- (ii) Used in the transmitter of TV system.
- (iii) Used in FDM/TDM systems.
- (iv) Used as a microwave source in laboratory for measurement purposes.

(a) Abrupt  $p-n$  junction



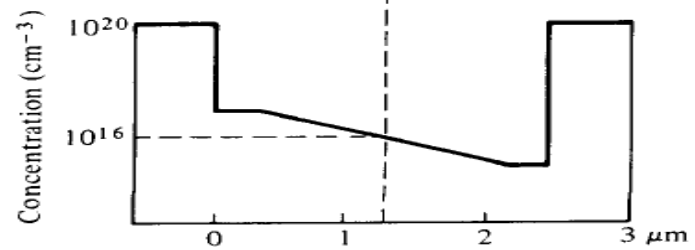
Doping profile



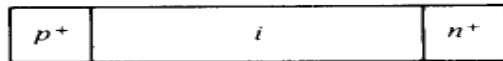
(b) Linearly graded  $p-n$  junction



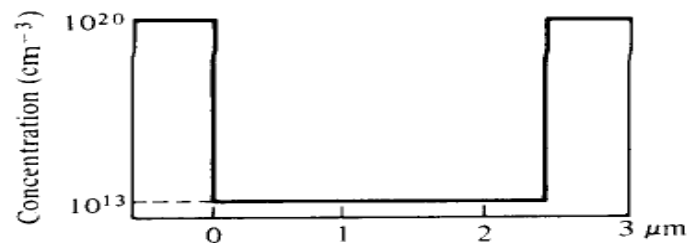
Doping profile



(c)  $p-i-n$  diode



Doping profile



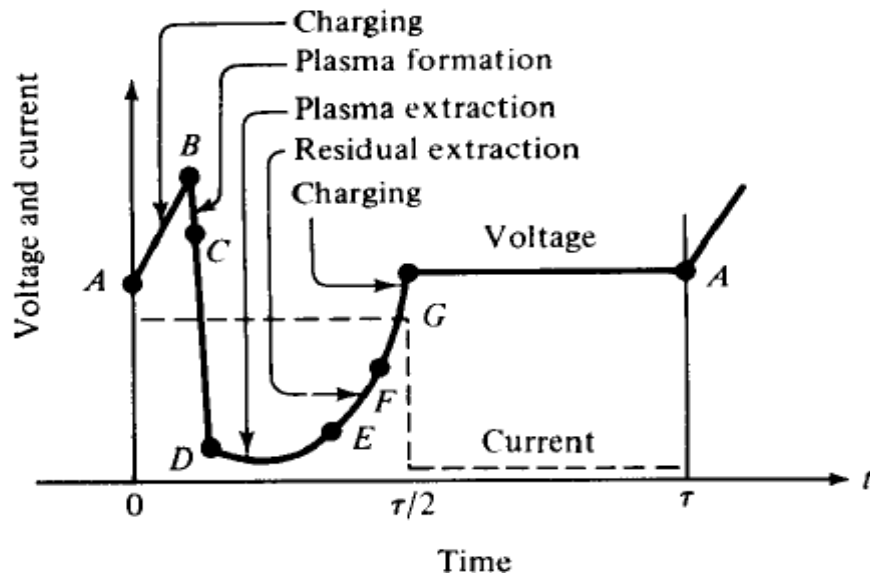
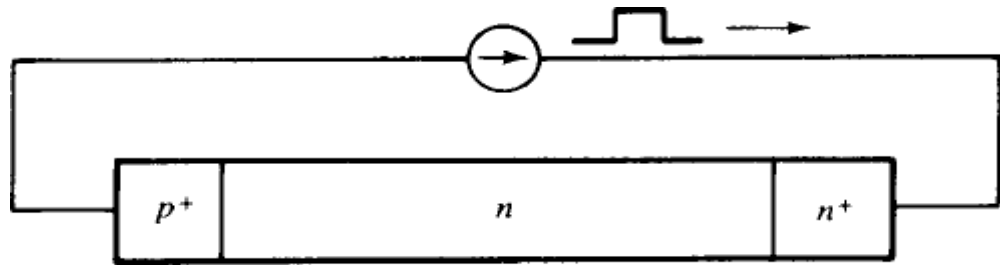
## **TRAPATT DIODE:**

Silicon is usually used for the manufacture of TRAPATT diodes and have a configuration of p+ n n+ as shown .The p-N junction is reverse biased beyond the breakdown region, so that the current density is larger. This decreases the electric field in the space charge region and increases the carrier transit time. Due to this, the frequency of operation gets lowered to less than 10 GHz. But the efficiency gets increased due to low power dissipation.

Inside a co-axial resonator, the TRAPATT diode is normally mounted at a point where maximum RF voltage swing is obtained. When the combined dc bias and RF voltage exceeds breakdown voltage, avalanche occurs and a plasma of holes and electrons are generated which gets trapped. When the external circuit current flows, the voltage rises and the trapped plasma gets released producing current pulse across the drift space. The total transit time is the sum of the drift time and the delay introduced by the release of the trapped plasma. Due to this longer transit time, the operating frequency is limited to 10 GHz. Because the current pulse is associated with low voltage, the power dissipation is low resulting in higher efficiency.

The disadvantages of TRAPATT are high noise figure and generation of strong harmonics due to short duration of the current pulse.

TRAPATT diode finds application in S-band pulsed transmitters for pulsed array radar systems.



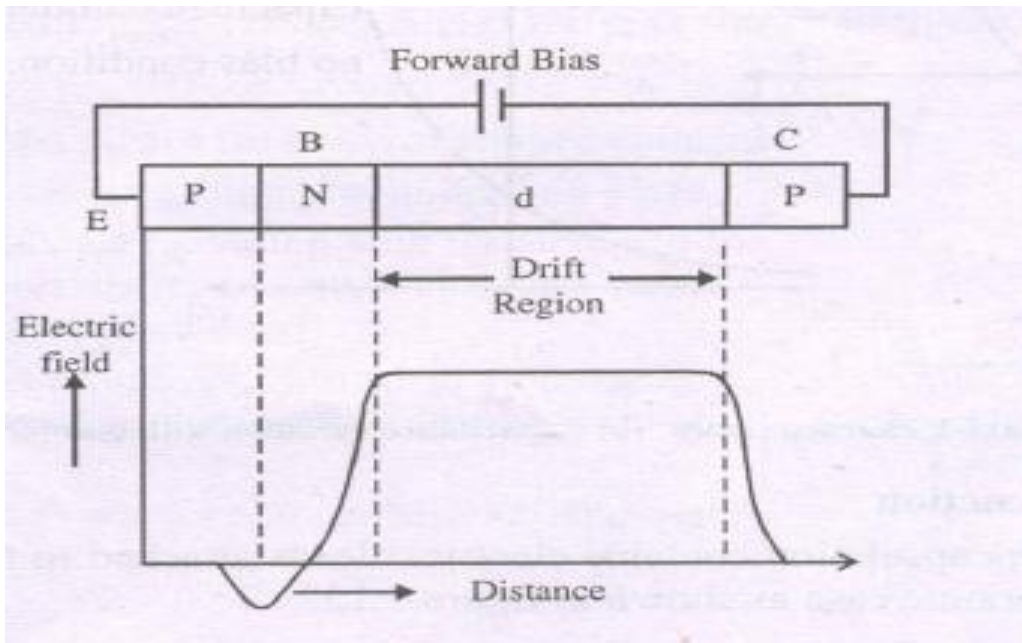
The electric field is expressed as

$$E(x, t) = E_m - \frac{qN_A}{\epsilon_s} x + \frac{Jt}{\epsilon_s}$$

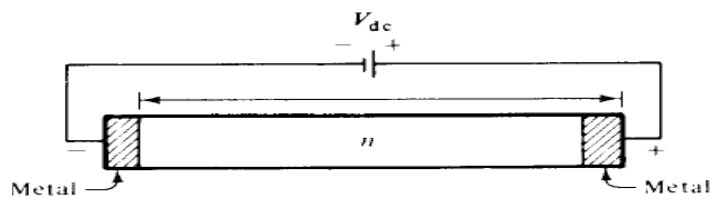
**BARITT DIODE ( Barrier injection transmit time devices ):**

BARITT devices are an improved version of IMPATT devices. IMPATT devices employ impact ionization techniques which is too noisy. Hence in order to achieve low noise figures, impact ionization is avoided in BARRITT devices. The minority injection is provided by punch-through of the intermediate region (depletion region). The process is basically of lower noise than impact ionization responsible for current injection in an IMPATT. The negative resistance is obtained on account of the drift of the injected holes to the collector end of the arial.

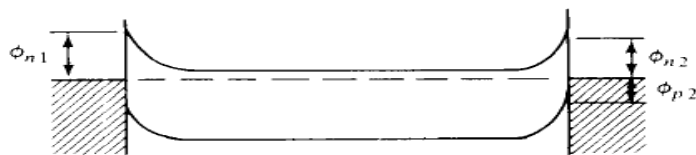
The construction of a BARITT device consisting of emitter, base, intermediate or drift or depleted region and collector. An essential requirement for the BARITT device is therefore that the intermediate drift region be entirely depleted to cause punch through to the emitter-base junction without causing avalanche breakdown of the base-collector junction.



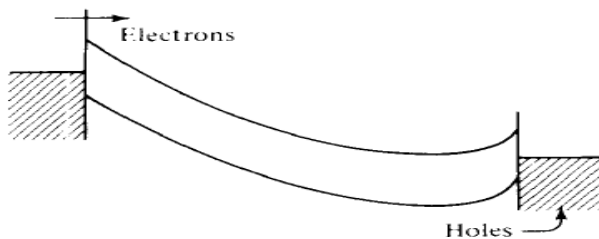
The parasitic should be kept as low as possible. The equivalent circuit depends on the type of encapsulation and mounting make. For many applications, there should be a large capacitance variation, small value of minimum capacitance and series resistance  $R_s$ . Operation is normally limited to  $f/10$  [25 GHz for Si and 90 GHz for GaAs]. Frequency of operation beyond  $(f/10)$  leads to increase in  $R$ , decrease in efficiency and increase in noise.



(a) M-n-M diode



(b) Energy band diagram in thermal equilibrium



(c) Energy band under bias condition

## UNIT- V

### ATTENUATORS:

In order to control power levels in a microwave system by partially absorbing the transmitted microwave signal, attenuators are employed. Resistive films (dielectric glass slab coated with aquadag) are used in the design of both fixed and variable attenuators. A co-axial fixed attenuator uses the dielectric lossy material inside the centre conductor of the co-axial line to absorb some of the centre conductor microwave power propagating through it dielectric rod decides the amount of attenuation introduced. The microwave power absorbed by the lossy material is dissipated as heat.

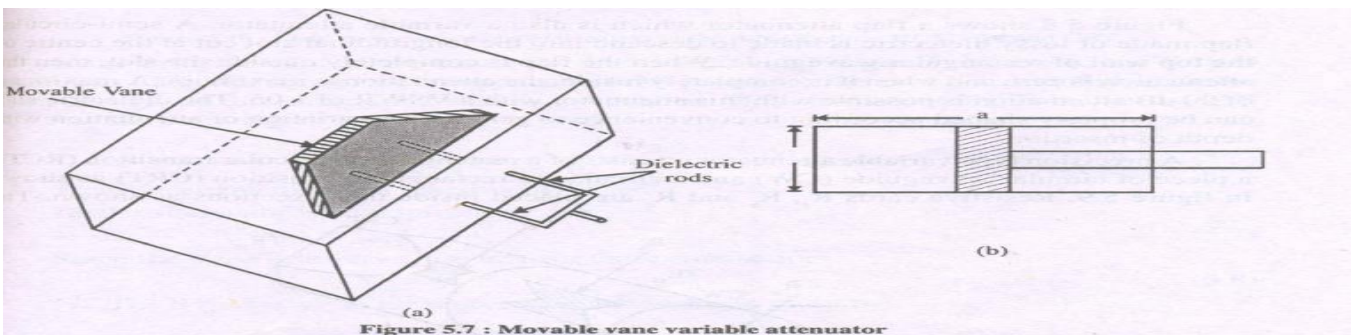
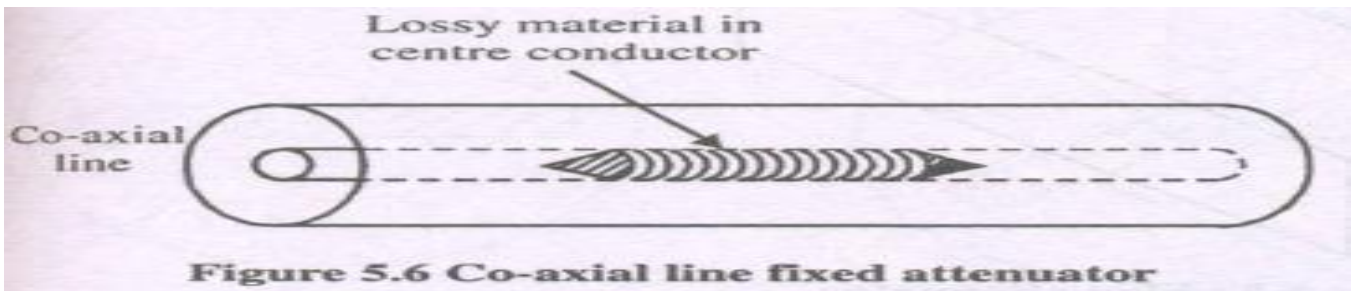


Figure 5.8 shows a flap attenuator which is also a variable attenuator. A semi-circular flap made of lossy dielectric is made to descend into the longitudinal slot cut at the centre of the top wall of rectangular waveguide. When the flap is completely outside the slot, then the attenuation is zero and when it is completely

inside, the attenuation is maximum. A maximum direction of 90 dB attenuation is possible with this attenuator with a VSWR of 1.05. The dielectric slab can be properly shaped according to convenience to get a linear variation of attenuation within the depth of insertion.

A precision type variable attenuator consists of a rectangular to circular transition (ReT), a piece of circular waveguide (CW) and a circular-to-rectangular transition

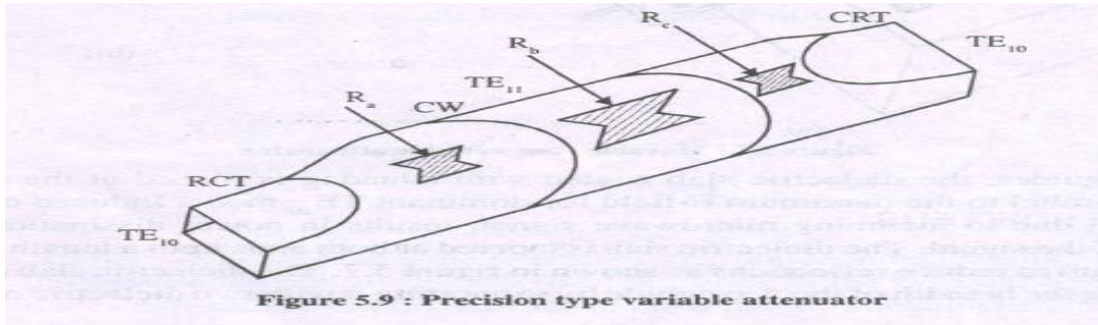


Figure 5.9 : Precision type variable attenuator

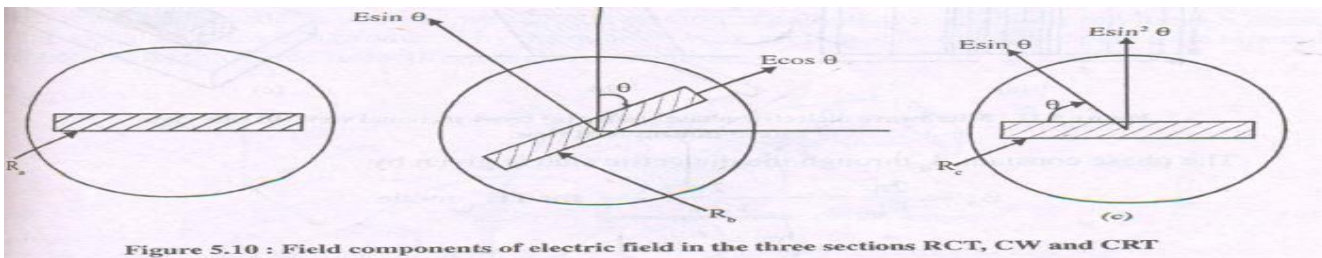


Figure 5.10 : Field components of electric field in the three sections RCT, CW and CRT

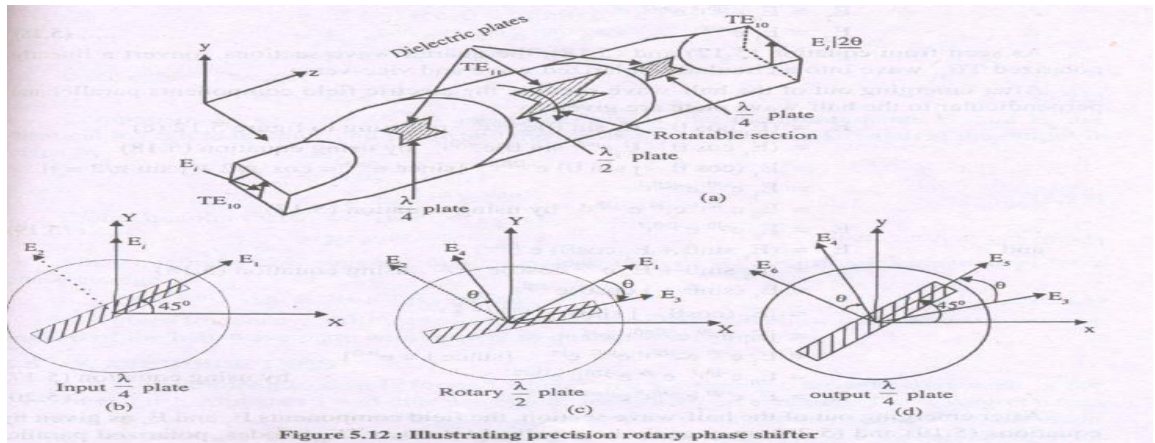
### PHASE SHIFTERS:

A microwave phase shifter is a two port device which produces a variable shift in phase of the incoming microwave signal. A lossless dielectric slab when placed inside the rectangular waveguide produces a phase shift.

#### PRECISION PHASE SHIFTER

The rotary type of precision phase shifter is shown in figure 5.12 which consists of a circular waveguide containing a lossless dielectric plate of length  $2l$  called "half-wave section", a section of rectangular-to-circular transition containing a lossless dielectric plate of length  $l$ , called "quarter-wave section", oriented at an angle of  $45^\circ$  to the broader wall of the rectangular waveguide and a circular-to-rectangular transition again containing a

lossless dielectric plate of same length  $l$  (quarter wave section) oriented at an angle  $45^\circ$ . The incident TE<sub>10</sub> mode becomes TELL mode in circular waveguide section. The half-wave section produces a phase shift equal to twice that produced by the quarter wave section. The dielectric plates are tapered at both ends to reduce reflections due to discontinuity.



When TE<sub>10</sub> mode is propagated through the input rectangular waveguide of the rectangular to circular transition, then it is converted into TELL in the circular waveguide section. Let  $E_0$  be the maximum electric field strength of this mode which is resolved into components,  $E_1$  parallel to the plate and  $E_2$  perpendicular to  $E_1$  as shown in figure 5.12 (b). After propagation through the plate these components are given by

$$\begin{aligned}
 E_1 &= (E_0 \cos 45^\circ) e^{-j\beta_1 l} = E_0 e^{-j\beta_1 l} \\
 E_2 &= (E_0 \sin 45^\circ) e^{-j\beta_2 l} = E_0 e^{-j\beta_2 l} \\
 \text{Where } E_0 &= \frac{E_i}{\sqrt{2}}
 \end{aligned}$$

The length  $l$  is adjusted such that these two components  $E_1$  and  $E_2$  have equal amplitude but differing in phase by  $= 90^\circ$ .

$$\begin{aligned}
 E_1 &= E_0 e^{-j\beta_1 l} \\
 E_2 &= E_0 e^{-j(\beta_1 l - 90^\circ)} = E_0 e^{-j(\beta_1 l - \frac{\pi}{2})} \\
 \therefore E_2 &= E_0 e^{-j\beta_1 l} e^{j\pi/2} \\
 \therefore E_2 &= E_1 e^{j\pi/2}
 \end{aligned}$$

The quarter wave sections convert a linearly polarized TELL wave into a circularly polarized wave and vice-versa. After emerging out of the half-wave section, the electric field components parallel and perpendicular to the half-wave plate are given by



$$\begin{aligned}
E_3 &= (E_1 \cos \theta - E_2 \sin \theta) e^{-j2\beta_1 l} \quad \text{referring to figure 5.12 (c)} \\
&= (E_1 \cos \theta - E_1 e^{j\pi/2} \sin \theta) e^{-j2\beta_1 l} \quad \text{by using equation (5.18)} \\
&= E_1 (\cos \theta - j \sin \theta) e^{-j2\beta_1 l} \quad [\text{since } e^{j\pi/2} = \cos \pi/2 + j \sin \pi/2 = j] \\
&= E_1 e^{-j\theta} e^{-j2\beta_1 l} \\
&= E_0 e^{-j\beta_1 l} e^{-j\theta} e^{-j2\beta_1 l} \quad \text{by using equation (5.17)} \\
\therefore E_3 &= E_0 e^{-j\theta} e^{-j3\beta_1 l} \quad \dots (5.19)
\end{aligned}$$

and

$$\begin{aligned}
E_4 &= (E_1 \sin \theta + E_2 \cos \theta) e^{-j2\beta_2 l} \\
&= (E_1 \sin \theta + E_1 e^{j\pi/2} \cos \theta) e^{-j2\beta_2 l} \quad \text{using equation (5.18)} \\
&= E_1 (\sin \theta + j \cos \theta) e^{-j2\beta_2 l} \\
&= j E_1 (\cos \theta - j \sin \theta) e^{-j2(\beta_1 l - \frac{\pi}{2})} \\
&= j E_1 e^{-j\theta} e^{-j2\pi\beta_1 l} e^{j\pi} \\
&= E_1 e^{-j\theta} e^{-j2\beta_1 l} e^{j\pi/2} e^{j\pi} \quad [\text{since } j = e^{j\pi/2}] \\
&= E_0 e^{-j\beta_1 l} e^{-j\theta} e^{-j2\beta_1 l} e^{j3\pi/2} \quad \text{by using equation (5.17)} \\
\therefore E_4 &= E_0 e^{-j\theta} e^{-j3\beta_1 l} e^{j3\pi/2} \quad \dots (5.20)
\end{aligned}$$

After emerging out of the half-wave section, the field components  $E_3$  and  $E_4$  as given by equations (5.19) and (5.20), may again be resolved into two TE11 modes, polarized parallel and perpendicular to the output quarterwave plate. At the output end of this quarterwave plate, the field components parallel and perpendicular to the quarter wave plate, by referring to figure 5.12 (d), can be expressed as

$$\begin{aligned}
E_5 &= (E_3 \cos \theta + E_4 \sin \theta) e^{-j\beta_1 l} \\
&= (E_0 e^{-j\theta} e^{-j3\beta_1 l} \cos \theta + E_0 e^{-j\theta} e^{-j3\beta_1 l} e^{j3\pi/2} \sin \theta) e^{-j\beta_1 l}
\end{aligned}$$

$$\begin{aligned}
&= E_0 (\cos\theta + e^{j3\pi/2} \sin\theta) e^{-j\theta} e^{-j3\beta_1 l} e^{-j\beta_1 l} \\
&= E_0 (\cos\theta - j \sin\theta) e^{-j\theta} e^{-4\beta_1 l} \\
\therefore E_5 &= E_0 e^{-j\theta} e^{-j\theta} e^{-j4\beta_1 l} \\
\therefore E_5 &= E_0 e^{-j2\theta} e^{-j4\beta_1 l} \quad \dots (5.21) \\
\text{and } E_6 &= (E_4 \cos\theta - E_3 \sin\theta) e^{-j\beta_2 l} \\
\therefore E_6 &= (E_0 e^{-j\theta} e^{-j3\beta_1 l} e^{j3\pi/2} \cos\theta - E_0 e^{-j\theta} e^{-j3\beta_1 l} \sin\theta) e^{-j\beta_2 l} \text{ by using equations} \\
&\quad (5.19) \text{ and } (5.20) \\
\therefore E_6 &= E_0 (e^{j3\pi/2} \cos\theta - \sin\theta) e^{-j\theta} e^{-j3\beta_1 l} e^{-j(\beta_1 l - \frac{\pi}{2})} \\
&= E_0 (-j \cos\theta - \sin\theta) e^{-j\theta} e^{-j3\beta_1 l} e^{-j\beta_1 l} e^{j\pi/2} \\
&= E_0 (-j) (\cos\theta - j \sin\theta) e^{-j\theta} e^{-j4\beta_1 l} e^{j\pi/2} \\
&= E_0 e^{j3\pi/2} e^{-j\theta} e^{-j\theta} e^{-j4\beta_1 l} e^{j\pi/2} \\
&= E_0 e^{-j2\theta} e^{-j4\beta_1 l} e^{j2\pi} \\
\text{since } e^{j2\pi} &= 1, \text{ we get} \\
E_6 &= E_0 e^{-j2\theta} e^{-j4\beta_1 l} \quad \dots (5.22)
\end{aligned}$$

Comparison of equation (5.21) and (5.22) yields that the components  $E_5$  and  $E_6$  are identical in both magnitude and phase and the resultant electric field strength at the output is given by

$$\begin{aligned}
E_{\text{out}} &= \sqrt{(E_5)^2 + (E_6)^2} \\
&= \sqrt{2} E_0 e^{-j2\theta} e^{-j4\beta_1 l}
\end{aligned}$$