

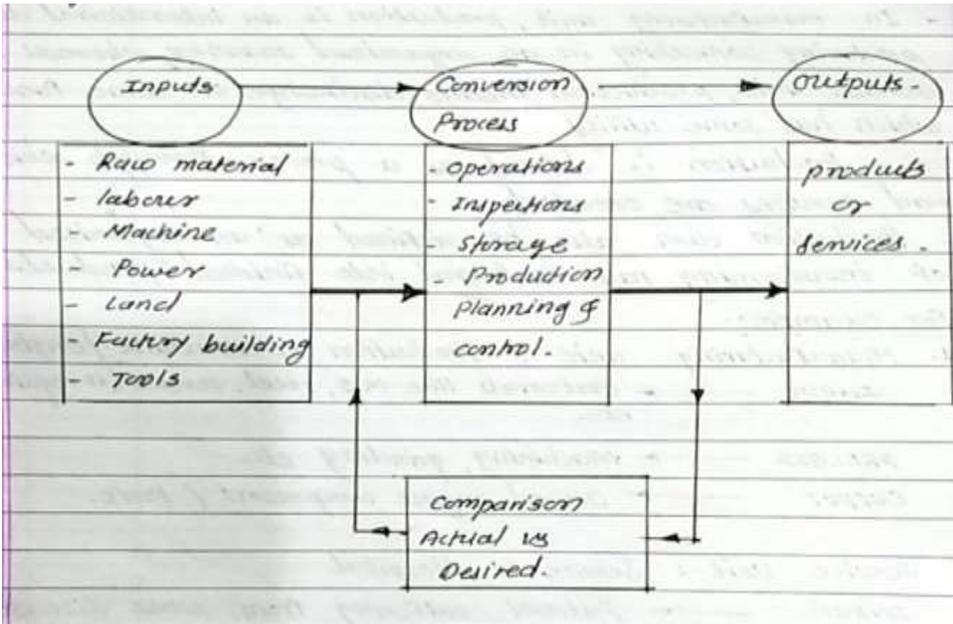

Important Instructions to examiners:

- 1) The answers should be examined by key words and not as word-to-word as given in the model answer scheme.
- 2) The model answer and the answer written by candidate may vary but the examiner may try to assess the understanding level of the candidate.
- 3) The language errors such as grammatical, spelling errors should not be given more Importance (Not applicable for subject English and Communication Skills).
- 4) While assessing figures, examiner may give credit for principal components indicated in the figure. The figures drawn by candidate and model answer may vary. The examiner may give credit for any equivalent figure drawn.
- 5) Credits may be given step wise for numerical problems. In some cases, the assumed constant values may vary and there may be some difference in the candidate's answers and model answer.
- 6) In case of some questions credit may be given by judgement on part of examiner of relevant answer based on candidate's understanding.
- 7) For programming language papers, credit may be given to any other program based on equivalent concept.

Q. No	Sub Q.	Answer	Marking Scheme
1.	a) (i) Explain production system with block diagram. Also give two examples. Ans :	<p>Attempt any THREE of the following:</p>  <ol style="list-style-type: none"> 1. The production system of an organization is that part, which produces product of an organization. 2. It is that activity whereby the resources, flowing within the definite system are combined and transformed in controlled manner to add value in accordance with the policies communicated by management. 3. Production system consists of input at one end and output at other. 	<p>12</p> <p>Block diagram – 2 marks.</p> <p>Explanation – 1 mark.</p> <p>Examples – 1 marks.</p>



		<p>4. The input and output are connected by series of operations or processes, stages and inspections.</p> <p>5. Simple Input-Process-Output model of production system is shown in following diagram.</p> <p>For Example:</p> <p>1. Manufacturing unit: Production of machine or engine component. INPUT – Material like M.S, Steel, Screws (if required), machines etc. PROCESS – Machining, Grinding etc. OUTPUT – Desired engine component.</p> <p>2. Service unit: Service provided in hospital. INPUT – Patient suffering from some disease. PROCESS – Medical checkup and treatment. OUTPUT – Healthy or cured patient.</p>	
(ii) Ans :		<p>Compare production and productivity with suitable example.</p> <p>Following points differentiates production from productivity.</p> <ol style="list-style-type: none">1. Production is step by step transformation process of inputs into outputs having desired utility and quality whereas productivity is defined as human effort to produce more and more with less and less inputs of resources.2. Production refers to absolute output whereas productivity is a relative term where the output is always expressed in terms of inputs.3. Production is value addition process while productivity is efficiency of production system.4. The production may rise without the corresponding rise in productivity and vice versa i.e. increase in production may or may not be an indicator of increase in productivity and vice versa. <p>Example: Let us assume that a scooter manufacturing company was producing 500 vehicles per day. Its output is increased to 600 vehicles per day. Then the production of the company is increased. But this is not assured that the productivity is increased. This is because the productivity takes into account the increase in inputs to achieve this increase in output.</p> <p>In the above example the productivity will be increased if increase in no.of vehicles (from 500 to 600 vehicles per day) is achieved without increasing the inputs or with little increase in inputs. If the output rises at slower rate than the input, there will be fall in the productivity even though there is rise in production.</p>	<p>Two points of comparison – 2 marks.</p> <p>Example with proper explanation – 2 marks.</p>



(iii)	Explain any four techniques to improve the productivity of manufacturing firm.	1 M for each point.
Ans	Technique for improving Productivity	(Any four points)
:	<p>a) Work Study: - Work study aims two objectives one is to find out the best method of doing job and another one is to find the time taken to do it. This is done by breaking down the job into it various elements, eliminating all unnecessary movements and estimating the time taken to do this job with the help of stopwatch. Second aim is to ensure that all workers engaged in the job are trained to do it in the best way.</p> <p>b) Human Relations: - Good human relations help in co-operative behavior from workers which results in increase in productivity. Human relations can be improved by labour participation in goal setting, simplification in communication system minimizing the conflicts, encouragement and awarding rewards etc</p> <p>c) Incentives: - When incentives schemes are introduced in a firm, it results a considerable improvement in productivity. It is something that encouraged a worker to put in more productivity effort. Works will not give 100% unless their interest in work is created by some kind of reward.</p> <p>d) Cost Control: - Productivity can be increased by reducing the cost of production. This can be done by keeping careful watch over expenditure, reduction in wastage, reducing machine breakdown time, reducing waiting time for inventory avoiding excessive handling, minimizing overtime expenses etc.</p> <p>e) Product design: - A good design of product helps in economical and convenient manufacturing. It will also minimize wastage or scrap and reduce the cost of production. In order to achieve high productivity, product design must be simple to understand, standardization and simplification increases the production efficiency, research and development contributes improvement in product design, product development reduces ineffective time due to change in design, design must considered the current the current available technology.</p> <p>f) Working Conditions or ergonomics: - It is nothing but the design the man machine system in such a way that to ensure high productivity and safety of workers. Working conditions like lighting, ventilation, working hours, supervision etc definitely affects the productivity. Also water facility, sitting room, bathroom, and toilets in sufficient numbers are considered to maintain working conditions. To motivate workers' productivity related statement are displayed in a firm such that workers can read it frequently.</p> <p>g) Management by objectives:- It is process where the superior and subordinate management jointly identify common goal and define individual responsibility in terms of results expected from him</p> <p>h) Total Quality Management: - By this it obtained the greater customer satisfaction, fewer defects and less waste improved profitability and increased productivity.</p>	

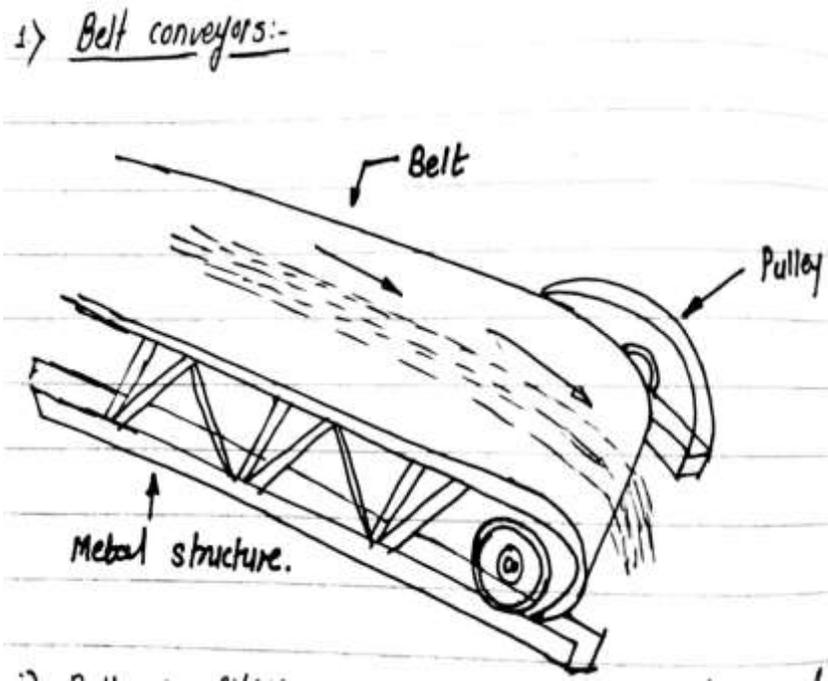

(iv)	State the objectives of production planning and control.	Any eight
Ans	<p>Objectives of production planning and control.</p> <ol style="list-style-type: none">1. Implementation of production plan in the right spirit, i.e. considering quality, quantity, time and cost.2. Optimum utilization of resources so as to reduce the cost of production to a minimum.3. To provide inspection and quality control techniques so as to keep the desired level of the product.4. To produce a product in economic lot size so as to reduce the set up time.5. To supply raw materials, tools, jigs and fixtures in time so as to avoid loss of man and machine hour.6. To apply budgetary control over production process.7. To avoid waste or to at least keep within the limits.8. To control sequence of operation.9. To prepare the master schedule of production.10. To keep the production efficiency at its highest level.	points – 4 M. (consider related points also other than these points)

<p>b)</p> <p>(i)</p> <p>Ans :</p>	<p>Suggest and explain with neat sketch material handling device used in process production.</p> <p>Conveyors are used in process production due to requirement of continues movement of material. Conveyors are of following type</p> <ol style="list-style-type: none"> Belt conveyer. Roller conveyer. Chain Conveyer. Screw conveyer. <p>Belt Conveyor:</p> <ol style="list-style-type: none"> Belt conveyers are particularly suitable for package handling because of their smooth, noiseless operation. It can be used for handling of materials in horizontal or inclined direction. Belt conveyer consists of an endless belt, idler roller, structure, a head pulley, a tail pulley and suitable drive. The width of belt ranges from 8 cm to 100 cm. and material of belt can be rubber, plastic, leather, sometimes flat steel bands can also be used. Speed of belt normally ranges from 1 m/s to 70 m/s. <p>1) <u>Belt conveyors:-</u></p> 	<p>06</p> <p>Any one device name – 1 mark</p> <p>(Also consider proper device other than this)</p> <p>Sketch – 2 marks.</p> <p>Explanation – 3 marks.</p>
<p>(ii)</p> <p>Ans :</p>	<p>Explain Gantt chart used in scheduling with suitable example.</p> <p>Gantt Chart:</p> <ol style="list-style-type: none"> The Gantt chart is actually modified bar chart in which horizontal bars are drawn for each activity in proportion to the time required for completing it. 	<p>Explanation – 4 M.</p> <p>Sketch – 2 M.</p>



2. It is frequently used to keep track of multiple machine schedules.
3. This chart provides an immediate comparison between schedule and reality (i.e. planned work and actual progress of work.)
4. This is achieved simply by marking the planned work and the actual progress of work on the chart.
5. A cursor attached to Gantt chart can be moved across the chart to compare between the actual progress and planned work till any particular date.
6. An example of typical Gantt chart is shown in following figure in which various departments or sections of the industry shown at one side and comparison of actual and planned work shown in front of respective department or section.

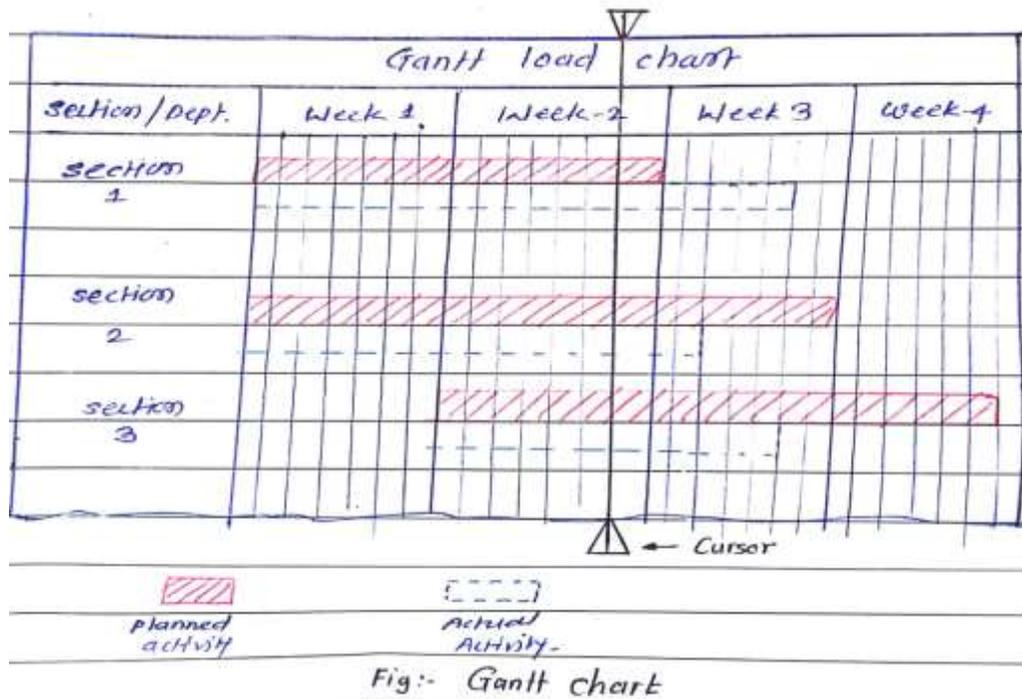

2.

Attempt any TWO of the following:

16

a) **Prepare operation process sheet and sequence of operation by taking suitable example. Assume suitable cutting parameter**

Ans :

Example: Prepare operation process sheet and sequence of operation for the Ring nut shown in figure. Assume suitable cutting parameter and raw material $\phi 50 \times 10$ mm blank of carbon steel.

Proper example statement – 1 mark.

Layout of operation sheet – 2 marks.

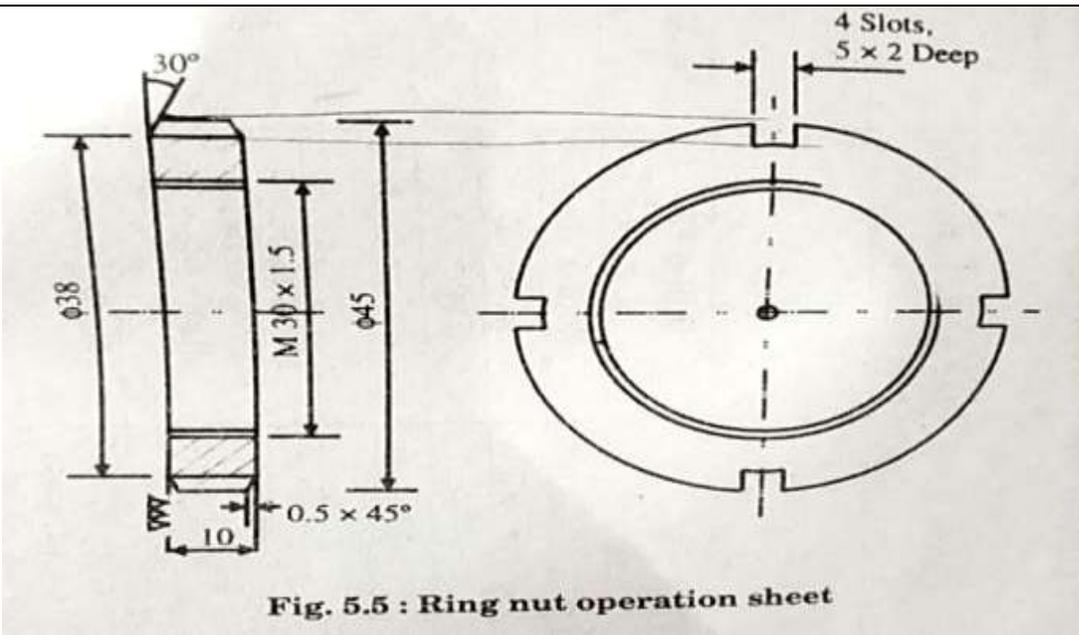

Operations and proper sequence of operation – 3 marks.

Suitable cutting parameter assumptions – 2 marks.

Part Name: Ring Nut				Material: Carbon steel		
Part no: mm, blank				Material Size: Φ 50×10		
Opn no	Description of operation	Machine used	Tools /Fixtures used	Feed mm/rev	Cutting speed m/min	Depth of cut mm
01	Clamp the blank in chuck and face one side	Centre lathe no...	H.S.S.,R.H. Turning tool	0.0025	30	-
02	Reverse the blank in the chuck and face other side (Made Width =7.5)	-----"-----	-----"-----	0.025	30	-
03	Drill hole , Φ 27 by fitting drill in tail stock spindle	-----"-----	Drill Φ 27	Medium	30	-
04	Internal threading m 30×1.5	-----"-----	Boring bar		6	-
05	Turn Φ 45	-----"-----	Mandrel	0.025	30	1.0
06	Chamfer 0.5×45°	-----"-----	R.H.Tool	0.025	30	-



07	Reverse the job and chamfer 3.5×30°	-----”-----	-----”-----	0.025	30	-
08	Mill slot (4 no.) 5×2 Deep	Horizontal Milling machine No.....	Mandrel ,side Milling Cutter of 5 mm width	07/ Tooth	25	3
09	Grinding one side	Cylindrical Grinding Machine No	Indexing head	-	100	0.05

b) Sketch the following layout types.

Ans :
:

(i) Line layout

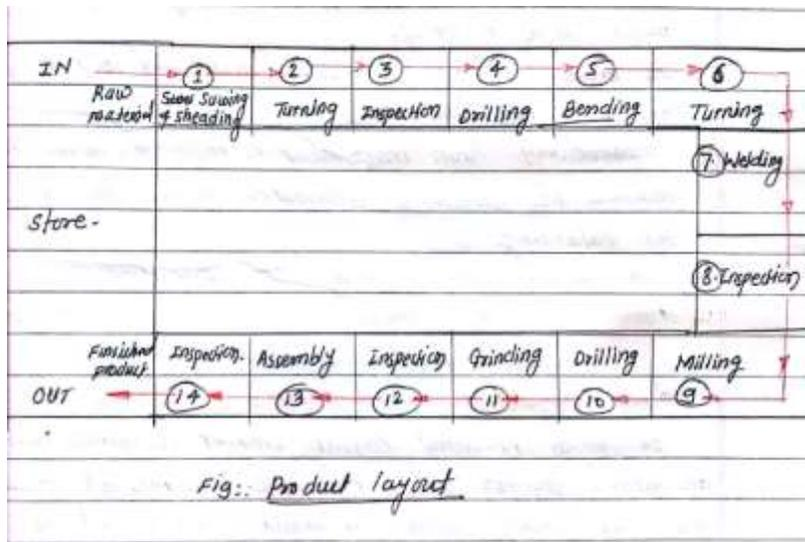

(ii) Functional layout

Each Layout – 2 marks.

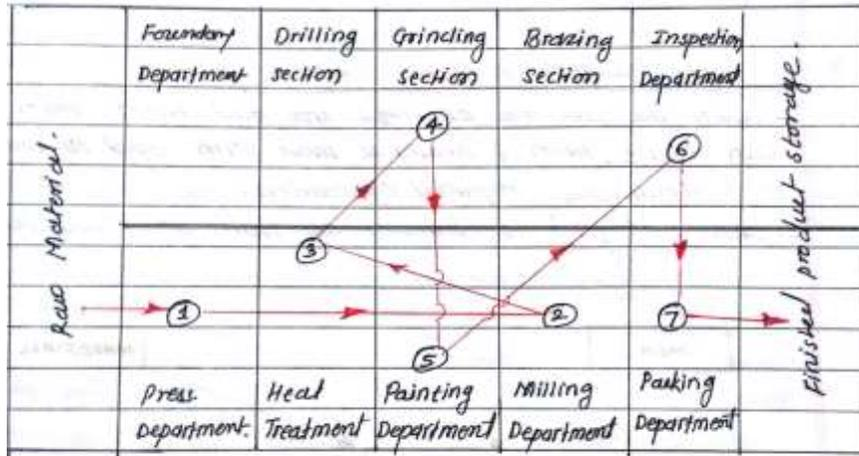
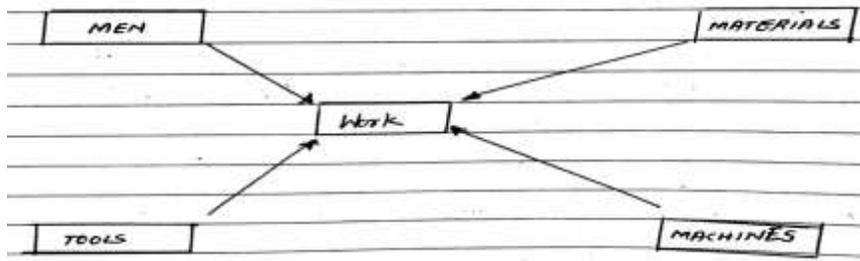
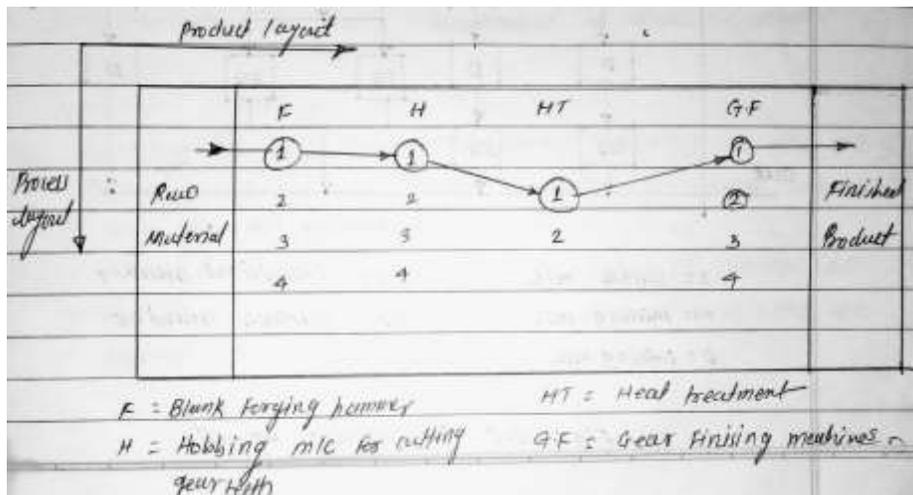

Fig: A typical process layout-

(iii) Fixed position layout



(iv) Combined layout





	c) Ans	<p>Write stepwise procedure of process planning from raw material to finished product.</p> <p>Steps involved in process planning:</p> <p>1. Analysis of Product and its specification: - During analysis, following parameter should be considered,</p> <ul style="list-style-type: none">a. Drawing and specification of product.b. Quality of product.c. Number of parts/components per product. <p>2. Make or buy decision: Process planning determines what parts are to be manufactured in the firm itself and what parts are to be purchased from outside.</p> <p>3. Selection of basic manufacturing process: Once the decision is taken what parts to be manufactured, next step is to decide the manufacturing process. The alternative methods are compared and most practical and economical method is decided by calculating and comparing total cost for two or more feasible method.</p> <p>4. Determining sequence of operation: Once the best manufacturing process is selected, sequence of operation to be performed on each component is determined.</p> <p>5. Combine the operations: If possible practically, combine as many operations as possible. As it is economical to combine the operations.</p> <p>6. Selection of machine tools/equipments: Selection of correct machine is closely related to the process of manufacture. While selecting the machine, following factors should be considered:</p> <ul style="list-style-type: none">a. Size and form of work piece.b. Accuracy and surface finish required.c. Quantity required. <p>7. Inspection: At this stage, inspection devices and stages are decided.</p> <p>8. Requirement of tools, gauges etc.: To determine and order the tools and gauges required to manufacture the part.</p> <p>9. Labour requirement: Kind/Skill of labour required to do the job.</p> <p>10. Time standards: To determine the time standards for performance of the job and fixing the rates of payment.</p> <p>11. Prepare the route sheet and operation sheet</p>	Any 8 steps with logical sequence – 8 marks (1 mark for each step)
3.	a) Ans	<p>Attempt any FOUR of the following:</p> <p>Classify material handling devices.</p> <p>Types of material handling devices</p> <p>1.Trucks :</p> <p>i) Power lift :</p>	12 1 Mark for each point, total 4M.



	<p>a. Fork lift b. elevating platform</p> <p>ii) Hand Lift. iii) Porters trolley.</p> <p>2.Tractors and trailers</p> <p>3. Hoist and cranes:</p> <p>i) Hoist</p> <p>a. Chain hoist. b. Electric hoist.</p> <p>ii) Crane –</p> <p>a. Over bridge crane b. Jib crane.</p> <p>4.Conveyers :</p> <p>a. Belt conveyer. b. Roller conveyer. c. Chain Conveyer. d. Screw conveyer.</p> <p>5. Automated guided vehicle.</p>	
b) Ans :	<p>How operations are combined? Explain with example.</p> <p>Combined Operation:</p> <ol style="list-style-type: none">1. In order to save the operation and setting time of part, while the part is subjected to machining process, the different operations to be performed are combined together or arranged one after the other, during one setting of the part.2. This combination process helps not only in saving the setting time but also the accuracy of the operation.3. The operations can be combined in two ways<ol style="list-style-type: none">I. Simulation method: Operations combined together and performed simultaneously.II. Integration method: Operations to be performed combined together in one setting but arranged one after other. <p>Examples:</p> <ol style="list-style-type: none">1. Simulation Method: Gang milling operations, Straddle milling operation, slot making operations on CNC machining centers etc.2. Integration Method: Operation on turret lathe, multi spindle automats, CNC operations etc.	<p>Explanation - 2 marks.</p> <p>Example – 2 marks.</p>
c) Ans :	<p>State the factors affecting site selection for manufacturing industry.</p> <p>Factors affecting selection of site for new industry/plant:</p>	<p>Any four point – 4 marks.</p>



	<ol style="list-style-type: none">1. Availability of raw material: As far as possible the site selected should be near the source of raw materials so that cost of transportation can be minimized and storing cost can be reduced especially when the raw material is heavy and bulky or cheap but loses a good amount of weight during processing. For example most of the iron and steel industries are situated in Orissa and Bihar, Paper industries in Ballarpur due to availability of raw material in these areas.2. Availability of labour: Available of right kind of labour in required numbers of reasonable rates is also deciding factor in site selection. Unskilled labours are amply available at major industrial areas and rural areas but however firms requiring skilled labour be situated near the urban industrial area.3. Climatic condition: Climatic conditions largely affect certain production processes and also the efficiency of employees. For example textile industries required moist climate due to which these types of industries are situated near Ahmadabad and Mumbai; similarly Tea and Coffee near Assam.4. Proximity of market: Market is another important factor affecting site selection. Industrial units using raw material should be located near the markets to serve the customer with minimum service cost.5. Transport and communication facilities: While selecting the site, adequate transportation facilities should be considered. The optimum site is the site which is well connected by various modes of transportation.6. Availability of water: Water is required for drinking and sanitary purpose of all industries. Therefore, clean and adequate water should be available near the site.7. Availability of power and fuel: All industries require power and fuel to run the prime movers. Therefore, the site selected should have these facilities available at cheaper rate.8. Legal Aspects: Local bye laws, taxes etc. are also important because they directly reflect in total cost. So while selection, it should also consider legal aspects.9. Amenities and recreational facilities: Facilities like schools, hospitals, garden, and play grounds should also be needed for employee and their family.10. Scope of Future expansion: Site selected should be in such a way that a plenty of land other facilities must be available for future expansion.11. Community attitude : Mindset of the local people is also important, many times they oppose the work.	
d)	Explain the concept of ERP. 1. Enterprise resource planning (ERP) is a process by which a company (often a manufacturer) manages and integrates the important parts of its business. An ERP management information system	Concept – 2 marks.



Ans :	<p>integrates areas such as planning, purchasing, inventory, sales, marketing, finance and human resources.</p> <p>2. It integrates all departments and functions across a company in a single computer system that is able to serve all those different department's particular needs. An ERP system also automates business processes by placing them into a useful format that is standardized and common for the whole organization.</p> <p>3. ERP systems increase productivity. Because an ERP system integrates data and processes across multiple departments and locations, it allows a company to move product faster, process orders quicker, invoice customers more rapidly and reconcile shipments sooner.</p> <p>4. Advantages of ERP</p> <ol style="list-style-type: none">i. Improving internal business processes.ii. Improving company performance.iii. Reducing IT expenses and labor costs.iv. Improving interactions between internal employees and external organizations	Explanation – 2 marks.
e) Ans :	<p>Define jig and fixture. Give two examples of each.</p> <p>Definition of jig: It is a device which holds and locates work piece and guides and control one or more cutting tools.</p> <p>Examples:</p> <ol style="list-style-type: none">1. Template jig.2. Plate type jig.3. Diameter jig.4. Leaf jig.5. Channel type jig6. Clamp jig. <p>Definition of Fixture: It is a device which only holds and locates a work piece during an inspection or for a manufacturing operation.</p> <p>Examples:</p> <ol style="list-style-type: none">1. Indexing fixture.2. Milling Fixture3. Milling Machine vice fixture4. Straddle milling fixture.	Definition of jig – 1 mark. Definition of fixture – 1 mark. Two examples of each – 2 marks.
f) Ans :	<p>Why allowances are considered while calculating standard time? Explain.</p> <p>We know that, $\text{Standard time} = \text{Normal time} + \text{Allowances}$</p> <p>Allowances are considered while calculating standard time because;</p> <ul style="list-style-type: none">- Method study investigation tries to minimize the energy expended by the worker in performing the operation.- However, the job will still require the expenditure of human effort.- Therefore, a worker is not able to work throughout the day continuously. Therefore he requires sometime for recovery from fatigue and for relaxation.	Proper explanation – 4 marks.



- He also requires some additional time for his personal needs and other reasons.
- This additional time other than basic time is known as allowance.

4

a) Sketch any two drill jig bushes

Ans

Figure:- Headed Drill Jig Bushes

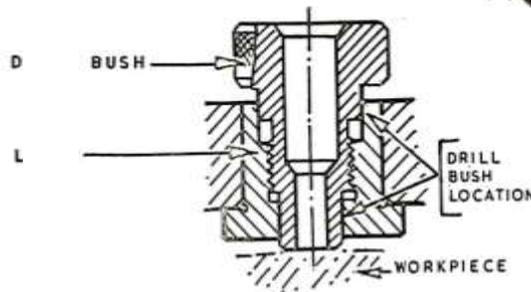
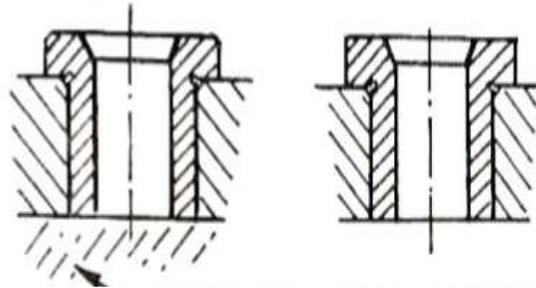
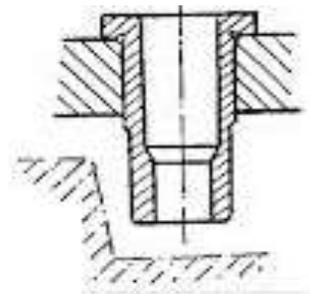
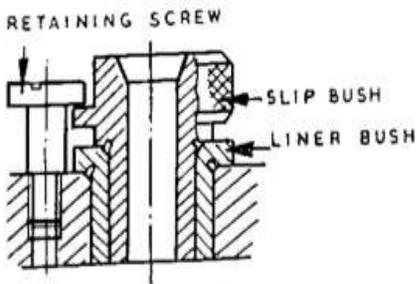

Figure:- Threaded Bush



ii)

Ans How '5S' can be used as inventory reduction technique

5's can be use as a inventory management technique as it has the main objectives to manage the inventory level.

Its objectives are,

- [1] It keeps the inventory at needed level only.
- [2] It Keeps the workplace in order and cleans.
- [3] It aims to eliminate unwanted items.

2 Marks each for any 2 correct sketches



		SEIRI in 5's refers to the removal of unrelated material from the work place which reduces unwanted material inventory. SEIKETSU refers to the standardization of work being done which eliminate the wasteful work and material results into reduction of inventory. With all these above objectives and main function of 5's it can be used for the inventory reduction or inventory management	4 Marks
	iii)	State the applications of robots	
	Ans	[1] Material Handling [2] Welding [3] Painting [4] Medical applications [5] Service applications [6] Military applications [7] space applications	1 Mark each for any 4 correct applications
	iv)	Give the classification of sensors used in robots	
	Ans	Classification of Robot Sensor: Robot Sensors senses and capability includes vision and hand eye coordination, touch, hearing, sensors will divided into the following categories. [1] Vision Sensor: [2] Tactile Sensor: 2.1 Touch Sensor 2.2 Stress Sensor [3] Proximity Sensor: [4] Voice Sensor:	1 Mark each for any 4 correct points
	b)	Attempt any ONE of the following	
	i)	Describe 3-2-1 principle of location with neat sketch	
	Ans	3-2-1 Principle of Location used in Jig & Fixtures: [1] It is also known as six pin or six point location principle. In this, the three adjacent locating surfaces of the blank (work piece) are resting against 3, 2 and 1 pins respectively, which prevent 9 degrees of freedom.	4 Marks for explanation and



[2] The rest three degrees of freedom are arrested by three external forces usually provided directly by clamping.

The **3-2-1 principle** states that the six locators are sufficient to restrict the required degree of freedom of any work piece. In this, motion is restricted using clamps and locators. A three pin base can restrict five motions and six pins restrict nine motions.

Methodology of 3-2-1 Principle: For this, refer the below figure;

[1] The work piece is resting on three pins A, B and C which are inserted in the base of the fixed body.

[2] The work piece cannot rotate about the axes XX and YY and also cannot move downward.

[3] In this way, the **five degrees of freedom** 1,2,3,4 and 5 have been arrested.

[4] Two pins D and E are inserted in the fixed body, in a plane perpendicular to the plane containing pins A, B & C.

[5] Now the work piece cannot rotate about the Z axis and also it cannot move towards the left.

[6] Hence the addition of pins D and E restrict three more degrees of freedom, namely 6, 7 and 8.

[7] Another pin F in the second vertical face of the fixed body, arrests **degree of freedom 9**.

The above method of locating a work piece in a fixture is called the **3-2-1 Principle**.

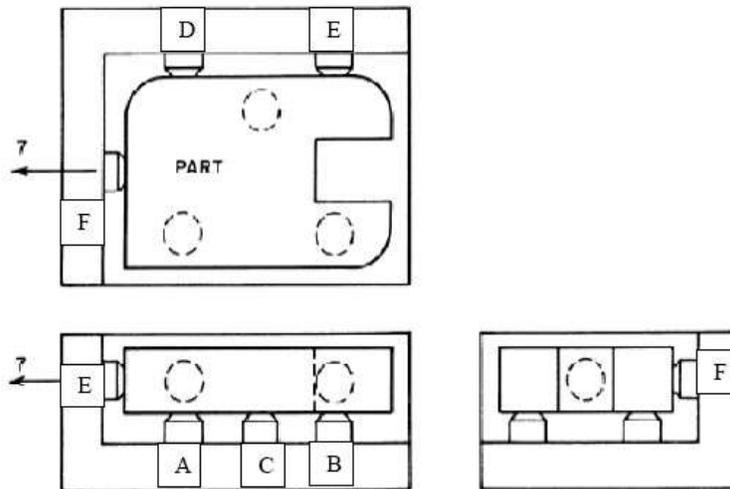

2 marks for diagram

ii)

A shop floor activity consists of three element. Find the standard time for the activity. The allowances are given as % of basic time

Elements	Observed Time (min)	Rating	Allowance
I	1	100	20%
II	2	110	15%
III	3	120	10%

Ans

2 Marks for Normal Time calculation



Elements	Observed Time (min)	Rating	Basic Time (Normal Time)
I	1	100	= 1 X (100/100) = 1
II	2	110	= 2 X (110/100) = 2.2
III	3	120	= 3 X (120/100) = 3.6

Total Normal Time = 1 + 2.2 + 3.6 = 6.8 min

Allowances :- % Allowance X Normal Time

For I, = (20/100) X 1 = 0.2 min

For II, = (15/100) X 2.2 = 0.33 min

For III, = (10/100) X 3.6 = 0.36 min

Standard Time = Normal Time + Allowances

Standard Time for I = 1 + 0.2 = 1.2 Min

Standard Time for II = 2.2 + 0.33 = 2.53 Min

Standard Time for III = 3.6 + 0.36 = 3.96 Min

2 Marks for Allowance Calculation

2 Marks for Standard time Calculation

5 Attempt any FOUR of the following

a) Draw a neat sketch of open type jig and label it.

Ans

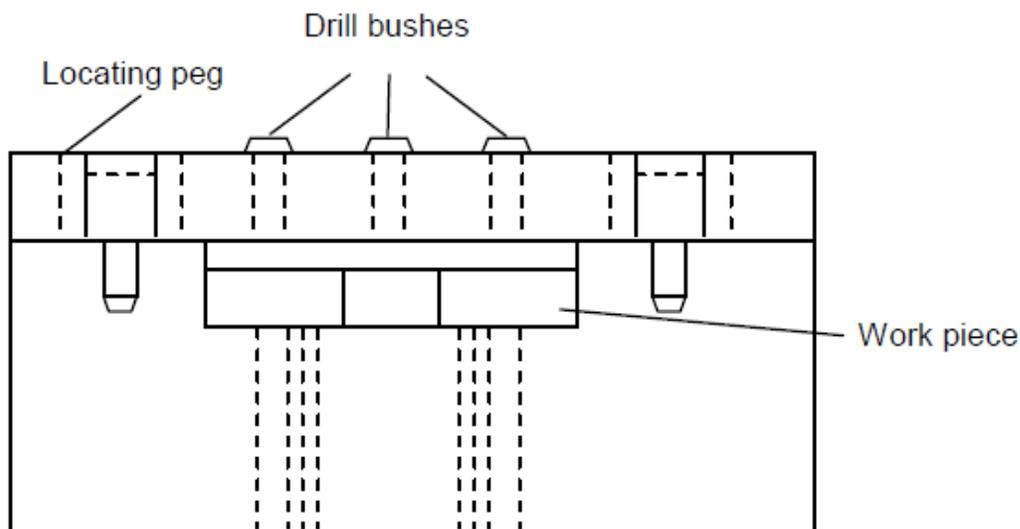

3 Marks for correct sketch and 1 Mark for Labeling

b) State the general principles of jigs and fixtures design

Ans

1 Mark each for



	<ol style="list-style-type: none"> 1. Before planning the design of a tool, compare the cost of production of the work with present tools with the expected cost of production, using the tool to be made. Confirm that the cost of building jigs & fixture is not in excess of expected gain. 2. Before lying out the jigs & fixture decide upon the location point & outline a clamping arrangement. 3. Make all clamping & building devices as quick acting as possible. 4. In selecting the location points, see that two component part of a machine can be located from corresponding points & surfaces. 5. Make the jig 'fool-proof' that means design it in such way that work cannot be inserted except in the correct way. 6. For rough casting, make some of the locating points adjustable. 7. Locate clamps so that they will be in the best position to resist the pressure of cutting tool when at work. 8. Wherever possible make all clamps, integral parts of jig or fixture. 9. Avoid complicated clamping arrangements which are liable to wear or get out of order 10. Place or clamps as nearly as possible opposite to some bearing point of the work to avoid springing. 11. Round all corners. 	<p>any 4 correct Points</p>															
<p>c) Ans</p>	<p>State the benefits and limitations of JIT</p> <p>Benefits</p> <ol style="list-style-type: none"> [1] To reduce inventory level [2] To eliminate unwanted costs associated with inventory [3] To satisfy customer requirement [4] To ensure production flow [5] To optimize lead time <p>Limitations</p> <ol style="list-style-type: none"> [1] Difficult to implement [2] Huge production loss in case of JIT failure [3] Complexity in maintenance [4] Lack of control over time frame [5] More planning required 	<p>½ Mark each for any 4 correct points</p> <p>½ Mark each for any 4 correct points</p>															
<p>d) Ans</p>	<p>Differentiate between hydraulic actuator and pneumatic actuator</p> <table border="1" data-bbox="203 1654 1386 1940"> <thead> <tr> <th>Sr. No.</th> <th>Hydraulic Actuator</th> <th>Pneumatic Actuator</th> </tr> </thead> <tbody> <tr> <td>1</td> <td>They are used to carry heavy loads</td> <td>They are used to carry lighter loads</td> </tr> <tr> <td>2</td> <td>They are more efficient</td> <td>They are less efficient</td> </tr> <tr> <td>3</td> <td>Maintenance cost is high</td> <td>Maintenance cost is low</td> </tr> <tr> <td>4</td> <td>Delivers better performance</td> <td>Comparatively poor performance</td> </tr> </tbody> </table>	Sr. No.	Hydraulic Actuator	Pneumatic Actuator	1	They are used to carry heavy loads	They are used to carry lighter loads	2	They are more efficient	They are less efficient	3	Maintenance cost is high	Maintenance cost is low	4	Delivers better performance	Comparatively poor performance	<p>1 Mark each for any 4</p>
Sr. No.	Hydraulic Actuator	Pneumatic Actuator															
1	They are used to carry heavy loads	They are used to carry lighter loads															
2	They are more efficient	They are less efficient															
3	Maintenance cost is high	Maintenance cost is low															
4	Delivers better performance	Comparatively poor performance															



		<p>5 They utilize fluid i.e. oil for actuation</p> <p>6 Requires more floor space</p> <p>7 More Expensive</p> <p>8 They are employed where speed requirement is comparatively low</p>	<p>They utilize air for actuation</p> <p>Require less floor space</p> <p>Less Expensive</p> <p>They are employed where fast cycles are required</p>	correct points
e)	<p>State four types of grippers used in robots with application of each</p> <p>Ans [1] Mechanical Grippers :- Pick and place operation</p> <p>[2] Vacuum Actuated Grippers :- Flat as well as curved surfaces, Automobile industries</p> <p>[3] Magnetic Grippers :- Automobile industries, For grasping Ferrous materials</p> <p>[4] Adhesive Grippers :- Fabrics and light weight materials</p> <p>[5] Special purpose Grippers:- Customized applications, hooking devices</p>			<p>½ Mark each for any 4 correct types and</p> <p>½ Mark each for any 4 correct applications</p>
f)	<p>Write down basic step in method study</p> <p>Ans</p> <pre> graph TD A[Select the task] --> B[Record all the facts] B --> C[Examine] C --> D[Develop] D --> E[Install] E --> F[Maintain] </pre> <p>{ Bottleneck/Repetitive task/ more labor/overtime }</p> <p>{ All facts related to existing method }</p> <p>{ Examine the facts critically but impartially }</p> <p>{ Most economical method satisfying firms requirement }</p> <p>{ Implement new method as standard practice }</p> <p>{ Maintain the new method / Evaluation }</p>			4 Marks for correct steps
6	<p>Attempt any TWO of the following</p>			
a)	<p>Describe the types of scheduling in details</p> <p>Ans Schedules are of Two Types</p> <p>[1] Master schedule</p> <p>[2] Shop or production schedule</p>			4 Marks



	<p>[1] Master Schedule: - Scheduling usually begins with the master schedule. It represents the master plan of manufacturing in a given period of time. Master schedule to stock begins with a sales forecast. Function of master schedule is to minimize the difference between regular sales and steady production. Nature of master schedule depends upon whether the product is produced according to order or to stock. Master Production Scheduling (MPS), otherwise known as an over-all schedule, focuses on a planning horizon, divided into equal time periods (time buckets, such as by month). It includes a plan for the production of individual commodities such as staffing, inventory, etc for the allotted time period. A MPS usually dictates when and how much of each product is going to be produced, based on criteria such as demand, capacity, and inventory availability. MPS aids in decision making by generating a set of output data based on forecast demand, production costs, inventory money, customer needs, production lead time, and capacity. The resulting output information includes the amounts to produce, staffing requirements, quantity of product available to promise, and projected available funds for production. It also sets the expectations of the revenue that the business is likely to generate.</p> <p>[2] Shop or Production schedule :-</p> <p>Total number of products to be manufactured. Number of assemblies or sub-assemblies requires. Manpower and machine requirements are decided during this scheduling. This type of scheduling may be done for a month or quarter or yearly.</p> <p>[a] Long-term Scheduling</p> <p>Long term scheduling is performed when a new process is created. The long-term scheduler limits the number of processes to allow for processing by taking the decision to add one or more new jobs, based on FCFS (First-Come, first-serve) basis or priority or execution time or Input/Output requirements. Long-term scheduler executes relatively infrequently.</p> <p>[b] Medium-term Scheduling</p> <p>Medium-term scheduling is a part of the swapping function. This scheduler works in close conjunction with the long-term scheduler. It will perform the swapping-in function among the swapped-out processes. Medium-term scheduler executes some what more frequently.</p> <p>[c] Short-term Scheduling</p> <p>Short-term scheduler is also called as dispatcher. Short-term scheduler is involved whenever an event occurs, that may lead to the interruption of the current running process. Short-term scheduler executes most frequently.</p>	4 Marks
b) Ans	Prepare a two handed process chart for a task of sharpening the pencil with appropriate process chart symbol ➤ Task :- Assembly of Nut and Bolt	



- Chart begins :- Both hands free before task
- Chart ends :- Both hands free after task
- Charted by :- -----
- Date of Charting :- -----

Left Hand		Right Hand	
Description	Symbol	Symbol	Description
Pick the pencil			Delayed / Wait
Hold			Pick the sharpener
Insert the pencil in sharpener			Hold
Rotate the pencil			Hold
Check for Sharpness			Delayed / Wait
Place the pencil			Place the Sharpener

Summary

Symbol					
Frequency (L.H.)	2	2	1	1	0
Frequency (R. H.)	0	2	0	2	2

1 Mark for chart heading

6 Marks for Logical sequence and correct symbols

1 Mark for summary

c) Describe the robot configurations with neat sketch

Ans Robot Configurations:-

- 1) **Rectangular Configuration:-** This uses three perpendicular slides to construct the x, y, z axes. By moving three slides relative to one another, the robot is capable of operating within a rectangular work envelope. These are also called as Cartesian configuration robots.
- 2) **Cylindrical Configuration:-** These uses a vertical column and a slide that can be moved up and down along the column. The robot arm is attached to the slide so that it can be moved radially with respect to the column. By rotating the column the robot is capable of retrieving a cylindrical work envelope.
- 3) **Spherical Configuration:-** IT uses telescopic arm that can be raised or lowered about a horizontal pivot point. The pivot point is mounted on a rotating base and gives the robot its vertical movement. These various joints provide the robot with the ability to move its arm within a spherical envelope.
- 4) **Jointed arm Configuration:-** It consists of two straight components whose shoulders and elbow joints rotate about horizontal axes corresponding to the human forearm and upper arm. Its work envelope is of irregular shape.
- 5) **SCARA Configuration:-** It is a special version of the jointed arm robot whose shoulder and elbow joints rotate about the vertical axes instead of horizontal. Its work envelope is cylindrical and much larger than all other configurations, which provides a substantial rigidity in the vertical direction for many essential tasks.

1Mark each for any 4 correct points

1Mark each for 4

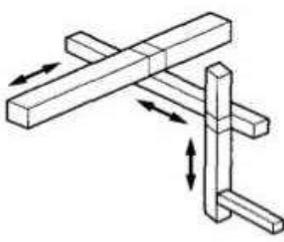
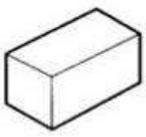
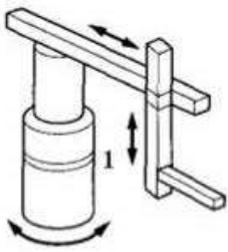
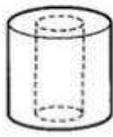
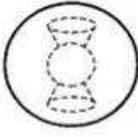
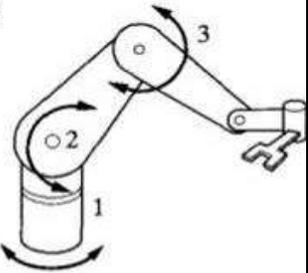
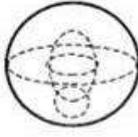

		 <p>Cartesian</p> 	 <p>Cylindrical</p> 	 <p>Spherical</p> 	 <p>Articulated</p> 	<p>correct diagram / Sketch</p>
--	--	--	--	--	--	---