

MATHEMATICS

Exemplar Problems

Class X

MATHEMATICS
EXEMPLAR PROBLEMS

Class X

राष्ट्रीय शैक्षिक अनुसंधान और प्रशिक्षण परिषद्
NATIONAL COUNCIL OF EDUCATIONAL RESEARCH AND TRAINING

FOREWORD

The National Curriculum Framework (NCF) – 2005 initiated a new phase of development of syllabi and textbooks for all stages of school education. Conscious effort has been made to discourage rote learning and to diffuse sharp boundaries between different subject areas. This is well in tune with the NPE – 1986 and *Learning Without Burden-1993* that recommend child centred system of education. The textbooks for Classes IX and XI were released in 2006 and for Classes X and XII in 2007. Overall the books have been well received by students and teachers.

NCF–2005 notes that treating the prescribed textbooks as the sole basis of examination is one of the key reasons why other resources and sites of learning are ignored. It further reiterates that the methods used for teaching and evaluation will also determine how effective these textbooks proves for making children’s life at school a happy experience, rather than source of stress or boredom. It calls for reform in examination system currently prevailing in the country.

The position papers of the National Focus Groups on *Teaching of Science, Teaching of Mathematics and Examination Reform* envisage that the mathematics question papers, set in annual examinations conducted by the various Boards do not really assess genuine understanding of the subjects. The quality of question papers is often not up to the mark. They usually seek mere information based on rote memorization, and fail to test higher-order skills like reasoning and analysis, let alone lateral thinking, creativity, and judgment. Good unconventional questions, challenging problems and experiment-based problems rarely find a place in question papers. In order to address to the issue, and also to provide additional learning material, the Department of Education in Science and Mathematics (DESM) has made an attempt to develop resource book of exemplar problems in different subjects at secondary and higher-secondary stages. Each resource book contains different types of questions of varying difficulty level. Some questions would require the students to apply simultaneously understanding of more than one chapters/units. These problems are *not* meant to serve merely as question bank for examinations but are primarily meant to improve the quality of teaching/learning process in schools. It is expected that these problems would encourage teachers to design quality questions on their own. Students and teachers should always keep in mind that examination and assessment should test

comprehension, information recall, analytical thinking and problem-solving ability, creativity and speculative ability.

A team of experts and teachers with an understanding of the subject and a proper role of examination worked hard to accomplish this task. The material was discussed, edited and finally included in this source book.

NCERT will welcome suggestions from students, teachers and parents which would help us to further improve the quality of material in subsequent editions.

New Delhi
21 May 2008

Professor Yash Pal
Chairperson
National Steering Committee
National Council of Educational
Research and Training

PREFACE

The Department of Education in Science and Mathematics (DESM), National Council of Educational Research and Training (NCERT), initiated the development of 'Exemplar Problems' in science and mathematics for secondary and higher secondary stages after completing the preparation of textbooks based on National Curriculum Framework–2005.

The main objective of the book on 'Exemplar Problems in Mathematics' is to provide the teachers and students a large number of quality problems with varying cognitive levels to facilitate teaching learning of concepts in mathematics that are presented through the textbook for Class X. It is envisaged that the problems included in this volume would help the teachers to design tasks to assess effectiveness of their teaching and to know about the achievement of their students besides facilitating preparation of balanced question papers for unit and terminal tests. The feedback based on the analysis of students' responses may help the teachers in further improving the quality of classroom instructions. In addition, the problems given in this book are also expected to help the teachers to perceive the basic characteristics of good quality questions and motivate them to frame similar questions on their own. Students can benefit themselves by attempting the exercises given in the book for self assessment and also in mastering the basic techniques of problem solving. Some of the questions given in the book are expected to challenge the understanding of the concepts of mathematics of the students and their ability to applying them in novel situations.

The problems included in this book were prepared through a series of workshops organised by the DESM for their development and refinement involving practicing teachers, subject experts from universities and institutes of higher learning, and the members of the mathematics group of the DESM whose names appear separately. We gratefully acknowledge their efforts and thank them for their valuable contribution in our endeavour to provide good quality instructional material for the school system.

I express my gratitude to Professor Krishna Kumar, *Director* and Professor G. Ravindra, *Joint Director*, NCERT for their valuable motivation and guidance from time to time. Special thanks are also due to Dr. R.P.Maurya, *Reader* in Mathematics, DESM for coordinating the programme, taking pains in editing and refinement of problems and for making the manuscript pressworthy.

We look forward to feedback from students, teachers and parents for further improvement of the contents of this book.

Hu kum Singh
Professor and Head

DEVELOPMENT TEAM
EXEMPLAR PROBLEMS – MATHEMATICS

MEMBERS

B.S. Upadhyaya, *Professor*, RIE, Mysore

G. P. Dikshit, *Professor* (Retd.), Lucknow University, Lucknow

Hukum Singh, *Professor and Head*, DESM, NCERT, New Delhi

J.C. Nijhawan, *Principal* (Retd.), Directorate of Education, Delhi

Mahendra Shankar, *Lecturer* (S.G) (Retd.), DESM, NCERT, New Delhi

P. Sinclair, *Professor and Pro Vice Chancellor*, IGNOU, New Delhi

P.K. Tiwari, *Assistant Commissioner* (Retd.), K.V. Sangathan, New Delhi

Ram Avtar, *Professor* (Retd.), DESM, NCERT, New Delhi

Sanjay Mudgal, *Lecturer*, DESM, NCERT, New Delhi

Vandita Kalra, *Lecturer*, Sarvodaya Kanya Vidyalaya, Vikaspuri, New Delhi

V. Madhvi, T.G.T., Sanskriti School, Chanakyapuri, New Delhi

V.P. Singh, *Reader*, DESM, NCERT, New Delhi

MEMBER - COORDINATOR

R.P. Maurya, *Reader*, DESM, NCERT, New Delhi

ACKNOWLEDGEMENTS

The Council gratefully acknowledges the valuable contributions of the following participants of the Exemplar Problems Workshop:

Mohammad Qasim, *TGT*, Anglo Arabic Senior Secondary School, Ajmeri Gate, Delhi; Ajay Kumar Singh, *TGT*, Ramjas Senior Secondary School No. 3, Chandani Chowk, Delhi; Jharna De, *TGT*, Dev Samaj Higher Secondary School, Nehru Nagar, New Delhi; Shailja Tiwari, *PGT*, K.V., NSG Campus, Manesar, Gurgaon, Haryana and Rashmi Bhartiya, *TGT*, DPS, Mathura Road, New Delhi,

Special thanks are due to Professor Hukum Singh, *Head*, DESM, NCERT for his support during the development of this book.

The Council also acknowledges the efforts of Deepak Kapoor, *Incharge*, Computer Station; Mrs. Praveen, Rakesh Kumar, Ishwar Singh and Narender Verma, *DTP Operators*; Abhimanu Mohanty, *Proof Reader*.

The contribution of APC Office, Administration of DESM, Publication Department and Secretariat of NCERT is also duly acknowledged.

STUDENTS' EVALUATION IN MATHEMATICS AT THE SECONDARY STAGE

A. Introduction

The fascinating world of mathematics provides an unlimited scope to mathematicians to perceive problems pertaining to three situations visualised in the forms of concrete, abstraction and intuition. However, due to abstraction and intuition, sometimes some of the mathematical concepts become quite complicated even for teachers who are actively engaged in mathematics teaching at various stages. This needs the exhaustive training in methods/pedagogy as well as in contents. This also needs the clarifications of mathematical concepts using instructional materials, experimentation, observation and practicals etc. to avoid the abstraction at various stages of schooling. Good mathematics instruction requires good teachers, and good teachers are those with pedagogical content knowledge who, in turn, are predominantly those with good content. Improvement of school mathematics education therefore begins with teaching teachers the mathematics they need. In other words, the most difficult demand for becoming a good teacher is to achieve a firm mastery of the mathematical content. Without such a mastery, good pedagogy is difficult. A firm mastery of the content opens up the world of pedagogy and offers many more effective pedagogical possibilities. Even best pedagogy lavished on incorrect mathematics may result in poor quality in teaching.

Mathematics as a science of abstract objects, relies on *logic* rather than on observation, yet it employs observation, simulation, and even experiments as means of discovering truth. The ability to reason and think clearly is extremely useful in our daily life, that is, developing children's abilities for *mathematisation* is the main goal of mathematics education as has been emphasised in National Curriculum Framework-2005 (NCF-2005). It is in this context that NCF-2005 has set two distinct targets for mathematics education at school level viz. *narrow* and *higher*. The narrow aim of school mathematics is to develop useful capabilities, particularly those relating to numeracy- number, number operations, measurements, decimals and percentages. The higher aim is to develop the child's resources to think and reason mathematically, to pursue assumptions to their logical conclusions and to handle abstractions. It includes a way of doing things, and the ability and the attitude to formulate and solve problems. This calls for curriculum to be ambitious in the sense that it seeks to achieve the higher aim mentioned above, rather than only the narrow aim. It should be coherent in the

sense that the variety of methods and skills available piecemeal (in arithmetic, algebra, geometry) cohere into an ability to address problems that come from other domains such as sciences and in social studies at secondary stage. It should be important in the sense that students feel the need to solve such problems.

Evaluation is a very comprehensive term which, in general, includes evaluating any object, individual, event, trend, etc. A most common type of individual evaluation is the evaluation of a student. It includes the assessments of the performance of the student in the areas of her personality development in terms of intellectual, social and emotional developments after she has been provided learning experiences through classroom processes. Besides the factors like quality of teaching curricular materials, instructional technology, school infrastructure and societal support also influence the learning and experiences. In educational terminology, these areas of personality development are called scholastic and co-scholastic areas. Due to its wider applications in various other fields, mathematics is the most important scholastic area. It is for this reason, mathematics is a compulsory subject up to the secondary stage from quite a long time. This is the stage which acts as a bridge between the students who will continue with Mathematics in higher classes. Therefore, evaluation of Mathematics at this stage requires special attention. This evaluation is done to assess whether the main aim or objectives laid down in NCF-2005 have been achieved by the students or not?

B. Purposes of Evaluation

There are various purposes of evaluation. Some of these are to know the answers for the following questions:

- (i) How has the teaching been effective?
- (ii) Which method is more suitable for teaching a particular topic or concept?
- (iii) To what extent students are ready to learn a particular topic?
- (iv) What type of learning difficulties are faced by the students?
- (v) Do the students require remedial measures?
- (vi) Which students are to be provided some enrichment materials?
- (vii) Which topics are more difficult for the student?
- (viii) Is there a need to make a change in the teaching strategy for a particular topic?
- (ix) How can the result of the evaluation can be utilised for the all round development of students?

C. Types of Evaluation

Evaluation is mainly of two types namely

(i) **Summative** and (ii) **Formative**

- (i) **Summative Evaluation:** It is done at the end of the course or a term. It involves a formal testing of the student's achievements and is used for grading, ranking and certifying the achievements of the students.
- (ii) **Formative Evaluation:** It is in-built in the teaching learning process. It is a continuous process going on throughout the course. The purpose of such evaluation is to obtain feedback so that teaching or instructional strategies could be improved. Further, on the basis of the feedback, strategies and weaknesses of the students can be assessed.

NCF-2005 has also given more stress on continuous and comprehensive evaluation in comparison to the summative evaluation. For this, a mathematics teacher may

- (i) ask some questions to know to what extent the students understand about the new concept to be taught before it is started.
- (ii) ask questions at regular intervals to check the understanding of students during the presentation of a concept.
- (iii) assess students by the questions asked by them during the teaching of a chapter.
- (iv) assess the students during class work.
- (v) assess students on the basis of the home assignments given to them.
- (vi) assess students by asking some questions at the end of the chapter.
- (vii) encourage peer group members (students) to evaluate one another. This may be called as **Peer Evaluation**. This evaluation can bring out the hidden talents among the students.

Thus, whatever may be the way of evaluation, it is done through some well thought questions, which may be referred to as **good questions**.

D. Characteristics of a Good Question

Quality of a question depends on the situation where it is to be used. In general, following are some of the characteristics of a 'good question':

- (i) **Validity:** A question is said to be valid, if it serves the purpose for which it has been framed.

Thus, for a question to be valid, it must be based on (a) a specified content area and also on (b) a predetermined aim or objective.

In case it is not valid, it will be treated as a question 'out of course or syllabus'.

(ii) **Reliability:** A question is said to be reliable, if its answer gives the true achievement of the student. In other words, the achievement of the student must be free from chance errors. These errors, generally, occur due to vagueness of language or direction provided in the question. They may occur (1) at the time when the student is answering the question and (2) at the time when the teacher is evaluating the answer. In view of the above, following steps can ensure higher reliability of a question:

- (a) The question should admit of one and only one interpretation.
- (b) The scope of the answer must be clear.
- (c) The directions to the question must be clear.
- (d) A well thought marking scheme should be provided for the question.

(iii) **Difficulty Level:** Difficulty level is a very important characteristic of a question. In different situations, questions of different difficulty levels are needed. For example, for assessing the achievement of Minimum Level of Learning, there will always be a need of questions of lower difficulty level. Difficulty level of a question may be categorised in the following three types:

- (a) **Difficult:** Which could be done by about less than 30% of the students.
- (b) **Average:** Which could be done by $\geq 30\%$ but $\leq 70\%$ of the students.
- (c) **Easy:** Which could be done by more than 70% of the students.

These levels can be decided by the question framer herself on the basis of her own experiences.

(iv) **Language:** Language of a question must be simple and within the comprehension level of the student's vocabulary. It should not lead to different answers. However, if necessary, the same question can be presented before the students at different difficulty levels, by using a little different language or wordings.

(v) **Form:** There are different forms of questions and each form is more suitable than the other depending upon the situations. There may be several factors for choosing a particular form of questions. These may be one or more of the following:

- (a) Economy (b) Facility in printings (c) Ease in scoring and so on.

E. Different Forms of Questions

In general, the questions are of the following two forms:

- (1) Free Response Type and (2) Fixed Response Type

1. Free Response Questions: In a free response question, a student formulates and organizes her own answer. These type of questions are very much in use in the present system of examination. These are of two types, namely

(a) **Long Answer Questions**

A question which requires comparatively a lengthy answer is called a long answer type question. These questions require the student to select relevant facts, organise them and write answers in her own words. In these type of questions, there is a very little scope of guessing. However, if there are more number of long answer questions, then the possibility of covering the whole content area in the examination will become less. To overcome this difficulty, we may choose such long answer type questions which involve more than one content areas.

(b) **Short Answer Questions**

A question in which a student is expected to write the answer in 3 or 4 lines is called a short answer type question. In these questions, the coverage of content areas is more specific and definite. It may be noted that a question whose answer may be a simple diagram is also considered to be a short answer type question.

2. Fixed Response Questions: In these type of questions, the answer is fixed and definite. These type of questions are being encouraged due to their objectivity in scoring. They are also of two types, namely

(a) **Very Short Answer Questions**

A question in which a student is expected to give the answer in just one word or a phrase is called a very short answer type question. In mathematics, by a word or a phrase, we generally mean a group of symbols or numbers (numerals). It is expected to take 1 to 3 minutes to answer such a question. Fill in the blanks question is one of the examples of such type of questions.

(b) **Objective Questions**

An objective type question is one in which alternate answers are given and student has to just indicate the correct answer. These questions can also be answered in just 1 to 3 minutes. They can be further classified into the following forms:

(i) **True-False Type:** In these type of questions, a statement or formula is given and the student is expected to write whether it is 'True' or 'False'.

(ii) **Matching Type:** These type of questions consist of two columns. The student has to pair each item of first column with some item of the second column on the basis of some criterion. The number of items in the second column may be more than that of the first column.

(iii) **Sentence Completion Type:** In these type of questions, the student has to complete the given sentence using one or more words given in brackets along with the question.

(iv) **Multiple Choice Type:** In these type of questions, number of alternatives (usually called distracters), only one is appropriate or correct. The student is expected to write or tick (✓) the correct alternative.

In the fixed response questions, the scope of guess work is very high. However, this can be minimised by attaching some element of reasoning in such questions. We may call these questions as **Short Answer Questions with Reasoning**.

F. Instructional Objectives

As already stated, a question is said to be valid if it also based on a predetermined objective. The word 'objective' is a wider term. Objectives are divided into two groups, namely (1) educational objectives and (2) instructional objectives. Educational objectives play a directive role in the process of education, while instructional objectives are those goals for the achievement of which all educational efforts are directed. Mathematics is a special language with its own vocabulary and grammar. The vocabulary consists of concepts, terms, facts, symbols, assumptions, etc., while the grammar relates to principles, processes, functional relationships, etc. Knowledge and understanding of these and their applications to new situations have helped mankind to achieve tremendous progress in various fields. Therefore, the main instructional objectives for mathematics are as follows:

1. Knowledge with Specifications

The students

- 1.1 recall or reproduce terms, facts, etc.
- 1.2 recognise terms, symbols, concepts, etc.

2. Understanding with Specifications

The students

- 2.1 give illustrations for terms, definitions, etc.
- 2.2 detect conceptual errors (and correct) in definitions, statements, formulae, etc.
- 2.3 compare concepts, quantities, etc.
- 2.4 discriminate between closely related concepts
- 2.5 translate verbal statements into mathematical statements and vice-versa
- 2.6 verify the results arrived at
- 2.7 classify data as per criteria
- 2.8 find relationships among the given data
- 2.9 interpret the data

3. Application with Specification

The students

- 3.1 analyse and find out what is given and what is required to be done
- 3.2 find out the adequacy, superflousity and relevancy of data
- 3.3 establish relationship among the data

- 3.4 reason out deductively
- 3.5 select appropriate methods for solutions of problems
- 3.6 suggest alternative methods for solving problems
- 3.7 generalise from particular situations

4. Skill with Specifications

The students

- 4.1 Carry out calculation easily and quickly
- 4.2 Handle geometrical instruments properly
- 4.3 Draw figure accurately and to the scale
- 4.4 Read tables and graphs properly
- 4.5 Interpret graphs correctly

As far as the main goal or objective in the NCF-2005 is concerned, it is to develop abilities in the student for mathematisation. It also states (1) the narrow aims of school mathematics, which concern with decimals and percents and (2) the higher aims, which are for developing the child resources to think and reason mathematically, to pursue assumption to their logical conclusions and to handle abstractions. Keeping this in view, at this stage, the stress is only on the higher aims. These higher aims may be considered as the instructional objectives. Objective based questions and objective type questions are often confused with each other. When a question is framed keeping a definite aim or objective in mind, it is called an objective based question, while if a question is framed to measure the students achievement which is objective rather than subjective is called objective type question. It may also be noted that determination of the objective of a question varies from person to person. For example, a question may appear to be of 'knowledge' type to one teacher who may think that the answer of the question is known to the students, but the same question may appear to be of understanding type to another teacher if she thinks that the question is completely unknown to the same group of students. In the light of the views expressed in NCF-2005, the following types of questions are suggested:

1. Long answer questions
2. Short answer questions
3. Short answer questions with reasoning
4. Multiple choice questions

It is hoped that these questions along with the questions in the textbook would be effectively able to evaluate the Classes IX and X students in mathematics.

CONTENTS

FOREWORD		iii
PREFACE		v
STUDENTS' EVALUATION IN MATHEMATICS AT SECONDARY STAGE		viii
CHAPTER 1	Real Numbers	1
CHAPTER 2	Polynomials	8
CHAPTER 3	Pair of Linear Equations in Two Variables	16
CHAPTER 4	Quadratic Equations	35
CHAPTER 5	Arithmetic Progressions	44
CHAPTER 6	Triangles	59
CHAPTER 7	Coordinate Geometry	77
CHAPTER 8	Introduction to Trigonometry and its Applications	87
CHAPTER 9	Circles	101
CHAPTER 10	Constructions	113
CHAPTER 11	Area Related to Circles	119
CHAPTER 12	Surface Areas and Volumes	136
CHAPTER 13	Statistics and Probability	153
Answers		183
	Design of the Question Paper , Set-I	203
	Design of the Question Paper, Set-II	219

THE CONSTITUTION OF INDIA

PREAMBLE

WE, THE PEOPLE OF INDIA, having solemnly resolved to constitute India into a **SOVEREIGN SOCIALIST SECULAR DEMOCRATIC REPUBLIC** and to secure to all its citizens :

JUSTICE, social, economic and political;

LIBERTY of thought, expression, belief, faith and worship;

EQUALITY of status and of opportunity; and to promote among them all

FRATERNITY assuring the dignity of the individual and the unity and integrity of the Nation;

IN OUR CONSTITUENT ASSEMBLY this twenty-sixth day of November, 1949, do **HEREBY ADOPT, ENACT AND GIVE TO OURSELVES THIS CONSTITUTION.**

REAL NUMBERS

(A) Main Concepts and Results

- Euclid's Division Lemma : Given two positive integers a and b , there exist unique integers q and r satisfying $a = bq + r$, $0 \leq r < b$.
- Euclid's Division Algorithm to obtain the HCF of two positive integers, say c and d , $c > d$.
Step 1 : Apply Euclid's division lemma to c and d , to find whole numbers q and r , such that $c = dq + r$, $0 \leq r < d$.
Step 2 : If $r = 0$, d is the HCF of c and d . If $r \neq 0$, apply the division lemma to d and r .
Step 3 : Continue the process till the remainder is zero. The divisor at this stage will be the required HCF.
- Fundamental Theorem of Arithmetic : Every composite number can be expressed as a product of primes, and this expression (factorisation) is unique, apart from the order in which the prime factors occur.
- Let p be a prime number. If p divides a^2 , then p divides a , where a is a positive integer.
- $\sqrt{2}$, $\sqrt{3}$, $\sqrt{5}$ are irrational numbers.
- The sum or difference of a rational and an irrational number is irrational.
- The product or quotient of a non-zero rational number and an irrational number is irrational.
- For any two positive integers a and b , $\text{HCF}(a, b) \times \text{LCM}(a, b) = a \times b$.

- Let $x = \frac{p}{q}$, p and q are co-prime, be a rational number whose decimal expansion terminates. Then, the prime factorisation of q is of the form $2^m \cdot 5^n$; m, n are non-negative integers.
- Let $x = \frac{p}{q}$ be a rational number such that the prime factorisation of q is not of the form $2^m \cdot 5^n$; m, n being non-negative integers. Then, x has a non-terminating repeating decimal expansion.

(B) Multiple Choice Questions

Choose the correct answer from the given four options:

Sample Question 1 : The decimal expansion of the rational number $\frac{33}{2^2 \cdot 5}$ will terminate after

- (A) one decimal place (B) two decimal places
(C) three decimal places (D) more than 3 decimal places

Solution : Answer (B)

Sample Question 2 : Euclid's division lemma states that for two positive integers a and b , there exist unique integers q and r such that $a = bq + r$, where r must satisfy

- (A) $1 < r < b$ (B) $0 < r \leq b$
(C) $0 \leq r < b$ (D) $0 < r < b$

Solution : Answer (C)

EXERCISE 1.1

Choose the correct answer from the given four options in the following questions:

- For some integer m , every even integer is of the form

(A) m (B) $m + 1$
(C) $2m$ (D) $2m + 1$
- For some integer q , every odd integer is of the form

(A) q (B) $q + 1$
(C) $2q$ (D) $2q + 1$

3. $n^2 - 1$ is divisible by 8, if n is
(A) an integer (B) a natural number
(C) an odd integer (D) an even integer
4. If the HCF of 65 and 117 is expressible in the form $65m - 117$, then the value of m is
(A) 4 (B) 2
(C) 1 (D) 3
5. The largest number which divides 70 and 125, leaving remainders 5 and 8, respectively, is
(A) 13 (B) 65
(C) 875 (D) 1750
6. If two positive integers a and b are written as
 $a = x^3y^2$ and $b = xy^3$; x, y are prime numbers, then HCF (a, b) is
(A) xy (B) xy^2 (C) x^3y^3 (D) x^2y^2
7. If two positive integers p and q can be expressed as
 $p = ab^2$ and $q = a^3b$; a, b being prime numbers, then LCM (p, q) is
(A) ab (B) a^2b^2 (C) a^3b^2 (D) a^3b^3
8. The product of a non-zero rational and an irrational number is
(A) always irrational (B) always rational
(C) rational or irrational (D) one
9. The least number that is divisible by all the numbers from 1 to 10 (both inclusive) is
(A) 10 (B) 100 (C) 504 (D) 2520
10. The decimal expansion of the rational number $\frac{14587}{1250}$ will terminate after:
(A) one decimal place (B) two decimal places
(C) three decimal places (D) four decimal places

(C) Short Answer Questions with Reasoning

Sample Question 1: The values of the remainder r , when a positive integer a is divided by 3 are 0 and 1 only. Justify your answer.

Solution : No.

According to Euclid's division lemma,

$$a = 3q + r, \text{ where } 0 \leq r < 3$$

and r is an integer. Therefore, the values of r can be 0, 1 or 2.

Sample Question 2: Can the number 6^n , n being a natural number, end with the digit 5? Give reasons.

Solution : No, because $6^n = (2 \times 3)^n = 2^n \times 3^n$, so the only primes in the factorisation of 6^n are 2 and 3, and not 5.

Hence, it cannot end with the digit 5.

EXERCISE 1.2

1. Write whether every positive integer can be of the form $4q + 2$, where q is an integer. Justify your answer.
2. "The product of two consecutive positive integers is divisible by 2". Is this statement true or false? Give reasons.
3. "The product of three consecutive positive integers is divisible by 6". Is this statement true or false"? Justify your answer.
4. Write whether the square of any positive integer can be of the form $3m + 2$, where m is a natural number. Justify your answer.
5. A positive integer is of the form $3q + 1$, q being a natural number. Can you write its square in any form other than $3m + 1$, i.e., $3m$ or $3m + 2$ for some integer m ? Justify your answer.
6. The numbers 525 and 3000 are both divisible only by 3, 5, 15, 25 and 75. What is HCF (525, 3000)? Justify your answer.
7. Explain why $3 \times 5 \times 7 + 7$ is a composite number.
8. Can two numbers have 18 as their HCF and 380 as their LCM? Give reasons.
9. Without actually performing the long division, find if $\frac{987}{10500}$ will have terminating or non-terminating (repeating) decimal expansion. Give reasons for your answer.
10. A rational number in its decimal expansion is 327.7081. What can you say about the prime factors of q , when this number is expressed in the form $\frac{p}{q}$? Give reasons.

(D) Short Answer Questions

Sample Question 1: Using Euclid's division algorithm, find which of the following pairs of numbers are co-prime:

- (i) 231, 396 (ii) 847, 2160

Solution : Let us find the HCF of each pair of numbers.

$$(i) \quad 396 = 231 \times 1 + 165$$

$$231 = 165 \times 1 + 66$$

$$165 = 66 \times 2 + 33$$

$$66 = 33 \times 2 + 0$$

Therefore, HCF = 33. Hence, numbers are not co-prime.

$$(ii) \quad 2160 = 847 \times 2 + 466$$

$$847 = 466 \times 1 + 381$$

$$466 = 381 \times 1 + 85$$

$$381 = 85 \times 4 + 41$$

$$85 = 41 \times 2 + 3$$

$$41 = 3 \times 13 + 2$$

$$3 = 2 \times 1 + 1$$

$$2 = 1 \times 2 + 0$$

Therefore, the HCF = 1. Hence, the numbers are co-prime.

Sample Question 2: Show that the square of an odd positive integer is of the form $8m + 1$, for some whole number m .

Solution: Any positive odd integer is of the form $2q + 1$, where q is a whole number.

$$\text{Therefore, } (2q + 1)^2 = 4q^2 + 4q + 1 = 4q(q + 1) + 1, \quad (1)$$

$q(q + 1)$ is either 0 or even. So, it is $2m$, where m is a whole number.

$$\text{Therefore, } (2q + 1)^2 = 4.2m + 1 = 8m + 1. \quad [\text{From (1)}]$$

Sample Question 3: Prove that $\sqrt{2} + \sqrt{3}$ is irrational.

Solution : Let us suppose that $\sqrt{2} + \sqrt{3}$ is rational. Let $\sqrt{2} + \sqrt{3} = a$, where a is rational.

Therefore, $\sqrt{2} = a - \sqrt{3}$

Squaring on both sides, we get

$$2 = a^2 + 3 - 2a\sqrt{3}$$

Therefore, $\sqrt{3} = \frac{a^2 + 1}{2a}$, which is a contradiction as the right hand side is a rational number while $\sqrt{3}$ is irrational. Hence, $\sqrt{2} + \sqrt{3}$ is irrational.

EXERCISE 1.3

1. Show that the square of any positive integer is either of the form $4q$ or $4q + 1$ for some integer q .
2. Show that cube of any positive integer is of the form $4m$, $4m + 1$ or $4m + 3$, for some integer m .
3. Show that the square of any positive integer cannot be of the form $5q + 2$ or $5q + 3$ for any integer q .
4. Show that the square of any positive integer cannot be of the form $6m + 2$ or $6m + 5$ for any integer m .
5. Show that the square of any odd integer is of the form $4q + 1$, for some integer q .
6. If n is an odd integer, then show that $n^2 - 1$ is divisible by 8.
7. Prove that if x and y are both odd positive integers, then $x^2 + y^2$ is even but not divisible by 4.
8. Use Euclid's division algorithm to find the HCF of 441, 567, 693.
9. Using Euclid's division algorithm, find the largest number that divides 1251, 9377 and 15628 leaving remainders 1, 2 and 3, respectively.
10. Prove that $\sqrt{3} + \sqrt{5}$ is irrational.
11. Show that 12^n cannot end with the digit 0 or 5 for any natural number n .
12. On a morning walk, three persons step off together and their steps measure 40 cm, 42 cm and 45 cm, respectively. What is the minimum distance each should walk so that each can cover the same distance in complete steps?

13. Write the denominator of the rational number $\frac{257}{5000}$ in the form $2^m \times 5^n$, where m, n are non-negative integers. Hence, write its decimal expansion, without actual division.

14. Prove that $\sqrt{p} + \sqrt{q}$ is irrational, where p, q are primes.

(E) Long Answer Questions

Sample Question 1 : Show that the square of an odd positive integer can be of the form $6q + 1$ or $6q + 3$ for some integer q .

Solution : We know that any positive integer can be of the form $6m, 6m + 1, 6m + 2, 6m + 3, 6m + 4$ or $6m + 5$, for some integer m .

Thus, an odd positive integer can be of the form $6m + 1, 6m + 3$, or $6m + 5$
Thus we have:

$$(6m + 1)^2 = 36m^2 + 12m + 1 = 6(6m^2 + 2m) + 1 = 6q + 1, q \text{ is an integer}$$

$$(6m + 3)^2 = 36m^2 + 36m + 9 = 6(6m^2 + 6m + 1) + 3 = 6q + 3, q \text{ is an integer}$$

$$(6m + 5)^2 = 36m^2 + 60m + 25 = 6(6m^2 + 10m + 4) + 1 = 6q + 1, q \text{ is an integer.}$$

Thus, the square of an odd positive integer can be of the form $6q + 1$ or $6q + 3$.

EXERCISE 1.4

1. Show that the cube of a positive integer of the form $6q + r$, q is an integer and $r = 0, 1, 2, 3, 4, 5$ is also of the form $6m + r$.
2. Prove that one and only one out of $n, n + 2$ and $n + 4$ is divisible by 3, where n is any positive integer.
3. Prove that one of any three consecutive positive integers must be divisible by 3.
4. For any positive integer n , prove that $n^3 - n$ is divisible by 6.
5. Show that one and only one out of $n, n + 4, n + 8, n + 12$ and $n + 16$ is divisible by 5, where n is any positive integer.

[Hint: Any positive integer can be written in the form $5q, 5q+1, 5q+2, 5q+3, 5q+4$].

POLYNOMIALS

(A) Main Concepts and Results

- Geometrical meaning of zeroes of a polynomial: The zeroes of a polynomial $p(x)$ are precisely the x -coordinates of the points where the graph of $y = p(x)$ intersects the x -axis.
- Relation between the zeroes and coefficients of a polynomial: If α and β are the zeroes of a quadratic polynomial $ax^2 + bx + c$, then $\alpha + \beta = -\frac{b}{a}$, $\alpha\beta = \frac{c}{a}$.
- If α , β and γ are the zeroes of a cubic polynomial $ax^3 + bx^2 + cx + d$, then $\alpha + \beta + \gamma = -\frac{b}{a}$, $\alpha\beta + \beta\gamma + \gamma\alpha = \frac{c}{a}$ and $\alpha\beta\gamma = -\frac{d}{a}$.
- The division algorithm states that given any polynomial $p(x)$ and any non-zero polynomial $g(x)$, there are polynomials $q(x)$ and $r(x)$ such that $p(x) = g(x)q(x) + r(x)$, where $r(x) = 0$ or $\text{degree } r(x) < \text{degree } g(x)$.

(B) Multiple Choice Questions

Choose the correct answer from the given four options:

Sample Question 1: If one zero of the quadratic polynomial $x^2 + 3x + k$ is 2, then the value of k is

- (A) 10 (B) -10 (C) 5 (D) -5

Solution : Answer (B)

Sample Question 2: Given that two of the zeroes of the cubic polynomial $ax^3 + bx^2 + cx + d$ are 0, the third zero is

- (A) $\frac{-b}{a}$ (B) $\frac{b}{a}$ (C) $\frac{c}{a}$ (D) $-\frac{d}{a}$

Solution : Answer (A). [Hint: Because if third zero is α , sum of the zeroes $= \alpha + 0 + 0 = \frac{-b}{a}$]

EXERCISE 2.1

Choose the correct answer from the given four options in the following questions:

1. If one of the zeroes of the quadratic polynomial $(k-1)x^2 + kx + 1$ is -3 , then the value of k is

- (A) $\frac{4}{3}$ (B) $\frac{-4}{3}$ (C) $\frac{2}{3}$ (D) $\frac{-2}{3}$

2. A quadratic polynomial, whose zeroes are -3 and 4 , is

- (A) $x^2 - x + 12$ (B) $x^2 + x + 12$
 (C) $\frac{x^2}{2} - \frac{x}{2} - 6$ (D) $2x^2 + 2x - 24$

3. If the zeroes of the quadratic polynomial $x^2 + (a+1)x + b$ are 2 and -3 , then

- (A) $a = -7, b = -1$ (B) $a = 5, b = -1$
 (C) $a = 2, b = -6$ (D) $a = 0, b = -6$

4. The number of polynomials having zeroes as -2 and 5 is

- (A) 1 (B) 2 (C) 3 (D) more than 3

5. Given that one of the zeroes of the cubic polynomial $ax^3 + bx^2 + cx + d$ is zero, the product of the other two zeroes is

- (A) $-\frac{c}{a}$ (B) $\frac{c}{a}$ (C) 0 (D) $-\frac{b}{a}$

6. If one of the zeroes of the cubic polynomial $x^3 + ax^2 + bx + c$ is -1 , then the product of the other two zeroes is

- (A) $b - a + 1$ (B) $b - a - 1$ (C) $a - b + 1$ (D) $a - b - 1$

7. The zeroes of the quadratic polynomial $x^2 + 99x + 127$ are
 (A) both positive (B) both negative
 (C) one positive and one negative (D) both equal
8. The zeroes of the quadratic polynomial $x^2 + kx + k$, $k \neq 0$,
 (A) cannot both be positive (B) cannot both be negative
 (C) are always unequal (D) are always equal
9. If the zeroes of the quadratic polynomial $ax^2 + bx + c$, $c \neq 0$ are equal, then
 (A) c and a have opposite signs (B) c and b have opposite signs
 (C) c and a have the same sign (D) c and b have the same sign
10. If one of the zeroes of a quadratic polynomial of the form $x^2 + ax + b$ is the negative of the other, then it
 (A) has no linear term and the constant term is negative.
 (B) has no linear term and the constant term is positive.
 (C) can have a linear term but the constant term is negative.
 (D) can have a linear term but the constant term is positive.
11. Which of the following is not the graph of a quadratic polynomial?

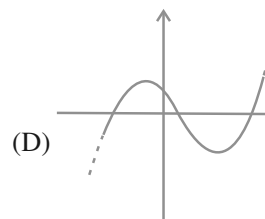
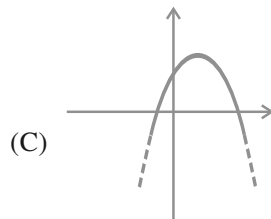
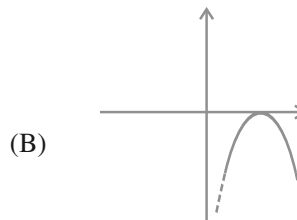
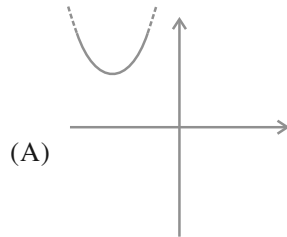

(C) Short Answer Questions with Reasoning

Sample Question 1: Can $x - 1$ be the remainder on division of a polynomial $p(x)$ by $2x + 3$? Justify your answer.

Solution : No, since degree $(x - 1) = 1 =$ degree $(2x + 3)$.

Sample Question 2: Is the following statement True or False? Justify your answer.

If the zeroes of a quadratic polynomial $ax^2 + bx + c$ are both negative, then a, b and c all have the same sign.

Solution : True, because $-\frac{b}{a} =$ sum of the zeroes < 0 , so that $\frac{b}{a} > 0$. Also the product of the zeroes $= \frac{c}{a} > 0$.

EXERCISE 2.2

1. Answer the following and justify:
 - (i) Can $x^2 - 1$ be the quotient on division of $x^6 + 2x^3 + x - 1$ by a polynomial in x of degree 5?
 - (ii) What will the quotient and remainder be on division of $ax^2 + bx + c$ by $px^3 + qx^2 + rx + s, p \neq 0$?
 - (iii) If on division of a polynomial $p(x)$ by a polynomial $g(x)$, the quotient is zero, what is the relation between the degrees of $p(x)$ and $g(x)$?
 - (iv) If on division of a non-zero polynomial $p(x)$ by a polynomial $g(x)$, the remainder is zero, what is the relation between the degrees of $p(x)$ and $g(x)$?
 - (v) Can the quadratic polynomial $x^2 + kx + k$ have equal zeroes for some odd integer $k > 1$?
2. Are the following statements 'True' or 'False'? Justify your answers.
 - (i) If the zeroes of a quadratic polynomial $ax^2 + bx + c$ are both positive, then a, b and c all have the same sign.
 - (ii) If the graph of a polynomial intersects the x -axis at only one point, it cannot be a quadratic polynomial.
 - (iii) If the graph of a polynomial intersects the x -axis at exactly two points, it need not be a quadratic polynomial.
 - (iv) If two of the zeroes of a cubic polynomial are zero, then it does not have linear and constant terms.

- (v) If all the zeroes of a cubic polynomial are negative, then all the coefficients and the constant term of the polynomial have the same sign.
- (vi) If all three zeroes of a cubic polynomial $x^3 + ax^2 - bx + c$ are positive, then at least one of a , b and c is non-negative.
- (vii) The only value of k for which the quadratic polynomial $kx^2 + x + k$ has equal zeros is $\frac{1}{2}$

(D) Short Answer Questions

Sample Question 1: Find the zeroes of the polynomial $x^2 + \frac{1}{6}x - 2$, and verify the relation between the coefficients and the zeroes of the polynomial.

$$\begin{aligned} \text{Solution : } x^2 + \frac{1}{6}x - 2 &= \frac{1}{6}(6x^2 + x - 12) = \frac{1}{6}[6x^2 + 9x - 8x - 12] \\ &= \frac{1}{6}[3x(2x + 3) - 4(2x + 3)] = \frac{1}{6}(3x - 4)(2x + 3) \end{aligned}$$

Hence, $\frac{4}{3}$ and $-\frac{3}{2}$ are the zeroes of the given polynomial.

The given polynomial is $x^2 + \frac{1}{6}x - 2$.

$$\text{The sum of zeroes} = \frac{4}{3} + -\frac{3}{2} = \frac{-1}{6} = -\frac{\text{Coefficient of } x}{\text{Coefficient of } x^2} \text{ and}$$

$$\text{the product of zeroes} = \frac{4}{3} \times -\frac{3}{2} = -2 = \frac{\text{Constant term}}{\text{Coefficient of } x^2}$$

EXERCISE 2.3

Find the zeroes of the following polynomials by factorisation method and verify the relations between the zeroes and the coefficients of the polynomials:

1. $4x^2 - 3x - 1$

2. $3x^2 + 4x - 4$

3. $5t^2 + 12t + 7$

4. $t^3 - 2t^2 - 15t$

5. $2x^2 + \frac{7}{2}x + \frac{3}{4}$

6. $4x^2 + 5\sqrt{2}x - 3$

7. $2s^2 - (1 + 2\sqrt{2})s + \sqrt{2}$

8. $v^2 + 4\sqrt{3}v - 15$

9. $y^2 + \frac{3}{2}\sqrt{5}y - 5$

10. $7y^2 - \frac{11}{3}y - \frac{2}{3}$

(E) Long Answer Questions

Sample Question 1: Find a quadratic polynomial, the sum and product of whose zeroes are $\sqrt{2}$ and $-\frac{3}{2}$, respectively. Also find its zeroes.

Solution : A quadratic polynomial, the sum and product of whose zeroes are

$\sqrt{2}$ and $-\frac{3}{2}$ is $x^2 - \sqrt{2}x - \frac{3}{2}$

$$\begin{aligned} x^2 - \sqrt{2}x - \frac{3}{2} &= \frac{1}{2} [2x^2 - 2\sqrt{2}x - 3] \\ &= \frac{1}{2} [2x^2 + \sqrt{2}x - 3\sqrt{2}x - 3] \\ &= \frac{1}{2} [\sqrt{2}x(\sqrt{2}x + 1) - 3(\sqrt{2}x + 1)] \\ &= \frac{1}{2} [\sqrt{2}x + 1][\sqrt{2}x - 3] \end{aligned}$$

Hence, the zeroes are $-\frac{1}{\sqrt{2}}$ and $\frac{3}{\sqrt{2}}$.

Sample Question 2: If the remainder on division of $x^3 + 2x^2 + kx + 3$ by $x - 3$ is 21, find the quotient and the value of k . Hence, find the zeroes of the cubic polynomial $x^3 + 2x^2 + kx - 18$.

Solution : Let $p(x) = x^3 + 2x^2 + kx + 3$

Then, $p(3) = 3^3 + 2 \times 3^2 + 3k + 3 = 21$

i.e., $3k = -27$

i.e., $k = -9$

Hence, the given polynomial will become $x^3 + 2x^2 - 9x + 3$.

Now, $(x - 3) x^3 + 2x^2 - 9x + 3(x^2 + 5x + 6)$

$$\begin{array}{r} x^3 - 3x^2 \\ \hline 5x^2 - 9x + 3 \\ 5x^2 - 15x \\ \hline 6x + 3 \\ 6x - 18 \\ \hline 21 \end{array}$$

So, $x^3 + 2x^2 - 9x + 3 = (x^2 + 5x + 6)(x - 3) + 21$

i.e., $x^3 + 2x^2 - 9x - 18 = (x - 3)(x^2 + 5x + 6)$

$$= (x - 3)(x + 2)(x + 3)$$

So, the zeroes of $x^3 + 2x^2 + kx - 18$ are 3, -2, -3.

EXERCISE 2.4

1. For each of the following, find a quadratic polynomial whose sum and product respectively of the zeroes are as given. Also find the zeroes of these polynomials by factorisation.

(i) $\frac{-8}{3}, \frac{4}{3}$

(ii) $\frac{21}{8}, \frac{5}{16}$

(iii) $-2\sqrt{3}, -9$

(iv) $\frac{-3}{2\sqrt{5}}, -\frac{1}{2}$

2. Given that the zeroes of the cubic polynomial $x^3 - 6x^2 + 3x + 10$ are of the form $a, a + b, a + 2b$ for some real numbers a and b , find the values of a and b as well as the zeroes of the given polynomial.

3. Given that $\sqrt{2}$ is a zero of the cubic polynomial $6x^3 + \sqrt{2}x^2 - 10x - 4\sqrt{2}$, find its other two zeroes.
4. Find k so that $x^2 + 2x + k$ is a factor of $2x^4 + x^3 - 14x^2 + 5x + 6$. Also find all the zeroes of the two polynomials.
5. Given that $x - \sqrt{5}$ is a factor of the cubic polynomial $x^3 - 3\sqrt{5}x^2 + 13x - 3\sqrt{5}$, find all the zeroes of the polynomial.
6. For which values of a and b , are the zeroes of $q(x) = x^3 + 2x^2 + a$ also the zeroes of the polynomial $p(x) = x^5 - x^4 - 4x^3 + 3x^2 + 3x + b$? Which zeroes of $p(x)$ are not the zeroes of $q(x)$?

PAIR OF LINEAR EQUATIONS IN TWO VARIABLES

(A) Main Concepts and Results

- Two linear equations in the same two variables are said to form a pair of linear equations in two variables.

- The most general form of a pair of linear equations is

$$a_1x + b_1y + c_1 = 0$$

$$a_2x + b_2y + c_2 = 0,$$

where $a_1, a_2, b_1, b_2, c_1, c_2$ are real numbers, such that $a_1^2 + b_1^2 \neq 0, a_2^2 + b_2^2 \neq 0$.

- A pair of linear equations is consistent if it has a solution – either a unique or infinitely many.

In case of infinitely many solutions, the pair of linear equations is also said to be dependent. Thus, in this case, the pair of linear equations is dependent and consistent.

- A pair of linear equations is inconsistent, if it has no solution.
- Let a pair of linear equations in two variables be $a_1x + b_1y + c_1 = 0$ and $a_2x + b_2y + c_2 = 0$.

(I) If $\frac{a_1}{a_2} = \frac{b_1}{b_2}$, then

- (i) the pair of linear equations is consistent,
- (ii) the graph will be a pair of lines intersecting at a unique point, which is the solution of the pair of equations.

(II) If $\frac{a_1}{a_2} \neq \frac{b_1}{b_2} \neq \frac{c_1}{c_2}$, then

- (i) the pair of linear equations is inconsistent,
- (ii) the graph will be a pair of parallel lines and so the pair of equations will have no solution.

(III) If $\frac{a_1}{a_2} = \frac{b_1}{b_2} = \frac{c_1}{c_2}$, then

- (i) the pair of linear equations is dependent, and consistent,
- (ii) the graph will be a pair of coincident lines. Each point on the lines will be a solution, and so the pair of equations will have infinitely many solutions.

- A pair of linear equations can be solved algebraically by any of the following methods:
 - (i) Substitution Method
 - (ii) Elimination Method
 - (iii) Cross- multiplication Method
- The pair of linear equations can also be solved geometrically/graphically.

(B) Multiple Choice Questions

Choose the correct answer from the given four options:

Sample Question 1 : The pair of equations $5x - 15y = 8$ and $3x - 9y = \frac{24}{5}$ has

- (A) one solution
- (B) two solutions
- (C) infinitely many solutions
- (D) no solution

Solution : Answer (C)

Sample Question 2 : The sum of the digits of a two-digit number is 9. If 27 is added to it, the digits of the number get reversed. The number is

- (A) 25 (B) 72 (C) 63 (D) 36

Solution : Answer (D)

EXERCISE 3.1

Choose the correct answer from the given four options:

1. Graphically, the pair of equations

$$6x - 3y + 10 = 0$$

$$2x - y + 9 = 0$$

represents two lines which are

- (A) intersecting at exactly one point. (B) intersecting at exactly two points.
(C) coincident. (D) parallel.
2. The pair of equations $x + 2y + 5 = 0$ and $-3x - 6y + 1 = 0$ have
(A) a unique solution (B) exactly two solutions
(C) infinitely many solutions (D) no solution
3. If a pair of linear equations is consistent, then the lines will be
(A) parallel (B) always coincident
(C) intersecting or coincident (D) always intersecting
4. The pair of equations $y = 0$ and $y = -7$ has
(A) one solution (B) two solutions
(C) infinitely many solutions (D) no solution
5. The pair of equations $x = a$ and $y = b$ graphically represents lines which are
(A) parallel (B) intersecting at (b, a)
(C) coincident (D) intersecting at (a, b)
6. For what value of k , do the equations $3x - y + 8 = 0$ and $6x - ky = -16$ represent coincident lines?
(A) $\frac{1}{2}$ (B) $-\frac{1}{2}$ (C) 2 (D) -2

(C) Short Answer Questions with Reasoning

Sample Question 1: Is it true to say that the pair of equations

$$-x + 2y + 2 = 0 \text{ and } \frac{1}{2}x - \frac{1}{4}y - 1 = 0$$

has a unique solution? Justify your answer.

Solution : Yes.

$$\text{Here, } \frac{a_1}{a_2} = \frac{-1}{\frac{1}{2}} = -2, \quad \frac{b_1}{b_2} = \frac{2}{-\frac{1}{4}} = -8$$

As $\frac{a_1}{a_2} \neq \frac{b_1}{b_2}$, the pair of equations has a unique solution.

Sample Question 2 : Do the equations $4x + 3y - 1 = 5$ and $12x + 9y = 15$ represent a pair of coincident lines? Justify your answer.

Solution : No.

We may rewrite the equations as

$$4x + 3y = 6$$

$$12x + 9y = 15$$

$$\text{Here, } \frac{a_1}{a_2} = \frac{4}{12} = \frac{1}{3}, \quad \frac{b_1}{b_2} = \frac{3}{9} = \frac{1}{3} \text{ and } \frac{c_1}{c_2} = \frac{6}{15} \neq \frac{2}{5}$$

As $\frac{a_1}{a_2} = \frac{b_1}{b_2} \neq \frac{c_1}{c_2}$, the given equations do not represent a pair of coincident lines.

Sample Question 3 : Is the pair of equations $x + 2y - 3 = 0$ and $6y + 3x - 9 = 0$ consistent? Justify your answer.

Solution : Yes.

Rearranging the terms in the equations, we get

$$x + 2y - 3 = 0$$

$$3x + 6y - 9 = 0$$

Here, $\frac{a_1}{a_2} = \frac{1}{3}$, $\frac{b_1}{b_2} = \frac{1}{3}$, $\frac{c_1}{c_2} = \frac{1}{3}$. As $\frac{a_1}{a_2} = \frac{b_1}{b_2} = \frac{c_1}{c_2}$, the pair of equations is consistent.

EXERCISE 3.2

1. Do the following pair of linear equations have no solution? Justify your answer.

$$(i) \quad \begin{aligned} 2x + 4y &= 3 \\ 12y + 6x &= 6 \end{aligned} \qquad (ii) \quad \begin{aligned} x &= 2y \\ y &= 2x \end{aligned}$$

$$(iii) \quad \begin{aligned} 3x + y - 3 &= 0 \\ 2x + \frac{2}{3}y &= 2 \end{aligned}$$

2. Do the following equations represent a pair of coincident lines? Justify your answer.

$$(i) \quad \begin{aligned} 3x + \frac{1}{7}y &= 3 \\ 7x + 3y &= 7 \end{aligned} \qquad (ii) \quad \begin{aligned} -2x - 3y &= 1 \\ 6y + 4x &= -2 \end{aligned}$$

$$(iii) \quad \begin{aligned} \frac{x}{2} - y - \frac{2}{5} &= 0 \\ 4x + 8y + \frac{5}{16} &= 0 \end{aligned}$$

3. Are the following pair of linear equations consistent? Justify your answer.

$$(i) \quad \begin{aligned} -3x - 4y &= 12 \\ 4y + 3x &= 12 \end{aligned} \qquad (ii) \quad \begin{aligned} \frac{3}{5}x - y &= \frac{1}{2} \\ \frac{1}{5}x - 3y &= \frac{1}{6} \end{aligned}$$

$$(iii) \quad \begin{aligned} 2ax + by &= a \\ 4ax + 2by - 2a &= 0; \quad a, b \neq 0 \end{aligned} \qquad (iv) \quad \begin{aligned} x + 3y &= 11 \\ 2(2x + 6y) &= 22 \end{aligned}$$

4. For the pair of equations

$$\begin{aligned} \lambda x + 3y &= -7 \\ 2x + 6y &= 14 \end{aligned}$$

to have infinitely many solutions, the value of λ should be 1. Is the statement true? Give reasons.

5. For all real values of c , the pair of equations

$$x - 2y = 8$$

$$5x - 10y = c$$

have a unique solution. Justify whether it is true or false.

6. The line represented by $x = 7$ is parallel to the x -axis. Justify whether the statement is true or not.

(D) Short Answer Questions

Sample Question 1 : For which values of p and q , will the following pair of linear equations have infinitely many solutions?

$$4x + 5y = 2$$

$$(2p + 7q)x + (p + 8q)y = 2q - p + 1.$$

Solution :

$$\text{Here, } \frac{a_1}{a_2} = \frac{4}{2p+7q}$$

$$\frac{b_1}{b_2} = \frac{5}{p+8q}$$

$$\frac{c_1}{c_2} = \frac{2}{2q-p+1}$$

For a pair of linear equations to have infinitely many solutions

$$\frac{a_1}{a_2} = \frac{b_1}{b_2} = \frac{c_1}{c_2}$$

$$\text{So, } \frac{4}{2p+7q} = \frac{5}{p+8q} = \frac{2}{2q-p+1}$$

$$\text{So, } \frac{4}{2p+7q} = \frac{5}{p+8q} \text{ and } \frac{4}{2p+7q} = \frac{2}{2q-p+1}$$

$$\text{i.e., } 4p + 32q = 10p + 35q \text{ and } 8q - 4p + 4 = 4p + 14q$$

$$\text{i.e., } 6p + 3q = 0 \quad \text{and } 8p + 6q = 4$$

$$\text{i.e., } q = -2p \quad (1) \quad \text{and } 4p + 3q = 2 \quad (2)$$

Substituting the value of q obtained from Equation(1) in Equation(2), we get

$$4p - 6p = 2$$

$$\text{or } p = -1$$

Substituting the value of p in Equation (1), we get

$$q = 2$$

So, for $p = -1$, $q = 2$, the given pair of linear equations will have infinitely many solutions.

Sample Question 2: Solve the following pair of linear equations:

$$21x + 47y = 110$$

$$47x + 21y = 162$$

Solution: We have

$$21x + 47y = 110 \quad (1)$$

$$47x + 21y = 162 \quad (2)$$

Multiplying Equation (1) by 47 and Equation (2) by 21, we get

$$987x + 2209y = 5170 \quad (3)$$

$$987x + 441y = 3402 \quad (4)$$

Subtracting Equation (4) from Equation (3), we get

$$1768y = 1768$$

$$\text{or } y = 1$$

Substituting the value of y in Equation (1), we get

$$21x + 47 = 110$$

$$\text{or } 21x = 63$$

$$\text{or } x = 3$$

$$\text{So, } x = 3, y = 1$$

Alternative Solution: We have

$$21x + 47y = 110 \quad (1)$$

$$47x + 21y = 162 \quad (2)$$

Adding Equations (1) and (2), we have

$$68x + 68y = 272$$

or $x + y = 4 \quad (5)$

Subtracting Equation (1) from Equation (2), we have

$$26x - 26y = 52$$

or $x - y = 2 \quad (6)$

On adding and subtracting Equations (5) and (6), we get

$$x = 3, \quad y = 1$$

Sample Question 3 : Draw the graphs of the pair of linear equations $x - y + 2 = 0$ and $4x - y - 4 = 0$. Calculate the area of the triangle formed by the lines so drawn and the x -axis.

Solution :

For drawing the graphs of the given equations, we find two solutions of each of the equations, which are given in Table 3.1

Table 3.1

x	0	-2	x	0	1
$y = x + 2$	2	0	$y = 4x - 4$	-4	0

Plot the points A (0, 2), B (-2, 0), P (0, -4) and Q (1, 0) on the graph paper, and join the points to form the lines AB and PQ as shown in Fig 3.1

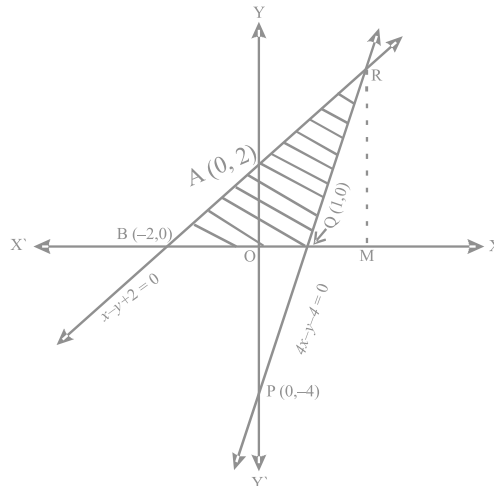

Fig. 3.1

We observe that there is a point R (2, 4) common to both the lines AB and PQ. The triangle formed by these lines and the x - axis is BQR.

The vertices of this triangle are B (-2, 0), Q (1, 0) and R (2, 4).

We know that;

$$\text{Area of triangle} = \frac{1}{2} \text{Base} \times \text{Altitude}$$

Here, Base = BQ = BO + OQ = 2 + 1 = 3 units.

Altitude = RM = Ordinate of R = 4 units.

$$\text{So, area of } \Delta \text{BQR} = \frac{1}{2} \times 3 \times 4 = 6 \text{ sq. units.}$$

EXERCISE 3.3

1. For which value(s) of λ , do the pair of linear equations

$$\lambda x + y = \lambda^2 \text{ and } x + \lambda y = 1 \text{ have}$$

- (i) no solution?
- (ii) infinitely many solutions?
- (iii) a unique solution?

2. For which value(s) of k will the pair of equations

$$kx + 3y = k - 3$$

$$12x + ky = k$$

have no solution?

3. For which values of a and b , will the following pair of linear equations have infinitely many solutions?

$$x + 2y = 1$$

$$(a - b)x + (a + b)y = a + b - 2$$

4. Find the value(s) of p in (i) to (iv) and p and q in (v) for the following pair of equations:

- (i) $3x - y - 5 = 0$ and $6x - 2y - p = 0$,
if the lines represented by these equations are parallel.

- (ii) $-x + py = 1$ and $px - y = 1$,
if the pair of equations has no solution.
- (iii) $-3x + 5y = 7$ and $2px - 3y = 1$,
if the lines represented by these equations are intersecting at a unique point.
- (iv) $2x + 3y - 5 = 0$ and $px - 6y - 8 = 0$,
if the pair of equations has a unique solution.
- (v) $2x + 3y = 7$ and $2px + py = 28 - qy$,
if the pair of equations have infinitely many solutions.
5. Two straight paths are represented by the equations $x - 3y = 2$ and $-2x + 6y = 5$.
Check whether the paths cross each other or not.
6. Write a pair of linear equations which has the unique solution $x = -1, y = 3$. How
many such pairs can you write?
7. If $2x + y = 23$ and $4x - y = 19$, find the values of $5y - 2x$ and $\frac{y}{x} - 2$.
8. Find the values of x and y in the following rectangle [see Fig. 3.2].

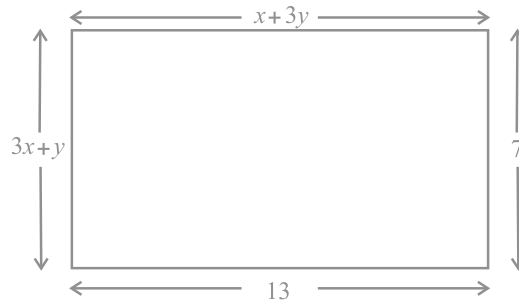

Fig. 3.2

9. Solve the following pairs of equations:

(i) $x + y = 3.3$

$$\frac{0.6}{3x-2y} = -1, \quad 3x-2y \neq 0$$

(ii) $\frac{x}{3} - \frac{y}{4} = 4$

$$\frac{5x}{6} - \frac{y}{8} = 4$$

(iii) $4x + \frac{6}{y} = 15$

$6x - \frac{8}{y} = 14, y \neq 0$

(v) $43x + 67y = -24$

$67x + 43y = 24$

(vii) $\frac{2xy}{x-y} = \frac{3}{2}$

$\frac{xy}{2x-y} = \frac{-3}{10}, \quad x+y \neq 0, 2x-y \neq 0$

(iv) $\frac{1}{2x} - \frac{1}{y} = -1$

$\frac{1}{x} - \frac{1}{2y} = 8, \quad x, y \neq 0$

(vi) $\frac{x}{a} - \frac{y}{b} = a + b$

$\frac{x}{a^2} - \frac{y}{b^2} = 2, \quad a, b \neq 0$

10. Find the solution of the pair of equations $\frac{x}{10} - \frac{y}{5} - 1 = 0$ and $\frac{x}{8} - \frac{y}{6} = 15$.

Hence, find λ , if $y = \lambda x + 5$.

11. By the graphical method, find whether the following pair of equations are consistent or not. If consistent, solve them.

(i) $3x + y + 4 = 0$

$6x - 2y + 4 = 0$

(iii) $x + y = 3$

$3x + 3y = 9$

(ii) $x - 2y = 6$

$3x - 6y = 0$

12. Draw the graph of the pair of equations $2x + y = 4$ and $2x - y = 4$. Write the vertices of the triangle formed by these lines and the y-axis. Also find the area of this triangle.
13. Write an equation of a line passing through the point representing solution of the pair of linear equations $x+y = 2$ and $2x-y = 1$. How many such lines can we find?
14. If $x+1$ is a factor of $2x^3 + ax^2 + 2bx + 1$, then find the values of a and b given that $2a-3b = 4$.
15. The angles of a triangle are x, y and 40° . The difference between the two angles x and y is 30° . Find x and y .

16. Two years ago, Salim was thrice as old as his daughter and six years later, he will be four years older than twice her age. How old are they now?
17. The age of the father is twice the sum of the ages of his two children. After 20 years, his age will be equal to the sum of the ages of his children. Find the age of the father.
18. Two numbers are in the ratio 5 : 6. If 8 is subtracted from each of the numbers, the ratio becomes 4 : 5. Find the numbers.
19. There are some students in the two examination halls A and B. To make the number of students equal in each hall, 10 students are sent from A to B. But if 20 students are sent from B to A, the number of students in A becomes double the number of students in B. Find the number of students in the two halls.
20. A shopkeeper gives books on rent for reading. She takes a fixed charge for the first two days, and an additional charge for each day thereafter. Latika paid Rs 22 for a book kept for six days, while Anand paid Rs 16 for the book kept for four days. Find the fixed charges and the charge for each extra day.
21. In a competitive examination, one mark is awarded for each correct answer while $\frac{1}{2}$ mark is deducted for every wrong answer. Jayanti answered 120 questions and got 90 marks. How many questions did she answer correctly?
22. The angles of a cyclic quadrilateral ABCD are
 $\angle A = (6x + 10)^\circ$, $\angle B = (5x)^\circ$
 $\angle C = (x + y)^\circ$, $\angle D = (3y - 10)^\circ$
Find x and y , and hence the values of the four angles.

(E) Long Answer Questions

Sample Question 1 : Draw the graphs of the lines $x = -2$ and $y = 3$. Write the vertices of the figure formed by these lines, the x -axis and the y -axis. Also, find the area of the figure.

Solution :

We know that the graph of $x = -2$ is a line parallel to y -axis at a distance of 2 units to the left of it.

So, the line l is the graph of $x = -2$ [see Fig. 3.3]

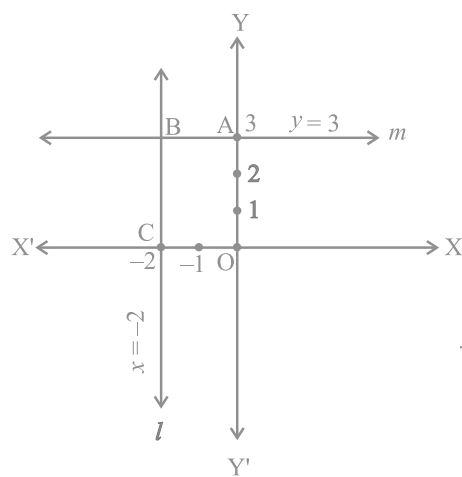

Fig. 3.3

The graph of $y = 3$ is a line parallel to the x -axis at a distance of 3 units above it.

So, the line m is the graph of $y = 3$.

The figure enclosed by the lines $x = -2$, $y = 3$, the x -axis and the y -axis is OABC, which is a rectangle. (Why?)

A is a point on the y -axis at a distance of 3 units above the x -axis. So, the coordinates of A are $(0, 3)$;

C is a point on the x -axis at a distance of 2 units to the left of y -axis. So, the coordinates of C are $(-2, 0)$

B is the solution of the pair of equations $x = -2$ and $y = 3$. So, the coordinates of B are $(-2, 3)$

So, the vertices of the rectangle OABC are O $(0, 0)$, A $(0, 3)$, B $(-2, 3)$, C $(-2, 0)$

The length and breadth of this rectangle are 2 units and 3 units, respectively.

As the area of a rectangle = length \times breadth,

the area of rectangle OABC = $2 \times 3 = 6$ sq. units.

Sample Question 2: Determine, algebraically, the vertices of the triangle formed by the lines

$$5x - y = 5, \quad x + 2y = 1 \quad \text{and} \quad 6x + y = 17.$$

Solution:

The vertex of a triangle is the common solution of the two equations forming its two sides. So, solving the given equations pairwise will give the vertices of the triangle.

From the given equations, we will have the following three pairs of equations:

$$5x - y = 5 \quad \text{and} \quad x + 2y = 1$$

$$x + 2y = 1 \quad \text{and} \quad 6x + y = 17$$

$$5x - y = 5 \quad \text{and} \quad 6x + y = 17$$

Solving the pair of equations

$$5x - y = 5$$

$$x + 2y = 1$$

we get, $x = 1, y = 0$

So, one vertex of the triangle is $(1, 0)$

Solving the second pair of equations

$$x + 2y = 1$$

$$6x + y = 17$$

we get $x = 3, y = -1$

So, another vertex of the triangle is $(3, -1)$

Solving the third pair of equations

$$5x - y = 5$$

$$6x + y = 17,$$

we get $x = 2, y = 5$.

So, the third vertex of the triangle is $(2, 5)$. So, the three vertices of the triangle are $(1, 0), (3, -1)$ and $(2, 5)$.

Sample Question 3 : Jamila sold a table and a chair for Rs 1050, thereby making a profit of 10% on the table and 25% on the chair. If she had taken a profit of 25% on the table and 10% on the chair she would have got Rs 1065. Find the cost price of each.

Solution : Let the cost price of the table be Rs x and the cost price of the chair be Rs y .

The selling price of the table, when it is sold at a profit of 10%

$$= \text{Rs } x + \frac{10}{100}x = \text{Rs } \frac{110}{100}x$$

The selling price of the chair when it is sold at a profit of 25%

$$= \text{Rs } y + \frac{25}{100}y = \text{Rs } \frac{125}{100}y$$

$$\text{So, } \frac{110}{100}x + \frac{125}{100}y = 10500 \quad (1)$$

When the table is sold at a profit of 25%, its selling price =Rs $\left(x + \frac{25}{100}x\right) = \text{Rs } \frac{125}{100}x$

When the chair is sold at a profit of 10%, its selling price =Rs $\left(y + \frac{10}{100}y\right) = \text{Rs } \frac{110}{100}y$

$$\text{So, } \frac{125}{100}x + \frac{110}{100}y = 10650 \quad (2)$$

From Equations (1) and (2), we get

$$110x + 125y = 105000$$

$$\text{and } 125x + 110y = 106500$$

On adding and subtracting these equations, we get

$$235x + 235y = 211500$$

$$\text{and } 15x - 15y = 1500$$

$$\text{i.e., } x + y = 900 \quad (3)$$

$$\text{and } x - y = 100 \quad (4)$$

Solving Equations (3) and (4), we get

$$x = 500, y = 400$$

So, the cost price of the table is Rs 500 and the cost price of the chair is Rs 400.

Sample Question 4: It can take 12 hours to fill a swimming pool using two pipes. If the pipe of larger diameter is used for 4 hours and the pipe of smaller diameter for 9 hours, only half the pool can be filled. How long would it take for each pipe to fill the pool separately?

Solution:

Let the time taken by the pipe of larger diameter to fill the pool be x hours and that taken by the pipe of smaller diameter pipe alone be y hours.

In x hours, the pipe of larger diameter fills the pool.

So, in 1 hour the pipe of larger diameter fills $\frac{1}{x}$ part of the pool, and so, in 4 hours, the pipe of larger diameter fills $\frac{4}{x}$ parts of the pool.

Similarly, in 9 hours, the pipe of smaller diameter fills $\frac{9}{y}$ parts of the pool.

According to the question,

$$\frac{4}{x} + \frac{9}{y} = \frac{1}{2} \quad (1)$$

Also, using both the pipes, the pool is filled in 12 hours.

$$\text{So, } \frac{12}{x} + \frac{12}{y} = 1 \quad (2)$$

Let $\frac{1}{x} = u$ and $\frac{1}{y} = v$. Then Equations (1) and (2) become

$$4u + 9v = \frac{1}{2} \quad (3)$$

$$12u + 12v = 1 \quad (4)$$

Multiplying Equation (3) by 3 and subtracting Equation (4) from it, we get

$$15v = \frac{1}{2} \text{ or } v = \frac{1}{30}$$

Substituting the value of v in Equation (4), we get $u = \frac{1}{20}$

$$\text{So, } u = \frac{1}{20}, v = \frac{1}{30}$$

$$\text{So, } \frac{1}{x} = \frac{1}{20}, \frac{1}{y} = \frac{1}{30}$$

$$\text{or, } x = 20, y = 30.$$

So, the pipe of larger diameter alone can fill the pool in 20 hours and the pipe of smaller diameter alone can fill the pool in 30 hours.

EXERCISE 3.4

1. Graphically, solve the following pair of equations:

$$2x + y = 6$$

$$2x - y + 2 = 0$$

Find the ratio of the areas of the two triangles formed by the lines representing these equations with the x -axis and the lines with the y -axis.

2. Determine, graphically, the vertices of the triangle formed by the lines

$$y = x, \quad 3y = x, \quad x + y = 8$$

3. Draw the graphs of the equations $x = 3$, $x = 5$ and $2x - y - 4 = 0$. Also find the area of the quadrilateral formed by the lines and the x -axis.

4. The cost of 4 pens and 4 pencil boxes is Rs 100. Three times the cost of a pen is Rs 15 more than the cost of a pencil box. Form the pair of linear equations for the above situation. Find the cost of a pen and a pencil box.

5. Determine, algebraically, the vertices of the triangle formed by the lines

$$3x - y = 3$$

$$2x - 3y = 2$$

$$x + 2y = 8$$

6. Ankita travels 14 km to her home partly by rickshaw and partly by bus. She takes half an hour if she travels 2 km by rickshaw, and the remaining distance by bus.

On the other hand, if she travels 4 km by rickshaw and the remaining distance by bus, she takes 9 minutes longer. Find the speed of the rickshaw and of the bus.

7. A person, rowing at the rate of 5 km/h in still water, takes thrice as much time in going 40 km upstream as in going 40 km downstream. Find the speed of the stream.
8. A motor boat can travel 30 km upstream and 28 km downstream in 7 hours. It can travel 21 km upstream and return in 5 hours. Find the speed of the boat in still water and the speed of the stream.
9. A two-digit number is obtained by either multiplying the sum of the digits by 8 and then subtracting 5 or by multiplying the difference of the digits by 16 and then adding 3. Find the number.
10. A railway half ticket costs half the full fare, but the reservation charges are the same on a half ticket as on a full ticket. One reserved first class ticket from the station A to B costs Rs 2530. Also, one reserved first class ticket and one reserved first class half ticket from A to B costs Rs 3810. Find the full first class fare from station A to B, and also the reservation charges for a ticket.
11. A shopkeeper sells a saree at 8% profit and a sweater at 10% discount, thereby, getting a sum Rs 1008. If she had sold the saree at 10% profit and the sweater at 8% discount, she would have got Rs 1028. Find the cost price of the saree and the list price (price before discount) of the sweater.
12. Susan invested certain amount of money in two schemes A and B, which offer interest at the rate of 8% per annum and 9% per annum, respectively. She received Rs 1860 as annual interest. However, had she interchanged the amount of investments in the two schemes, she would have received Rs 20 more as annual interest. How much money did she invest in each scheme?
13. Vijay had some bananas, and he divided them into two lots A and B. He sold the first lot at the rate of Rs 2 for 3 bananas and the second lot at the rate of Re 1 per banana, and got a total of Rs 400. If he had sold the first lot at the rate of Re 1 per banana, and the second lot at the rate of Rs 4 for 5 bananas, his total collection would have been Rs 460. Find the total number of bananas he had.

QUADRATIC EQUATIONS

(A) Main Concepts and Results

- Quadratic equation : A quadratic equation in the variable x is of the form $ax^2 + bx + c = 0$, where a, b, c are real numbers and $a \neq 0$.
- Roots of a quadratic equation : A real number α is said to be a root of the quadratic equation $ax^2 + bx + c = 0$, if $a\alpha^2 + b\alpha + c = 0$.
- The roots of the quadratic equation $ax^2 + bx + c = 0$ are the same as the zeroes of the quadratic polynomial $ax^2 + bx + c$.
- Finding the roots of a quadratic equation by the method of factorisation : If we can factorise the quadratic polynomial $ax^2 + bx + c$, then the roots of the quadratic equation $ax^2 + bx + c = 0$ can be found by equating to zero the linear factors of $ax^2 + bx + c$.
- Finding the roots of a quadratic equation by the method of completing the square : By adding and subtracting a suitable constant, we club the x^2 and x terms in the quadratic equation so that they become a complete square, and solve for x .
- Quadratic Formula : If $b^2 - 4ac \geq 0$, then the real roots of the quadratic equation $ax^2 + bx + c = 0$ are given by $\frac{-b \pm \sqrt{b^2 - 4ac}}{2a}$.
- The expression $b^2 - 4ac$ is called the discriminant of the quadratic equation.
- Existence of roots of a quadratic equation: A quadratic equation $ax^2 + bx + c = 0$ has

- (i) two distinct real roots if $b^2 - 4ac > 0$
- (ii) two equal real roots if $b^2 - 4ac = 0$
- (iii) no real roots if $b^2 - 4ac < 0$.

(B) Multiple Choice Questions

Choose the correct answer from the given four options:

Sample Question 1 : Which one of the following is not a quadratic equation?

- (A) $(x + 2)^2 = 2(x + 3)$
- (B) $x^2 + 3x = (-1)(1 - 3x)^2$
- (C) $(x + 2)(x - 1) = x^2 - 2x - 3$
- (D) $x^3 - x^2 + 2x + 1 = (x + 1)^3$

Solution : Answer (C)

Sample Question 2 : Which constant should be added and subtracted to solve the quadratic equation $4x^2 - \sqrt{3}x - 5 = 0$ by the method of completing the square?

- (A) $\frac{9}{16}$
- (B) $\frac{3}{16}$
- (C) $\frac{3}{4}$
- (D) $\frac{\sqrt{3}}{4}$

Solution : Answer (B)

EXERCISE 4.1

Choose the correct answer from the given four options in the following questions:

1. Which of the following is a quadratic equation?

- (A) $x^2 + 2x + 1 = (4 - x)^2 + 3$
- (B) $-2x^2 = (5 - x) \left(2x - \frac{2}{5} \right)$
- (C) $(k + 1)x^2 + \frac{3}{2}x = 7$, where $k = -1$
- (D) $x^3 - x^2 = (x - 1)^3$

2. Which of the following is not a quadratic equation?

- (A) $2(x - 1)^2 = 4x^2 - 2x + 1$
- (B) $2x - x^2 = x^2 + 5$
- (C) $(\sqrt{2}x - \sqrt{3})^2 - x^2 - 3x^2 - 5x$
- (D) $(x^2 + 2x)^2 = x^4 + 3 + 4x^3$

3. Which of the following equations has 2 as a root?

- (A) $x^2 - 4x + 5 = 0$
- (B) $x^2 + 3x - 12 = 0$
- (C) $2x^2 - 7x + 6 = 0$
- (D) $3x^2 - 6x - 2 = 0$

4. If $\frac{1}{2}$ is a root of the equation $x^2 + kx - \frac{5}{4} = 0$, then the value of k is
- (A) 2 (B) -2 (C) $\frac{1}{4}$ (D) $\frac{1}{2}$
5. Which of the following equations has the sum of its roots as 3?
- (A) $2x^2 - 3x + 6 = 0$ (B) $-x^2 + 3x - 3 = 0$
- (C) $\sqrt{2}x^2 - \frac{3}{\sqrt{2}}x - 1 = 0$ (D) $3x^2 - 3x + 3 = 0$
6. Values of k for which the quadratic equation $2x^2 - kx + k = 0$ has equal roots is
- (A) 0 only (B) 4 (C) 8 only (D) 0, 8
7. Which constant must be added and subtracted to solve the quadratic equation $9x^2 + \frac{3}{4}x - \sqrt{2} = 0$ by the method of completing the square?
- (A) $\frac{1}{8}$ (B) $\frac{1}{64}$ (C) $\frac{1}{4}$ (D) $\frac{9}{64}$
8. The quadratic equation $2x^2 - \sqrt{5}x + 1 = 0$ has
- (A) two distinct real roots (B) two equal real roots
- (C) no real roots (D) more than 2 real roots
9. Which of the following equations has two distinct real roots?
- (A) $2x^2 - 3\sqrt{2}x - \frac{9}{4} = 0$ (B) $x^2 + x - 5 = 0$
- (C) $x^2 + 3x + 2\sqrt{2} = 0$ (D) $5x^2 - 3x + 1 = 0$
10. Which of the following equations has no real roots?
- (A) $x^2 - 4x + 3\sqrt{2} = 0$ (B) $x^2 + 4x - 3\sqrt{2} = 0$
- (C) $x^2 - 4x - 3\sqrt{2} = 0$ (D) $3x^2 + 4\sqrt{3}x + 4 = 0$

11. $(x^2 + 1)^2 - x^2 = 0$ has
- (A) four real roots (B) two real roots
 (C) no real roots (D) one real root.

(C) Short Answer Questions with Reasoning

Sample Question 1 : Does $(x - 1)^2 + 2(x + 1) = 0$ have a real root? Justify your answer.

Solution : No, since the equation is simplified to $x^2 + 3 = 0$ whose discriminant is -12 .

Sample Question 2 : Is the following statement 'True' or 'False'? Justify your answer. If in a quadratic equation the coefficient of x is zero, then the quadratic equation has no real roots.

Solution : False, since the discriminant in this case is $-4ac$ which can still be non-negative if a and c are of opposite signs or if one of a or c is zero.

EXERCISE 4.2

1. State whether the following quadratic equations have two distinct real roots. Justify your answer.

(i) $x^2 - 3x + 4 = 0$

(ii) $2x^2 + x - 1 = 0$

(iii) $2x^2 - 6x + \frac{9}{2} = 0$

(iv) $3x^2 - 4x + 1 = 0$

(v) $(x + 4)^2 - 8x = 0$

(vi) $(x - \sqrt{2})^2 - 2(x + 1) = 0$

(vii) $\sqrt{2}x^2 - \frac{3}{\sqrt{2}}x - \frac{1}{\sqrt{2}} = 0$

(viii) $x(1 - x) - 2 = 0$

(ix) $(x - 1)(x + 2) + 2 = 0$

(x) $(x + 1)(x - 2) + x = 0$

2. Write whether the following statements are true or false. Justify your answers.
- (i) Every quadratic equation has exactly one root.
 (ii) Every quadratic equation has at least one real root.
 (iii) Every quadratic equation has at least two roots.
 (iv) Every quadratic equations has at most two roots.
 (v) If the coefficient of x^2 and the constant term of a quadratic equation have opposite signs, then the quadratic equation has real roots.

- (vi) If the coefficient of x^2 and the constant term have the same sign and if the coefficient of x term is zero, then the quadratic equation has no real roots.
3. A quadratic equation with integral coefficient has integral roots. Justify your answer.
 4. Does there exist a quadratic equation whose coefficients are rational but both of its roots are irrational? Justify your answer.
 5. Does there exist a quadratic equation whose coefficients are all distinct irrationals but both the roots are rationals? Why?
 6. Is 0.2 a root of the equation $x^2 - 0.4 = 0$? Justify.
 7. If $b = 0, c < 0$, is it true that the roots of $x^2 + bx + c = 0$ are numerically equal and opposite in sign? Justify.

(D) Short Answer Questions

Sample Question 1 : Find the roots of the quadratic equation $2x^2 - \sqrt{5}x - 2 = 0$ using the quadratic formula.

Solution : $b^2 - 4ac = 5 - 4 \times 2 \times (-2) = 21$

Therefore, the roots are $\frac{\sqrt{5} \pm \sqrt{21}}{4}$, i.e., $\frac{\sqrt{5} + \sqrt{21}}{4}$ and $\frac{\sqrt{5} - \sqrt{21}}{4}$

Sample Question 2 : Find the roots of $6x^2 - \sqrt{2}x - 2 = 0$ by the factorisation of the corresponding quadratic polynomial.

Solution :

$$\begin{aligned} 6x^2 - \sqrt{2}x - 2 &= 6x^2 - 3\sqrt{2}x + 2\sqrt{2}x - 2 \\ &= 3x(2x - \sqrt{2}) + \sqrt{2}(2x - \sqrt{2}) \\ &= (3x + \sqrt{2})(2x - \sqrt{2}) \end{aligned}$$

Now, $6x^2 - \sqrt{2}x - 2 = 0$ gives $(3x + \sqrt{2})(2x - \sqrt{2}) = 0$, i.e., $3x + \sqrt{2} = 0$ or $2x - \sqrt{2} = 0$

So, the roots are $-\frac{\sqrt{2}}{3}$ and $\frac{\sqrt{2}}{2}$.

EXERCISE 4.3

1. Find the roots of the quadratic equations by using the quadratic formula in each of the following:

(i) $2x^2 - 3x - 5 = 0$

(ii) $5x^2 + 13x + 8 = 0$

(iii) $-3x^2 + 5x + 12 = 0$

(iv) $-x^2 + 7x - 10 = 0$

(v) $x^2 + 2\sqrt{2}x - 6 = 0$

(vi) $x^2 - 3\sqrt{5}x + 10 = 0$

(vii) $\frac{1}{2}x^2 - \sqrt{11}x + 1 = 0$

2. Find the roots of the following quadratic equations by the factorisation method:

(i) $2x^2 + \frac{5}{3}x - 2 = 0$

(ii) $\frac{2}{5}x^2 - x - \frac{3}{5} = 0$

(iii) $3\sqrt{2}x^2 - 5x - \sqrt{2} = 0$

(iv) $3x^2 + 5\sqrt{5}x - 10 = 0$

(v) $21x^2 - 2x + \frac{1}{21} = 0$

(E) Long Answer Questions

Sample Question 1 : Check whether the equation $6x^2 - 7x + 2 = 0$ has real roots, and if it has, find them by the method of completing the squares.

Solution : The discriminant $= b^2 - 4ac = 49 - 4 \times 6 \times 2 = 1 > 0$

So, the given equation has two distinct real roots.

Now, $6x^2 - 7x + 2 = 0$

i.e., $36x^2 - 42x + 12 = 0$

i.e., $6x - \frac{7}{2} + 12 - \frac{49}{4} = 0$

i.e., $6x - \frac{7}{2} - \frac{1}{2} = 0$ or $\left(6x - \frac{7}{2}\right)^2 = \left(\frac{1}{2}\right)^2$

The roots are given by $6x = \frac{7}{2}, \frac{1}{2}$

i.e., $6x = 4, 3$

i.e., $x = \frac{2}{3}, \frac{1}{2}$.

Sample Question 2 : Had Ajita scored 10 more marks in her mathematics test out of 30 marks, 9 times these marks would have been the square of her actual marks. How many marks did she get in the test?

Solution : Let her actual marks be x

Therefore, $9(x+10) = x^2$

i.e., $x^2 - 9x - 90 = 0$

i.e., $x^2 - 15x + 6x - 90 = 0$

i.e., $x(x-15) + 6(x-15) = 0$

i.e., $(x+6)(x-15) = 0$

Therefore, $x = -6$ or $x = 15$

Since x is the marks obtained, $x \neq -6$. Therefore, $x = 15$.

So, Ajita got 15 marks in her mathematics test.

Sample Question 3 : A train travels at a certain average speed for a distance of 63 km and then travels a distance of 72 km at an average speed of 6 km/h more than its original speed. If it takes 3 hours to complete the total journey, what is its original average speed?

Solution : Let its original average speed be x km/h. Therefore,

$$\frac{63}{x} + \frac{72}{x+6} = 3$$

i.e., $\frac{7}{x} + \frac{8}{x+6} = \frac{3}{9} = \frac{1}{3}$

i.e., $\frac{7(x+6)+8x}{x(x+6)} = \frac{1}{3}$

$$\text{i.e., } 21(x+6) + 24x = x(x+6)$$

$$\text{i.e., } 21x + 126 + 24x = x^2 + 6x$$

$$\text{i.e., } x^2 - 39x - 126 = 0$$

$$\text{i.e., } (x+3)(x-42) = 0$$

$$\text{i.e., } x = -3 \text{ or } x = 42$$

Since x is the average speed of the train, x cannot be negative.

Therefore, $x = 42$.

So, the original average speed of the train is 42 km/h.

EXERCISE 4.4

- Find whether the following equations have real roots. If real roots exist, find them.
 - $8x^2 + 2x - 3 = 0$
 - $-2x^2 + 3x + 2 = 0$
 - $5x^2 - 2x - 10 = 0$
 - $\frac{1}{2x-3} + \frac{1}{x-5} = 1, x \neq \frac{3}{2}, 5$
 - $x^2 + 5\sqrt{5}x - 70 = 0$
- Find a natural number whose square diminished by 84 is equal to thrice of 8 more than the given number.
- A natural number, when increased by 12, equals 160 times its reciprocal. Find the number.
- A train, travelling at a uniform speed for 360 km, would have taken 48 minutes less to travel the same distance if its speed were 5 km/h more. Find the original speed of the train.
- If Zeba were younger by 5 years than what she really is, then the square of her age (in years) would have been 11 more than five times her actual age. What is her age now?
- At present Asha's age (in years) is 2 more than the square of her daughter Nisha's age. When Nisha grows to her mother's present age, Asha's age would be one year less than 10 times the present age of Nisha. Find the present ages of both Asha and Nisha.

7. In the centre of a rectangular lawn of dimensions $50\text{ m} \times 40\text{ m}$, a rectangular pond has to be constructed so that the area of the grass surrounding the pond would be 1184 m^2 [see Fig. 4.1]. Find the length and breadth of the pond.

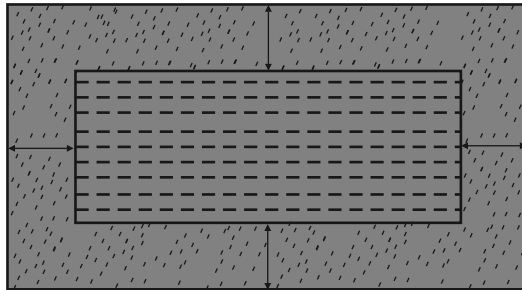

Fig. 4.1

8. At t minutes past 2 pm, the time needed by the minutes hand of a clock to show 3 pm was found to be 3 minutes less than $\frac{t^2}{4}$ minutes. Find t .

ARITHMETIC PROGRESSIONS

(A) Main Concepts and Results

- An arithmetic progression (AP) is a list of numbers in which each term is obtained by adding a fixed number d to the preceding term, except the first term a . The fixed number d is called its common difference.

The general form of an AP is $a, a + d, a + 2d, a + 3d, \dots$

- In the list of numbers a_1, a_2, a_3, \dots if the differences $a_2 - a_1, a_3 - a_2, a_4 - a_3, \dots$ give the same value, i.e., if $a_{k+1} - a_k$ is the same for different values of k , then the given list of numbers is an AP.
- The n^{th} term a_n (or the general term) of an AP is $a_n = a + (n - 1) d$, where a is the first term and d is the common difference. Note that $a_1 = a$.
- The sum S_n of the first n terms of an AP is given by

$$S_n = \frac{n}{2} [2a + (n - 1) d]$$

If l is the last term of an AP of n terms, then the sum of all the terms can also be given by

$$S_n = \frac{n}{2} [a + l]$$

Sometimes S_n is also denoted by S .

- If S_n is the sum of the first n terms of an AP, then its n^{th} term a_n is given by

$$a_n = S_n - S_{n-1}$$

(B) Multiple Choice Questions

Choose the correct answer from the given four options:

Sample Question 1 : The 10th term of the AP: 5, 8, 11, 14, ... is

- (A) 32 (B) 35 (C) 38 (D) 185

Solution : Answer (A)

Sample Question 2 : In an AP if $a = -7.2$, $d = 3.6$, $a_n = 7.2$, then n is

- (A) 1 (B) 3 (C) 4 (D) 5

Solution : Answer (D)

EXERCISE 5.1

Choose the correct answer from the given four options:

- In an AP, if $d = -4$, $n = 7$, $a_n = 4$, then a is
 (A) 6 (B) 7 (C) 20 (D) 28
- In an AP, if $a = 3.5$, $d = 0$, $n = 101$, then a_n will be
 (A) 0 (B) 3.5 (C) 103.5 (D) 104.5
- The list of numbers $-10, -6, -2, 2, \dots$ is
 (A) an AP with $d = -16$
 (B) an AP with $d = 4$
 (C) an AP with $d = -4$
 (D) not an AP
- The 11th term of the AP: $-5, \frac{-5}{2}, 0, \frac{5}{2}, \dots$ is
 (A) -20 (B) 20 (C) -30 (D) 30
- The first four terms of an AP, whose first term is -2 and the common difference is -2 , are

- (A) $-2, 0, 2, 4$
(B) $-2, 4, -8, 16$
(C) $-2, -4, -6, -8$
(D) $-2, -4, -8, -16$
6. The 21st term of the AP whose first two terms are -3 and 4 is
(A) 17 (B) 137 (C) 143 (D) -143
7. If the 2nd term of an AP is 13 and the 5th term is 25 , what is its 7th term?
(A) 30 (B) 33 (C) 37 (D) 38
8. Which term of the AP: $21, 42, 63, 84, \dots$ is 210 ?
(A) 9th (B) 10th (C) 11th (D) 12th
9. If the common difference of an AP is 5 , then what is $a_{18} - a_{13}$?
(A) 5 (B) 20 (C) 25 (D) 30
10. What is the common difference of an AP in which $a_{18} - a_{14} = 32$?
(A) 8 (B) -8 (C) -4 (D) 4
11. Two APs have the same common difference. The first term of one of these is -1 and that of the other is -8 . Then the difference between their 4th terms is
(A) -1 (B) -8 (C) 7 (D) -9
12. If 7 times the 7th term of an AP is equal to 11 times its 11th term, then its 18th term will be
(A) 7 (B) 11 (C) 18 (D) 0
13. The 4th term from the end of the AP: $-11, -8, -5, \dots, 49$ is
(A) 37 (B) 40 (C) 43 (D) 58
14. The famous mathematician associated with finding the sum of the first 100 natural numbers is
(A) Pythagoras (B) Newton
(C) Gauss (D) Euclid
15. If the first term of an AP is -5 and the common difference is 2 , then the sum of the first 6 terms is
(A) 0 (B) 5 (C) 6 (D) 15

- 16.** The sum of first 16 terms of the AP: 10, 6, 2,... is
(A) -320 (B) 320 (C) -352 (D) -400
- 17.** In an AP if $a = 1$, $a_n = 20$ and $S_n = 399$, then n is
(A) 19 (B) 21 (C) 38 (D) 42
- 18.** The sum of first five multiples of 3 is
(A) 45 (B) 55 (C) 65 (D) 75

(C) Short Answer Questions with Reasoning

Sample Question 1: In the AP: 10, 5, 0, -5, ... the common difference d is equal to 5. Justify whether the above statement is true or false.

Solution :

$$a_2 - a_1 = 5 - 10 = -5$$

$$a_3 - a_2 = 0 - 5 = -5$$

$$a_4 - a_3 = -5 - 0 = -5$$

Although the given list of numbers forms an AP, it is with $d = -5$ and not with $d = 5$

So, the given statement is false.

Sample Question 2 : Divya deposited Rs 1000 at compound interest at the rate of 10% per annum. The amounts at the end of first year, second year, third year, ..., form an AP. Justify your answer.

Solution : Amount at the end of the 1st year = Rs 1100

Amount at the end of the 2nd year = Rs 1210

Amount at the end of 3rd year = Rs 1331 and so on.

So, the amount (in Rs) at the end of 1st year, 2nd year, 3rd year, ... are

1100, 1210, 1331, ...

Here, $a_2 - a_1 = 110$

$a_3 - a_2 = 121$

As, $a_2 - a_1 \neq a_3 - a_2$, it does not form an AP.

Sample Question 3: The n^{th} term of an AP cannot be $n^2 + 1$. Justify your answer.

Solution :

$$\text{Here, } a_n = n^2 + 1$$

$$\text{So, } a_1 = 1^2 + 1 = 2$$

$$a_2 = 2^2 + 1 = 5$$

$$a_3 = 3^2 + 1 = 10$$

⋮

List of numbers becomes 2, 5, 10, ...

Here, $5 - 2 \neq 10 - 5$, so it does not form an AP.

Alternative Solution 1:

We know that in an AP, $d = a_n - a_{n-1}$

$$\text{Here, } a_n = n^2 + 1$$

$$\begin{aligned} \text{So, } a_n - a_{n-1} &= (n^2 + 1) - (n-1)^2 + 1 \\ &= 2n - 1 \end{aligned}$$

As $a_n - a_{n-1}$ depends upon n , d is not a fixed number.

So, $a_n = n^2 + 1$ cannot be the n^{th} term of an AP.

Alternative Solution 2:

We know that in an AP

$a_n = a + (n-1)d$. We observe that a_n is a linear polynomial in n .

Here, $a_n = n^2 + 1$ is not a linear polynomial in n . So, it cannot be the n^{th} term of an AP.

EXERCISE 5.2

1. Which of the following form an AP? Justify your answer.
 - (i) $-1, -1, -1, -1, \dots$
 - (ii) $0, 2, 0, 2, \dots$
 - (iii) $1, 1, 2, 2, 3, 3, \dots$
 - (iv) $11, 22, 33, \dots$
 - (v) $\frac{1}{2}, \frac{1}{3}, \frac{1}{4}, \dots$
 - (vi) $2, 2^2, 2^3, 2^4, \dots$
 - (vii) $\sqrt{3}, \sqrt{12}, \sqrt{27}, \sqrt{48}, \dots$
2. Justify whether it is true to say that $-1, -\frac{3}{2}, -2, \frac{5}{2}, \dots$ forms an AP as $a_2 - a_1 = a_3 - a_2$.
3. For the AP: $-3, -7, -11, \dots$, can we find directly $a_{30} - a_{20}$ without actually finding a_{30} and a_{20} ? Give reasons for your answer.
4. Two APs have the same common difference. The first term of one AP is 2 and that of the other is 7. The difference between their 10th terms is the same as the difference between their 21st terms, which is the same as the difference between any two corresponding terms. Why?
5. Is 0 a term of the AP: $31, 28, 25, \dots$? Justify your answer.
6. The taxi fare after each km, when the fare is Rs 15 for the first km and Rs 8 for each additional km, does not form an AP as the total fare (in Rs) after each km is
$$15, 8, 8, 8, \dots$$
Is the statement true? Give reasons.
7. In which of the following situations, do the lists of numbers involved form an AP? Give reasons for your answers.
 - (i) The fee charged from a student every month by a school for the whole session, when the monthly fee is Rs 400.

- (ii) The fee charged every month by a school from Classes I to XII, when the monthly fee for Class I is Rs 250, and it increases by Rs 50 for the next higher class.
- (iii) The amount of money in the account of Varun at the end of every year when Rs 1000 is deposited at simple interest of 10% per annum.
- (iv) The number of bacteria in a certain food item after each second, when they double in every second.

8. Justify whether it is true to say that the following are the n^{th} terms of an AP.

- (i) $2n-3$
- (ii) $3n^2+5$
- (iii) $1+n+n^2$

(D) Short Answer Questions

Sample Question 1 : If the numbers $n - 2$, $4n - 1$ and $5n + 2$ are in AP, find the value of n .

Solution :

As $n - 2$, $4n - 1$, $5n + 2$ are in AP,

$$\text{so } (4n - 1) - (n - 2) = (5n + 2) - (4n - 1)$$

$$\text{i.e., } 3n + 1 = n + 3$$

$$\text{i.e., } n = 1$$

Sample Question 2 : Find the value of the middle most term (s) of the AP : $-11, -7, -3, \dots, 49$.

Solution :

$$\text{Here, } a = -11, \quad d = -7 - (-11) = 4, \quad a_n = 49$$

$$\text{We have } a_n = a + (n - 1) d$$

$$\text{So, } 49 = -11 + (n - 1) \times 4$$

$$\text{i.e., } 60 = (n - 1) \times 4$$

$$\text{i.e., } n = 16$$

As n is an even number, there will be two middle terms which are

$\frac{16}{2}$ th and $\left(\frac{16}{2}+1\right)$ th, i.e., the 8th term and the 9th term.

$$a_8 = a + 7d = -11 + 7 \times 4 = 17$$

$$a_9 = a + 8d = -11 + 8 \times 4 = 21$$

So, the values of the two middle most terms are 17 and 21, respectively.

Sample Question 3: The sum of the first three terms of an AP is 33. If the product of the first and the third term exceeds the second term by 29, find the AP.

Solution : Let the three terms in AP be

$$a - d, a, a + d.$$

So, $a - d + a + a + d = 33$

or $a = 11$

Also, $(a - d)(a + d) = a + 29$

i.e., $a^2 - d^2 = a + 29$

i.e., $121 - d^2 = 11 + 29$

i.e., $d^2 = 81$

i.e., $d = \pm 9$

So there will be two APs and they are : 2, 11, 20, ...

and 20, 11, 2, ...

EXERCISE 5.3

1. Match the APs given in column A with suitable common differences given in column B.

Column A

(A₁) 2, -2, -6, -10, ...

(A₂) $a = -18, n = 10, a_n = 0$

(A₃) $a = 0, a_{10} = 6$

(A₄) $a_2 = 13, a_4 = 3$

Column B

(B₁) $\frac{2}{3}$

(B₂) -5

(B₃) 4

(B₄) -4

(B₅) 2

(B₆) $\frac{1}{2}$

(B₇) 5

2. Verify that each of the following is an AP, and then write its next three terms.

(i) $0, \frac{1}{4}, \frac{1}{2}, \frac{3}{4}, \dots$

(ii) $5, \frac{14}{3}, \frac{13}{3}, 4, \dots$

(iii) $\sqrt{3}, 2\sqrt{3}, 3\sqrt{3}, \dots$

(iv) $a + b, (a + 1) + b, (a + 1) + (b + 1), \dots$

(v) $a, 2a + 1, 3a + 2, 4a + 3, \dots$

3. Write the first three terms of the APs when a and d are as given below:

(i) $a = \frac{1}{2}, d = -\frac{1}{6}$

(ii) $a = -5, d = -3$

(iii) $a = \sqrt{2}, d = \frac{1}{\sqrt{2}}$

4. Find a, b and c such that the following numbers are in AP: $a, 7, b, 23, c$.

5. Determine the AP whose fifth term is 19 and the difference of the eighth term from the thirteenth term is 20.

6. The 26th, 11th and the last term of an AP are 0, 3 and $-\frac{1}{5}$, respectively. Find the common difference and the number of terms.

7. The sum of the 5th and the 7th terms of an AP is 52 and the 10th term is 46. Find the AP.

8. Find the 20th term of the AP whose 7th term is 24 less than the 11th term, first term being 12.

9. If the 9th term of an AP is zero, prove that its 29th term is twice its 19th term.

10. Find whether 55 is a term of the AP: 7, 10, 13, --- or not. If yes, find which term it is.

11. Determine k so that $k^2 + 4k + 8$, $2k^2 + 3k + 6$, $3k^2 + 4k + 4$ are three consecutive terms of an AP.
12. Split 207 into three parts such that these are in AP and the product of the two smaller parts is 4623.
13. The angles of a triangle are in AP. The greatest angle is twice the least. Find all the angles of the triangle.
14. If the n th terms of the two APs: 9, 7, 5, ... and 24, 21, 18, ... are the same, find the value of n . Also find that term.
15. If sum of the 3rd and the 8th terms of an AP is 7 and the sum of the 7th and the 14th terms is -3 , find the 10th term.
16. Find the 12th term from the end of the AP: $-2, -4, -6, \dots, -100$.
17. Which term of the AP: 53, 48, 43, ... is the first negative term?
18. How many numbers lie between 10 and 300, which when divided by 4 leave a remainder 3?
19. Find the sum of the two middle most terms of the AP: $-\frac{4}{3}, -1, -\frac{2}{3}, \dots, 4\frac{1}{3}$.
20. The first term of an AP is -5 and the last term is 45. If the sum of the terms of the AP is 120, then find the number of terms and the common difference.
21. Find the sum:
- (i) $1 + (-2) + (-5) + (-8) + \dots + (-236)$
- (ii) $4 - \frac{1}{n} + 4 - \frac{2}{n} + 4 - \frac{3}{n} + \dots$ upto n terms
- (iii) $\frac{a-b}{a+b} + \frac{3a-2b}{a+b} + \frac{5a-3b}{a+b} + \dots$ to 11 terms.
22. Which term of the AP: $-2, -7, -12, \dots$ will be -77 ? Find the sum of this AP upto the term -77 .
23. If $a_n = 3 - 4n$, show that a_1, a_2, a_3, \dots form an AP. Also find S_{20} .
24. In an AP, if $S_n = n(4n + 1)$, find the AP.

25. In an AP, if $S_n = 3n^2 + 5n$ and $a_k = 164$, find the value of k .
26. If S_n denotes the sum of first n terms of an AP, prove that
- $$S_{12} = 3(S_8 - S_4)$$
27. Find the sum of first 17 terms of an AP whose 4th and 9th terms are -15 and -30 respectively.
28. If sum of first 6 terms of an AP is 36 and that of the first 16 terms is 256, find the sum of first 10 terms.
29. Find the sum of all the 11 terms of an AP whose middle most term is 30.
30. Find the sum of last ten terms of the AP: 8, 10, 12, ---, 126.
31. Find the sum of first seven numbers which are multiples of 2 as well as of 9.
[Hint: Take the LCM of 2 and 9]
32. How many terms of the AP: $-15, -13, -11, \dots$ are needed to make the sum -55 ? Explain the reason for double answer.
33. The sum of the first n terms of an AP whose first term is 8 and the common difference is 20 is equal to the sum of first $2n$ terms of another AP whose first term is -30 and the common difference is 8. Find n .
34. Kanika was given her pocket money on Jan 1st, 2008. She puts Re 1 on Day 1, Rs 2 on Day 2, Rs 3 on Day 3, and continued doing so till the end of the month, from this money into her piggy bank. She also spent Rs 204 of her pocket money, and found that at the end of the month she still had Rs 100 with her. How much was her pocket money for the month?
35. Yasmeen saves Rs 32 during the first month, Rs 36 in the second month and Rs 40 in the third month. If she continues to save in this manner, in how many months will she save Rs 2000?

(E) Long Answer Questions

Sample Question 1: The sum of four consecutive numbers in an AP is 32 and the ratio of the product of the first and the last terms to the product of the two middle terms is 7 : 15. Find the numbers.

Solution: Let the four consecutive numbers in AP be

$$a - 3d, a - d, a + d, a + 3d.$$

$$\begin{aligned} \text{So, } a - 3d + a - d + a + d + a + 3d &= 32 \\ \text{or } 4a &= 32 \\ \text{or } a &= 8 \end{aligned}$$

$$\text{Also, } \frac{a-3d}{a-d} \cdot \frac{a}{a} \cdot \frac{3d}{d} = \frac{7}{15}$$

$$\text{or, } \frac{a^2 - 9d^2}{a^2 - d^2} = \frac{7}{15}$$

$$\text{or, } 15a^2 - 135d^2 = 7a^2 - 7d^2$$

$$\text{or, } 8a^2 - 128d^2 = 0$$

$$\text{or, } d^2 = \frac{8}{128} \cdot \frac{8}{4}$$

$$\text{or, } d = \pm 2$$

So, when $a = 8$, $d = 2$, the numbers are 2, 6, 10, 14.

Sample Question 2: Solve the equation :

$$1 + 4 + 7 + 10 + \dots + x = 287$$

Solution :

Here, 1, 4, 7, 10, ..., x form an AP with $a = 1$, $d = 3$, $a_n = x$

We have, $a_n = a + (n - 1)d$

$$\text{So, } x = 1 + (n - 1) \times 3 = 3n - 2$$

$$\text{Also, } S = \frac{n}{2}(a + l)$$

$$\text{So, } 287 = \frac{n}{2}(1 + x)$$

$$= \frac{n}{2}(1 + 3n - 2)$$

$$\text{or, } 574 = n(3n - 1)$$

$$\text{or, } 3n^2 - n - 574 = 0$$

$$\begin{aligned} \text{Therefore, } n &= \frac{1 \pm \sqrt{1 + 6888}}{6} \\ &= \frac{1 \pm 83}{6} = \frac{84}{6}, \frac{-82}{6} \\ &= 14, \frac{-41}{3} \end{aligned}$$

As n cannot be negative, so $n = 14$

Therefore, $x = 3n - 2 = 3 \times 14 - 2 = 40$.

Alternative solution:

Here, 1, 4, 7, 10, ... x form an AP with $a = 1$, $d = 3$, $S = 287$

$$\text{We have, } S = \frac{n}{2} [2a + (n-1)d]$$

$$\text{So, } 287 = \frac{n}{2} [2 + (n-1) \cdot 3]$$

$$\text{or, } 574 = n(3n - 1)$$

$$\text{or, } 3n^2 - n - 574 = 0$$

Now proceed as above.

EXERCISE 5.4

1. The sum of the first five terms of an AP and the sum of the first seven terms of the same AP is 167. If the sum of the first ten terms of this AP is 235, find the sum of its first twenty terms.

2. Find the

- (i) sum of those integers between 1 and 500 which are multiples of 2 as well as of 5.
- (ii) sum of those integers from 1 to 500 which are multiples of 2 as well as of 5 .
- (iii) sum of those integers from 1 to 500 which are multiples of 2 or 5.

[**Hint (iii)** : These numbers will be : multiples of 2 + multiples of 5 – multiples of 2 as well as of 5]

- 3.** The eighth term of an AP is half its second term and the eleventh term exceeds one third of its fourth term by 1. Find the 15th term.
- 4.** An AP consists of 37 terms. The sum of the three middle most terms is 225 and the sum of the last three is 429. Find the AP.

5. Find the sum of the integers between 100 and 200 that are

- (i) divisible by 9
- (ii) not divisible by 9

[**Hint (ii)** : These numbers will be : Total numbers – Total numbers divisible by 9]

- 6.** The ratio of the 11th term to the 18th term of an AP is 2 : 3. Find the ratio of the 5th term to the 21st term, and also the ratio of the sum of the first five terms to the sum of the first 21 terms.
- 7.** Show that the sum of an AP whose first term is a , the second term b and the last term c , is equal to

$$\frac{a + c}{2} = \frac{b + c - 2a}{b - a}$$

8. Solve the equation

$$-4 + (-1) + 2 + \dots + x = 437$$

- 9.** Jaspal Singh repays his total loan of Rs 118000 by paying every month starting with the first instalment of Rs 1000. If he increases the instalment by Rs 100 every month, what amount will be paid by him in the 30th instalment? What amount of loan does he still have to pay after the 30th instalment?

- 10.** The students of a school decided to beautify the school on the Annual Day by fixing colourful flags on the straight passage of the school. They have 27 flags to be fixed at intervals of every 2 m. The flags are stored at the position of the middle most flag. Ruchi was given the responsibility of placing the flags. Ruchi kept her books where the flags were stored. She could carry only one flag at a time. How much distance did she cover in completing this job and returning back to collect her books? What is the maximum distance she travelled carrying a flag?

COORDINATE GEOMETRY

(A) Main Concepts and Results

Distance Formula, Section Formula, Area of a Triangle.

- The distance between two points P (x_1, y_1) and Q (x_2, y_2) is

$$\sqrt{(x_2 - x_1)^2 + (y_2 - y_1)^2}$$

- The distance of a point P (x, y) from the origin is $\sqrt{x^2 + y^2}$
- The coordinates of the point P which divides the line segment joining the points A (x_1, y_1) and B (x_2, y_2) internally in the ratio $m_1 : m_2$ are

$$\left(\frac{m_1 x_2 + m_2 x_1}{m_1 + m_2}, \frac{m_1 y_2 + m_2 y_1}{m_1 + m_2} \right)$$

- The coordinates of the mid-point of the line segment joining the points P (x_1, y_1)

and Q (x_2, y_2) are $\left(\frac{x_1 + x_2}{2}, \frac{y_1 + y_2}{2} \right)$

- The area of a triangle with vertices A (x_1, y_1) , B (x_2, y_2) and C (x_3, y_3) is

$$\frac{1}{2} [x_1 (y_2 - y_3) + x_2 (y_3 - y_1) + x_3 (y_1 - y_2)]$$

which is non-zero unless the points A, B and C are collinear.

(B) Multiple Choice Questions

Choose the correct answer from the given four options:

Sample Question 1: If the distance between the points $(2, -2)$ and $(-1, x)$ is 5, one of the values of x is

- (A) -2 (B) 2 (C) -1 (D) 1

Solution : Answer (B)

Sample Question 2: The mid-point of the line segment joining the points A $(-2, 8)$ and B $(-6, -4)$ is

- (A) $(-4, -6)$ (B) $(2, 6)$ (C) $(-4, 2)$ (D) $(4, 2)$

Solution : Answer (C)

Sample Question 3: The points A $(9, 0)$, B $(9, 6)$, C $(-9, 6)$ and D $(-9, 0)$ are the vertices of a

- (A) square (B) rectangle (C) rhombus (D) trapezium

Solution : Answer (B)

EXERCISE 7.1

Choose the correct answer from the given four options:

- The distance of the point P $(2, 3)$ from the x -axis is
(A) 2 (B) 3 (C) 1 (D) 5
- The distance between the points A $(0, 6)$ and B $(0, -2)$ is
(A) 6 (B) 8 (C) 4 (D) 2
- The distance of the point P $(-6, 8)$ from the origin is
(A) 8 (B) $2\sqrt{7}$ (C) 10 (D) 6
- The distance between the points $(0, 5)$ and $(-5, 0)$ is
(A) 5 (B) $5\sqrt{2}$ (C) $2\sqrt{5}$ (D) 10
- AOBC is a rectangle whose three vertices are vertices A $(0, 3)$, O $(0, 0)$ and B $(5, 0)$. The length of its diagonal is
(A) 5 (B) 3 (C) $\sqrt{34}$ (D) 4
- The perimeter of a triangle with vertices $(0, 4)$, $(0, 0)$ and $(3, 0)$ is
(A) 5 (B) 12 (C) 11 (D) $7+\sqrt{5}$
- The area of a triangle with vertices A $(3, 0)$, B $(7, 0)$ and C $(8, 4)$ is
(A) 14 (B) 28 (C) 8 (D) 6
- The points $(-4, 0)$, $(4, 0)$, $(0, 3)$ are the vertices of a
(A) right triangle (B) isosceles triangle
(C) equilateral triangle (D) scalene triangle

9. The point which divides the line segment joining the points (7, -6) and (3, 4) in ratio 1 : 2 internally lies in the
 (A) I quadrant (B) II quadrant
 (C) III quadrant (D) IV quadrant
10. The point which lies on the perpendicular bisector of the line segment joining the points A(-2, -5) and B (2, 5) is
 (A) (0, 0) (B) (0, 2) (C) (2, 0) (D) (-2, 0)
11. The fourth vertex D of a parallelogram ABCD whose three vertices are A(-2, 3), B (6, 7) and C (8, 3) is
 (A) (0, 1) (B) (0, -1) (C) (-1, 0) (D) (1, 0)
12. If the point P (2, 1) lies on the line segment joining points A (4, 2) and B (8, 4), then
 (A) $AP = \frac{1}{3} AB$ (B) $AP = PB$ (C) $PB = \frac{1}{3} AB$ (D) $AP = \frac{1}{2} AB$

13. If P $\frac{a}{3}, 4$ is the mid-point of the line segment joining the points Q (-6, 5) and R (-2, 3), then the value of a is
 (A) -4 (B) -12 (C) 12 (D) -6

14. The perpendicular bisector of the line segment joining the points A (1, 5) and B (4, 6) cuts the y-axis at
 (A) (0, 13) (B) (0, -13)
 (C) (0, 12) (D) (13, 0)

15. The coordinates of the point which is equidistant from the three vertices of the ΔAOB as shown in the Fig. 7.1 is
 (A) (x, y) (B) (y, x)
 (C) $\frac{x}{2}, \frac{y}{2}$ (D) $\frac{y}{2}, \frac{x}{2}$

16. A circle drawn with origin as the centre passes through $(\frac{13}{2}, 0)$. The point which does not lie in the interior of the circle is

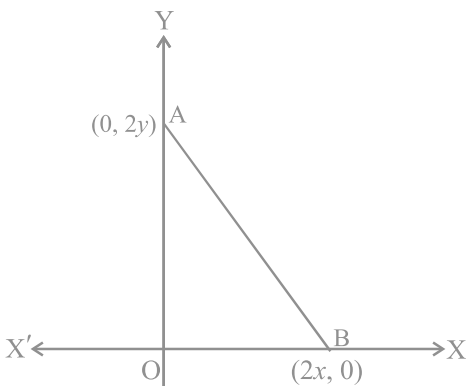

Fig. 7.1

(A) $\frac{-3}{4}, 1$ (B) $2, \frac{7}{3}$ (C) $5, \frac{-1}{2}$ (D) $\left(-6, \frac{5}{2}\right)$

17. A line intersects the y -axis and x -axis at the points P and Q, respectively. If $(2, -5)$ is the mid-point of PQ, then the coordinates of P and Q are, respectively
 (A) $(0, -5)$ and $(2, 0)$ (B) $(0, 10)$ and $(-4, 0)$
 (C) $(0, 4)$ and $(-10, 0)$ (D) $(0, -10)$ and $(4, 0)$
18. The area of a triangle with vertices $(a, b + c)$, $(b, c + a)$ and $(c, a + b)$ is
 (A) $(a + b + c)^2$ (B) 0 (C) $a + b + c$ (D) abc
19. If the distance between the points $(4, p)$ and $(1, 0)$ is 5, then the value of p is
 (A) 4 only (B) ± 4 (C) -4 only (D) 0
20. If the points A $(1, 2)$, O $(0, 0)$ and C (a, b) are collinear, then
 (A) $a = b$ (B) $a = 2b$ (C) $2a = b$ (D) $a = -b$

(C) Short Answer Questions with Reasoning

State whether the following statements are true or false. Justify your answer.

Sample Question 1 : The points A $(-1, 0)$, B $(3, 1)$, C $(2, 2)$ and D $(-2, 1)$ are the vertices of a parallelogram.

Solution : True. The coordinates of the mid-points of both the diagonals AC and BD are $\frac{1}{2}, 1$, i.e., the diagonals bisect each other.

Sample Question 2 : The points $(4, 5)$, $(7, 6)$ and $(6, 3)$ are collinear.

Solution : False. Since the area of the triangle formed by the points is 4 sq. units, the points are not collinear.

Sample Question 3 : Point P $(0, -7)$ is the point of intersection of y -axis and perpendicular bisector of line segment joining the points A $(-1, 0)$ and B $(7, -6)$.

Solution : True. P $(0, -7)$ lies on the y -axis. It is at a distance of $\sqrt{50}$ units from both the points $(-1, 0)$ and $(7, -6)$.

EXERCISE 7.2

State whether the following statements are true or false. Justify your answer.

1. ΔABC with vertices A $(-2, 0)$, B $(2, 0)$ and C $(0, 2)$ is similar to ΔDEF with vertices D $(-4, 0)$, E $(4, 0)$ and F $(0, 4)$.

2. Point P(-4, 2) lies on the line segment joining the points A(-4, 6) and B(-4, -6).
3. The points (0, 5), (0, -9) and (3, 6) are collinear.
4. Point P(0, 2) is the point of intersection of y-axis and perpendicular bisector of line segment joining the points A(-1, 1) and B(3, 3).
5. Points A(3, 1), B(12, -2) and C(0, 2) cannot be the vertices of a triangle.
6. Points A(4, 3), B(6, 4), C(5, -6) and D(-3, 5) are the vertices of a parallelogram.
7. A circle has its centre at the origin and a point P(5, 0) lies on it. The point Q(6, 8) lies outside the circle.
8. The point A(2, 7) lies on the perpendicular bisector of line segment joining the points P(6, 5) and Q(0, -4).
9. Point P(5, -3) is one of the two points of trisection of the line segment joining the points A(7, -2) and B(1, -5).
10. Points A(-6, 10), B(-4, 6) and C(3, -8) are collinear such that $AB = \frac{2}{9}AC$.
11. The point P(-2, 4) lies on a circle of radius 6 and centre C(3, 5).
12. The points A(-1, -2), B(4, 3), C(2, 5) and D(-3, 0) in that order form a rectangle.

(D) Short Answer Questions

Sample Question 1 : If the mid-point of the line segment joining the points A(3, 4) and B(k, 6) is P(x, y) and $x + y - 10 = 0$, find the value of k.

Solution : Mid-point of the line segment joining A(3, 4) and B(k, 6) = $\frac{3+k}{2}, \frac{4+6}{2}$

$$= \frac{3+k}{2}, 5$$

Then, $\frac{3+k}{2}, 5 = (x, y)$

Therefore, $\frac{3+k}{2} = x$ and $5 = y$.

Since $x + y - 10 = 0$, we have

$$\frac{3+k}{2} + 5 - 10 = 0$$

i.e., $3 + k = 10$

Therefore, $k = 7$.

Sample Question 2 : Find the area of the triangle ABC with A (1, -4) and the mid-points of sides through A being (2, -1) and (0, -1).

Solution: Let the coordinates of B and C be (a, b) and (x, y), respectively.

$$\text{Then, } \left(\frac{1+a}{2}, \frac{-4+b}{2} \right) = (2, -1)$$

$$\text{Therefore, } \begin{aligned} 1+a &= 4, & -4+b &= -2 \\ a &= 3 & b &= 2 \end{aligned}$$

$$\text{Also, } \left(\frac{1+x}{2}, \frac{-4+y}{2} \right) = (0, -1)$$

$$\text{Therefore, } \begin{aligned} 1+x &= 0, & -4+y &= -2 \\ \text{i.e., } x &= -1 & \text{i.e., } y &= 2 \end{aligned}$$

The coordinates of the vertices of ΔABC are A (1, -4), B (3, 2) and C (-1, 2).

$$\begin{aligned} \text{Area of } \Delta ABC &= \frac{1}{2} [1(2-2) + 3(2+4) - 1(-4-2)] \\ &= \frac{1}{2} [18+6] \\ &= 12 \text{ sq. units.} \end{aligned}$$

Sample Question 3 : Name the type of triangle PQR formed by the points P $(\sqrt{2}, \sqrt{2})$,
Q $(-\sqrt{2}, -\sqrt{2})$ and R $(-\sqrt{6}, \sqrt{6})$.

Solution : Using distance formula

$$PQ = \sqrt{(\sqrt{2} + \sqrt{2})^2 + (\sqrt{2} + \sqrt{2})^2} = \sqrt{(2\sqrt{2})^2 + (2\sqrt{2})^2} = \sqrt{16} = 4$$

$$PR = \sqrt{(\sqrt{2} + \sqrt{6})^2 + (\sqrt{2} - \sqrt{6})^2} = \sqrt{2 + 6 + 2\sqrt{12} + 2 + 6 - 2\sqrt{12}} = \sqrt{16} = 4$$

$$RQ = \sqrt{(-\sqrt{2} + \sqrt{6})^2 + (-\sqrt{2} - \sqrt{6})^2} = \sqrt{2 + 6 - 2\sqrt{12} + 2 + 6 + 2\sqrt{12}} = \sqrt{16} = 4$$

Since $PQ = PR = RQ = 4$, points P, Q, R form an equilateral triangle.

Sample Question 4 : ABCD is a parallelogram with vertices A (x_1, y_1) , B (x_2, y_2) and C (x_3, y_3) . Find the coordinates of the fourth vertex D in terms of x_1, x_2, x_3, y_1, y_2 and y_3 .

Solution: Let the coordinates of D be (x, y) . We know that diagonals of a parallelogram bisect each other.

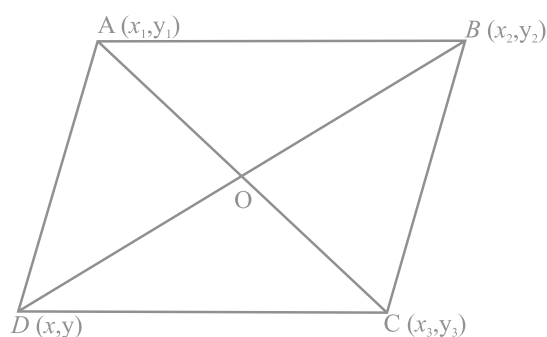

Fig. 7.2

Therefore, mid-point of AC = mid-point of BD $\frac{x_1 + x_3}{2}, \frac{y_1 + y_3}{2} = \frac{x_2 + x}{2}, \frac{y_2 + y}{2}$

i.e., $x_1 + x_3 = x_2 + x$ and $y_1 + y_3 = y_2 + y$

i.e., $x_1 + x_3 - x_2 = x$ and $y_1 + y_3 - y_2 = y$

Thus, the coordinates of D are

$(x_1 + x_3 - x_2, y_1 + y_3 - y_2)$

EXERCISE 7.3

1. Name the type of triangle formed by the points A $(-5, 6)$, B $(-4, -2)$ and C $(7, 5)$.
2. Find the points on the x -axis which are at a distance of $2\sqrt{5}$ from the point $(7, -4)$. How many such points are there?
3. What type of a quadrilateral do the points A $(2, -2)$, B $(7, 3)$, C $(11, -1)$ and D $(6, -6)$ taken in that order, form?
4. Find the value of a , if the distance between the points A $(-3, -14)$ and B $(a, -5)$ is 9 units.
5. Find a point which is equidistant from the points A $(-5, 4)$ and B $(-1, 6)$? How many such points are there?

6. Find the coordinates of the point Q on the x -axis which lies on the perpendicular bisector of the line segment joining the points A $(-5, -2)$ and B $(4, -2)$. Name the type of triangle formed by the points Q, A and B.
7. Find the value of m if the points $(5, 1)$, $(-2, -3)$ and $(8, 2m)$ are collinear.
8. If the point A $(2, -4)$ is equidistant from P $(3, 8)$ and Q $(-10, y)$, find the values of y . Also find distance PQ.
9. Find the area of the triangle whose vertices are $(-8, 4)$, $(-6, 6)$ and $(-3, 9)$.
10. In what ratio does the x -axis divide the line segment joining the points $(-4, -6)$ and $(-1, 7)$? Find the coordinates of the point of division.
11. Find the ratio in which the point P $\left(\frac{3}{4}, \frac{5}{12}\right)$ divides the line segment joining the points A $\left(\frac{1}{2}, \frac{3}{2}\right)$ and B $(2, -5)$.
12. If P $(9a - 2, -b)$ divides line segment joining A $(3a + 1, -3)$ and B $(8a, 5)$ in the ratio $3 : 1$, find the values of a and b .
13. If (a, b) is the mid-point of the line segment joining the points A $(10, -6)$ and B $(k, 4)$ and $a - 2b = 18$, find the value of k and the distance AB.
14. The centre of a circle is $(2a, a - 7)$. Find the values of a if the circle passes through the point $(11, -9)$ and has diameter $10\sqrt{2}$ units.
15. The line segment joining the points A $(3, 2)$ and B $(5, 1)$ is divided at the point P in the ratio $1:2$ and it lies on the line $3x - 18y + k = 0$. Find the value of k .
16. If D $\left(\frac{-1}{2}, \frac{5}{2}\right)$, E $(7, 3)$ and F $\left(\frac{7}{2}, \frac{7}{2}\right)$ are the midpoints of sides of ΔABC , find the area of the ΔABC .
17. The points A $(2, 9)$, B $(a, 5)$ and C $(5, 5)$ are the vertices of a triangle ABC right angled at B. Find the values of a and hence the area of ΔABC .
18. Find the coordinates of the point R on the line segment joining the points P $(-1, 3)$ and Q $(2, 5)$ such that $PR = \frac{3}{5}PQ$.
19. Find the values of k if the points A $(k + 1, 2k)$, B $(3k, 2k + 3)$ and C $(5k - 1, 5k)$ are collinear.
20. Find the ratio in which the line $2x + 3y - 5 = 0$ divides the line segment joining the points $(8, -9)$ and $(2, 1)$. Also find the coordinates of the point of division.

(E) Long Answer Questions

Sample Question 1 : The mid-points D, E, F of the sides of a triangle ABC are (3, 4), (8, 9) and (6, 7). Find the coordinates of the vertices of the triangle.

Solution : Since D and F are the mid-points of AB and AC, respectively, by mid-point theorem, we can prove that DFEB is a parallelogram. Let the coordinates of B be (x, y).

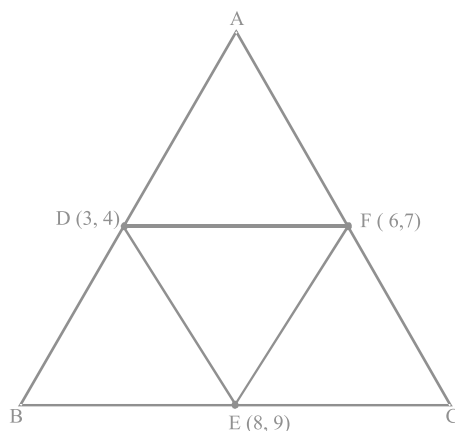

Fig. 7.3

Refer to Sample Question 4 of Section (D) to get

$$x = 3 + 8 - 6 = 5$$

$$y = 4 + 9 - 7 = 6$$

Therefore, B (5, 6) is one of the vertices of the triangle.

Similarly DFCE and DAFE are also parallelograms, and the coordinates of A are $(3 + 6 - 8, 4 + 7 - 9) = (1, 2)$. Coordinates of C are $(8 + 6 - 3, 9 + 7 - 4) = (11, 12)$. Thus, the coordinates of the vertices of the triangle are A(1, 2), B(5,6) and C (11, 12).

EXERCISE 7.4

1. If $(-4, 3)$ and $(4, 3)$ are two vertices of an equilateral triangle, find the coordinates of the third vertex, given that the origin lies in the interior of the triangle.
2. A $(6, 1)$, B $(8, 2)$ and C $(9, 4)$ are three vertices of a parallelogram ABCD. If E is the midpoint of DC, find the area of $\triangle ADE$.

3. The points $A(x_1, y_1)$, $B(x_2, y_2)$ and $C(x_3, y_3)$ are the vertices of ΔABC .
- The median from A meets BC at D . Find the coordinates of the point D .
 - Find the coordinates of the point P on AD such that $AP : PD = 2 : 1$
 - Find the coordinates of points Q and R on medians BE and CF , respectively such that $BQ : QE = 2 : 1$ and $CR : RF = 2 : 1$
 - What are the coordinates of the centroid of the triangle ABC ?
4. If the points $A(1, -2)$, $B(2, 3)$, $C(a, 2)$ and $D(-4, -3)$ form a parallelogram, find the value of a and height of the parallelogram taking AB as base.
5. Students of a school are standing in rows and columns in their playground for a drill practice. A , B , C and D are the positions of four students as shown in figure 7.4. Is it possible to place Jaspal in the drill in such a way that he is equidistant from each of the four students A , B , C and D ? If so, what should be his position?

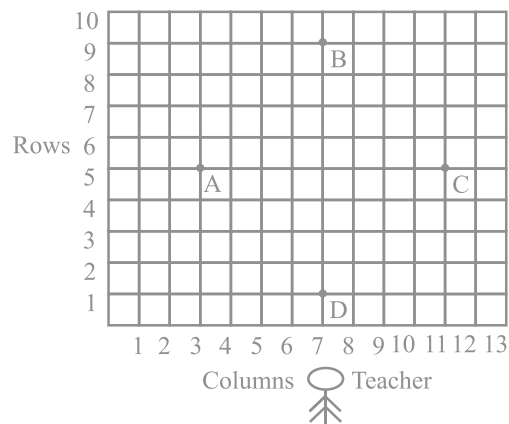

Fig. 7.4

6. Ayush starts walking from his house to office. Instead of going to the office directly, he goes to a bank first, from there to his daughter's school and then reaches the office. What is the extra distance travelled by Ayush in reaching his office? (Assume that all distances covered are in straight lines).
If the house is situated at $(2, 4)$, bank at $(5, 8)$, school at $(13, 14)$ and office at $(13, 26)$ and coordinates are in km.

INTRODUCTION TO TRIGONOMETRY AND ITS APPLICATIONS

(A) Main Concepts and Results

- Trigonometric Ratios of the angle A in a triangle ABC right angled at B are defined as:

$$\text{sine of } \angle A = \sin A = \frac{\text{side opposite to } \angle A}{\text{hypotenuse}} = \frac{BC}{AC}$$

$$\text{cosine of } \angle A = \cos A = \frac{\text{side adjacent to } \angle A}{\text{hypotenuse}} = \frac{AB}{AC}$$

$$\text{tangent of } \angle A = \tan A = \frac{\text{side opposite to } \angle A}{\text{side adjacent to angle } \angle A} = \frac{BC}{AB}$$

$$\text{cosecant of } \angle A = \operatorname{cosec} A = \frac{1}{\sin A} = \frac{AC}{BC}$$

$$\text{secant of } \angle A = \sec A = \frac{1}{\cos A} = \frac{AC}{AB}$$

$$\text{cotangent of } \angle A = \cot A = \frac{1}{\tan A} = \frac{AB}{BC}$$

$$\tan A = \frac{\sin A}{\cos A}, \cot A = \frac{\cos A}{\sin A}$$

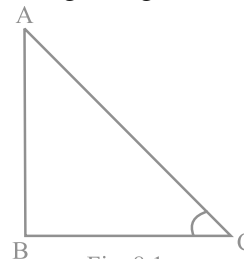

Fig. 8.1

- The values of trigonometric ratios of an angle do not vary with the lengths of the sides of the triangle, if the angle remains the same.
- If one trigonometric ratio of an angle is given, the other trigonometric ratios of the angle can be determined.
- Trigonometric ratios of angles: 0° , 30° , 45° , 60° and 90° .

A	0°	30°	45°	60°	90°
sin A	0	$\frac{1}{2}$	$\frac{1}{\sqrt{2}}$	$\frac{\sqrt{3}}{2}$	1
cos A	1	$\frac{\sqrt{3}}{2}$	$\frac{1}{\sqrt{2}}$	$\frac{1}{2}$	0
tan A	0	$\frac{1}{\sqrt{3}}$	1	$\sqrt{3}$	Not defined
cosec A	Not defined	2	$\sqrt{2}$	$\frac{2}{\sqrt{3}}$	1
sec A	1	$\frac{2}{\sqrt{3}}$	$\sqrt{2}$	2	Not defined
cot A	Not defined	$\sqrt{3}$	1	$\frac{1}{\sqrt{3}}$	0

- The value of sin A or cos A never exceeds 1, whereas the value of sec A or cosec A is always greater than or equal to 1.
- Trigonometric ratios of complementary angles:
 $\sin(90^\circ - A) = \cos A$, $\cos(90^\circ - A) = \sin A$
 $\tan(90^\circ - A) = \cot A$, $\cot(90^\circ - A) = \tan A$
 $\sec(90^\circ - A) = \text{cosec } A$, $\text{cosec}(90^\circ - A) = \sec A$
- Trigonometric identities:
 $\cos^2 A + \sin^2 A = 1$
 $1 + \tan^2 A = \sec^2 A$
 $\cot^2 A + 1 = \text{cosec}^2 A$

- The 'line of sight' is the line from the eye of an observer to the point in the object viewed by the observer.
- The 'angle of elevation' of an object viewed, is the angle formed by the line of sight with the horizontal when it is above the horizontal level.
- The angle of depression of an object viewed, is the angle formed by the line of sight with the horizontal when it is below the horizontal level.
- The height or length of an object or the distance between two distinct objects can be determined with the help of trigonometric ratios.

(B) Multiple Choice Questions

Choose the correct answer from the given four options:

Sample Question 1 : The value of $(\sin 30^\circ + \cos 30^\circ) - (\sin 60^\circ + \cos 60^\circ)$ is

- (A) -1 (B) 0 (C) 1 (D) 2

Solution : Answer (B)

Sample Question 2 : The value of $\frac{\tan 30}{\cot 60}$ is

- (A) $\frac{1}{\sqrt{2}}$ (B) $\frac{1}{\sqrt{3}}$ (C) $\sqrt{3}$ (D) 1

Solution : Answer (D)

Sample Question 3 : The value of $(\sin 45^\circ + \cos 45^\circ)$ is

- (A) $\frac{1}{\sqrt{2}}$ (B) $\sqrt{2}$ (C) $\frac{\sqrt{3}}{2}$ (D) 1

Solution : Answer (B)

EXERCISE 8.1

Choose the correct answer from the given four options:

1. If $\cos A = \frac{4}{5}$, then the value of $\tan A$ is

- (A) $\frac{3}{5}$ (B) $\frac{3}{4}$ (C) $\frac{4}{3}$ (D) $\frac{5}{3}$

2. If $\sin A = \frac{1}{2}$, then the value of $\cot A$ is
- (A) $\sqrt{3}$ (B) $\frac{1}{\sqrt{3}}$ (C) $\frac{\sqrt{3}}{2}$ (D) 1
3. The value of the expression $[\operatorname{cosec}(75^\circ + \theta) - \sec(15^\circ - \theta) - \tan(55^\circ + \theta) + \cot(35^\circ - \theta)]$ is
- (A) -1 (B) 0 (C) 1 (D) $\frac{3}{2}$
4. Given that $\sin\theta = \frac{a}{b}$, then $\cos\theta$ is equal to
- (A) $\frac{b}{\sqrt{b^2 - a^2}}$ (B) $\frac{b}{a}$ (C) $\frac{\sqrt{b^2 - a^2}}{b}$ (D) $\frac{a}{\sqrt{b^2 - a^2}}$
5. If $\cos(\alpha + \beta) = 0$, then $\sin(\alpha - \beta)$ can be reduced to
- (A) $\cos\beta$ (B) $\cos 2\beta$ (C) $\sin\alpha$ (D) $\sin 2\alpha$
6. The value of $(\tan 1^\circ \tan 2^\circ \tan 3^\circ \dots \tan 89^\circ)$ is
- (A) 0 (B) 1 (C) 2 (D) $\frac{1}{2}$
7. If $\cos 9\alpha = \sin\alpha$ and $9\alpha < 90^\circ$, then the value of $\tan 5\alpha$ is
- (A) $\frac{1}{\sqrt{3}}$ (B) $\sqrt{3}$ (C) 1 (D) 0
8. If $\triangle ABC$ is right angled at C, then the value of $\cos(A+B)$ is
- (A) 0 (B) 1 (C) $\frac{1}{2}$ (D) $\frac{\sqrt{3}}{2}$
9. If $\sin A + \sin^2 A = 1$, then the value of the expression $(\cos^2 A + \cos^4 A)$ is
- (A) 1 (B) $\frac{1}{2}$ (C) 2 (D) 3
10. Given that $\sin\alpha = \frac{1}{2}$ and $\cos\beta = \frac{1}{2}$, then the value of $(\alpha + \beta)$ is
- (A) 0° (B) 30° (C) 60° (D) 90°

11. The value of the expression $\left[\frac{\sin^2 22^\circ + \sin^2 68^\circ}{\cos^2 22^\circ + \cos^2 68^\circ} + \sin^2 63^\circ + \cos 63^\circ \sin 27^\circ \right]$ is

- (A) 3 (B) 2 (C) 1 (D) 0

12. If $4 \tan \theta = 3$, then $\left(\frac{4 \sin \theta - \cos \theta}{4 \sin \theta + \cos \theta} \right)$ is equal to

- (A) $\frac{2}{3}$ (B) $\frac{1}{3}$ (C) $\frac{1}{2}$ (D) $\frac{3}{4}$

13. If $\sin \theta - \cos \theta = 0$, then the value of $(\sin^4 \theta + \cos^4 \theta)$ is

- (A) 1 (B) $\frac{3}{4}$ (C) $\frac{1}{2}$ (D) $\frac{1}{4}$

14. $\sin(45^\circ + \theta) - \cos(45^\circ - \theta)$ is equal to

- (A) $2 \cos \theta$ (B) 0 (C) $2 \sin \theta$ (D) 1

15. A pole 6 m high casts a shadow $2\sqrt{3}$ m long on the ground, then the Sun's elevation is

- (A) 60° (B) 45° (C) 30° (D) 90°

(C) Short Answer Questions with Reasoning

Write 'True' or 'False' and justify your answer.

Sample Question 1 : The value of $\sin \theta + \cos \theta$ is always greater than 1.

Solution : False.

The value of $(\sin \theta + \cos \theta)$ for $\theta = 0^\circ$ is 1.

Sample Question 2 : The value of $\tan \theta$ ($\theta < 90^\circ$) increases as θ increases.

Solution : True.

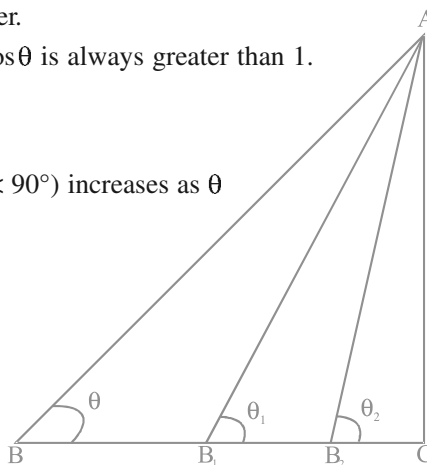

Fig. 8.2

In Fig. 8.2, B is moved closer to C along BC. It is observed that

- (i) θ increases (as $\theta_1 > \theta$, $\theta_2 > \theta_1$, ...) and
- (ii) BC decreases ($B_1C < BC$, $B_2C < B_1C$, ...)

Thus the perpendicular AC remains fixed and the base BC decreases. Hence $\tan\theta$ increases as θ increases.

Sample Question 3 : $\tan\theta$ increases faster than $\sin\theta$ as θ increases.

Solution : True

We know that $\sin\theta$ increases as θ increases but $\cos\theta$ decreases as θ increases.

We have $\tan\theta = \frac{\sin\theta}{\cos\theta}$

Now as θ increases, $\sin\theta$ increases but $\cos\theta$ decreases. Therefore, in case of $\tan\theta$, the numerator increases and the denominator decreases. But in case of $\sin\theta$ which can be

seen as $\frac{\sin\theta}{1}$, only the numerator increases but the denominator remains fixed at 1.

Hence $\tan\theta$ increases faster than $\sin\theta$ as θ increases.

Sample Question 4 : The value of $\sin\theta$ is $a \frac{1}{a}$, where 'a' is a positive number.

Solution : False.

We know that $\sqrt{a} \frac{1}{\sqrt{a}} = 1$ or $a \frac{1}{a} = 1$, but $\sin\theta$ is not greater than 1.

Alternatively, there exists the following three possibilities :

Case 1. If $a < 1$, then $a \frac{1}{a} > 1$

Case 2. If $a = 1$, then $a \frac{1}{a} = 1$

Case 3. If $a > 1$, then $a \frac{1}{a} < 1$

However, $\sin\theta$ cannot be greater than 1.

EXERCISE 8.2

Write 'True' or 'False' and justify your answer in each of the following:

1. $\frac{\tan 47^\circ}{\cot 43^\circ} = 1$
2. The value of the expression $(\cos^2 23^\circ - \sin^2 67^\circ)$ is positive.
3. The value of the expression $(\sin 80^\circ - \cos 80^\circ)$ is negative.
4. $\sqrt{(1 - \cos^2 \theta) \sec^2 \theta} = \tan \theta$
5. If $\cos A + \cos^2 A = 1$, then $\sin^2 A + \sin^4 A = 1$.
6. $(\tan \theta + 2)(2 \tan \theta + 1) = 5 \tan \theta + \sec^2 \theta$.
7. If the length of the shadow of a tower is increasing, then the angle of elevation of the sun is also increasing.
8. If a man standing on a platform 3 metres above the surface of a lake observes a cloud and its reflection in the lake, then the angle of elevation of the cloud is equal to the angle of depression of its reflection.
9. The value of $2\sin\theta$ can be $a \frac{1}{a}$, where a is a positive number, and $a \neq 1$.
10. $\cos \theta = \frac{a^2 - b^2}{2ab}$, where a and b are two distinct numbers such that $ab > 0$.
11. The angle of elevation of the top of a tower is 30° . If the height of the tower is doubled, then the angle of elevation of its top will also be doubled.
12. If the height of a tower and the distance of the point of observation from its foot, both, are increased by 10%, then the angle of elevation of its top remains unchanged.

(D) Short Answer Questions

Sample Question 1 : Prove that $\sin^6\theta + \cos^6\theta + 3\sin^2\theta \cos^2\theta = 1$

Solution : We know that $\sin^2\theta + \cos^2\theta = 1$

Therefore, $(\sin^2\theta + \cos^2\theta)^3 = 1$

or, $(\sin^2\theta)^3 + (\cos^2\theta)^3 + 3\sin^2\theta \cos^2\theta (\sin^2\theta + \cos^2\theta) = 1$

or, $\sin^6\theta + \cos^6\theta + 3\sin^2\theta \cos^2\theta = 1$

Sample Question 2 : Prove that $(\sin^4\theta - \cos^4\theta + 1) \operatorname{cosec}^2\theta = 2$

Solution :

$$\begin{aligned}
 \text{L.H.S.} &= (\sin^4\theta - \cos^4\theta + 1) \operatorname{cosec}^2\theta \\
 &= [(\sin^2\theta - \cos^2\theta)(\sin^2\theta + \cos^2\theta) + 1] \operatorname{cosec}^2\theta \\
 &= (\sin^2\theta - \cos^2\theta + 1) \operatorname{cosec}^2\theta \\
 &\qquad\qquad\qquad [\text{Because } \sin^2\theta + \cos^2\theta = 1] \\
 &= 2\sin^2\theta \operatorname{cosec}^2\theta \qquad [\text{Because } 1 - \cos^2\theta = \sin^2\theta] \\
 &= 2 = \text{RHS}
 \end{aligned}$$

Sample Question 3 : Given that $\alpha + \beta = 90^\circ$, show that

$$\sqrt{\cos \alpha \operatorname{cosec} \beta - \cos \alpha \sin \beta} = \sin \alpha$$

Solution :

$$\begin{aligned}
 \sqrt{\cos \alpha \operatorname{cosec} \beta - \cos \alpha \sin \beta} &= \sqrt{\cos \alpha \operatorname{cosec} (90^\circ - \alpha) - \cos \alpha \sin (90^\circ - \alpha)} \\
 &\qquad\qquad\qquad [\text{Given } \alpha + \beta = 90^\circ] \\
 &= \sqrt{\cos \alpha \sec \alpha - \cos \alpha \cos \alpha} \\
 &= \sqrt{1 - \cos^2 \alpha} \\
 &= \sin \alpha
 \end{aligned}$$

Sample Question 4 : If $\sin \theta + \cos \theta = \sqrt{3}$, then prove that $\tan \theta + \cot \theta = 1$

Solution :

$$\sin \theta + \cos \theta = \sqrt{3} \qquad\qquad\qquad (\text{Given})$$

or $(\sin \theta + \cos \theta)^2 = 3$

or $\sin^2 \theta + \cos^2 \theta + 2\sin \theta \cos \theta = 3$

$$2\sin \theta \cos \theta = 2 \qquad\qquad\qquad [\sin^2 \theta + \cos^2 \theta = 1]$$

or $\sin \theta \cos \theta = 1 = \sin^2 \theta + \cos^2 \theta$

or $1 \frac{\sin^2 \theta + \cos^2 \theta}{\sin \theta \cos \theta}$

Therefore, $\tan \theta + \cot \theta = 1$

EXERCISE 8.3

Prove the following (from Q.1 to Q.7):

1. $\frac{\sin \theta}{1 + \cos \theta} + \frac{1 + \cos \theta}{\sin \theta} = 2 \operatorname{cosec} \theta$
2. $\frac{\tan A}{1 - \sec A} - \frac{\tan A}{1 + \sec A} = 2 \operatorname{cosec} A$
3. If $\tan A = \frac{3}{4}$, then $\sin A \cos A = \frac{12}{25}$
4. $(\sin \alpha + \cos \alpha)(\tan \alpha + \cot \alpha) = \sec \alpha + \operatorname{cosec} \alpha$
5. $\sqrt{3} - 1 - (3 - \cot 30^\circ) = \tan^3 60^\circ - 2 \sin 60^\circ$
6. $1 + \frac{\cot^2 \alpha}{1 + \operatorname{cosec} \alpha} = \operatorname{cosec} \alpha$
7. $\tan \theta + \tan (90^\circ - \theta) = \sec \theta \sec (90^\circ - \theta)$
8. Find the angle of elevation of the sun when the shadow of a pole h metres high is $\sqrt{3} h$ metres long.
9. If $\sqrt{3} \tan \theta = 1$, then find the value of $\sin^2 \theta - \cos^2 \theta$.
10. A ladder 15 metres long just reaches the top of a vertical wall. If the ladder makes an angle of 60° with the wall, find the height of the wall.
11. Simplify $(1 + \tan^2 \theta)(1 - \sin \theta)(1 + \sin \theta)$
12. If $2 \sin^2 \theta - \cos^2 \theta = 2$, then find the value of θ .
13. Show that $\frac{\cos^2 (45^\circ + \theta) + \cos^2 (45^\circ - \theta)}{\tan (60^\circ + \theta) \tan (30^\circ - \theta)} = 1$
14. An observer 1.5 metres tall is 20.5 metres away from a tower 22 metres high. Determine the angle of elevation of the top of the tower from the eye of the observer.
15. Show that $\tan^4 \theta + \tan^2 \theta = \sec^4 \theta - \sec^2 \theta$.

(E) Long Answer Questions

Sample Question 1 : A spherical balloon of radius r subtends an angle θ at the eye of an observer. If the angle of elevation of its centre is ϕ , find the height of the centre of the balloon.

Solution : In Fig. 8.3, O is the centre of balloon, whose radius $OP = r$ and $\angle PAQ = \theta$. Also, $\angle OAB = \phi$.

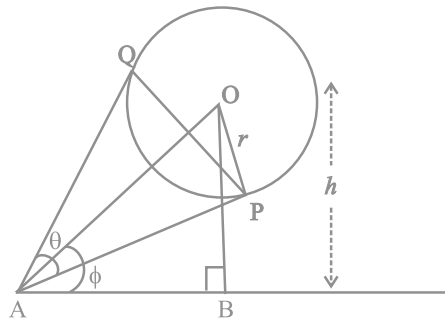

Fig. 8.3

Let the height of the centre of the balloon be h . Thus $OB = h$.

$$\text{Now, from } \triangle OAP, \sin \frac{\theta}{2} = \frac{r}{d}, \text{ where } OA = d \quad (1)$$

$$\text{Also from } \triangle OAB, \sin \phi = \frac{h}{d}. \quad (2)$$

$$\text{From (1) and (2), we get } \frac{\sin \phi}{\sin \frac{\theta}{2}} = \frac{\frac{h}{d}}{\frac{r}{d}} = \frac{h}{r}$$

$$\text{or } h = r \sin \phi \operatorname{cosec} \frac{\theta}{2}.$$

Sample Question 2 : From a balloon vertically above a straight road, the angles of depression of two cars at an instant are found to be 45° and 60° . If the cars are 100 m apart, find the height of the balloon.

Solution : Let the height of the balloon at P be h meters (see Fig. 8.4). Let A and B be the two cars. Thus $AB = 100$ m. From $\triangle PAQ$, $AQ = PQ = h$

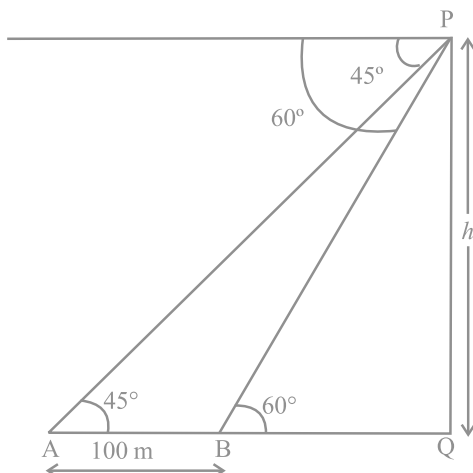

Fig. 8.4

$$\text{Now from } \triangle PBQ, \frac{PQ}{BQ} = \tan 60^\circ = \sqrt{3} \quad \text{or} \quad \frac{h}{h-100} = \sqrt{3}$$

$$\text{or} \quad h = \sqrt{3}(h-100)$$

$$\text{Therefore, } h = \frac{100\sqrt{3}}{\sqrt{3}-1} = 50(3+\sqrt{3})$$

i.e., the height of the balloon is $50(3+\sqrt{3})$ m.

Sample Question 3 : The angle of elevation of a cloud from a point h metres above the surface of a lake is θ and the angle of depression of its reflection in the lake is ϕ .

Prove that the height of the cloud above the lake is $h \left(\frac{\tan \phi + \tan \theta}{\tan \phi - \tan \theta} \right)$.

Solution : Let P be the cloud and Q be its reflection in the lake (see Fig. 8.5). Let A be the point of observation such that $AB = h$.

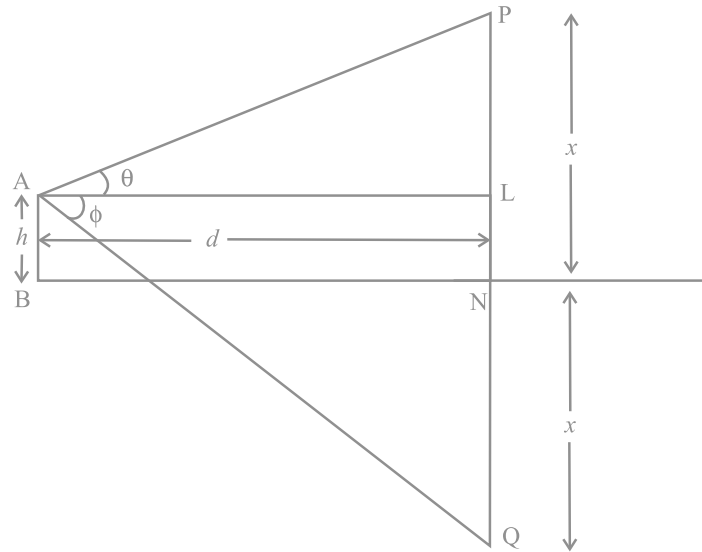

Fig. 8.5

Let the height of the cloud above the lake be x . Let $AL = d$.

$$\text{Now from } \triangle PAL, \frac{x-h}{d} = \tan \theta \quad (1)$$

$$\text{From } \triangle QAL, \frac{x+h}{d} = \tan \phi \quad (2)$$

From (1) and (2), we get

$$\frac{x+h}{x-h} = \frac{\tan \phi}{\tan \theta}$$

$$\text{or } \frac{2x}{2h} = \frac{\tan \phi + \tan \theta}{\tan \phi - \tan \theta}$$

$$\text{Therefore, } x = h \left(\frac{\tan \phi + \tan \theta}{\tan \phi - \tan \theta} \right).$$

EXERCISE 8.4

1. If $\operatorname{cosec}\theta + \cot\theta = p$, then prove that $\cos\theta = \frac{p^2 - 1}{p^2 + 1}$.
2. Prove that $\sqrt{\sec^2\theta + \operatorname{cosec}^2\theta} = \tan\theta + \cot\theta$.
3. The angle of elevation of the top of a tower from certain point is 30° . If the observer moves 20 metres towards the tower, the angle of elevation of the top increases by 15° . Find the height of the tower.
4. If $1 + \sin^2\theta = 3\sin\theta \cos\theta$, then prove that $\tan\theta = 1$ or $\frac{1}{2}$.
5. Given that $\sin\theta + 2\cos\theta = 1$, then prove that $2\sin\theta - \cos\theta = 2$.
6. The angle of elevation of the top of a tower from two points distant s and t from its foot are complementary. Prove that the height of the tower is \sqrt{st} .
7. The shadow of a tower standing on a level plane is found to be 50 m longer when Sun's elevation is 30° than when it is 60° . Find the height of the tower.
8. A vertical tower stands on a horizontal plane and is surmounted by a vertical flag staff of height h . At a point on the plane, the angles of elevation of the bottom and the top of the flag staff are α and β , respectively. Prove that the height of the tower is $\left(\frac{h \tan\alpha}{\tan\beta - \tan\alpha}\right)$.
9. If $\tan\theta + \sec\theta = l$, then prove that $\sec\theta = \frac{l^2 + 1}{2l}$.
10. If $\sin\theta + \cos\theta = p$ and $\sec\theta + \operatorname{cosec}\theta = q$, then prove that $q(p^2 - 1) = 2p$.
11. If $a \sin\theta + b \cos\theta = c$, then prove that $a \cos\theta - b \sin\theta = \sqrt{a^2 + b^2 - c^2}$.
12. Prove that $\frac{1 + \sec\theta - \tan\theta}{1 + \sec\theta + \tan\theta} = \frac{1 - \sin\theta}{\cos\theta}$.
13. The angle of elevation of the top of a tower 30 m high from the foot of another tower in the same plane is 60° and the angle of elevation of the top of the second tower from the foot of the first tower is 30° . Find the distance between the two towers and also the height of the other tower.

- 14.** From the top of a tower h m high, the angles of depression of two objects, which are in line with the foot of the tower are α and β ($\beta > \alpha$). Find the distance between the two objects.
- 15.** A ladder rests against a vertical wall at an inclination α to the horizontal. Its foot is pulled away from the wall through a distance p so that its upper end slides a distance q down the wall and then the ladder makes an angle β to the horizontal.

Show that
$$\frac{p}{q} = \frac{\cos \beta - \cos \alpha}{\sin \alpha - \sin \beta} .$$

- 16.** The angle of elevation of the top of a vertical tower from a point on the ground is 60° . From another point 10 m vertically above the first, its angle of elevation is 45° . Find the height of the tower.
- 17.** A window of a house is h metres above the ground. From the window, the angles of elevation and depression of the top and the bottom of another house situated on the opposite side of the lane are found to be α and β , respectively. Prove that the height of the other house is $h (1 + \tan \alpha \cot \beta)$ metres.
- 18.** The lower window of a house is at a height of 2 m above the ground and its upper window is 4 m vertically above the lower window. At certain instant the angles of elevation of a balloon from these windows are observed to be 60° and 30° , respectively. Find the height of the balloon above the ground.

CIRCLES

(A) Main Concepts and Results

- The meaning of a tangent and its point of contact on a circle.
- Tangent is perpendicular to the radius through the point of contact.
- Only two tangents can be drawn to a circle from an external point.
- Lengths of tangents from an external point to a circle are equal.

(B) Multiple Choice Questions

Choose the correct answer from the given four options:

Sample Question 1 : If angle between two radii of a circle is 130° , the angle between the tangents at the ends of the radii is :

- (A) 90° (B) 50° (C) 70° (D) 40°

Solution : Answer (B)

Sample Question 2 : In Fig. 9.1, the pair of tangents AP and AQ drawn from an external point A to a circle with centre O are perpendicular to each other and length of each tangent is 5 cm. Then the radius of the circle is

- (A) 10 cm (B) 7.5 cm
(C) 5 cm (D) 2.5 cm

Solution: Answer (C)

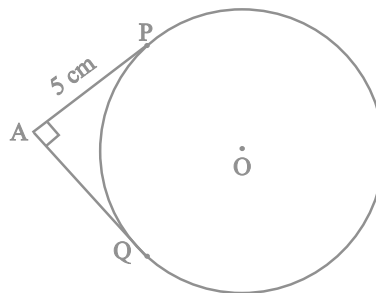

Fig. 9.1

Sample Question 3: In Fig. 9.2, PQ is a chord of a circle and PT is the tangent at P such that $\angle QPT = 60^\circ$. Then $\angle PRQ$ is equal to

- (A) 135° (B) 150°
 (C) 120° (D) 110°

Solution : Answer (C)

[Hint : $\angle OPQ = \angle OQP = 30^\circ$, i.e., $\angle POQ$

$= 120^\circ$. Also, $\angle PRQ = \frac{1}{2}$ reflex $\angle POQ$]

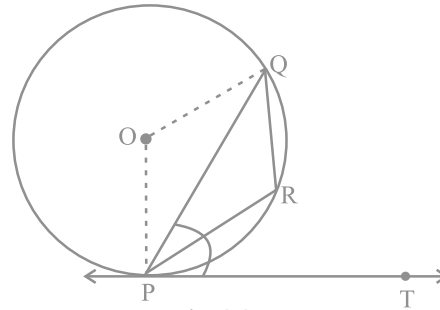

Fig. 9.2

EXERCISE 9.1

Choose the correct answer from the given four options:

1. If radii of two concentric circles are 4 cm and 5 cm, then the length of each chord of one circle which is tangent to the other circle is

- (A) 3 cm (B) 6 cm
 (C) 9 cm (D) 1 cm

2. In Fig. 9.3, if $\angle AOB = 125^\circ$, then $\angle COD$ is equal to

- (A) 62.5° (B) 45°
 (C) 35° (D) 55°

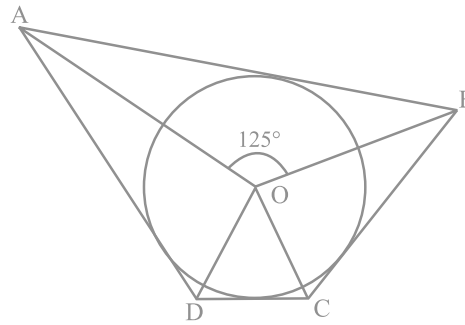

Fig. 9.3

3. In Fig. 9.4, AB is a chord of the circle and AOC is its diameter such that $\angle ACB = 50^\circ$. If AT is the tangent to the circle at the point A, then $\angle BAT$ is equal to

- (A) 65° (B) 60°
 (C) 50° (D) 40°

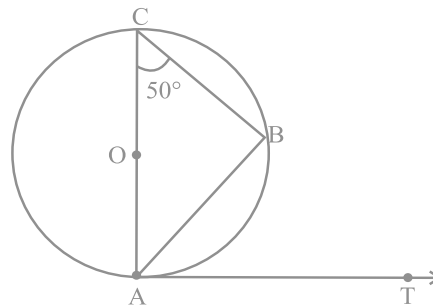

Fig. 9.4

4. From a point P which is at a distance of 13 cm from the centre O of a circle of radius 5 cm, the pair of tangents PQ and PR to the circle are drawn. Then the area of the quadrilateral PQOR is
 (A) 60 cm^2 (B) 65 cm^2 (C) 30 cm^2 (D) 32.5 cm^2
5. At one end A of a diameter AB of a circle of radius 5 cm, tangent XAY is drawn to the circle. The length of the chord CD parallel to XY and at a distance 8 cm from A is
 (A) 4 cm (B) 5 cm
 (C) 6 cm (D) 8 cm

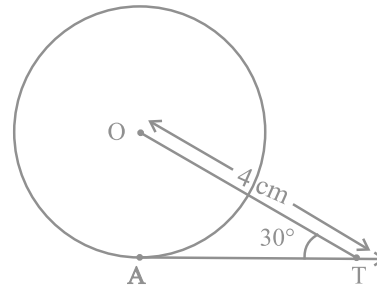

Fig. 9.5

6. In Fig. 9.5, AT is a tangent to the circle with centre O such that $OT = 4 \text{ cm}$ and $\angle OTA = 30^\circ$. Then AT is equal to
 (A) 4 cm (B) 2 cm
 (C) $2\sqrt{3} \text{ cm}$ (D) $4\sqrt{3} \text{ cm}$

7. In Fig. 9.6, if O is the centre of a circle, PQ is a chord and the tangent PR at P makes an angle of 50° with PQ, then $\angle POQ$ is equal to
 (A) 100° (B) 80°
 (C) 90° (D) 75°

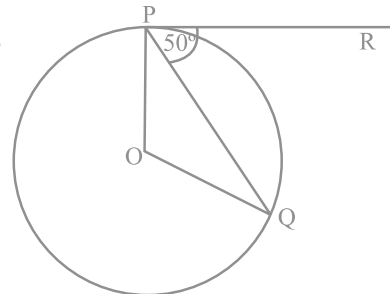

Fig. 9.6

8. In Fig. 9.7, if PA and PB are tangents to the circle with centre O such that $\angle APB = 50^\circ$, then $\angle OAB$ is equal to
 (A) 25° (B) 30°
 (C) 40° (D) 50°

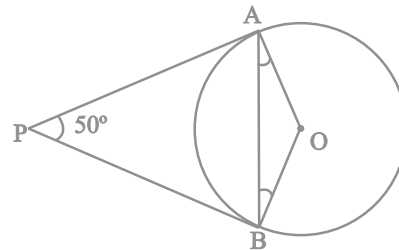

Fig. 9.7

9. If two tangents inclined at an angle 60° are drawn to a circle of radius 3 cm, then length of each tangent is equal to

- (A) $\frac{3}{2}\sqrt{3}$ cm (B) 6 cm
 (C) 3 cm (D) $3\sqrt{3}$ cm

10. In Fig. 9.8, if PQR is the tangent to a circle at Q whose centre is O, AB is a chord parallel to PR and $\angle BQR = 70^\circ$, then $\angle AQB$ is equal to

- (A) 20° (B) 40°
 (C) 35° (D) 45°

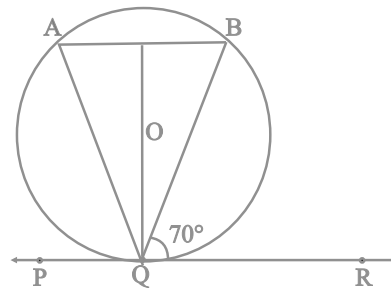

Fig. 9.8

(C) Short Answer Questions with Reasoning

Write 'True' or 'False' and give reasons for your answer.

Sample Question 1 : In Fig. 9.9, BOA is a diameter of a circle and the tangent at a point P meets BA extended at T. If $\angle PBO = 30^\circ$, then $\angle PTA$ is equal to 30° .

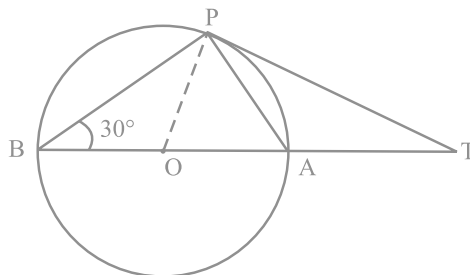

Fig. 9.9

Solution : True. As $\angle BPA = 90^\circ$, $\angle PAB = \angle OPA = 60^\circ$. Also, $OP \perp PT$. Therefore, $\angle APT = 30^\circ$ and $\angle PTA = 60^\circ - 30^\circ = 30^\circ$.

Sample Question 2 : In Fig. 9.10, PQL and PRM are tangents to the circle with centre O at the points Q and R, respectively and S is a point on the circle such that $\angle SQL = 50^\circ$ and $\angle SRM = 60^\circ$. Then $\angle QSR$ is equal to 40° .

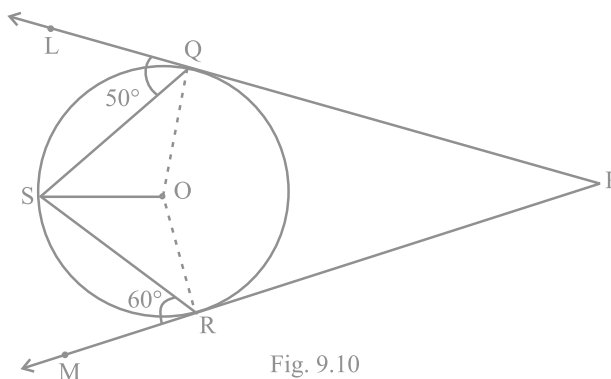

Fig. 9.10

Solution : False. Here $\angle OSQ = \angle OQS = 90^\circ - 50^\circ = 40^\circ$ and $\angle RSO = \angle SRO = 90^\circ - 60^\circ = 30^\circ$. Therefore, $\angle QSR = 40^\circ + 30^\circ = 70^\circ$.

EXERCISE 9.2

Write 'True' or 'False' and justify your answer in each of the following :

1. If a chord AB subtends an angle of 60° at the centre of a circle, then angle between the tangents at A and B is also 60° .
2. The length of tangent from an external point on a circle is always greater than the radius of the circle.
3. The length of tangent from an external point P on a circle with centre O is always less than OP.
4. The angle between two tangents to a circle may be 0° .
5. If angle between two tangents drawn from a point P to a circle of radius a and centre O is 90° , then $OP = a\sqrt{2}$.
6. If angle between two tangents drawn from a point P to a circle of radius a and centre O is 60° , then $OP = a\sqrt{3}$.
7. The tangent to the circumcircle of an isosceles triangle ABC at A, in which $AB = AC$, is parallel to BC.

8. If a number of circles touch a given line segment PQ at a point A, then their centres lie on the perpendicular bisector of PQ.
9. If a number of circles pass through the end points P and Q of a line segment PQ, then their centres lie on the perpendicular bisector of PQ.
10. AB is a diameter of a circle and AC is its chord such that $\angle BAC = 30^\circ$. If the tangent at C intersects AB extended at D, then $BC = BD$.

(D) Short Answer Questions

Sample Question 1 : If d_1, d_2 ($d_2 > d_1$) be the diameters of two concentric circles and c be the length of a chord of a circle which is tangent to the other circle, prove that $d_2^2 = c^2 + d_1^2$.

Solution : Let AB be a chord of a circle which touches the other circle at C. Then $\triangle OCB$ is right triangle (see Fig.9.11). By Pythagoras theorem $OC^2 + CB^2 = OB^2$.

$$\text{i.e., } \left(\frac{1}{2}d_1\right)^2 + \left(\frac{1}{2}c\right)^2 = \left(\frac{1}{2}d_2\right)^2$$

(As C bisects AB)

Therefore, $d_2^2 = c^2 + d_1^2$.

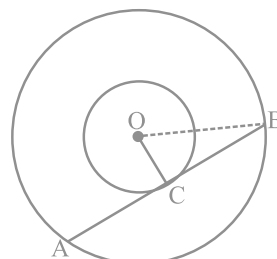

Fig. 9.11

Sample Question 2 : If a, b, c are the sides of a right triangle where c is the hypotenuse, prove that the radius r of the circle which touches the sides of the triangle is given by

$$r = \frac{a + b - c}{2}$$

Solution : Let the circle touches the sides BC, CA, AB of the right triangle ABC at D, E and F respectively, where $BC = a$, $CA = b$ and $AB = c$ (see Fig. 9.12). Then $AE = AF$ and $BD = BF$. Also $CE = CD = r$.

$$\text{i.e., } b - r = AF, \quad a - r = BF$$

$$\text{or } AB = c = AF + BF = b - r + a - r$$

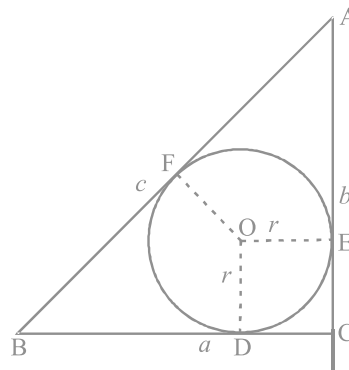

Fig. 9.12

This gives $r = \frac{a + b + c}{2}$

EXERCISE 9.3

1. Out of the two concentric circles, the radius of the outer circle is 5 cm and the chord AC of length 8 cm is a tangent to the inner circle. Find the radius of the inner circle.
2. Two tangents PQ and PR are drawn from an external point to a circle with centre O. Prove that QORP is a cyclic quadrilateral.
3. If from an external point B of a circle with centre O, two tangents BC and BD are drawn such that $\angle DBC = 120^\circ$, prove that $BC + BD = BO$, i.e., $BO = 2BC$.
4. Prove that the centre of a circle touching two intersecting lines lies on the angle bisector of the lines.

5. In Fig. 9.13, AB and CD are common tangents to two circles of unequal radii. Prove that $AB = CD$.

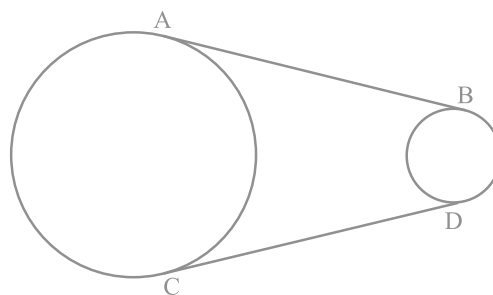

Fig. 9.13

6. In Question 5 above, if radii of the two circles are equal, prove that $AB = CD$.
7. In Fig. 9.14, common tangents AB and CD to two circles intersect at E. Prove that $AB = CD$.

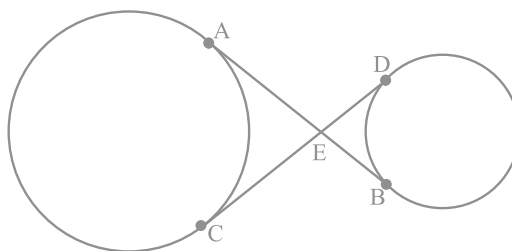

Fig. 9.14

8. A chord PQ of a circle is parallel to the tangent drawn at a point R of the circle. Prove that R bisects the arc PRQ.

9. Prove that the tangents drawn at the ends of a chord of a circle make equal angles with the chord.
10. Prove that a diameter AB of a circle bisects all those chords which are parallel to the tangent at the point A.

(E) Long Answer Questions

Sample Question 1 : In Fig. 9.15, from an external point P, a tangent PT and a line segment PAB is drawn to a circle with centre O. ON is perpendicular on the chord AB. Prove that :

- (i) $PA \cdot PB = PN^2 - AN^2$
- (ii) $PN^2 - AN^2 = OP^2 - OT^2$
- (iii) $PA \cdot PB = PT^2$

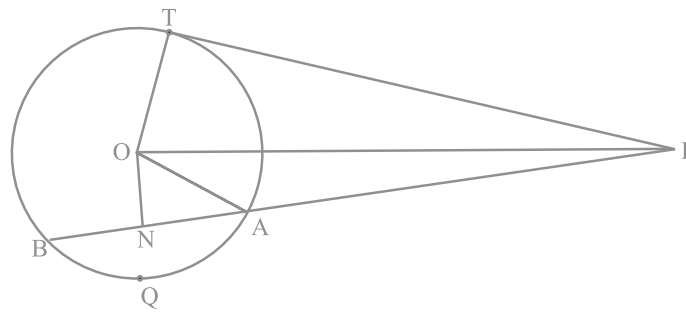

Fig. 9.15

Solution :

- (i) $PA \cdot PB = (PN - AN)(PN + AN)$
 $= (PN - AN)(PN + AN)$ (As $AN = BN$)
 $= PN^2 - AN^2$
- (ii) $PN^2 - AN^2 = (OP^2 - ON^2) - AN^2$ (As $ON \perp PN$)
 $= OP^2 - (ON^2 + AN^2)$
 $= OP^2 - OA^2$ (As $ON \perp AN$)
 $= OP^2 - OT^2$ (As $OA = OT$)

(iii) From (i) and (ii)

$$PA \cdot PB = OP^2 - OT^2$$

$$= PT^2$$

(As $\angle OTP = 90^\circ$)

Sample Question 2 : If a circle touches the side BC of a triangle ABC at P and extended sides AB and AC at Q and R, respectively, prove that $AQ = \frac{1}{2}(BC + CA + AB)$

Solution : See Fig. 9.16.

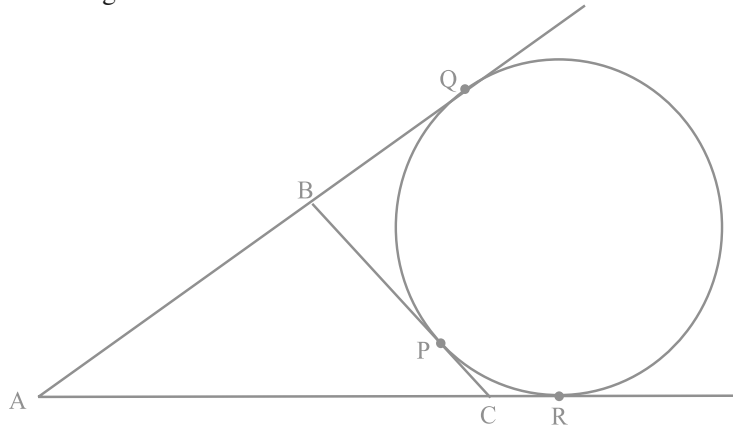

Fig. 9.16

By Theorem 10.2 of the textbook,

$$BQ = BP$$

$$CP = CR, \text{ and}$$

$$AQ = AR$$

Now,

$$2AQ = AQ + AR$$

$$= (AB + BQ) + (AC + CR)$$

$$= AB + BP + AC + CP$$

$$= (BP + CP) + AC + AB$$

$$= BC + CA + AB$$

$$\text{i.e., } AQ = \frac{1}{2}(BC + CA + AB).$$

EXERCISE 9.4

1. If a hexagon $ABCDEF$ circumscribe a circle, prove that $AB + CD + EF = BC + DE + FA$.
2. Let s denote the semi-perimeter of a triangle ABC in which $BC = a$, $CA = b$, $AB = c$. If a circle touches the sides BC , CA , AB at D , E , F , respectively, prove that $BD = s - b$.
3. From an external point P , two tangents, PA and PB are drawn to a circle with centre O . At one point E on the circle tangent is drawn which intersects PA and PB at C and D , respectively. If $PA = 10$ cm, find the the perimeter of the triangle PCD .
4. If AB is a chord of a circle with centre O , AOC is a diameter and AT is the tangent at A as shown in Fig. 9.17. Prove that $\angle BAT = \angle ACB$

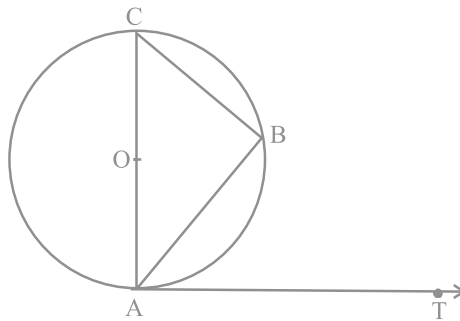

Fig. 9.17

5. Two circles with centres O and O' of radii 3 cm and 4 cm, respectively intersect at two points P and Q such that OP and $O'P$ are tangents to the two circles. Find the length of the common chord PQ .
6. In a right triangle ABC in which $\angle B = 90^\circ$, a circle is drawn with AB as diameter intersecting the hypotenuse AC at P . Prove that the tangent to the circle at P bisects BC .
7. In Fig. 9.18, tangents PQ and PR are drawn to a circle such that $\angle RPQ = 30^\circ$. A chord RS is drawn parallel to the tangent PQ . Find the $\angle RQS$.

[Hint: Draw a line through Q and perpendicular to QP.]

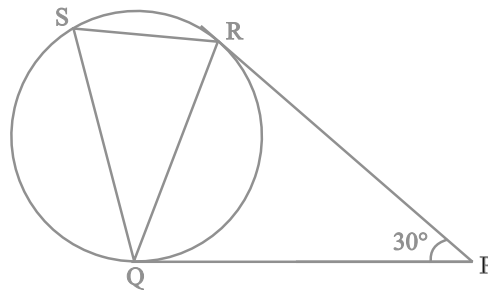

Fig. 9.18

8. AB is a diameter and AC is a chord of a circle with centre O such that $\angle BAC = 30^\circ$. The tangent at C intersects extended AB at a point D. Prove that $BC = BD$.
9. Prove that the tangent drawn at the mid-point of an arc of a circle is parallel to the chord joining the end points of the arc.
10. In Fig. 9.19, the common tangent, AB and CD to two circles with centres O and O' intersect at E. Prove that the points O, E, O' are collinear.

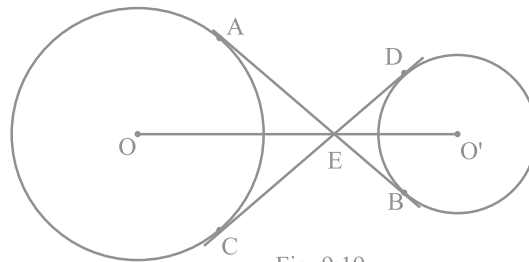

Fig. 9.19

11. In Fig. 9.20. O is the centre of a circle of radius 5 cm, T is a point such that $OT = 13$ cm and OT intersects the circle at E. If AB is the tangent to the circle at E, find the length of AB.

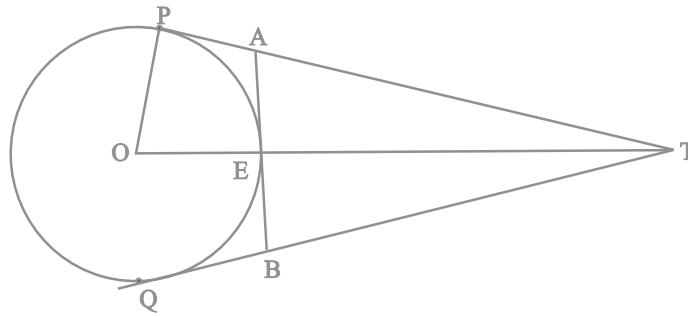

Fig. 9.20

12. The tangent at a point C of a circle and a diameter AB when extended intersect at P. If $\angle PCA = 110^\circ$, find $\angle CBA$ [see Fig. 9.21].

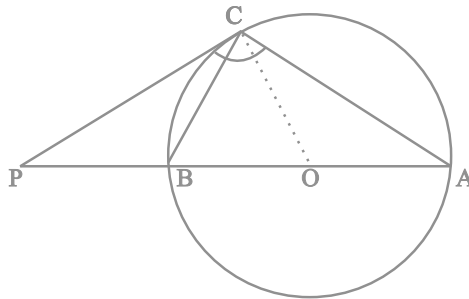

Fig. 9.21

[Hint: Join C with centre O.]

13. If an isosceles triangle ABC, in which $AB = AC = 6$ cm, is inscribed in a circle of radius 9 cm, find the area of the triangle.
14. A is a point at a distance 13 cm from the centre O of a circle of radius 5 cm. AP and AQ are the tangents to the circle at P and Q. If a tangent BC is drawn at a point R lying on the minor arc PQ to intersect AP at B and AQ at C, find the perimeter of the $\triangle ABC$.

EXERCISE 10.1

Choose the correct answer from the given four options:

1. To divide a line segment AB in the ratio 5:7, first a ray AX is drawn so that $\angle BAX$ is an acute angle and then at equal distances points are marked on the ray AX such that the minimum number of these points is
(A) 8 (B) 10 (C) 11 (D) 12
2. To divide a line segment AB in the ratio 4:7, a ray AX is drawn first such that $\angle BAX$ is an acute angle and then points A_1, A_2, A_3, \dots are located at equal distances on the ray AX and the point B is joined to
(A) A_{12} (B) A_{11} (C) A_{10} (D) A_9
3. To divide a line segment AB in the ratio 5 : 6, draw a ray AX such that $\angle BAX$ is an acute angle, then draw a ray BY parallel to AX and the points A_1, A_2, A_3, \dots and B_1, B_2, B_3, \dots are located at equal distances on ray AX and BY, respectively. Then the points joined are
(A) A_5 and B_6 (B) A_6 and B_5 (C) A_4 and B_5 (D) A_5 and B_4
4. To construct a triangle similar to a given $\triangle ABC$ with its sides $\frac{3}{7}$ of the corresponding sides of $\triangle ABC$, first draw a ray BX such that $\angle CBX$ is an acute angle and X lies on the opposite side of A with respect to BC. Then locate points B_1, B_2, B_3, \dots on BX at equal distances and next step is to join
(A) B_{10} to C (B) B_3 to C (C) B_7 to C (D) B_4 to C
5. To construct a triangle similar to a given $\triangle ABC$ with its sides $\frac{8}{5}$ of the corresponding sides of $\triangle ABC$ draw a ray BX such that $\angle CBX$ is an acute angle and X is on the opposite side of A with respect to BC. The minimum number of points to be located at equal distances on ray BX is
(A) 5 (B) 8 (C) 13 (D) 3
6. To draw a pair of tangents to a circle which are inclined to each other at an angle of 60° , it is required to draw tangents at end points of those two radii of the circle, the angle between them should be
(A) 135° (B) 90° (C) 60° (D) 120°

(C) Short Answer Questions with Reasoning

Write True or False and give reasons for your answer.

Sample Questions 1 : By geometrical construction, it is possible to divide a line segment in the ratio $2\sqrt{3}:2\sqrt{3}$.

Solution : False. As $2\sqrt{3}:2\sqrt{3}$ can be simplified as $4\sqrt{3}:1$ and $4\sqrt{3}$ is not a positive integer, while 1 is.

EXERCISE 10.2

Write True or False and give reasons for your answer in each of the following:

- By geometrical construction, it is possible to divide a line segment in the ratio $\sqrt{3}:\frac{1}{\sqrt{3}}$.
- To construct a triangle similar to a given $\triangle ABC$ with its sides $\frac{7}{3}$ of the corresponding sides of $\triangle ABC$, draw a ray BX making acute angle with BC and X lies on the opposite side of A with respect to BC . The points B_1, B_2, \dots, B_7 are located at equal distances on BX , B_3 is joined to C and then a line segment B_6C' is drawn parallel to B_3C where C' lies on BC produced. Finally, line segment $A'C'$ is drawn parallel to AC .
- A pair of tangents can be constructed from a point P to a circle of radius 3.5 cm situated at a distance of 3 cm from the centre.
- A pair of tangents can be constructed to a circle inclined at an angle of 170° .

(D) Short Answer Questions

Sample Question 1 : Draw an equilateral triangle ABC of each side 4 cm. Construct a triangle similar to it and of scale factor $\frac{3}{5}$. Is the new triangle also an equilateral?

Solution : Follow the similar steps as given in Mathematics Textbook for Class X. Yes, the new triangle is also equilateral.

EXERCISE 10.3

1. Draw a line segment of length 7 cm. Find a point P on it which divides it in the ratio 3:5.
2. Draw a right triangle ABC in which $BC = 12$ cm, $AB = 5$ cm and $\angle B = 90^\circ$. Construct a triangle similar to it and of scale factor $\frac{2}{3}$. Is the new triangle also a right triangle?
3. Draw a triangle ABC in which $BC = 6$ cm, $CA = 5$ cm and $AB = 4$ cm. Construct a triangle similar to it and of scale factor $\frac{5}{3}$.
4. Construct a tangent to a circle of radius 4 cm from a point which is at a distance of 6 cm from its centre.

(E) Long Answer Questions

Sample Questions 1 : Given a rhombus ABCD in which $AB = 4$ cm and $\angle ABC = 60^\circ$, divide it into two triangles say, ABC and ADC. Construct the triangle

$AB'C'$ similar to $\triangle ABC$ with scale factor $\frac{2}{3}$. Draw a line segment $C'D'$ parallel to CD

where D' lies on AD. Is $AB'C'D'$ a rhombus? Give reasons.

Solution : First draw the rhombus ABCD in which $AB = 4$ cm and $\angle ABC = 60^\circ$ as given in Fig. 10.1 and join AC. Construct the triangle $AB'C'$ similar to $\triangle ABC$ with scale factor $\frac{2}{3}$ as instructed in the Mathematics Textbook for Class X (See Fig. 10.1).

Finally draw the line segment $C'D'$ parallel to CD.

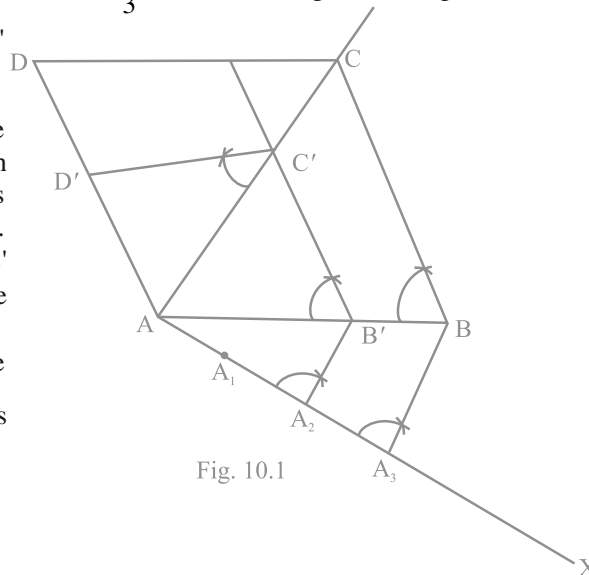

Fig. 10.1

Now
$$\frac{AB'}{AB} = \frac{2}{3} = \frac{A'C'}{AC}$$

Also
$$\frac{AC'}{AC} = \frac{C'D'}{CD} = \frac{AD'}{AD} = \frac{2}{3}$$

Therefore, $AB' = B'C' = C'D' = AD' = \frac{2}{3} AB$.

i.e., $AB'C'D'$ is a rhombus.

EXERCISE 10.4

- Two line segments AB and AC include an angle of 60° where $AB = 5$ cm and $AC = 7$ cm. Locate points P and Q on AB and AC , respectively such that $AP = \frac{3}{4} AB$ and $AQ = \frac{1}{4} AC$. Join P and Q and measure the length PQ .
- Draw a parallelogram $ABCD$ in which $BC = 5$ cm, $AB = 3$ cm and $\angle ABC = 60^\circ$, divide it into triangles BCD and ABD by the diagonal BD .
Construct the triangle $BD'C'$ similar to $\triangle BDC$ with scale factor $\frac{4}{3}$. Draw the line segment $D'A'$ parallel to DA where A' lies on extended side BA . Is $A'BC'D'$ a parallelogram?
- Draw two concentric circles of radii 3 cm and 5 cm. Taking a point on outer circle construct the pair of tangents to the other. Measure the length of a tangent and verify it by actual calculation.
- Draw an isosceles triangle ABC in which $AB = AC = 6$ cm and $BC = 5$ cm. Construct a triangle PQR similar to ABC in which $PQ = 8$ cm. Also justify the construction.
- Draw a triangle ABC in which $AB = 5$ cm, $BC = 6$ cm and $\angle ABC = 60^\circ$. Construct a triangle similar to ABC with scale factor $\frac{5}{7}$. Justify the construction.

6. Draw a circle of radius 4 cm. Construct a pair of tangents to it, the angle between which is 60° . Also justify the construction. Measure the distance between the centre of the circle and the point of intersection of tangents.
7. Draw a triangle ABC in which $AB = 4$ cm, $BC = 6$ cm and $AC = 9$ cm. Construct a triangle similar to $\triangle ABC$ with scale factor $\frac{3}{2}$. Justify the construction. Are the two triangles congruent? Note that all the three angles and two sides of the two triangles are equal.

AREA RELATED TO CIRCLES

(A) Main Concepts and Results

Perimeters and areas of simple closed figures. Circumference and area of a circle. Area of a circular path (i.e., ring). Sector of a circle and its central angle – Major and Minor sectors. Segment of a circle – Major and Minor segments.

- Circumference of a circle = $2 \pi r$ and area of a circle = πr^2 , where r is the radius of the circle.
- Area of the circular path formed by two concentric circles of radii r_1 and r_2 ($r_1 > r_2$) = $\pi r_1^2 - \pi r_2^2 = \pi(r_1^2 - r_2^2)$.
- Area of the sector of a circle of radius r with central angle $\theta = \frac{\theta}{360} \times \pi r^2$, where θ is measured in degrees.
- Length of the arc of the sector of a circle of radius r with central angle $\theta = \frac{\theta}{360} \times 2 \pi r$, where θ is measured in degrees.
- Area of the minor segment APB of the circle in Fig. 11.1 = area of sector OAPB – area of Δ OAB.
- Area of the major sector of a circle of radius r = πr^2 – area of the corresponding minor sector.

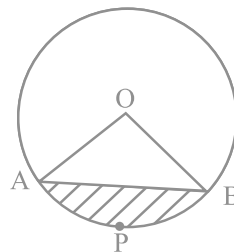

Fig. 11.1

- Area of the major segment of a circle of radius $r = \pi r^2 -$ area of the corresponding minor segment.

Note: Unless stated otherwise, the value of π is to be taken as $\frac{22}{7}$.

(B) Multiple Choice Questions

Choose the correct answer from the given four options:

Sample Question 1 : If the area of a circle is 154 cm^2 , then its perimeter is

- (A) 11 cm (B) 22 cm (C) 44 cm (D) 55 cm

Solution : Answer (C)

Sample Question 2 : If θ is the angle (in degrees) of a sector of a circle of radius r , then area of the sector is

- (A) $\frac{\pi r^2 \theta}{360}$ (B) $\frac{\pi r^2 \theta}{180}$ (C) $\frac{2 \pi r \theta}{360}$ (D) $\frac{2 \pi r \theta}{180}$

Solution : Answer (A)

EXERCISE 11.1

Choose the correct answer from the given four options:

- If the sum of the areas of two circles with radii R_1 and R_2 is equal to the area of a circle of radius R , then

(A) $R_1 + R_2 = R$ (B) $R_1^2 + R_2^2 = R^2$
 (C) $R_1 + R_2 < R$ (D) $R_1^2 + R_2^2 < R^2$
- If the sum of the circumferences of two circles with radii R_1 and R_2 is equal to the circumference of a circle of radius R , then

(A) $R_1 + R_2 = R$ (B) $R_1 + R_2 > R$
 (C) $R_1 + R_2 < R$ (D) Nothing definite can be said about the relation among R_1 , R_2 and R .

3. If the circumference of a circle and the perimeter of a square are equal, then
- (A) Area of the circle = Area of the square
 - (B) Area of the circle > Area of the square
 - (C) Area of the circle < Area of the square
 - (D) Nothing definite can be said about the relation between the areas of the circle and square.
4. Area of the largest triangle that can be inscribed in a semi-circle of radius r units is
- (A) r^2 sq. units
 - (B) $\frac{1}{2} r^2$ sq. units
 - (C) $2 r^2$ sq. units
 - (D) $\sqrt{2} r^2$ sq. units
5. If the perimeter of a circle is equal to that of a square, then the ratio of their areas is
- (A) 22 : 7
 - (B) 14 : 11
 - (C) 7 : 22
 - (D) 11 : 14
6. It is proposed to build a single circular park equal in area to the sum of areas of two circular parks of diameters 16 m and 12 m in a locality. The radius of the new park would be
- (A) 10 m
 - (B) 15 m
 - (C) 20 m
 - (D) 24 m
7. The area of the circle that can be inscribed in a square of side 6 cm is
- (A) $36 \pi \text{ cm}^2$
 - (B) $18 \pi \text{ cm}^2$
 - (C) $12 \pi \text{ cm}^2$
 - (D) $9 \pi \text{ cm}^2$
8. The area of the square that can be inscribed in a circle of radius 8 cm is
- (A) 256 cm^2
 - (B) 128 cm^2
 - (C) $64\sqrt{2} \text{ cm}^2$
 - (D) 64 cm^2
9. The radius of a circle whose circumference is equal to the sum of the circumferences of the two circles of diameters 36cm and 20 cm is
- (A) 56 cm
 - (B) 42 cm
 - (C) 28 cm
 - (D) 16 cm
10. The diameter of a circle whose area is equal to the sum of the areas of the two circles of radii 24 cm and 7 cm is
- (A) 31 cm
 - (B) 25 cm
 - (C) 62 cm
 - (D) 50 cm

(C) Short Answer Questions with Reasoning

Sample Question 1 : Is the following statement true? Give reasons for your answer.

Area of a segment of a circle = area of the corresponding sector – area of the corresponding triangle.

Solution : Statement is not true. It is true only for a minor segment. In the case of a major segment, area of the triangle will have to be added to the corresponding area of the sector.

Sample Question 2 : In Fig. 11.2, a circle is inscribed in a square of side 5 cm and another circle is circumscribing the square. Is it true to say that area of the outer circle is two times the area of the inner circle? Give reasons for your answer.

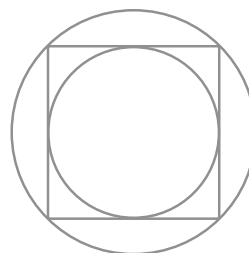

Fig.11.2

Solution : It is true, because diameter of the inner circle = 5 cm and that of outer circle = diagonal of the square = $5\sqrt{2}$ cm.

$$\text{So, } A_1 = \pi \left(\frac{5\sqrt{2}}{2} \right)^2 \text{ and } A_2 = \pi \left(\frac{5}{2} \right)^2, \text{ giving } \frac{A_1}{A_2} = 2$$

EXERCISE 11.2

1. Is the area of the circle inscribed in a square of side a cm, $\pi a^2 \text{ cm}^2$? Give reasons for your answer.
2. Will it be true to say that the perimeter of a square circumscribing a circle of radius a cm is $8a$ cm? Give reasons for your answer.
3. In Fig 11.3, a square is inscribed in a circle of diameter d and another square is circumscribing the circle. Is the area of the outer square four times the area of the inner square? Give reasons for your answer.

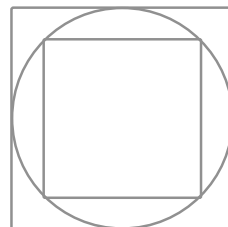

Fig.11.3

4. Is it true to say that area of a segment of a circle is less than the area of its corresponding sector? Why?
5. Is it true that the distance travelled by a circular wheel of diameter d cm in one revolution is $2\pi d$ cm? Why?
6. In covering a distance s metres, a circular wheel of radius r metres makes $\frac{s}{2\pi r}$ revolutions. Is this statement true? Why?
7. The numerical value of the area of a circle is greater than the numerical value of its circumference. Is this statement true? Why?
8. If the length of an arc of a circle of radius r is equal to that of an arc of a circle of radius $2r$, then the angle of the corresponding sector of the first circle is double the angle of the corresponding sector of the other circle. Is this statement false? Why?
9. The areas of two sectors of two different circles with equal corresponding arc lengths are equal. Is this statement true? Why?
10. The areas of two sectors of two different circles are equal. Is it necessary that their corresponding arc lengths are equal? Why?
11. Is the area of the largest circle that can be drawn inside a rectangle of length a cm and breadth b cm ($a > b$) is πb^2 cm²? Why?
12. Circumferences of two circles are equal. Is it necessary that their areas be equal? Why?
13. Areas of two circles are equal. Is it necessary that their circumferences are equal? Why?
14. Is it true to say that area of a square inscribed in a circle of diameter p cm is p^2 cm²? Why?

(D) Short Answer Questions

Sample Question 1: Find the diameter of the circle whose area is equal to the sum of the areas of the two circles of diameters 20 cm and 48 cm.

Solution : Here, radius r_1 of first circle = $\frac{20}{2}$ cm = 10 cm and radius r_2 of the second circle = $\frac{48}{2}$ cm = 24 cm

Therefore, sum of their areas = $\pi r_1^2 + \pi r_2^2 = \pi (10)^2 + \pi (24)^2 = \pi \times 676$ (1)

Let the radius of the new circle be r cm. Its area = πr^2 (2)

Therefore, from (1) and (2),

$$\pi r^2 = \pi \times 676$$

or $r^2 = 676$

i.e., $r = 26$

Thus, radius of the new circle = 26 cm

Hence, diameter of the new circle = 2×26 cm = 52 cm

Sample Question 2 : Find the area of a sector of circle of radius 21 cm and central angle 120° .

Solution : Area of the sector = $\frac{\theta}{360} \times \pi r^2$

$$\begin{aligned} &= \frac{120}{360} \times \frac{22}{7} \times (21)^2 \text{ cm}^2 \\ &= 22 \times 21 \text{ cm}^2 \\ &= 462 \text{ cm}^2 \end{aligned}$$

Sample Question 3 : In Fig 11.4, a circle of radius 7.5 cm is inscribed in a square. Find the area of the shaded region (Use $\pi = 3.14$)

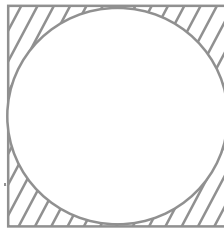

Fig.11.4

Solution : Area of the circle = πr^2
 $= 3.14 \times (7.5)^2 \text{ cm}^2$
 $= 176.625 \text{ cm}^2$

Clearly, side of the square = diameter of the circle = 15 cm

So, area of the square = $15^2 \text{ cm}^2 = 225 \text{ cm}^2$

Therefore, area of the shaded region

$$= 225 \text{ cm}^2 - 176.625 \text{ cm}^2 = 48.375 \text{ cm}^2$$

Sample Question 4 : Area of a sector of a circle of radius 36 cm is $54 \pi \text{ cm}^2$. Find the length of the corresponding arc of the sector.

Solution : Let the central angle (in degrees) be θ .

So,
$$\frac{\pi \times (36)^2 \theta}{360} = 54 \pi$$

or
$$\theta = \frac{54 \times 360}{36 \times 36} = 15$$

Now, length of the arc = $\frac{\theta}{360} \times 2\pi r$
 $= \frac{15}{360} \times 2\pi \times 36 \text{ cm}$
 $= 3 \pi \text{ cm}$

EXERCISE 11.3

- Find the radius of a circle whose circumference is equal to the sum of the circumferences of two circles of radii 15 cm and 18 cm.
- In Fig. 11.5, a square of diagonal 8 cm is inscribed in a circle. Find the area of the shaded region.

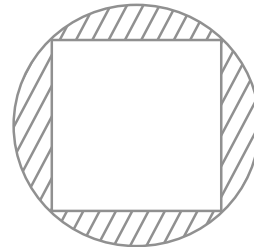

Fig.11.5

3. Find the area of a sector of a circle of radius 28 cm and central angle 45° .
4. The wheel of a motor cycle is of radius 35 cm. How many revolutions per minute must the wheel make so as to keep a speed of 66 km/h?
5. A cow is tied with a rope of length 14 m at the corner of a rectangular field of dimensions $20\text{m} \times 16\text{m}$. Find the area of the field in which the cow can graze.
6. Find the area of the flower bed (with semi-circular ends) shown in Fig. 11.6.

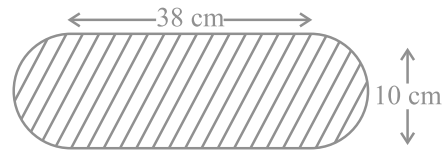

Fig. 11.6

7. In Fig. 11.7, AB is a diameter of the circle, $AC = 6\text{ cm}$ and $BC = 8\text{ cm}$. Find the area of the shaded region (Use $\pi = 3.14$).

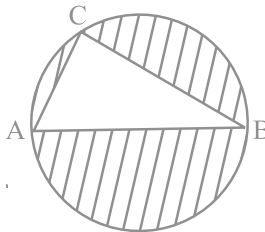

Fig. 11.7

8. Find the area of the shaded field shown in Fig. 11.8.

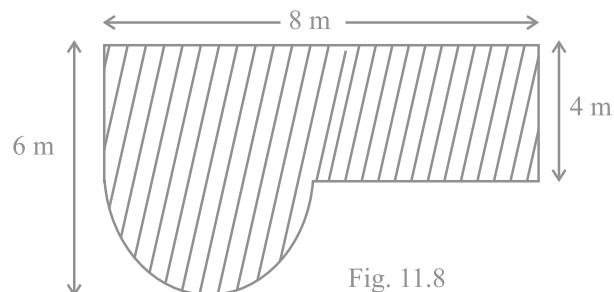

Fig. 11.8

9. Find the area of the shaded region in Fig. 11.9.

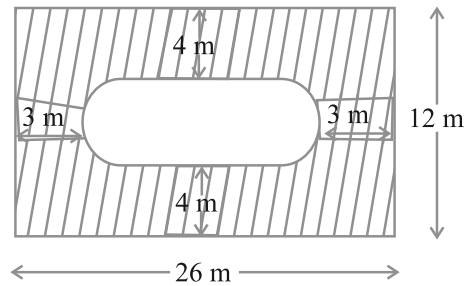

Fig. 11.9

10. Find the area of the minor segment of a circle of radius 14 cm, when the angle of the corresponding sector is 60° .
11. Find the area of the shaded region in Fig. 11.10, where arcs drawn with centres A, B, C and D intersect in pairs at mid-points P, Q, R and S of the sides AB, BC, CD and DA, respectively of a square ABCD (Use $\pi = 3.14$).

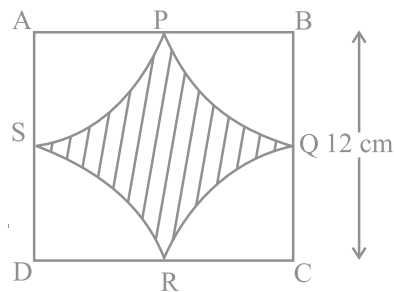

Fig. 11.10

12. In Fig. 11.11, arcs are drawn by taking vertices A, B and C of an equilateral triangle of side 10 cm. to intersect the sides BC, CA and AB at their respective mid-points D, E and F. Find the area of the shaded region (Use $\pi = 3.14$).

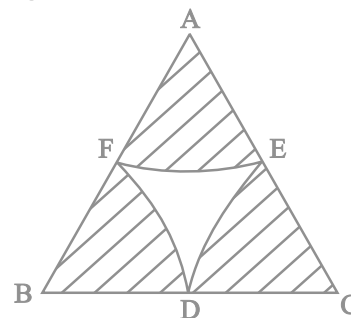

Fig. 11.11

13. In Fig. 11.12, arcs have been drawn with radii 14 cm each and with centres P, Q and R. Find the area of the shaded region.

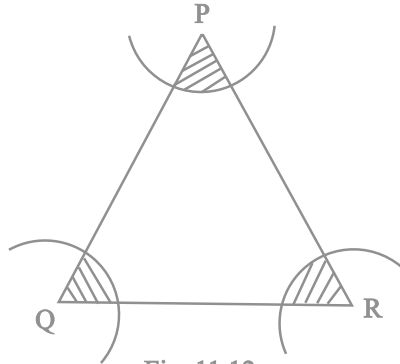

Fig. 11.12

14. A circular park is surrounded by a road 21 m wide. If the radius of the park is 105 m, find the area of the road.
15. In Fig. 11.13, arcs have been drawn of radius 21 cm each with vertices A, B, C and D of quadrilateral ABCD as centres. Find the area of the shaded region.

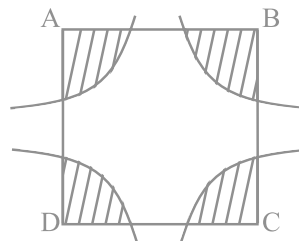

Fig. 11.13

16. A piece of wire 20 cm long is bent into the form of an arc of a circle subtending an angle of 60° at its centre. Find the radius of the circle.

(E) Long Answer Questions

Sample Question 1 : A chord of a circle of radius 20 cm subtends an angle of 90° at the centre. Find the area of the corresponding major segment of the circle. (Use $\pi = 3.14$).

Solution : Let AB be the chord of a circle of radius 10 cm, with O as the centre of the circle (see Fig. 11.14).

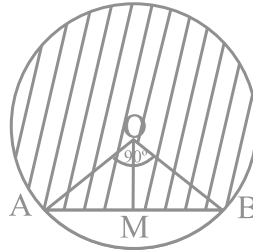

Fig. 11.14

Here, $\angle A O B = 90^\circ$ and we have to find the area of the major segment (which is shaded). As $\angle A O B = 90^\circ$, therefore angle of the major sector = $360^\circ - 90^\circ = 270^\circ$

$$\begin{aligned} \text{So, area of the major sector} &= \frac{270}{360} \times \pi \times (10)^2 \text{ cm}^2 \\ &= \frac{3}{4} \times 3.14 \times 100 \text{ cm}^2 \\ &= 75 \times 3.14 \text{ cm}^2 = 235.5 \text{ cm}^2 \end{aligned}$$

Now, to find the area of ΔOAB , draw $OM \perp AB$.

$$\text{So, } AM = \frac{1}{2} AB \text{ and } \angle AOM = \frac{1}{2} \times 90^\circ = 45^\circ.$$

$$\text{Now, } \frac{AM}{OA} = \sin 45^\circ = \frac{1}{\sqrt{2}}$$

$$\text{So, } AM = 10 \times \frac{1}{\sqrt{2}} \text{ cm.}$$

$$\text{Therefore, } AB = 10\sqrt{2} \text{ cm and } OM = OA \cos 45^\circ = 10 \times \frac{1}{\sqrt{2}} \text{ cm} = 5\sqrt{2} \text{ cm}$$

$$\text{So, area of } \Delta OAB = \frac{1}{2} \text{ base} \times \text{height}$$

$$= \frac{1}{2} 10\sqrt{2} \times 5\sqrt{2} \text{ cm}^2 = 50 \text{ cm}^2$$

Therefore, the area of the required major segment
 $= 235.5 \text{ cm}^2 + 50 \text{ cm}^2 = 285.5 \text{ cm}^2$

Another method for the area of ΔOAB

As, $\angle AOB = 90^\circ$,

Therefore, area of $\Delta OAB = \frac{1}{2} OA \times OB$

$$= \frac{1}{2} 10 \times 10 \text{ cm}^2 = 50 \text{ cm}^2$$

Sample Question 2 : With the vertices A, B and C of a triangle ABC as centres, arcs are drawn with radii 5 cm each as shown in Fig. 11.15. If $AB = 14 \text{ cm}$, $BC = 48 \text{ cm}$ and $CA = 50 \text{ cm}$, then find the area of the shaded region. (Use $\pi = 3.14$).

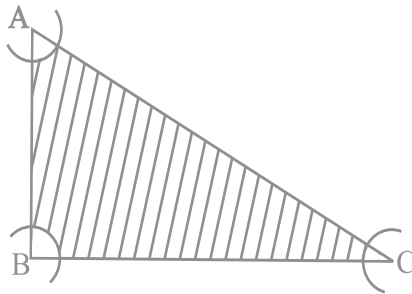

Fig. 11.15

Solution : Area of the sector with angle A

$$= \frac{\angle A}{360^\circ} \times \pi r^2 = \frac{\angle A}{360^\circ} \times \pi \times (5)^2 \text{ cm}^2$$

Area of the sector with angle B

$$= \frac{\angle B}{360^\circ} \times \pi r^2 = \frac{\angle B}{360^\circ} \times \pi \times (5)^2 \text{ cm}^2$$

and the area of the sector with angle C = $\frac{\angle C}{360^\circ} \times \pi \times (5)^2 \text{ cm}^2$

Therefore, sum of the areas (in cm^2) of the three sectors

$$\begin{aligned} &= \frac{\angle A}{360^\circ} \times \pi \times (5)^2 + \frac{\angle B}{360^\circ} \times \pi \times (5)^2 + \frac{\angle C}{360^\circ} \times \pi \times (5)^2 \\ &= \frac{\angle A + \angle B + \angle C}{360^\circ} \times 25 \pi \\ &= \frac{180^\circ}{360^\circ} \times 25 \pi \text{ cm}^2 \quad (\text{Because } \angle A + \angle B + \angle C = 180^\circ) \\ &= 25 \times \frac{\pi}{2} \text{ cm}^2 = 25 \times 1.57 \text{ cm}^2 = 39.25 \text{ cm}^2 \end{aligned}$$

Now, to find area of ΔABC , we find

$$s = \frac{a + b + c}{2} = \frac{48 + 50 + 14}{2} \text{ cm} = 56 \text{ cm}$$

By Heron's Formula,

$$\begin{aligned} \text{ar (ABC)} &= \sqrt{s(s-a)(s-b)(s-c)} \\ &= \sqrt{56 \times 8 \times 6 \times 42} \text{ cm}^2 \\ &= 336 \text{ cm}^2 \end{aligned}$$

So, area of the shaded region = area of the ΔABC – area of the three sectors
 $= (336 - 39.25) \text{ cm}^2 = 296.75 \text{ cm}^2$

Alternate Method for ar (ABC)

Here, $AB^2 + BC^2 = (14)^2 + (48)^2 = 2500 = (50)^2 = (CA)^2$

So, $\angle B = 90^\circ$ (By converse of Pythagoras Theorem)

Therefore, $\text{ar (ABC)} = \frac{1}{2} AB \times BC = \frac{1}{2} \times 14 \times 48 \text{ cm}^2 = 336 \text{ cm}^2$

Sample Question 3 : A calf is tied with a rope of length 6 m at the corner of a square grassy lawn of side 20 m. If the length of the rope is increased by 5.5m, find the increase in area of the grassy lawn in which the calf can graze.

Solution : Let the calf be tied at the corner A of the square lawn (see Fig. 11.16)

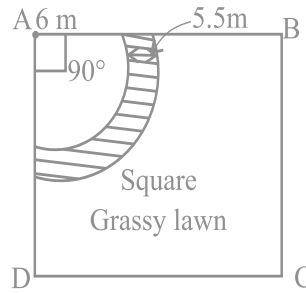

Fig. 11.16

Then, the increase in area = Difference of the two sectors of central angle 90° each and radii 11.5 m (6 m + 5.5 m) and 6 m, which is the shaded region in the figure.

So, required increase in area

$$\begin{aligned}
 &= \left[\frac{90}{360} \times \pi \times 11.5^2 - \frac{90}{360} \pi \times 6^2 \right] \text{m}^2 \\
 &= \frac{\pi}{4} \times (11.5 + 6) (11.5 - 6) \text{m}^2 \\
 &= \frac{22}{7 \times 4} \times 17.5 \times 5.5 \text{m}^2 \\
 &= 75.625 \text{m}^2 .
 \end{aligned}$$

EXERCISE 11.4

1. The area of a circular playground is 22176 m^2 . Find the cost of fencing this ground at the rate of Rs 50 per metre.
2. The diameters of front and rear wheels of a tractor are 80 cm and 2 m respectively. Find the number of revolutions that rear wheel will make in covering a distance in which the front wheel makes 1400 revolutions.
3. Sides of a triangular field are 15 m, 16 m and 17 m. With the three corners of the field a cow, a buffalo and a horse are tied separately with ropes of length 7 m each to graze in the field. Find the area of the field which cannot be grazed by the three animals.

4. Find the area of the segment of a circle of radius 12 cm whose corresponding sector has a central angle of 60° (Use $\pi = 3.14$).
5. A circular pond is 17.5 m in diameter. It is surrounded by a 2 m wide path. Find the cost of constructing the path at the rate of Rs 25 per m^2 .
6. In Fig. 11.17, ABCD is a trapezium with $AB \parallel DC$, $AB = 18$ cm, $DC = 32$ cm and distance between AB and DC = 14 cm. If arcs of equal radii 7 cm with centres A, B, C and D have been drawn, then find the area of the shaded region of the figure.

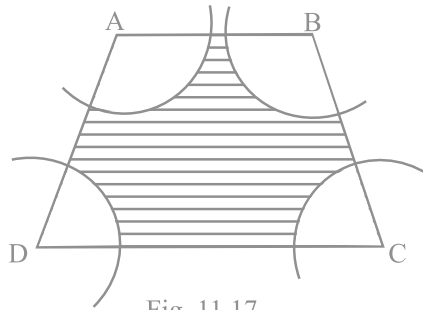

Fig. 11.17

7. Three circles each of radius 3.5 cm are drawn in such a way that each of them touches the other two. Find the area enclosed between these circles.
8. Find the area of the sector of a circle of radius 5 cm, if the corresponding arc length is 3.5 cm.
9. Four circular cardboard pieces of radii 7 cm are placed on a paper in such a way that each piece touches other two pieces. Find the area of the portion enclosed between these pieces.
10. On a square cardboard sheet of area 784 cm^2 , four congruent circular plates of maximum size are placed such that each circular plate touches the other two plates and each side of the square sheet is tangent to two circular plates. Find the area of the square sheet not covered by the circular plates.
11. Floor of a room is of dimensions $5 \text{ m} \times 4 \text{ m}$ and it is covered with circular tiles of diameters 50 cm each as shown in Fig. 11.18. Find the area of floor

that remains uncovered with tiles. (Use $\pi = 3.14$)

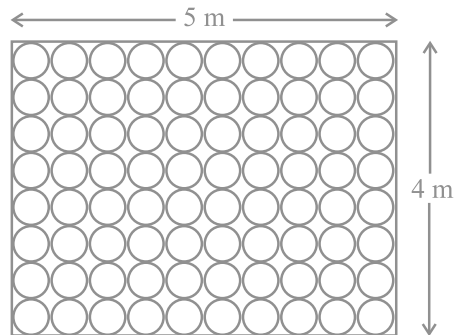

Fig. 11.18

12. All the vertices of a rhombus lie on a circle. Find the area of the rhombus, if area of the circle is 1256 cm^2 . (Use $\pi = 3.14$).
13. An archery target has three regions formed by three concentric circles as shown in Fig. 11.19. If the diameters of the concentric circles are in the ratio 1 : 2 : 3, then find the ratio of the areas of three regions.

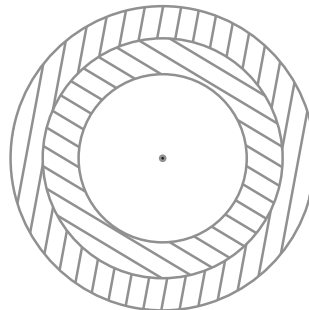

Fig. 11.19

14. The length of the minute hand of a clock is 5 cm. Find the area swept by the minute hand during the time period 6 : 05 a.m. and 6 : 40 a.m.
15. Area of a sector of central angle 200° of a circle is 770 cm^2 . Find the length of the corresponding arc of this sector.

16. The central angles of two sectors of circles of radii 7 cm and 21 cm are respectively 120° and 40° . Find the areas of the two sectors as well as the lengths of the corresponding arcs. What do you observe?
17. Find the area of the shaded region given in Fig. 11.20.

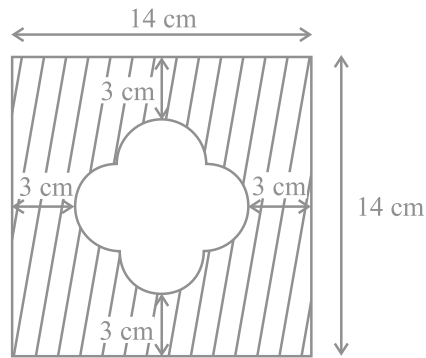

Fig. 11.20

18. Find the number of revolutions made by a circular wheel of area 1.54 m^2 in rolling a distance of 176 m.
19. Find the difference of the areas of two segments of a circle formed by a chord of length 5 cm subtending an angle of 90° at the centre.
20. Find the difference of the areas of a sector of angle 120° and its corresponding major sector of a circle of radius 21 cm.

SURFACE AREAS AND VOLUMES

(A) Main Concepts and Results

- The surface area of an object formed by combining any two of the basic solids, namely, cuboid, cone, cylinder, sphere and hemisphere.
- The volume of an object formed by combining any two of the basic solids namely, cuboid, cone, cylinder, sphere and hemisphere.
- The formulae involving the frustum of a cone are:
 - (i) Volume of the frustum of the cone = $\frac{1}{3} h[r_1^2 + r_2^2 + r_1r_2]$
 - (ii) Curved surface area of the frustum of the cone = $\pi(r_1+r_2)l$,
 - (iii) Total surface area of the frustum of the solid cone = $\pi l(r_1+r_2) + r_1^2 + r_2^2$, where $l = \sqrt{h^2 + (r_1 - r_2)^2}$,
 h = vertical height of the frustum, l = slant height of the frustum and r_1 and r_2 are radii of the two bases (ends) of the frustum.
- Solid hemisphere: If r is the radius of a hemisphere, then
 curved surface area = $2\pi r^2$
 total surface area = $3\pi r^2$, and volume = $\frac{2}{3} r^3$
- Volume of a spherical shell = $\frac{4}{3}\pi(r_1^3 - r_2^3)$, where r_1 and r_2 are respectively its external and internal radii.
 Throughout this chapter, take $\frac{22}{7}$, if not stated otherwise.

(B) Multiple Choice Questions :

Choose the correct answer from the given four options:

Sample Question 1 : A funnel (see Fig.12.1) is the combination of



Fig. 12.1

- (A) a cone and a cylinder (B) frustum of a cone and a cylinder
(C) a hemisphere and a cylinder (D) a hemisphere and a cone

Solution : Answer (B)

Sample Question 2 : If a marble of radius 2.1 cm is put into a cylindrical cup full of water of radius 5cm and height 6 cm, then how much water flows out of the cylindrical cup?

- (A) 38.8 cm³ (B) 55.4 cm³ (C) 19.4 cm³ (D) 471.4 cm³

Solution : Answer (A)

Sample Question 3 : A cubical ice cream brick of edge 22 cm is to be distributed among some children by filling ice cream cones of radius 2 cm and height 7 cm upto its brim. How many children will get the ice cream cones?

- (A) 163 (B) 263 (C) 363 (D) 463

Solution : Answer (C)

Sample Question 4 : The radii of the ends of a frustum of a cone of height h cm are r_1 cm and r_2 cm. The volume in cm³ of the frustum of the cone is

- (A) $\frac{1}{3} h[r_1^2 + r_2^2 + r_1 r_2]$ (B) $\frac{1}{3} h[r_1^2 + r_2^2 - r_1 r_2]$
(C) $\frac{1}{3} h[r_1^2 - r_2^2 + r_1 r_2]$ (D) $\frac{1}{3} h[r_1^2 - r_2^2 - r_1 r_2]$

Solution : Answer (A)

Sample Question 5 : The volume of the largest right circular cone that can be cut out from a cube of edge 4.2 cm is

- (A) 9.7 cm³ (B) 77.6 cm³ (C) 58.2 cm³ (D) 19.4 cm³

Solution : Answer (D)

EXERCISE 12.1

Choose the correct answer from the given four options:

1. A cylindrical pencil sharpened at one edge is the combination of

(A) a cone and a cylinder	(B) frustum of a cone and a cylinder
(C) a hemisphere and a cylinder	(D) two cylinders.
2. A *surahi* is the combination of

(A) a sphere and a cylinder	(B) a hemisphere and a cylinder
(C) two hemispheres	(D) a cylinder and a cone.
3. A plumbline (*sahul*) is the combination of (see Fig. 12.2)



Fig. 12.2

- | | |
|--------------------------------------|-----------------------------|
| (A) a cone and a cylinder | (B) a hemisphere and a cone |
| (C) frustum of a cone and a cylinder | (D) sphere and cylinder |
4. The shape of a glass (tumbler) (see Fig. 12.3) is usually in the form of

(A) a cone	(B) frustum of a cone
(C) a cylinder	(D) a sphere



Fig. 12.3

5. The shape of a *gilli*, in the *gilli-danda* game (see Fig. 12.4), is a combination of
- | | |
|------------------------------|------------------------------|
| (A) two cylinders | (B) a cone and a cylinder |
| (C) two cones and a cylinder | (D) two cylinders and a cone |



Fig. 12.4

6. A shuttle cock used for playing badminton has the shape of the combination of
- | | |
|-----------------------------|--|
| (A) a cylinder and a sphere | (B) a cylinder and a hemisphere |
| (C) a sphere and a cone | (D) frustum of a cone and a hemisphere |
7. A cone is cut through a plane parallel to its base and then the cone that is formed on one side of that plane is removed. The new part that is left over on the other side of the plane is called
- | | |
|-------------------------|------------|
| (A) a frustum of a cone | (B) cone |
| (C) cylinder | (D) sphere |
8. A hollow cube of internal edge 22cm is filled with spherical marbles of diameter 0.5 cm and it is assumed that $\frac{1}{8}$ space of the cube remains unfilled. Then the number of marbles that the cube can accommodate is
- | | | |
|------------|------------|------------|
| (A) 142296 | (B) 142396 | (C) 142496 |
| (D) 142596 | | |
9. A metallic spherical shell of internal and external diameters 4 cm and 8 cm, respectively is melted and recast into the form a cone of base diameter 8cm. The height of the cone is
- | | | | |
|----------|----------|----------|----------|
| (A) 12cm | (B) 14cm | (C) 15cm | (D) 18cm |
|----------|----------|----------|----------|
10. A solid piece of iron in the form of a cuboid of dimensions 49cm \times 33cm \times 24cm, is moulded to form a solid sphere. The radius of the sphere is
- | | | | |
|----------|----------|----------|----------|
| (A) 21cm | (B) 23cm | (C) 25cm | (D) 19cm |
|----------|----------|----------|----------|
11. A mason constructs a wall of dimensions 270cm \times 300cm \times 350cm with the bricks each of size 22.5cm \times 11.25cm \times 8.75cm and it is assumed that $\frac{1}{8}$ space is

covered by the mortar. Then the number of bricks used to construct the wall is

- (A) 11100 (B) 11200 (C) 11000 (D) 11300

12. Twelve solid spheres of the same size are made by melting a solid metallic cylinder of base diameter 2 cm and height 16 cm. The diameter of each sphere is
(A) 4 cm (B) 3 cm (C) 2 cm (D) 6 cm
13. The radii of the top and bottom of a bucket of slant height 45 cm are 28 cm and 7 cm, respectively. The curved surface area of the bucket is
(A) 4950 cm² (B) 4951 cm² (C) 4952 cm² (D) 4953 cm²
14. A medicine-capsule is in the shape of a cylinder of diameter 0.5 cm with two hemispheres stuck to each of its ends. The length of entire capsule is 2 cm. The capacity of the capsule is
(A) 0.36 cm³ (B) 0.35 cm³ (C) 0.34 cm³ (D) 0.33 cm³
15. If two solid hemispheres of same base radius r are joined together along their bases, then curved surface area of this new solid is
(A) $4\pi r^2$ (B) $6\pi r^2$ (C) $3\pi r^2$ (D) $8\pi r^2$
16. A right circular cylinder of radius r cm and height h cm ($h > 2r$) just encloses a sphere of diameter
(A) r cm (B) $2r$ cm (C) h cm (D) $2h$ cm
17. During conversion of a solid from one shape to another, the volume of the new shape will
(A) increase (B) decrease (C) remain unaltered (D) be doubled
18. The diameters of the two circular ends of the bucket are 44 cm and 24 cm. The height of the bucket is 35 cm. The capacity of the bucket is
(A) 32.7 litres (B) 33.7 litres (C) 34.7 litres (D) 31.7 litres
19. In a right circular cone, the cross-section made by a plane parallel to the base is a
(A) circle (B) frustum of a cone (C) sphere (D) hemisphere
20. Volumes of two spheres are in the ratio 64:27. The ratio of their surface areas is
(A) 3 : 4 (B) 4 : 3 (C) 9 : 16 (D) 16 : 9

(C) Short Answer Questions with Reasoning

Write 'True' or 'False' and justify your answer.

Sample Question 1 : If a solid cone of base radius r and height h is placed over a solid cylinder having same base radius and height as that of the cone, then the curved surface area of the shape is $\pi r\sqrt{h^2 + r^2} + 2\pi rh$.

Solution : True. Since the curved surface area taken together is same as the sum of curved surface areas measured separately.

Sample Question 2 : A spherical steel ball is melted to make eight new identical balls.

Then, the radius of each new ball be $\frac{1}{8}$ th the radius of the original ball.

Solution : False. Let r be the radius of the original steel ball and r_1 be the radius of the new ball formed after melting.

Therefore, $\frac{4}{3}\pi r^3 = 8 \times \frac{4}{3}\pi r_1^3$. This implies $r_1 = \frac{r}{2}$.

Sample Question 3 : Two identical solid cubes of side a are joined end to end. Then the total surface area of the resulting cuboid is $12a^2$.

Solution : False. The total surface area of a cube having side a is $6a^2$. If two identical faces of side a are joined together, then the total surface area of the cuboid so formed is $10a^2$.

Sample Question 4 : Total surface area of a *lattu* (top) as shown in the Fig. 12.5 is the sum of total surface area of hemisphere and the total surface area of cone.

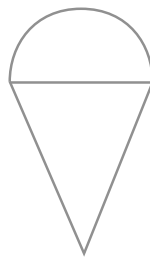

Fig. 12.5

Solution : False. Total surface area of the lattu is the sum of the curved surface area of the hemisphere and curved surface area of the cone.

Sample Question 5 : Actual capacity of a vessel as shown in the Fig. 12.6 is equal to the difference of volume of the cylinder and volume of the hemisphere.

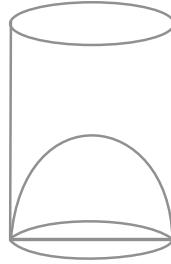

Fig. 12.6

Solution : True. Actual capacity of the vessel is the empty space inside the glass that can accommodate something when poured in it.

EXERCISE 12.2

Write 'True' or 'False' and justify your answer in the following:

- Two identical solid hemispheres of equal base radius r cm are stuck together along their bases. The total surface area of the combination is $6\pi r^2$.
- A solid cylinder of radius r and height h is placed over other cylinder of same height and radius. The total surface area of the shape so formed is $4\pi rh + 4\pi r^2$.
- A solid cone of radius r and height h is placed over a solid cylinder having same base radius and height as that of a cone. The total surface area of the combined solid is $\pi r \left[\sqrt{r^2 + h^2} + 3r + 2h \right]$.
- A solid ball is exactly fitted inside the cubical box of side a . The volume of the ball is $\frac{4}{3}\pi a^3$.
- The volume of the frustum of a cone is $\frac{1}{3}\pi h[r_1^2 + r_2^2 + r_1r_2]$, where h is vertical height of the frustum and r_1, r_2 are the radii of the ends.
- The capacity of a cylindrical vessel with a hemispherical portion raised upward at the bottom as shown in the Fig. 12.7 is $\frac{r^2}{3}(3h - 2r)$.

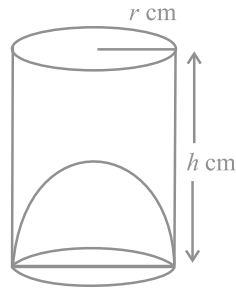

Fig. 12.7

7. The curved surface area of a frustum of a cone is $\pi l (r_1 + r_2)$, where $l = \sqrt{h^2 + (r_1 - r_2)^2}$, r_1 and r_2 are the radii of the two ends of the frustum and h is the vertical height.
8. An open metallic bucket is in the shape of a frustum of a cone, mounted on a hollow cylindrical base made of the same metallic sheet. The surface area of the metallic sheet used is equal to
 curved surface area of frustum of a cone + area of circular base + curved surface area of cylinder

(C) Short Answer Questions

Sample Question 1 : A cone of maximum size is carved out from a cube of edge 14 cm. Find the surface area of the cone and of the remaining solid left out after the cone carved out.

Solution : The cone of maximum size that is carved out from a cube of edge 14 cm will be of base radius 7 cm and the height 14 cm.

Surface area of the cone = $\pi r l + \pi r^2$

$$= \frac{22}{7} \times 7 \times \sqrt{7^2 + 14^2} + \frac{22}{7} (7)^2$$

$$= \frac{22}{7} \times 7 \times \sqrt{245} + 154 = (154\sqrt{5} + 154) \text{ cm}^2 = 154(\sqrt{5} + 1) \text{ cm}^2$$

$$\text{Surface area of the cube} = 6 \times (14)^2 = 6 \times 196 = 1176 \text{ cm}^2$$

So, surface area of the remaining solid left out after the cone is carved out

$$= (1176 - 154 + 154\sqrt{5}) \text{ cm}^2 = (1022 + 154\sqrt{5}) \text{ cm}^2.$$

Sample Question 2 : A solid metallic sphere of radius 10.5 cm is melted and recast into a number of smaller cones, each of radius 3.5 cm and height 3 cm. Find the number of cones so formed.

Solution : The volume of the solid metallic sphere = $\frac{4}{3}\pi(10.5)^3 \text{ cm}^3$

Volume of a cone of radius 3.5 cm and height 3 cm = $\frac{1}{3}\pi(3.5)^2 \times 3 \text{ cm}^3$

$$\text{Number of cones so formed} = \frac{\frac{4}{3}\pi \times 10.5 \times 10.5 \times 10.5}{\frac{1}{3}\pi \times 3.5 \times 3.5 \times 3} = 126$$

Sample Question 3 : A canal is 300 cm wide and 120 cm deep. The water in the canal is flowing with a speed of 20 km/h. How much area will it irrigate in 20 minutes if 8 cm of standing water is desired?

Solution : Volume of water flows in the canal in one hour = width of the canal \times depth of the canal \times speed of the canal water = $3 \times 1.2 \times 20 \times 1000 \text{ m}^3 = 72000 \text{ m}^3$.

In 20 minutes the volume of water = $\frac{72000}{60} \times 20 \text{ m}^3 = 24000 \text{ m}^3$.

Area irrigated in 20 minutes, if 8 cm, i.e., 0.08 m standing water is required

$$\frac{24000}{0.08} \text{ m}^2 = 300000 \text{ m}^2 = 30 \text{ hectares.}$$

Sample Question 4 : A cone of radius 4 cm is divided into two parts by drawing a plane through the mid point of its axis and parallel to its base. Compare the volumes of the two parts.

Solution : Let h be the height of the given cone. On dividing the cone through the mid-point of its axis and parallel to its base into two parts, we obtain the following (see Fig. 12.8):

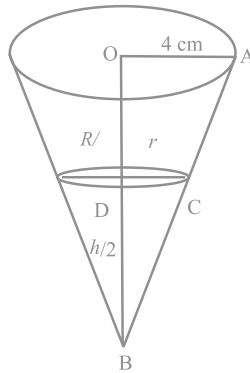

Fig. 12.8

In two similar triangles OAB and DCB, we have $\frac{OA}{CD} = \frac{OB}{BD}$. This implies $\frac{4}{r} = \frac{h}{\frac{h}{2}}$.

Therefore, $r = 2$.

$$\text{Therefore, } \frac{\text{Volume of the smaller cone}}{\text{Volume of the frustum of the cone}} = \frac{\frac{1}{3}\pi \times (2)^2 \times \left(\frac{h}{2}\right)}{\frac{1}{3}\pi \times \left(\frac{h}{2}\right) [4^2 + 2^2 + 4 \times 2]} = \frac{1}{7}$$

Therefore, the ratio of volume of the smaller cone to the volume of the frustum of the cone is 1: 7.

Sample Question 5 : Three cubes of a metal whose edges are in the ratio 3:4:5 are melted and converted into a single cube whose diagonal is $12\sqrt{3}$ cm. Find the edges of the three cubes.

Solution : Let the edges of three cubes (in cm) be $3x$, $4x$ and $5x$, respectively.

$$\text{Volume of the cubes after melting is } = (3x)^3 + (4x)^3 + (5x)^3 = 216x^3 \text{ cm}^3$$

Let a be the side of new cube so formed after melting. Therefore, $a^3 = 216x^3$

$$\text{So, } a = 6x, \text{ Diagonal} = \sqrt{a^2 + a^2 + a^2} = a\sqrt{3}$$

But it is given that diagonal of the new cube is $12\sqrt{3}$ cm. Therefore, $a\sqrt{3} = 12\sqrt{3}$, i.e., $a = 12$.

This gives $x = 2$. Therefore, edges of the three cubes are 6 cm, 8 cm and 10 cm, respectively.

EXERCISE 12.3

- Three metallic solid cubes whose edges are 3 cm, 4 cm and 5 cm are melted and formed into a single cube. Find the edge of the cube so formed.
- How many shots each having diameter 3 cm can be made from a cuboidal lead solid of dimensions $9\text{cm} \times 11\text{cm} \times 12\text{cm}$?
- A bucket is in the form of a frustum of a cone and holds 28.490 litres of water. The radii of the top and bottom are 28 cm and 21 cm, respectively. Find the height of the bucket.
- A cone of radius 8 cm and height 12 cm is divided into two parts by a plane through the mid-point of its axis parallel to its base. Find the ratio of the volumes of two parts.
- Two identical cubes each of volume 64 cm^3 are joined together end to end. What is the surface area of the resulting cuboid?
- From a solid cube of side 7 cm, a conical cavity of height 7 cm and radius 3 cm is hollowed out. Find the volume of the remaining solid.
- Two cones with same base radius 8 cm and height 15 cm are joined together along their bases. Find the surface area of the shape so formed.
- Two solid cones A and B are placed in a cylindrical tube as shown in the Fig. 12.9. The ratio of their capacities are 2:1. Find the heights and capacities of cones. Also, find the volume of the remaining portion of the cylinder.

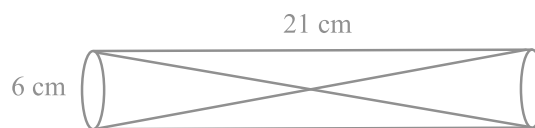

Fig. 12.9

- An ice cream cone full of ice cream having radius 5 cm and height 10 cm as shown in the Fig. 12.10. Calculate the volume of ice cream, provided that its $\frac{1}{6}$ part is left unfilled with ice cream.

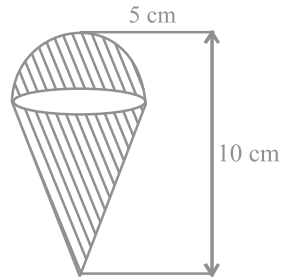

Fig. 12.10

10. Marbles of diameter 1.4 cm are dropped into a cylindrical beaker of diameter 7 cm containing some water. Find the number of marbles that should be dropped into the beaker so that the water level rises by 5.6 cm.
11. How many spherical lead shots each of diameter 4.2 cm can be obtained from a solid rectangular lead piece with dimensions 66 cm, 42 cm and 21 cm.
12. How many spherical lead shots of diameter 4 cm can be made out of a solid cube of lead whose edge measures 44 cm.
13. A wall 24 m long, 0.4 m thick and 6 m high is constructed with the bricks each of dimensions 25 cm \times 16 cm \times 10 cm. If the mortar occupies $\frac{1}{10}$ th of the volume of the wall, then find the number of bricks used in constructing the wall.
14. Find the number of metallic circular disc with 1.5 cm base diameter and of height 0.2 cm to be melted to form a right circular cylinder of height 10 cm and diameter 4.5 cm.

(E) Long Answer Questions

Sample Question 1 : A bucket is in the form of a frustum of a cone of height 30 cm with radii of its lower and upper ends as 10 cm and 20 cm, respectively. Find the capacity and surface area of the bucket. Also, find the cost of milk which can completely fill the container, at the rate of Rs 25 per litre (use $\pi = 3.14$).

Solution : Capacity (or volume) of the bucket = $\frac{\pi h}{3} [r_1^2 + r_2^2 + r_1 r_2]$.

Here, $h = 30$ cm, $r_1 = 20$ cm and $r_2 = 10$ cm.

So, the capacity of bucket = $\frac{3.14 \times 30}{3} [20^2 - 10^2 + 20 \times 10] \text{ cm}^3 = 21.980 \text{ litres.}$

Cost of 1 litre of milk = Rs 25

Cost of 21.980 litres of milk = Rs $21.980 \times 25 = \text{Rs } 549.50$

Surface area of the bucket = curved surface area of the bucket
+ surface area of the bottom

$$= \pi l (r_1 + r_2) + \pi r_2^2, \quad l = \sqrt{h^2 + (r_1 - r_2)^2}$$

Now, $l = \sqrt{900 + 100} \text{ cm} = 31.62 \text{ cm}$

Therefore, surface area of the bucket = $3.14 \times 31.62(20 + 10) + \frac{22}{7}(10)^2$
 $= 3.14 [948.6 + 100] \text{ cm}^2$
 $= 3.14 [1048.6] \text{ cm}^2 = 3292.6 \text{ cm}^2 \text{ (approx.)}$

Sample Question 2 : A solid toy is in the form of a hemisphere surmounted by a right circular cone. The height of the cone is 4 cm and the diameter of the base is 8 cm. Determine the volume of the toy. If a cube circumscribes the toy, then find the difference of the volumes of cube and the toy. Also, find the total surface area of the toy.

Solution : Let r be the radius of the hemisphere and the cone and h be the height of the cone (see Fig. 12.11).

Volume of the toy = Volume of the hemisphere + Volume of the cone

$$= \frac{2}{3}\pi r^3 + \frac{1}{3}\pi r^2 h$$

$$= \left(\frac{2}{3} \times \frac{22}{7} \times 4^3 + \frac{1}{3} \times \frac{22}{7} \times 4^2 \times 4 \right) \text{ cm}^3 = \frac{1408}{7} \text{ cm}^3.$$

A cube circumscribes the given solid. Therefore, edge of the cube should be 8 cm.

Volume of the cube = $8^3 \text{ cm}^3 = 512 \text{ cm}^3.$

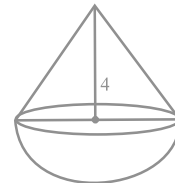

Fig. 12.11

$$\text{Difference in the volumes of the cube and the toy} = \left(512 - \frac{1408}{7} \right) \text{cm}^3 = 310.86 \text{ cm}^3$$

Total surface area of the toy = Curved surface area of cone
+ curved surface area of hemisphere

$$= \pi r l + 2\pi r^2, \text{ where } l = \sqrt{h^2 + r^2}$$

$$= \pi r (l + 2r)$$

$$= \frac{22}{7} \times 4 \times \sqrt{4^2 + 4^2} + 2 \times 4 \times 4 \text{ cm}^2$$

$$= \frac{22}{7} \times 4 \times 4\sqrt{2} + 8 \text{ cm}^2$$

$$= \frac{88}{7} \times 4\sqrt{2} + 8 \text{ cm}^2$$

$$= 171.68 \text{ cm}^2$$

Sample Question 3 : A building is in the form of a cylinder surmounted by a hemispherical dome (see Fig. 12.12). The

base diameter of the dome is equal to $\frac{2}{3}$ of the total height of the building. Find the height of the building, if it contains

$67\frac{1}{21}$ m³ of air.

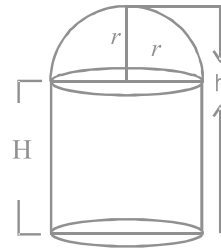

Fig. 12.12

Solution : Let the radius of the hemispherical dome be r metres and the total height of the building be h metres.

Since the base diameter of the dome is equal to $\frac{2}{3}$ of the total height, therefore

$2r = \frac{2}{3}h$. This implies $r = \frac{h}{3}$. Let H metres be the height of the cylindrical portion.

Therefore, $H = h - \frac{h}{3} = \frac{2}{3}h$ metres.

Volume of the air inside the building = Volume of air inside the dome + Volume of the air inside the cylinder = $\frac{2}{3}\pi r^3 + \pi r^2 H$, where H is the height of the cylindrical portion

$$\frac{2}{3}\pi \left(\frac{h}{3}\right)^3 + \pi \left(\frac{h}{3}\right)^2 \frac{2}{3}h = \frac{8}{81}\pi h^3 \text{ cu. metres}$$

Volume of the air inside the building is $67\frac{1}{21}\text{ m}^3$. Therefore, $\frac{8}{81}\pi h^3 = \frac{1408}{21}$. This gives $h = 6$ m.

EXERCISE 12.4

1. A solid metallic hemisphere of radius 8 cm is melted and recasted into a right circular cone of base radius 6 cm. Determine the height of the cone.
2. A rectangular water tank of base 11 m \times 6 m contains water upto a height of 5 m. If the water in the tank is transferred to a cylindrical tank of radius 3.5 m, find the height of the water level in the tank.
3. How many cubic centimetres of iron is required to construct an open box whose external dimensions are 36 cm, 25 cm and 16.5 cm provided the thickness of the iron is 1.5 cm. If one cubic cm of iron weighs 7.5 g, find the weight of the box.
4. The barrel of a fountain pen, cylindrical in shape, is 7 cm long and 5 mm in diameter. A full barrel of ink in the pen is used up on writing 3300 words on an average. How many words can be written in a bottle of ink containing one fifth of a litre?
5. Water flows at the rate of 10m/minute through a cylindrical pipe 5 mm in diameter. How long would it take to fill a conical vessel whose diameter at the base is 40 cm and depth 24 cm?
6. A heap of rice is in the form of a cone of diameter 9 m and height 3.5 m. Find the volume of the rice. How much canvas cloth is required to just cover the heap?
7. A factory manufactures 120000 pencils daily. The pencils are cylindrical in shape each of length 25 cm and circumference of base as 1.5 cm. Determine the cost of colouring the curved surfaces of the pencils manufactured in one day at Rs 0.05 per dm^2 .

8. Water is flowing at the rate of 15 km/h through a pipe of diameter 14 cm into a cuboidal pond which is 50 m long and 44 m wide. In what time will the level of water in pond rise by 21 cm?
9. A solid iron cuboidal block of dimensions $4.4 \text{ m} \times 2.6 \text{ m} \times 1 \text{ m}$ is recast into a hollow cylindrical pipe of internal radius 30 cm and thickness 5 cm. Find the length of the pipe.
10. 500 persons are taking a dip into a cuboidal pond which is 80 m long and 50 m broad. What is the rise of water level in the pond, if the average displacement of the water by a person is 0.04 m^3 ?
11. 16 glass spheres each of radius 2 cm are packed into a cuboidal box of internal dimensions $16 \text{ cm} \times 8 \text{ cm} \times 8 \text{ cm}$ and then the box is filled with water. Find the volume of water filled in the box.
12. A milk container of height 16 cm is made of metal sheet in the form of a frustum of a cone with radii of its lower and upper ends as 8 cm and 20 cm respectively. Find the cost of milk at the rate of Rs. 22 per litre which the container can hold.
13. A cylindrical bucket of height 32 cm and base radius 18 cm is filled with sand. This bucket is emptied on the ground and a conical heap of sand is formed. If the height of the conical heap is 24 cm, find the radius and slant height of the heap.
14. A rocket is in the form of a right circular cylinder closed at the lower end and surmounted by a cone with the same radius as that of the cylinder. The diameter and height of the cylinder are 6 cm and 12 cm, respectively. If the slant height of the conical portion is 5 cm, find the total surface area and volume of the rocket [Use $\pi = 3.14$].
15. A building is in the form of a cylinder surmounted by a hemispherical vaulted dome and contains $41\frac{19}{21} \text{ m}^3$ of air. If the internal diameter of dome is equal to its total height above the floor, find the height of the building?
16. A hemispherical bowl of internal radius 9 cm is full of liquid. The liquid is to be filled into cylindrical shaped bottles each of radius 1.5 cm and height 4 cm. How many bottles are needed to empty the bowl?
17. A solid right circular cone of height 120 cm and radius 60 cm is placed in a right circular cylinder full of water of height 180 cm such that it touches the bottom. Find the volume of water left in the cylinder, if the radius of the cylinder is equal to the radius of the cone.

- 18.** Water flows through a cylindrical pipe, whose inner radius is 1 cm, at the rate of 80 cm/sec in an empty cylindrical tank, the radius of whose base is 40 cm. What is the rise of water level in tank in half an hour?
- 19.** The rain water from a roof of dimensions 22 m \times 20 m drains into a cylindrical vessel having diameter of base 2 m and height 3.5 m. If the rain water collected from the roof just fill the cylindrical vessel, then find the rainfall in cm.
- 20.** A pen stand made of wood is in the shape of a cuboid with four conical depressions and a cubical depression to hold the pens and pins, respectively. The dimension of the cuboid are 10 cm, 5 cm and 4 cm. The radius of each of the conical depressions is 0.5 cm and the depth is 2.1 cm. The edge of the cubical depression is 3 cm. Find the volume of the wood in the entire stand.

DESIGN OF THE QUESTION PAPER
Mathematics
Class X

Time : 3 Hours

Maximum Marks : 80

Weightage and the distribution of marks over different dimensions of the question shall be as follows:

(A) Weightage to Content/ Subject Units :

S.No.	Content Unit	Marks
1.	Number Systems	04
2.	Algebra	20
3.	Trigonometry	12
4.	Coordinate Geometry	08
5.	Geometry	16
6.	Mensuration	10
7.	Statistics and Probability	10
Total : 80		

(B) Weightage to Forms of Questions :

S.No.	Form of Questions	Marks for each Question	Number of Questions	Total Marks
1.	MCQ	01	10	10
2.	SAR	02	05	10
3.	SA	03	10	30
4.	LA	06	05	30
Total			30	80

(C) Scheme of Options

All questions are compulsory, i.e., there is no overall choice. However, internal choices are provided in one question of 2 marks, three questions of 3 marks each and two questions of 6 marks each.

(D) Weightage to Difficulty Level of Questions

S.No.	Estimated Difficulty Level of Questions	Percentage of Marks
1.	Easy	20
2.	Average	60
3.	Difficult	20

Note : A question may vary in difficulty level from individual to individual. As such, the assessment in respect of each will be made by the paper setter/ teacher on the basis of general anticipation from the groups as whole taking the examination. This provision is only to make the paper balanced in its weight, rather to determine the pattern of marking at any stage.

**BLUE PRINT
MATHEMATICS
CLASS X**

Form of Question					
Units	MCQ	SAR	SA	LA	Total
Number Systems	2(2)	2(1)	-	-	4(3)
Algebra Polynomials, Pair of Linear Equations in Two Variables, Quadratic Equations, Arithmetic Progressions	3(3)	2(1)	9(3)	6(1)	20(8)
Trigonometry Introduction to Trigonometry, Some Applications of Trigonometry	1(1)	2(1)	3(1)	6(1)	12(4)
Coordinate Geometry	1(1)	4(2)	3(1)	-	8(4)
Geometry Triangles, Circles, Constructions	1(1)	-	9(3)	6(1)	16(5)
Mensuration Areas related to Circles, Surface Areas and Volumes	1(1)	-	3(1)	6(1)	10(3)
Statistics & Probability	1(1)	-	3(1)	6(1)	10(3)
Total	10(10)	10(5)	30(10)	30(5)	80(30)

SUMMARY

Multiple Choice Questions (MCQ)	Number of Questions : 10	Marks : 10
Short Answer Questions with Resasoning (SAR)	Number of Questions : 05	Marks : 10
Short Answer Questions (SA)	Number of Questions : 10	Marks : 30
Long Answer Questions (LA)	Number of Questions : 05	Marks : 30
Total	30	80

Mathematics
Class X

Maximum Marks : 80

Time : 3 Hours

General Instructions

- All questions are compulsory.
- The question paper consists of 30 questions divided into four sections A, B, C, and D. Section A contains 10 questions of 1 mark each, Section B contains 5 questions of 2 marks each, Section C contains 10 questions of 3 marks each and Section D contains 5 questions of 6 marks each.
- There is no overall choice. However, an internal choice has been provided in one question of 2 marks, three questions of 3 marks and two questions of 6 marks each.
- In questions on construction, the drawing should be neat and exactly as per given measurements.
- Use of calculators is not allowed.

SECTION A

- After how many decimal places will the decimal expansion of the number $\frac{47}{2^3 5^2}$ terminate?
(A) 5 (B) 2 (C) 3 (D) 1
- Euclid's division lemma states that for two positive integers a and b , there exist unique integers q and r such that $a = bq + r$, where
(A) $0 \leq r \leq a$ (B) $0 < r < b$ (C) $0 \leq r \leq b$ (D) $0 \leq r < b$
- The number of zeroes, the polynomial $p(x) = (x - 2)^2 + 4$ can have, is
(A) 1 (B) 2 (C) 0 (D) 3
- A pair of linear equations $a_1x + b_1y + c_1 = 0$; $a_2x + b_2y + c_2 = 0$ is said to be inconsistent, if
(A) $\frac{a_1}{a_2} \neq \frac{b_1}{b_2}$ (B) $\frac{a_1}{a_2} \neq \frac{b_1}{b_2} = \frac{c_1}{c_2}$ (C) $\frac{a_1}{a_2} = \frac{b_1}{b_2} \neq \frac{c_1}{c_2}$ (D) $\frac{a_1}{a_2} \neq \frac{c_1}{c_2}$
- The smallest value of k for which the equation $x^2 + kx + 9 = 0$ has real roots, is
(A) -6 (B) 6 (C) 36 (D) -3
- The coordinates of the points P and Q are $(4, -3)$ and $(-1, 7)$. Then the abscissa of a point R on the line segment PQ such that $\frac{PR}{PQ} = \frac{3}{5}$ is

- (A) $\frac{18}{5}$ (B) $\frac{17}{5}$ (C) $\frac{17}{8}$ (D) 1

7. In the adjoining figure, PA and PB are tangents from a point P to a circle with centre O. Then the quadrilateral OAPB must be a

- (A) square (B) rhombus
(C) cyclic quadrilateral (D) parallelogram

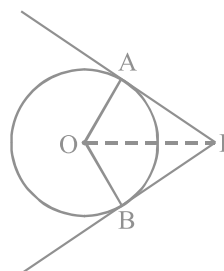

8. If for some angle θ , $\cot 2\theta = \frac{1}{\sqrt{3}}$, then the value of $\sin 3\theta$, where $2\theta \leq 90^\circ$ is

- (A) $\frac{1}{\sqrt{2}}$ (B) 1 (C) 0 (D) $\frac{\sqrt{3}}{2}$

9. From each corner of a square of side 4 cm, a quadrant of a circle of radius 1 cm is cut and also a circle of diameter 2 cm is cut as shown in figure. The area of the remaining (shaded) portion is

- (A) $(16 - 2\pi)$ cm² (B) $(16 - 5\pi)$ cm²
(C) 2π cm² (D) 5π cm²

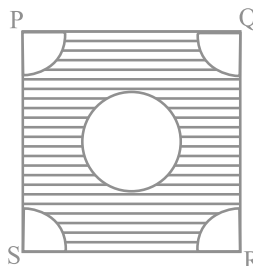

10. A letter of English alphabets is chosen at random. The probability that it is a letter of the word 'MATHEMATICS' is

- (A) $\frac{11}{26}$ (B) $\frac{5}{13}$ (C) $\frac{9}{26}$ (D) $\frac{4}{13}$

SECTION B

11. Is there any natural number n for which 4^n ends with the digit 0? Give reasons in support of your answer.
12. Without using the formula for the n^{th} term, find which term of the AP : 5, 17, 29, 41, ... will be 120 more than its 15th term? Justify your answer.

OR

Is 144 a term of the AP : 3, 7, 11, ... ? Justify your answer.

13. The coordinates of the points P, Q and R are (3, 4), (3, -4) and (-3, 4), respectively. Is the area of ΔPQR 24 sq. units? Justify your answer.

14. The length of a line segment is 10 units. If one end is $(2, -3)$ and the abscissa of the other end is 10, then its ordinate is either 3 or -9 . Give justification for the two answers.
15. What is the maximum value of $\frac{3}{\operatorname{cosec}}$? Justify your answer.

SECTION C

16. Find the zeroes of the polynomial $p(x) = 4\sqrt{3}x^2 - 2\sqrt{3}x - 2\sqrt{3}$ and verify the relationship between the zeroes and the coefficients.

OR

On dividing the polynomial $f(x) = x^3 - 5x^2 + 6x - 4$ by a polynomial $g(x)$, the quotient $q(x)$ and remainder $r(x)$ are $x - 3, -3x + 5$, respectively. Find the polynomial $g(x)$.

17. Solve the equations $5x - y = 5$ and $3x - y = 3$ graphically.
18. If the sum of the first n terms of an AP is $4n - n^2$, what is the 10^{th} term and the n^{th} term?

OR

How many terms of the AP : 9, 17, 25, ... must be taken to give a sum 636?

19. If $(1, 2), (4, y), (x, 6)$ and $(3, 5)$ are the vertices of a parallelogram taken in order, find the values of x and y .
20. The sides AB, BC and median AD of a ΔABC are respectively proportional to the sides PQ, QR and the median PM of ΔPQR . Show that $\Delta ABC \sim \Delta PQR$.
21. A triangle ABC is drawn to circumscribe a circle of radius 4 cm such that the segments BD and DC into which BC is divided by the point of contact D are of lengths 8 cm and 7 cm, respectively. Find the sides AB and AC.
22. Construct an isosceles triangle whose base is 6 cm and altitude 5 cm and then another triangle whose sides are $\frac{7}{5}$ of the corresponding sides of the isosceles triangle.

23. Prove that $\frac{\cos -\sin}{\sin \cos} \frac{1}{-1} = \frac{1}{\operatorname{cosec} -\cot}$.

OR

Evaluate:

$$\frac{3 \cos 43}{\sin 47}^2 - \frac{\cos 37 \operatorname{cosec} 53}{\tan 5 \tan 25 \tan 45 \tan 65 \tan 85}$$

24. In the figure, ABC is a triangle right angled at A. Semicircles are drawn on AB, AC and BC as diameters. Find the area of the shaded region.

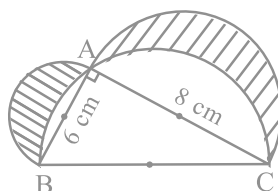

25. A bag contains white, black and red balls only. A ball is drawn at random from the bag. The probability of getting a white ball is $\frac{3}{10}$ and that of a black ball is $\frac{2}{5}$. Find the probability of getting a red ball. If the bag contains 20 black balls, then find the total number of balls in the bag.

SECTION D

26. If the price of a book is reduced by Rs 5, a person can buy 5 more books for Rs 300. Find the original list price of the book.

OR

The sum of the ages of two friends is 20 years. Four years ago, the product of their ages in years was 48. Is this situation possible? If so, determine their present ages.

27. Prove that the lengths of the tangents drawn from an external point to a circle are equal.

Using the above theorem, prove that:

If quadrilateral ABCD is circumscribing a circle, then $AB + CD = AD + BC$.

OR

Prove that the ratio of the areas of two similar triangles is equal to the ratio of the squares of the corresponding sides.

Using the above theorem, do the following :

ABC is an isosceles triangle right angled at B. Two equilateral triangles ACD and ABE are constructed on the sides AC and AB, respectively. Find the ratio of the areas of ΔABE and ΔACD .

28. The angles of depression of the top and bottom of a building 50 metres high as observed from the top of a tower are 30° and 60° , respectively. Find the height of the tower and also the horizontal distances between the building and the tower.
29. A well of diameter 3 m and 14 m deep is dug. The earth, taken out of it, has been evenly spread all around it in the shape of a circular ring of width 4 m to form an embankment . Find the height of the embankment.
30. The following table shows the ages of the patients admitted in a hospital during a month:

Age (in years) :	5 - 15	15 - 25	25 - 35	35 - 45	45 - 55	55 - 65
Number of patients :	6	11	21	23	14	5

Find the mode and the mean of the data given above.

MARKING SCHEME**SECTION A**

					MARKS
1. (C)	2. (D)	3. (C)	4. (C)	5. (A)	6. (D)
7. (C)	8. (B)	9. (A)	10. (D)		(1 × 10 = 10)

SECTION B

11. No	$(\frac{1}{2})$
$4^n = 2^{2n}$	
Therefore, 2 is the only prime number in its prime factorisation, so it cannot end with zero.	$(1\frac{1}{2})$
12. 25th term	$(\frac{1}{2})$
120 will be added in 10 terms (since $d = 12$)	
Therefore, $15 + 10 = 25$	$(1\frac{1}{2})$
OR	
No	$(\frac{1}{2})$
Here, $a = 3$ (odd), $d = 4$ (even)	
Sum of (odd + even) = odd but 144 is even	$(1\frac{1}{2})$
13. Yes	$(\frac{1}{2})$
Here, $PQ = 8$,	
$PR = 6$, therefore, area = $\frac{1}{2} \cdot 8 \cdot 6 = 24$ sq. units.	$(1\frac{1}{2})$
14. Let ordinate of the point be y. Then $(10 - 2)^2 + (y + 3)^2 = 10^2$, i.e., $y + 3 = \pm 6$,	
i.e., $y = 3$ or -9	$(1 + 1)$
15. Maximum value = 3	$(\frac{1}{2})$

$$\text{Since } \frac{3}{\operatorname{cosec} \theta} = 3 \sin \theta, \text{ and } \sin \theta \leq 1, \text{ therefore, } 3 \sin \theta \leq 3 \quad \left(1\frac{1}{2}\right)$$

SECTION C

$$\begin{aligned} 16. \quad p(x) &= 4\sqrt{3}x^2 - 2\sqrt{3}x - 2\sqrt{3} = 2\sqrt{3}(2x^2 - x - 1) \\ &= 2\sqrt{3}(2x + 1)(x - 1) \end{aligned}$$

$$\text{Therefore, two zeroes are } -\frac{1}{2}, 1 \quad (1)$$

$$\text{Here } a = 4\sqrt{3}, b = 2\sqrt{3}, c = -2\sqrt{3}$$

$$\text{Therefore, } \alpha + \beta = -\frac{1}{2} + 1 = \frac{1}{2}, \quad -\frac{b}{a} = \frac{2\sqrt{3}}{4\sqrt{3}} = \frac{1}{2}, \text{ i.e., } \alpha + \beta = -\frac{b}{a} \quad (1)$$

$$\alpha\beta = \left(-\frac{1}{2}\right)1 = -\frac{1}{2}, \quad \frac{c}{a} = \frac{-2\sqrt{3}}{4\sqrt{3}} = -\frac{1}{2}, \text{ i.e., } \alpha\beta = \frac{c}{a} \quad (1)$$

OR

$$f(x) = g(x)q(x) + r(x)$$

$$\text{Therefore, } x^3 - 5x^2 + 6x - 4 = g(x)(x - 3) + (-3x + 5) \quad (1)$$

$$\text{Therefore, } g(x) = \frac{x^3 - 5x^2 + 6x - 4 + 3x - 5}{x - 3} = \frac{x^3 - 5x^2 + 9x - 4}{x - 3} \quad (1)$$

$$= x^2 - 2x + 3 \quad (1)$$

$$17. \quad 5x - y = 5 \qquad 3x - y = 3$$

x	1	2	3
y	0	5	10

x	1	2	3
y	0	3	6

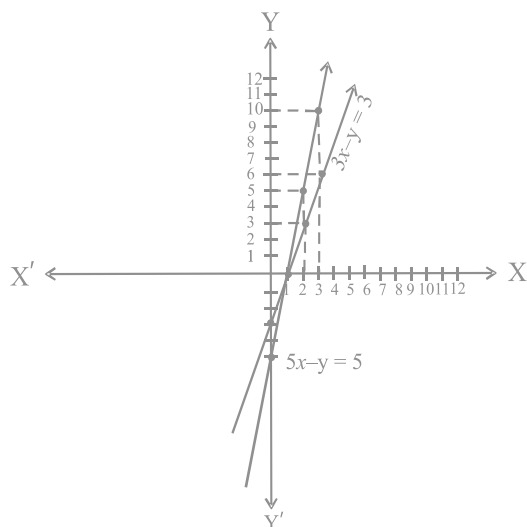

For correct graph (2)

Solution is $x = 1, y = 0$ (1)

18. $S_n = 4n - n^2$. Therefore, $t_{10} = S_{10} - S_9 = (40 - 100) - (36 - 81)$ ($\frac{1}{2}$)

$= -60 + 45 = -15$ (1)

$t_n = S_n - S_{n-1} = (4n - n^2) - [4(n-1) - (n-1)^2]$ ($\frac{1}{2}$)

$= 4n - n^2 - 4n + 4 + n^2 + 1 - 2n = 5 - 2n$ (1)

OR

$a = 9, d = 8, S_n = 636$ }

Using $S_n = \frac{n}{2} [2a + (n-1)d]$, we have $636 = \frac{n}{2} [18 + (n-1)8]$ ($1\frac{1}{2}$)

Solving to get $n = 12$ (1 $\frac{1}{2}$)

19. Let A (1, 2), B (4, y) and C (x, 6) and D (3, 5) be the vertices.

The mid-point of AC is $\left(\frac{x+1}{2}, 4\right)$ (1 $\frac{1}{2}$)

and mid-point of BD is $\left(\frac{7}{2}, \frac{y+5}{2}\right)$ (1 $\frac{1}{2}$)

ABCD is a parallelogram. Therefore, $\frac{x+1}{2} = \frac{7}{2}$, i.e., $x = 6$ (1)

$\frac{y+5}{2} = 4$, i.e., $y = 3$ (1)

20.

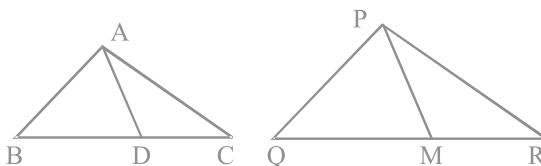

$$\text{Given } \frac{AB}{PQ} = \frac{BC}{QR} = \frac{BD}{QM} = \frac{AD}{PM}$$

Therefore, $\Delta ABD \sim \Delta PQM$

[SSS] (1 $\frac{1}{2}$)

Therefore, $\angle B = \angle Q$. Also, since $\frac{AB}{PQ} = \frac{BC}{QR}$, i.e.,

$\Delta ABC \sim \Delta PQR$ [SAS] (1 $\frac{1}{2}$)

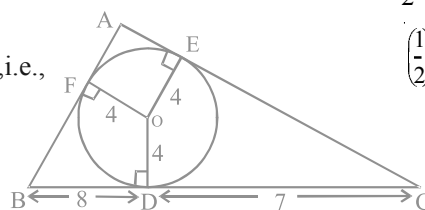

21. Let $AE (=AF) = x$ cm.

$$\text{Area } \Delta ABC = \frac{1}{2} \cdot 4 \cdot (AB + BC + AC)$$

$$= \sqrt{s(s-a)(s-b)(s-c)}$$

$$\text{i.e., } 4s = \sqrt{s(s-a)(s-b)(s-c)} \quad \left(\frac{1}{2}\right)$$

$$16s = (s-a)(s-b)(s-c) \quad \left(\frac{1}{2}\right)$$

$$\text{i.e., } 16(15+x) = x \cdot 8 \cdot 7, \text{ i.e., } x = 6 \quad (1)$$

$$\text{Therefore, } AB = 14 \text{ cm and } AC = 13 \text{ cm} \quad \left(\frac{1}{2}\right)$$

22. Construction of isosceles Δ with base 6 cm and altitude 5 cm (1)

Construction of similar Δ with scale factor $\frac{7}{5}$ (2)

$$23. \text{ LHS} = \frac{\cos \theta - \sin \theta + 1}{\sin \theta + \cos \theta - 1} = \frac{\cot \theta - 1 + \operatorname{cosec} \theta}{1 + \cot \theta - \operatorname{cosec} \theta} \quad (1)$$

$$= \frac{\cot \theta - 1 + \operatorname{cosec} \theta}{1 - (\operatorname{cosec} \theta - \cot \theta)} = \frac{\operatorname{cosec} \theta + \cot \theta - 1}{(\operatorname{cosec}^2 \theta - \cot^2 \theta) - (\operatorname{cosec} \theta - \cot \theta)} \quad (1)$$

$$= \frac{\operatorname{cosec} \theta + \cot \theta - 1}{(\operatorname{cosec} \theta - \cot \theta)(\operatorname{cosec} \theta + \cot \theta - 1)} = \frac{1}{\operatorname{cosec} \theta - \cot \theta} \quad (1)$$

OR

$$\frac{3 \cos 43^\circ}{\sin 47^\circ} - \frac{\cos 37^\circ \operatorname{cosec} 53^\circ}{\tan 5^\circ \tan 25^\circ \tan 45^\circ \tan 65^\circ \tan 85^\circ}$$

$$= \left[\frac{3 \cos 43^\circ}{\cos 43^\circ} \right]^2 - \frac{\cos 37^\circ \cdot \sec 37^\circ}{\tan 5^\circ \tan 25^\circ (1) \cot 25^\circ \cot 5^\circ} \quad (2)$$

$$= (3)^2 - \frac{1}{1} = 9 - 1 = 8 \quad (1)$$

24.

$$\text{Required area} = \begin{cases} \text{area of semicircle with diameter } AB + \\ \text{area of semicircle with diameter } AC + \\ \text{area of right triangle } ABC - \\ \text{area of semicircle with diameter } BC \end{cases} \quad (1)$$

$$\text{Required area} = \frac{1}{2} \cdot (3)^2 + \frac{1}{2} \cdot (4)^2 + \frac{1}{2} \cdot 6 \cdot 8 - \frac{1}{2} \cdot (5)^2 \text{ sq. units} \quad (1)$$

$$= 24 + \frac{1}{2} \pi (9 + 16 - 25) = 24 \text{ sq. units} \quad (1)$$

$$25. \text{ P(Red ball)} = 1 - \{ \text{P(White ball)} + \text{P(Black ball)} \} \quad (1)$$

$$= 1 - \left\{ \frac{3}{10} + \frac{2}{5} \right\} = \frac{3}{10} \quad \left(\frac{1}{2} \right)$$

Let the total number of balls be y .

$$\text{Therefore, } \frac{20}{y} = \frac{2}{5}, \text{ i.e., } y = 50 \quad \left(1 \frac{1}{2} \right)$$

SECTION D

26. Let the list price of a book be Rs x

$$\text{Therefore, number of books, for Rs 300} = \frac{300}{x} \quad \left(\frac{1}{2} \right)$$

$$\text{No. of books, when price is } (x - 5) = \frac{300}{x - 5} \quad \left(\frac{1}{2} \right)$$

$$\text{Therefore, } \frac{300}{x - 5} - \frac{300}{x} = 5 \quad (2)$$

$$300(x - x + 5) = 5x(x - 5)$$

$$300 = x(x - 5), \text{ i.e., } x^2 - 5x - 300 = 0 \quad (1)$$

$$\text{i.e., } x = 20, x = -15 \text{ (rejected)} \quad (1)$$

$$\text{Therefore, list price of a book} = \text{Rs } 20 \quad (1)$$

OR

Let the present age of one of them be x years, so the age of the other = $(20 - x)$ years

$$\text{Therefore, 4 years ago, their ages were, } x - 4, 16 - x \text{ years} \quad (1)$$

$$\text{Therefore, } (x - 4)(16 - x) = 48 \quad \left(1 \frac{1}{2} \right)$$

i.e., $-x^2 + 16x + 4x - 64 - 48 = 0$

$x^2 - 20x + 112 = 0$ (1)

Here $B^2 - 4AC = \sqrt{(20)^2 - 4(112)} = \sqrt{-48}$ (1/2)

Thus, the equation has no real solution (1)

Hence, the given situation is not possible (1)

27. For correct, given, to prove, construction and figure
For correct proof

$$\left. \begin{array}{l} AP = AS \\ BP = BQ \\ DR = DS \\ CR = CQ \end{array} \right\} \begin{array}{l} \text{(tangents to a circle from external} \\ \text{point are equal)} \end{array}$$

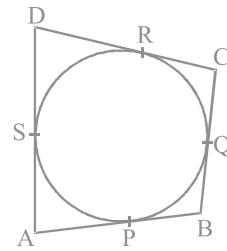

(1)

Adding to get $(AP + BP) + (DR + CR) = (AS + DS) + (BQ + CQ)$
i.e., $AB + CD = AD + BC$ (1)

OR

For correct, given, to prove, construction and figure (2)

For correct proof (2)

Let $AB = BC = a$, i.e., $AC = \sqrt{a^2 + a^2} = \sqrt{2}a$ (1/2)

$\frac{\text{area } \Delta ABC}{\text{area } \Delta ACD} = \frac{AB^2}{AC^2} = \frac{a^2}{2a^2} = \frac{1}{2}$ (1 1/2)

28. For correct figure

In ΔABD , $\frac{AB}{BD} = \tan 60^\circ = \sqrt{3}$

Therefore, $AB = \sqrt{3} BD$ (I)

In ΔACE , $\frac{AE}{EC} = \frac{AE}{BD} = \tan 30^\circ = \frac{1}{\sqrt{3}}$

i.e., $\frac{(AB - 50)}{BD} = \frac{1}{\sqrt{3}}$, i.e., $\sqrt{3} (AB - 50) = BD$ (1)

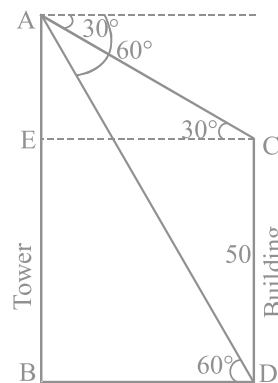

(1)

(1)

(1)

(1)

$$\text{Therefore, from (I) } AB = \sqrt{3} \cdot \sqrt{3} (AB - 50), \text{ i.e., } AB = 3AB - 150, \text{ i.e.,} \\ AB = 75 \text{ m} \quad (1)$$

$$BD = \sqrt{3} (75 - 50) = 25\sqrt{3} \text{ m} \quad (1)$$

$$29. \text{ Volume of earth dug out} = \pi r^2 h = \pi (1.5)^2 \times 14 = 31.5 \pi \text{ m}^3 \quad (2)$$

$$\text{Area of circular ring} = \pi[R^2 - r^2] = \pi[(5.5)^2 - (1.5)^2] \quad (1)$$

$$= \pi(7)(4) = 28\pi \text{ m}^2 \quad (1)$$

Let height of embankment be h metres

$$\text{Therefore, } 28\pi \times h = 31.5 \pi \quad (1)$$

$$h = \frac{31.5}{28} = 1.125 \text{ m} \quad (1)$$

30. Age (in years)	5-15	15-25	25-35	35- 45	45-55	55-65	Total
No. of patients(f_i)	6	11	21	23	14	5	80
Class marks(x_i)	10	20	30	40	50	60	($\frac{1}{2}$)
$f_i x_i$	60	220	630	920	700	300	2830 (1)

$$\text{Mean} = \frac{\sum f_i x_i}{\sum f_i} = \frac{2830}{80} = 35.375 \text{ years} \quad (1)$$

$$\text{Modal class is (35 - 45)} \quad (1)$$

$$\text{Therefore, Mode} = l + \frac{f_1 - f_0}{2f_1 - f_0 - f_2} \times h \quad (1)$$

$$\text{Putting } l = 35, f_1 = 23, f_0 = 21, f_2 = 14 \text{ and } h = 10, \text{ we get} \quad (1)$$

$$\text{Mode} = 35 + \frac{2}{11} \times 10 = 36.81 \text{ years} \quad (1)$$

Note: Full credit should be given for alternative correct solution.

DESIGN OF THE QUESTION PAPER
Mathematics
Class X

Time : 3 Hours

Maximum Marks : 80

Weightage and the distribution of marks over different dimensions of the question shall be as follows:

(A) Weightage to Content/ Subject Units :

S.No.	Content Unit	Marks
1.	Number Systems	04
2.	Algebra	20
3.	Trigonometry	12
4.	Coordinate Geometry	08
5.	Geometry	16
6.	Mensuration	10
7.	Statistics and Probability	10
Total : 80		

(B) Weightage to Forms of Questions :

S.No.	Form of Questions	Marks for each Question	Number of Questions	Total Marks
1.	MCQ	01	10	10
2.	SAR	02	05	10
3.	SA	03	10	30
4.	LA	06	05	30
Total			30	80

(C) Scheme of Options

All questions are compulsory, i.e., there is no overall choice. However, internal choices are provided in one question of 2 marks, three questions of 3 marks each and two questions of 6 marks each.

(D) Weightage to Difficulty level of Questions

S.No.	Estimated Difficulty Level of Questions	Percentage of Marks
1.	Easy	20
2.	Average	60
3.	Difficult	20

Note : A question may vary in difficulty level from individual to individual. As such, the assessment in respect of each will be made by the paper setter/ teacher on the basis of general anticipation from the groups as whole taking the examination. This provision is only to make the paper balanced in its weight, rather to determine the pattern of marking at any stage.

BLUE PRINT
MATHEMATICS
CLASS X

Form of Question Units ↓ →	MCQ	SAR	SA	LA	Total
Number Systems	2(2)	2(1)	-	-	4(3)
Algebra Polynomials, Pair of Linear Equations in Two Variables, Quadratic Equations, Arithmetic Progressions	3(3)	2(1)	9(3)	6(1)	20(8)
Trigonometry Introduction to Trigonometry, Some Applications of Trigonometry	1(1)	2(1)	3(1)	6(1)	12(4)
Coordinate Geometry	1(1)	4(2)	3(1)	-	8(4)
Geometry Triangles, Circles, Constructions	1(1)	-	9(3)	6(1)	16(5)
Mensuration Areas related to Circles, Surface Areas and Volumes	1(1)	-	3(1)	6(1)	10(3)
Statistics & Probability	1(1)	-	3(1)	6(1)	10(3)
Total	10(10)	10(5)	30(10)	30(5)	80(30)

SUMMARY

Multiple Choice Questions (MCQ)	Number of Questions : 10	Marks : 10
Short Answer Questions with Reasoning (SAR)	Number of Questions : 05	Marks : 10
Short Answer Questions (SA)	Number of Questions : 10	Marks : 30
Long Answer Questions (LA)	Number of Questions : 05	Marks : 30
Total	30	80

Mathematics
Class X

Maximum Marks : 80

Time : 3 Hours

General Instructions

1. All questions are compulsory.
2. The question paper consists of 30 questions divided into four sections A, B, C, and D. Section A contains 10 questions of 1 mark each, Section B contains 5 questions of 2 marks each, Section C contains 10 questions of 3 marks each and Section D contains 5 questions of 6 marks each.
3. There is no overall choice. However, an internal choice has been provided in one question of 2 marks, three questions of 3 marks and two questions of 6 marks each.
4. In questions on construction, the drawing should be neat and exactly as per given measurements.
5. Use of calculators is not allowed.

Section A

1. The largest number which divides 318 and 739 leaving remainders 3 and 4, respectively is
(A) 110 (B) 7 (C) 35 (D) 105
2. The number of zeroes lying between -2 to 2 of the polynomial $f(x)$, whose graph is given below, is
(A) 2 (B) 3 (C) 4 (D) 1

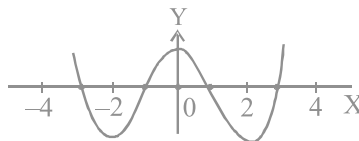

3. The discriminant of the quadratic equation $3\sqrt{3}x^2 + 10x + \sqrt{3} = 0$ is
(A) 8 (B) 64 (C) $-\frac{1}{3\sqrt{3}}$ (D) $-\sqrt{3}$

4. If $\frac{6}{5}$, a , 4 are in AP, the value of a is

- (A) 1 (B) 13 (C) $\frac{13}{5}$ (D) $\frac{26}{5}$

5. If in the following figure, $\Delta ABC \sim \Delta QPR$, then the measure of $\angle Q$ is
 (A) 60° (B) 90° (C) 70° (D) 50°

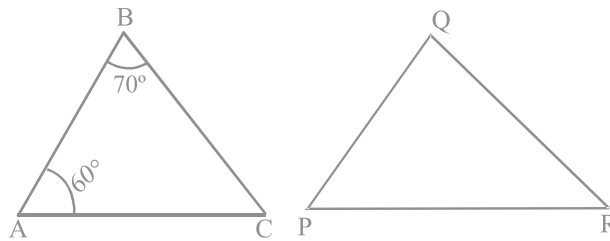

6. In the adjoining figure, ΔABC is circumscribing a circle. Then, the length of BC is
 (A) 7 cm (B) 8 cm (C) 9 cm (D) 10 cm

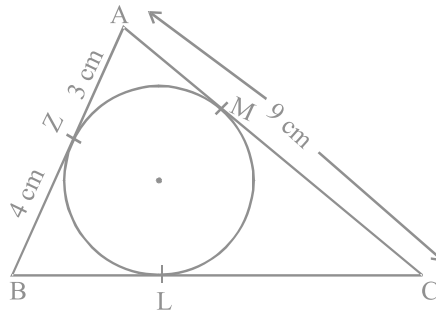

7. If $\sin \theta = \frac{1}{3}$, then the value of $(9 \cot^2 \theta + 9)$ is

- (A) 1 (B) 81 (C) 9 (D) $\frac{1}{81}$

8. The radii of the ends of a frustum of a cone 40 cm high are 20 cm and 11 cm. Its slant height is
 (A) 41 cm (B) $20\sqrt{5}$ cm (C) 49 cm (D) $\sqrt{521}$ cm
9. A bag contains 40 balls out of which some are red, some are blue and remaining are black. If the probability of drawing a red ball is $\frac{11}{20}$ and that of blue ball is $\frac{1}{5}$, then the number of black balls is
 (A) 5 (B) 25 (C) 10 (D) 30
10. Two coins are tossed simultaneously. The probability of getting at most one head is
 (A) $\frac{1}{4}$ (B) $\frac{1}{2}$ (C) $\frac{3}{4}$ (D) 1

SECTION B

11. Which of the following can be the n^{th} term of an AP?
 $3n + 1$, $2n^2 + 3$, $n^3 + n$.
 Give reasons.
12. Are the points $(-3, -3)$, $(-3, 2)$ and $(-3, 5)$ collinear? Give reasons.
13. ABC and BDE are two equilateral triangles such that D is the mid point of BC. What is the ratio of the areas of triangles ABC and BDE? Justify your answer.
14. $\cos(A + B) = \frac{1}{2}$ and $\sin(A - B) = \frac{1}{2}$, $0^\circ < A + B < 90^\circ$ and $A - B > 0^\circ$. What are the values of $\angle A$ and $\angle B$? Justify your answer.
15. A coin is tossed twice and the outcome is noted every time. Can you say that head must come once in two tosses? Justify your answer.

OR

A die is thrown once. The probability of getting a prime number is $\frac{2}{3}$. Is it true? Justify your answer.

SECTION C

16. Show that square of an odd positive integer is of the form $8q + 1$, for some positive integer q .

OR

Write the denominator of the rational number $\frac{357}{5000}$ in the form of $2^m 5^n$, m, n are non-negative integers and hence write its decimal expansion, without actual division.

17. If $(x - 2)$ is a factor of $x^3 + ax^2 + bx + 16$ and $b = 4a$, then find the values of a and b .
18. The sum of reciprocals of a child's age (in years) 3 years ago and 5 years from now is $\frac{1}{3}$. Find his present age.

OR

Solve for x : $6a^2x^2 - 7abx - 3b^2 = 0$, $a \neq 0$, using the quadratic formula.

19. Find the sum of all two digit natural numbers which are divisible by 7.
20. Find the ratio in which the line $x + 3y - 14 = 0$ divides the line segment joining the points A $(-2, 4)$ and B $(3, 7)$.
21. Find the area of the quadrilateral whose vertices in the same order are $(-4, -2)$, $(-3, -5)$, $(3, -2)$ and $(2, 3)$.
22. Two tangents PA and PB are drawn to a circle with centre O from an external point P. Prove that $\angle APB = 2\angle OAB$. (see the following figure).

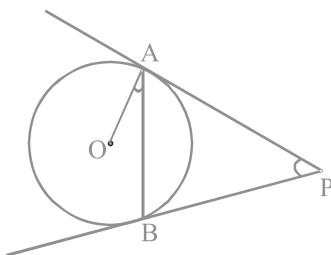

23. Construct a triangle with sides 3 cm, 5 cm and 7 cm and then construct another triangle whose sides are $\frac{5}{3}$ of the corresponding sides of the first triangle.

24. Prove the identity $(1 + \cot \theta + \tan \theta) (\sin \theta - \cos \theta) = \frac{\sec \theta}{\operatorname{cosec}^2 \theta} - \frac{\operatorname{cosec} \theta}{\sec^2 \theta}$

OR

Find the value of

$$\frac{\cos^2 32^\circ + \cos^2 58^\circ}{\sec^2 50^\circ - \cot^2 40^\circ} - 4 \tan 13^\circ \tan 37^\circ \tan 53^\circ \tan 77^\circ$$

25. The area of an equilateral triangle is $49\sqrt{3}$ cm². Taking each vertex as centre, circles are described with radius equal to half the length of the side of the triangle. Find the area of the part of the triangle not included in the circles. [Take

$$\sqrt{3} = 1.73, \pi = \frac{22}{7}]$$

SECTION D

26. In a bag containing white and red balls, half the number of white balls is equal to the one third the number of red balls. Twice the total number of balls exceeds three times the number of red balls by 8. How many balls of each type does the bag contain?

27. Prove that in a right triangle, the square of the hypotenuse is equal to sum of squares of the other two sides.

Using the above theorem, prove that in a triangle ABC, if AD is perpendicular to BC, then $AB^2 + CD^2 = AC^2 + BD^2$.

28. A pole 5m high is fixed on the top of a tower. The angle of elevation of the top of the pole as observed from a point A on the ground is 60° and the angle of depression of point A from the top of the tower is 45° . Find the height of the tower. (Take $\sqrt{3} = 1.73$)

29. The interior of a building is in the form of a cylinder of diameter 4 m and height 3.5 m, surmounted by a cone of the same base with vertical angle as a right angle. Find the surface area (curved) and volume of the interior of the building.

OR

A vessel in the form of an open inverted cone of height 8 cm and radius of its top is 5 cm. It is filled with water up to the brim. When lead shots, each of radius 0.5 cm are dropped into the vessel, one fourth of the water flows out. Find the number of lead shots dropped in the vessel.

30. Find the mean, median and mode of the following frequency distribution:

Class	0-10	10-20	20-30	30-40	40-50	50-60	60-70
Frequency	4	5	7	10	12	8	4

OR

The following distribution gives the daily income of 50 workers of a factory:

Daily income (in Rs)	100-120	120-140	140-160	160-180	180-200
Number of workers	12	14	8	6	10

Convert the distribution above to a less than type cumulative frequency distribution, and draw its ogive. Find the median from this ogive.

MARKING SCHEME**SECTION A**

				MARKS
1. (D)	2. (A)	3. (B)	4. (C)	5. (A)
6. (D)	7. (B)	8. (A)	9. (C)	10. (C)
				(1 × 10 = 10)

SECTION B

- 11.** n^{th} term is $3n + 1$, $\left(\frac{1}{2}\right)$
- because, n^{th} term of an AP can only be a linear relation in n . $\left(\frac{1}{2}\right)$
- 12.** Yes, $\left(\frac{1}{2}\right)$
- Since all the three points are on the line $x = -3$. $\left(\frac{1}{2}\right)$
- 13.** 4 : 1 $\left(\frac{1}{2}\right)$
- $$\frac{\text{ar ABC}}{\text{ar BDE}} = \frac{BC^2}{BD^2} = \frac{BC^2}{\left[\frac{1}{2}(BC)\right]^2} = \frac{4}{1}$$
- $\left(\frac{1}{2}\right)$
- 14.** $\angle A = 45^\circ$, $\angle B = 15^\circ$ $\left(\frac{1}{2}\right)$
- $A + B = 60^\circ$ and $A - B = 30^\circ$, solving, we get $\angle A = 45^\circ$, $\angle B = 15^\circ$ $\left(\frac{1}{2}\right)$
- 15.** No. $\left(\frac{1}{2}\right)$
- Head may come and head may not come. In every toss, there are two equally likely outcomes. $\left(\frac{1}{2}\right)$
- OR
- No. $\left(\frac{1}{2}\right)$
- $P(\text{a prime number}) = P(2, 3, 5) = \frac{3}{6} = \frac{1}{2}$ $\left(\frac{1}{2}\right)$

SECTION C

16. An odd positive integer can be of the form, $4n+1$ or $4n+3$ (1)

$$\text{Therefore, } (4n + 1)^2 = 16n^2 + 8n + 1 = 8(2n^2 + n) + 1 = 8q + 1. \quad (1)$$

$$(4n + 3)^2 = 16n^2 + 24n + 9 = 8(2n^2 + 3n + 1) + 1 = 8q + 1. \quad (1)$$

OR

$$\frac{357}{5000} = \frac{357}{2^3 \times 5^4} \quad (1)$$

$$= \frac{357 \times 2}{2^4 \times 5^4} = \frac{714}{(10)^4} \quad (1)$$

$$= 0.0714 \quad (1)$$

17. $(x-2)$ is a factor of $x^3 + ax^2 + bx + 16$

$$\text{Therefore, } (2)^3 + a(2)^2 + b(2) + 16 = 0 \quad (1)$$

$$4a + 2b + 24 = 0 \text{ or } 2a + b + 12 = 0 \quad (1)$$

$$\text{Given } b = 4a, \text{ so } a = -2 \quad (1)$$

$$\text{and } b = -8$$

18. Let the present age be x years. (1)

$$\text{Therefore, } \frac{1}{x-3} + \frac{1}{x+5} = \frac{1}{3}$$

$$\text{or } 3[(x+5) + (x-3)] = (x-3)(x+5)$$

$$\text{or } 6x + 6 = x^2 + 2x - 15.$$

$$\text{or } x^2 - 4x - 21 = 0$$

$$\text{or } (x-7)(x+3) = 0 \quad (1)$$

$$\text{i.e., } x = 7, x = -3 \text{ (rejected)}$$

$$\text{Therefore, present age} = 7 \text{ years} \quad (1)$$

OR

$$6a^2x^2 - 7abx - 3b^2 = 0$$

$$\begin{aligned} B^2 - 4AC &= [(-7ab)^2 - 4(6a^2)(-3b^2)] \\ &= 49a^2b^2 + 72a^2b^2 = 121a^2b^2 \end{aligned} \quad (1)$$

$$\text{Therefore, } x = \frac{-(-7ab) \pm 11ab}{12a^2} \quad (1)$$

$$\begin{aligned}
 &= \frac{18ab}{12a^2} \text{ or } \frac{-4ab}{12a^2} \\
 &= \frac{3b}{2a} \text{ or } -\frac{b}{3a} \quad (1)
 \end{aligned}$$

19. Numbers are

$$14, 21, \dots, 98 \quad (1)$$

$$98 = 14 + (n - 1) 7, \text{ i.e., } n = 13 \quad (1)$$

$$S_{13} = \frac{13}{2} [14 + 98] = 728. \quad (1)$$

20. Let C (x, y) be the point where the line $x + 3y - 14 = 0$ divides the line segment in the ratio $k:1$.

$$\text{So, } x = \frac{3k - 2}{k + 1}, y = \frac{7k + 4}{k + 1} \quad (1)$$

$$\text{and, } \frac{3k - 2}{k + 1} + 3 \cdot \frac{7k + 4}{k + 1} - 14 = 0 \quad \left(\frac{1}{2}\right)$$

$$\text{i.e., } 3k - 2 + 21k + 12 - 14k - 14 = 0,$$

$$\text{i.e., } 10k - 4 = 0$$

$$\text{i.e., } k = \frac{4}{10} = \frac{2}{5}$$

Therefore, ratio is 2 : 5

21. Area of ΔABC

$$= \frac{1}{2} [-4(-5 + 2) - 3(-2 + 2) + 3(-2 + 5)]$$

$$= \frac{1}{2} [12 + 9] = \frac{21}{2} \text{ sq. units} \quad (1)$$

$$\text{area of } \Delta ACD = \frac{1}{2} [-4(-2 - 3) + 3(3 + 2) + 2(-2 + 2)]$$

$$= \frac{1}{2} [20 + 15] = \frac{35}{2} \text{ sq. units} \quad (1)$$

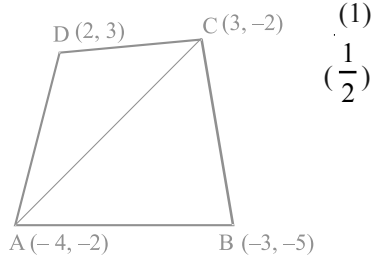

$$\text{Therefore, area of quadrilateral ABCD} = \frac{21+35}{2} = \frac{56}{2} = 28 \text{ sq. units} \quad (1)$$

$$\begin{aligned} 22. \text{ AP} = \text{PB. So, } \angle \text{PAB} = \angle \text{PBA} &= \frac{1}{2} [180^\circ - \angle \text{APB}] \\ &= 90^\circ - \frac{1}{2} \angle \text{APB} \end{aligned} \quad (1)$$

$$\angle \text{OAB} = 90^\circ - \angle \text{PAB} \quad (1)$$

$$= 90^\circ - [90^\circ - \frac{1}{2} \angle \text{APB}] = \frac{1}{2} \angle \text{APB}$$

$$\text{i.e., } 2 \angle \text{OAB} = \angle \text{APB} \quad (1)$$

23. Correct construction of Δ with sides 3, 5 and 7 cm (1)

Correct construction of similar triangle (2)

$$24. \text{ LHS} = \left(1 + \frac{\cos\theta}{\sin\theta} + \frac{\sin\theta}{\cos\theta}\right) (\sin\theta - \cos\theta) \quad \left(\frac{1}{2}\right)$$

$$= \frac{(\sin\theta \cos\theta + \cos^2\theta + \sin^2\theta) (\sin\theta - \cos\theta)}{\sin\theta \cos\theta} = \frac{\sin^3\theta - \cos^3\theta}{\sin\theta \cos\theta} \quad \left(1\frac{1}{2}\right)$$

$$= \frac{\sin^2\theta}{\cos\theta} - \frac{\cos^2\theta}{\sin\theta} = \frac{\sec\theta}{\text{cosec}^2\theta} - \frac{\text{cosec}\theta}{\sec^2\theta} \quad (1)$$

OR

$$\begin{aligned} \cos^2 58^\circ = \sin^2 32^\circ, \quad \tan 53^\circ = \cot 37^\circ \\ \sec^2 50^\circ = \text{cosec}^2 40^\circ, \quad \tan 77^\circ = \cot 13^\circ \end{aligned} \quad (2)$$

Given expression

$$\begin{aligned} &= \frac{\cos^2 32^\circ + \sin^2 32^\circ}{\text{cosec}^2 40^\circ - \cot^2 40^\circ} - 4 \tan 13^\circ \tan 37^\circ \cot 37^\circ \cot 13^\circ \\ &= 1 - 4 = -3 \end{aligned} \quad (1)$$

$$25. \text{ Area of } \Delta ABC = 49\sqrt{3} \text{ cm}^2 = \sqrt{3} \frac{a^2}{4}$$

$$\text{So, } a = 14 \text{ cm} \quad (1)$$

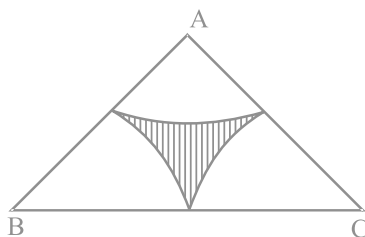

$$\text{Area of one sector} = \pi \times 7^2 \frac{60}{360} = \frac{49\pi}{6} \quad (1)$$

$$\begin{aligned} \text{Therefore, required area} &= 49\sqrt{3} - \frac{3 \times 49}{6} \times \left(\frac{22}{7}\right) \\ &= 49\sqrt{3} - 77 \\ &= 84.77 - 77 = 7.77 \text{ cm}^2 \end{aligned} \quad (1)$$

SECTION D

26. Let the number of white balls be x and number of red balls be y

$$\text{Therefore, } \frac{1}{2}x = \frac{1}{3}y, \text{ i.e., } 3x - 2y = 0 \quad (I) \quad \left(1 \frac{1}{2}\right)$$

$$\text{and } 2(x + y) = 3y + 8$$

$$\text{i.e., } 2x - y = 8 \quad (II) \quad \left(1 \frac{1}{2}\right)$$

$$\text{Solving (I) and (II), we get } x = 16, y = 24 \quad (2)$$

$$\text{Therefore, number of white balls} = 16$$

$$\text{Number of red balls} = 24 \quad (1)$$

$$27. \text{ For correct given, to prove, construction and proof} \quad \left(\frac{1}{2} \times 4 = 2\right)$$

$$\text{For correct proof} \quad (2)$$

$$AD^2 = AB^2 - BD^2$$

$(\frac{1}{2})$

$$\text{and } AD^2 = AC^2 - CD^2$$

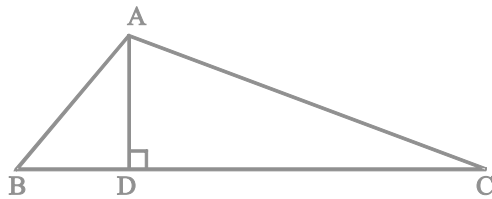

$(\frac{1}{2})$

$$\text{i.e., } AB^2 - BD^2 = AC^2 - CD^2$$

$(\frac{1}{2})$

$$\text{or } AB^2 + CD^2 = AC^2 + BD^2$$

$(\frac{1}{2})$

28. For correct figure

(1)

Let height of tower be h metres and $AB = x$ metres.

$(\frac{1}{2})$

$$\text{Therefore, } \frac{x}{h} = \cot 45^\circ = 1$$

(1)

$$\text{i.e., } x = h.$$

$(\frac{1}{2})$

$$\text{Also, } \frac{h+5}{x} = \tan 60^\circ = \sqrt{3}$$

(1)

$$\text{i.e., } h + 5 = \sqrt{3}x = \sqrt{3}h$$

$(\frac{1}{2})$

$$\text{i.e., } (\sqrt{3} - 1)h = 5$$

$$h = \frac{5}{\sqrt{3} - 1} \cdot \frac{\sqrt{3} + 1}{\sqrt{3} + 1}$$

$(\frac{1}{2})$

$$= \frac{5(\sqrt{3} + 1)}{2} = \frac{5(2.73)}{2}$$

$$= \frac{13.65}{2} = 6.825 \text{ m}$$

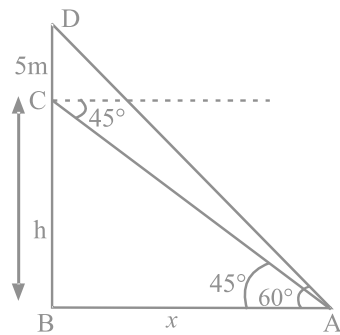

(1)

29. For correct figure

$(\frac{1}{2})$

Here, $\angle Q = 45^\circ$, i.e., height of cone = radius = 2m (1)

$$\begin{aligned} \text{Therefore, surface area} &= \pi r l + 2\pi r h \\ &= \pi r (l + 2h) \end{aligned} \quad (1)$$

$$= \pi \times 2 \times (2\sqrt{2} + 7)$$

$(\frac{1}{2})$

$$= (14 + 4\sqrt{2}) \pi \text{ m}^2$$

(1)

$$\text{Volume} = \frac{1}{3} \pi r^2 h_1 + \pi r^2 h \quad (\frac{1}{2})$$

$$= \pi r^2 \left[\frac{h_1}{3} + h \right]$$

$$= \pi \times 4 \times \frac{2}{3} \times 3.5 + 4\pi \times \frac{2}{3} \times 10.5$$

$$= \frac{50\pi}{3} \text{ m}^3$$

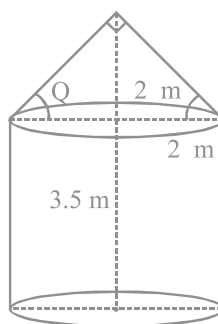

$(\frac{1}{2})$

(1)

OR

$$\text{Volume of water} = \frac{1}{3} \pi \times (5)^2 \times 8$$

$(\frac{1}{2})$

$$= \frac{200\pi}{3} \text{ cm}^3$$

(1)

$$\frac{1}{4} \text{th volume} = \frac{50\pi}{3} \text{ cm}^3$$

(1)

$$\text{Volume of one lead shot} = \frac{4}{3} \pi (0.5)^3 = \frac{0.5\pi}{3} \text{ cm}^3$$

$(\frac{1}{2})$

Let number of shots be n .

$$\text{Therefore, } \frac{0.5\pi}{3} \times n = \frac{50\pi}{3}$$

(1)

$$\text{i.e., } n = 100.$$

(1)

30.

CI	0-10	10-20	20-30	30-40	40-50	50-60	60-70	Total
f_i	4	5	7	10	12	8	4	50
x_i	5	15	25	35	45	55	65	
u_i	-3	-2	-1	0	1	2	3	
$f_i u_i$	-12	-10	-7	0	12	16	12	11
cf	4	9	16	26	38	46	50	

$(\frac{1}{2})$

$$\sum f_i = 50$$

$$\sum f_i u_i = 11$$

$$\text{Mean} = 35 + \frac{11}{50} \times 10 = 35 + 2.2 = 37.2 \quad (1)$$

$$\text{Median} = l + \left(\frac{\frac{n}{2} - cf}{f} \right) \times h \quad (\frac{1}{2})$$

$$= 30 + \frac{25 - 16}{10} \times 10 = 30 + 9 = 39 \quad (1)$$

$$\text{Mode} = l + \frac{f_1 - f_0}{2f_1 - f_0 - f_2} \times h \quad (\frac{1}{2})$$

$$= 40 + \frac{12 - 10}{24 - 10 - 8} \times 10 \quad (\frac{1}{2})$$

$$= 40 + \frac{20}{6} = 43.33 \quad (1)$$

OR

Writing as (1)

Daily income (in Rs)	cf
Less than 120	12
Less than 140	26
Less than 160	34
Less than 180	40
Less than 200	50

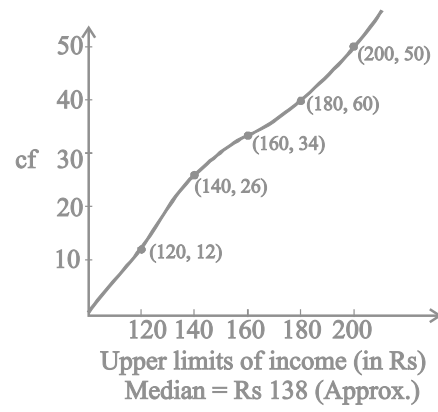

(5)

Note: Full credit should be given for alternative correct solution.

ANSWERS

EXERCISE 1.1

1. (C) 2. (D) 3. (C) 4. (B) 5. (A)
6. (B) 7. (C) 8. (A) 9. (D) 10. (D)

EXERCISE 1.2

1. No, because an integer can be written in the form $4q, 4q+1, 4q+2, 4q+3$.
2. True, because $n(n+1)$ will always be even, as one out of n or $(n+1)$ must be even.
3. True, because $n(n+1)(n+2)$ will always be divisible by 6, as at least one of the factors will be divisible by 2 and at least one of the factors will be divisible by 3.
4. No. Since any positive integer can be written as $3q, 3q+1, 3q+2$,
therefore, square will be $9q^2 = 3m, 9q^2 + 6q + 1 = 3(3q^2 + 2q) + 1 = 3m + 1,$
 $9q^2 + 12q + 3 + 1 = 3m + 1.$
5. No. $(3q + 1)^2 = 9q^2 + 6q + 1 = 3(3q^2 + 2q) + 1 = 3m + 1.$
6. HCF = 75, as HCF is the highest common factor.
7. $3 \times 5 \times 7 + 7 = 7(3 \times 5 + 1) = 7(16)$, which has more than two factors.
8. No, because HCF (18) does not divide LCM (380).

9. Terminating decimal expansion, because $\frac{987}{10500} = \frac{47}{500}$ and $500 = 5^3 \cdot 2^2$

$$\left[\frac{987}{10500} = \frac{329}{3500} = \frac{329}{2^2 \cdot 5^3 \cdot 7} = \frac{47}{2^2 \cdot 5^3} = .094. \right]$$

10. Since 327.7081 is a terminating decimal number, so q must be of the form $2^m \cdot 5^n$; m, n are natural numbers.

EXERCISE 1.3

8. 63 9. 625 12. 2520 cm 13. $2^3 \cdot 5^4, 0.0514$

EXERCISE 2.1

1. (A) 2. (C) 3. (D) 4. (D) 5. (B)
 6. (A) 7. (B) 8. (A) 9. (C) 10. (A)
 11. (D)

EXERCISE 2.2

1. (i) No (ii) $0, ax^2 + bx + c$ (iii) $\deg p(x) < \deg g(x)$
 (iv) $\deg g(x) \leq \deg p(x)$ (v) No
 2. (i) False (ii) False (iii) True (iv) True (v) True
 (vi) False (vii) False

EXERCISE 2.3

1. $1, -\frac{1}{4}$ 2. $\frac{2}{3}, -2$ 3. $-1, \frac{-7}{5}$ 4. $0, -3, 5$ 5. $\frac{-3}{2}, \frac{-1}{4}$
 6. $\frac{\sqrt{2}}{4}, \frac{-3\sqrt{2}}{2}$ 7. $\frac{1}{2}, \sqrt{2}$ 8. $\sqrt{3}, -5\sqrt{3}$ 9. $-2\sqrt{5}, \frac{\sqrt{5}}{2}$ 10. $\frac{2}{3}, -\frac{1}{7}$

EXERCISE 2.4

1. (i) $-2, \frac{2}{3}$ (ii) $\frac{5}{2}, \frac{1}{8}$ (iii) $-3\sqrt{3}, \sqrt{3}$ (iv) $\frac{\sqrt{5}}{5}, \frac{-\sqrt{5}}{2}$
 2. $a = -1$ and $b = 3$ or $a = 5, b = -3$. Zeroes are $-1, 2, 5$

3. $\frac{-\sqrt{2}}{2}, \frac{-2\sqrt{2}}{3}$ 4. $k = -3$

Zeroes of $2x^4 + x^3 - 14x^2 + 5x + 6$ are 1, -3, 2, $-\frac{1}{2}$

Zeroes of $x^2 + 2x - 3$ are 1, -3

5. $\sqrt{5}, \sqrt{5}, \sqrt{2}, \sqrt{5} - \sqrt{2}$ 6. $a = -1, b = -2$

1 and 2 are the zeroes of $q(x)$ which are not the zeroes of $p(x)$.

EXERCISE 3.1

- | | | | | |
|---------|---------|---------|--------|---------|
| 1. (D) | 2. (D) | 3. (C) | 4. (D) | 5. (D) |
| 6. (C) | 7. (C) | 8. (D) | 9. (D) | 10. (D) |
| 11. (C) | 12. (D) | 13. (C) | | |

EXERCISE 3.2

- | | | | |
|------------|----------|-------------|---------|
| 1. (i) Yes | (ii) No | (iii) No | |
| 2. (i) No | (ii) Yes | (iii) No | |
| 3. (i) No | (ii) Yes | (iii) Yes | (iv) No |
| 4. No | 5. False | 6. Not true | |

EXERCISE 3.3

- | | | |
|--|--|---|
| 1. (i) $\lambda = -1$ | (ii) $\lambda = 1$ | (iii) All real values of λ except ± 1 . |
| 2. $k = -6$ | 3. $a = 3, b = 1$ | |
| 4. (i) All real values of p except 10. | (ii) $p = 1$ | |
| (iii) All real values of p except $\frac{9}{10}$. | (iv) All real values of p except -4. | |
| (v) $p = 4, q = 8$ | | |
5. Do not cross each other.
6. $x - y = -4$
 $2x + 3y = 7$; infinitely many pairs.

7. $31, \frac{-5}{7}$ 8. $x = 1, y = 4$
9. (i) $x = 1.2, y = 2.1$ (ii) $x = 6, y = 8$ (iii) $x = 3, y = 2$
- (iv) $x = \frac{1}{6}, y = \frac{1}{4}$ (v) $x = 1, y = -1$ (vi) $x = a^2, y = b^2$
- (vii) $x = \frac{1}{2}, y = \frac{-3}{2}$
10. $x = 340, y = -165; -\frac{1}{2}$
11. (i) consistent; $x = -1, y = -1$ (ii) inconsistent
- (iii) consistent. The solution is given by $y = 3-x$, where x can take any value, i.e., there are infinitely many solutions.
12. $(2,0), (0,4), (0,-4); 8$ sq. units. 13. $x = y$; Infinitely many lines.
14. $a = 5, b = 2.$ 15. $55^\circ, 85^\circ.$
16. Salim's age = 38 years, Daughter's age = 14 years.
17. 40 years. 18. 40, 48. 19. 100 students in hall A, 80 students in hall B.
20. Rs 10, Rs 3. 21. 100.
22. $x = 20, y = 30, A = 130^\circ, B = 100^\circ, C = 50^\circ, D = 80^\circ$

EXERCISE 3.4

1. $x = 1, y = 4; 4:1$ 2. $(0,0), (4,4), (6,2)$ 3. 8 sq. units
4. $4x + 4y = 100, 3x = y + 15$, where Rs x and Rs y are the costs of a pen and a pencil box respectively; Rs 10, Rs 15 5. $(1,0), (2,3), (4,2)$ 6. 10 km/h, 40 km/h
7. 2.5 km/h 8. 10 km/h, 4 km/h 9. 83
10. Rs 2500, Rs 30 11. Rs 600, Rs 400
12. Rs 12000 in scheme A, Rs 10000 in scheme B 13. 500

EXERCISE 4.1

1. (D) 2. (C) 3. (C) 4. (A) 5. (B)
 6. (D) 7. (B) 8. (C) 9. (B) 10. (A)
 11. (C)

EXERCISE 4.2

1. (i) No, because discriminant $= -7 < 0$.
 (ii) Yes, because discriminant $= 9 > 0$.
 (iii) No, because discriminant $= 0$.
 (iv) Yes, because discriminant $= 4 > 0$.
 (v) No, because discriminant $= -64 < 0$.
 (vi) Yes, because discriminant $= (2 - 2\sqrt{2})^2 > 0$.
 (vii) Yes, because discriminant $= 1 > 0$.
 (viii) No, because discriminant $= -7 < 0$.
 (ix) Yes, because discriminant $= 1 > 0$.
 (x) Yes, because discriminant $= 8 > 0$.
2. (i) False, for example $x^2 = 1$ is a quadratic equation with two roots.
 (ii) False, for example $x^2 + 1 = 0$ has no real root.
 (iii) False, for example $x^2 + 1 = 0$ is a quadratic equation which has no real roots.
 (iv) True, because every quadratic polynomial has almost two zeroes.
 (v) True, because if in $ax^2 + bx + c = 0$, a and c have opposite signs, then $ac < 0$ and so $b^2 - 4ac > 0$.
 (vi) True, because if in $ax^2 + bx + c = 0$, a and c have same sign and $b = 0$, then $b^2 - 4ac = -4ac < 0$.
3. $x^2 - 3x + 1 = 0$ is an equation with integral coefficients but its roots are not integers.
4. $x^2 - 6x - 7 = 0$, which has roots $3 + \sqrt{2}, 3 - \sqrt{2}$
5. Yes. $\sqrt{3}x^2 - 7\sqrt{3}x - 12\sqrt{3} = 0$, which has roots 3, 4
6. No. 7. Yes

EXERCISE 4.3

1. (i) $\frac{5}{2}, -1$ (ii) $-1, -\frac{8}{5}$ (iii) $-\frac{4}{3}, 3$ (iv) $5, 2$
 (v) $-3\sqrt{2}, \sqrt{2}$ (vi) $\sqrt{5}, 2\sqrt{5}$ (vii) $\sqrt{11} - 3, \sqrt{11} - 3$
2. (i) $-\frac{3}{2}, \frac{2}{3}$ (ii) $-\frac{1}{2}, 3$ (iii) $\sqrt{2}, -\frac{\sqrt{2}}{6}$
 (iv) $\frac{\sqrt{5}}{3}, -2\sqrt{5}$ (v) $\frac{1}{21}, \frac{1}{21}$

EXERCISE 4.4

1. (i) Real roots exist; roots are $\frac{1}{2}, \frac{-3}{4}$
 (ii) Real roots exist; roots are $2, -\frac{1}{2}$
 (iii) Real roots exist; roots are $\frac{1}{5}, \frac{\sqrt{51}}{5}, \frac{1}{5}, -\frac{\sqrt{51}}{5}$
 (iv) Real roots exist; roots are $4 + \frac{3\sqrt{2}}{2}, 4 - \frac{3\sqrt{2}}{2}$
 (v) Real roots exist; roots are $-7\sqrt{5}, 2\sqrt{5}$
2. The natural number is 12
3. The natural number is 8
4. Original speed of the train is 45 km/h
5. Zeba's age now is 14 years
6. Nisha's age is 5 years and Asha's age is 27 years
7. Length of the pond is 34 m and breadth is 24 m
8. 14

EXERCISE 5.1

- | | | | | |
|---------|---------|---------|---------|---------|
| 1. (D) | 2. (B) | 3. (B) | 4. (B) | 5. (C) |
| 6. (B) | 7. (B) | 8. (B) | 9. (C) | 10. (A) |
| 11. (C) | 12. (D) | 13. (B) | 14. (C) | 15. (A) |
| 16. (A) | 17. (C) | 18. (A) | | |

EXERCISE 5.2

- (i), (iv) and (vii) form an AP as in each of these $a_{k+1} - a_k$ is the same for different values of k .
- False, as $a_4 - a_3 \neq a_3 - a_2$.
- Yes, $a_{30} - a_{20} = 30 - 20 = 10d = 40$.
- The difference between any two corresponding terms of such APs is the same as the difference between their first terms.
- No.
- No, as the total fare (in Rs) after each km is 15, 23, 31, 39, ---
- (i), (ii) and (iii) form an AP as in the list of numbers formed every succeeding term is obtained by adding a fixed number.
- (i) Yes (ii) No (iii) No

EXERCISE 5.3

- $(A_1) \rightarrow (B_4)$
 $(A_2) \rightarrow (B_5)$
 $(A_3) \rightarrow (B_1)$
 $(A_4) \rightarrow (B_2)$
- (i) $1, \frac{5}{4}, \frac{3}{2}$ (ii) $\frac{11}{3}, \frac{10}{3}, 3$ (iii) $4\sqrt{3}, 5\sqrt{3}, 6\sqrt{3}$
 (iv) $(a+2) + (b+1), (a+2) + (b+2), (a+3) + (b+2)$
 (v) $5a - 4, 6a - 5, 7a - 6$

3. (i) $\frac{1}{2}, \frac{1}{3}, \frac{1}{6}$ (ii) $-5, -8, -11$ (iii) $\sqrt{2}, \frac{3}{\sqrt{2}}, \frac{4}{\sqrt{2}}$
4. $a = -1, b = 15, c = 31$ 5. $3, 7, 11, 15, \dots$ 6. $d = -\frac{1}{5}, n = 27$
7. $1, 6, 11, 16, \dots$ 8. 126 10. Yes, 17th term. 11. $k = 0$
12. $67, 69, 71$ 13. $40^\circ, 60^\circ, 80^\circ$
14. 16th term; -21 15. -1 16. -78 17. 12th term
18. 73 19. 3 20. $n = 6, d = 10$
21. (i) -9400 (ii) $\frac{7n-1}{2}$ (iii) $\frac{111a-6b}{a-b}$ 22. 16th term; -632
23. -780 24. $5, 13, 21, \dots$ 25. $k = 27$ 27. -510
28. 100 29. 330 30. 1170 31. 504
32. $n = 5, 11$ 33. 11 34. Rs 800 35. 25 months.

EXERCISE 5.4

1. 970 2. (i) 12250 (ii) 12750 (iii) 75250
3. 3 4. $3, 7, 11, 15, \dots$ 5. (i) 1683 (ii) 13167
6. $1:3; 5:49$ 8. 50 9. Rs $3900; Rs 44500$
10. $728 \text{ m}; 26 \text{ m}.$

EXERCISE 6.1

1. (C) 2. (B) 3. (C) 4. (A) 5. (D)
6. (B) 7. (B) 8. (A) 9. (B) 10. (C)
11. (A) 12. (C)

EXERCISE 6.2

1. No, $25^2 \neq 5^2 \cdot 24^2$ 2. No, $D = R$ but $F \neq P.$
3. Yes, because $\frac{PA}{QA} = \frac{PB}{BR}$ 4. Yes, SAS criterion.

5. No, $\triangle QPR \sim \triangle STM$ 6. No, Corresponding sides must also be proportional.
 7. Yes, as the corresponding two sides and the perimeters are equal, their third sides will also be equal.
 8. Yes, AAA criterion. 9. No, ratio will be $\frac{9}{25}$.
 10. No, For this, $\angle P$ should be 90° .
 11. Yes, AA criterion.
 12. No, angles should be included angles between the two pairs of proportional sides.

EXERCISE 6.3

2. $x = 2$ 4. 9:1 6. $4\sqrt{3}$ cm 7. 18 cm
 8. 1:3 9. 60 cm 10. 108 cm^2 12. 12 cm
 13. $\frac{55}{3}$ cm 14. 10 m 15. 8 m

EXERCISE 6.4

1. 5 cm, 2 cm 2. $BC = 6.25$ cm, $EF = 16.8$ cm. 5. 0.8 m
 6. 8 km 7. 20.4 m 8. 9 m
 9. $2\sqrt{5}$ cm, 6 cm 10. $2\sqrt{5}$ cm, 5 cm, $3\sqrt{5}$ cm 14. 8 cm, 12 cm, 16 cm

EXERCISE 7.1

1. (B) 2. (B) 3. (C) 4. (B) 5. (C)
 6. (B) 7. (C) 8. (B) 9. (D) 10. (A)
 11. (B) 12. (D) 13. (B) 14. (A) 15. (A)
 16. (D) 17. (D) 18. (B) 19. (B) 20. (C)

EXERCISE 7.2

1. True. Because all three sides of both triangles are proportional.
 2. True. The three points lie on the line $x = -4$.
 3. False, since two points lie on the y -axis and one point lies in quadrant I.
 4. False. $PA = \sqrt{2}$ and $PB = \sqrt{10}$, i.e., $PA \neq PB$.
 5. True, since $\ar(\triangle ABC) = 0$.

6. False, since the diagonals donot bisect each other.
7. True, radius of the circle = 5 and $OP > 5$
8. False, since $AP \neq AQ$
9. True, since P divides AB in the ratio 1 : 2
10. True, since B divides AC in the ratio 2 : 7
11. False, since $PC = \sqrt{26} < 6$, P will lie inside the circle.
12. True, Mid-points of both the diagonals are the same and the diagonals are of equal length.

EXERCISE 7.3

1. Scalene triangle
2. (9, 0), (5, 0), 2 points
3. Rectangle
4. $a = -3$
5. (-3, 5) the middle point of AB. Infinite number of points. In fact all points which are solutions of the equation $2x+y+1=0$.
6. $\frac{-1}{2}, 0$, isosceles triangle
7. $\frac{19}{14}$
8. $y = -3, -5$, $PQ = \sqrt{290}$, $13\sqrt{2}$
9. 0
10. 6:7, $\frac{-34}{13}, 0$
11. 1:5
12. $a = 1$ $b = -3$
13. $k = 22$, $AB = 2\sqrt{61}$
14. $a = 5, 3$
15. 19
16. 11
17. $a = 2$, Area = 6 sq. unit
18. $\frac{4}{5}, \frac{21}{5}$
19. $2, \frac{1}{2}$
20. 8:1, $\frac{8}{3}, \frac{-1}{9}$

EXERCISE 7.4

1. $0, 3 - 4\sqrt{3}$ 2. $\frac{3}{4}$ sq. units.

3. (i) $\frac{x_2 - x_3}{2}, \frac{y_2 - y_3}{2}$ (ii) $\frac{x_1 - x_2 - x_3}{3}, \frac{y_1 - y_2 - y_3}{3}$

(iii) same as (ii)

(iv) same as (ii)

4. $a = -3, h = \frac{12\sqrt{26}}{13}$

5. Yes, Jaspal should be placed at the point (7, 5)

6. House to Bank = 5 km

Bank to school = 10 km

School to Office = 12 km

Total distance travelled = 27 km

Distance from house to office = 24.6 km

Extra distance = 2.4 km

EXERCISE 8.1

1. (B) 2. (A) 3. (B) 4. (C) 5. (B)
 6. (B) 7. (C) 8. (A) 9. (A) 10. (D)
 11. (B) 12. (C) 13. (C) 14. (B) 15. (A)

EXERCISE 8.2

1. True 2. False 3. False [$\sin 80^\circ - \sin 10^\circ = \text{positive}$: as θ increases, value of $\sin \theta$ increases]
 4. True 5. True 6. False 7. False 8. False
 9. False 10. False 11. False 12. True

EXERCISE 8.3

8. 30° 9. $\frac{-1}{2}$ 10. $\frac{15}{2}$ m 11. 1 12. 90° 14. 45°

EXERCISE 8.4

3. $10\sqrt{3}$ m 7. $25\sqrt{3}$ m 13. $10\sqrt{3}$ m; 10 m 14. $h(\cot \alpha - \cot \beta)$
 16. $5(\sqrt{3}+3)$ m 18. 8 m

EXERCISE 9.1

1. (B) 2. (D) 3. (C) 4. (A) 5. (D)
 6. (C) 7. (A) 8. (A) 9. (D) 10. (B)

EXERCISE 9.2

1. False 2. False 3. True 4. True 5. True
 6. False 7. True 8. False 9. True 10. True

EXERCISE 9.3

1. 3 cm

EXERCISE 9.4

3. 20 cm 5. 4.8 cm 7. 30° 11. $\frac{20}{3}$ cm
 12. 70° 13. $8\sqrt{2}$ cm² 14. 24 cm

EXERCISE 10.1

1. (D) 2. (B) 3. (A) 4. (C) 5. (B)
 6. (D)

EXERCISE 10.2

1. True 2. False 3. False 4. True

EXERCISE 10.3

2. Yes 7. No

EXERCISE 10.4

1. 3.25 cm 2. Yes, yes 3. 4 cm 6. 8 cm

EXERCISE 11.1

1. (B) 2. (A) 3. (B) 4. (A) 5. (B)
6. (A) 7. (D) 8. (B) 9. (C) 10. (D)

EXERCISE 11.2

1. No, radius of the circle is $\frac{a}{2}$
2. Yes, side of the square is $2a$ cm
3. No, side of the outer square = diagonal of the inner square
4. No, it is only true for minor segment.
5. No, it is πd .
6. Yes, distance covered in one revolution = $2\pi r$
7. No, it will depend on the value of radius.
8. Yes, it will be true for the arcs of the same circle.
9. No, it will be true for the arcs of the same circle.
10. No, it will be true for arcs of the same circle.
11. Yes, radius of the circle breadth of the rectangle.
12. Yes, their radii are equal
13. Yes, their radii are equal
14. No, diagonal of the square is p cm.

EXERCISE 11.3

1. 33 cm 2. $(16\pi - 32)$ cm² 3. 308 cm²
4. 500. 5. 154 m² 6. $(380 + 25\pi)$ cm²
7. 54.5 cm² 8. $(32 + 2\pi)$ m² 9. $(248 - 4\pi)$ m²

10. $\frac{308}{3} - 49\sqrt{3}$ cm² 11. 30.96 cm² 12. 39.25 cm²
 13. 308 cm² 14. 15246 m² 15. 1386 cm² 16. $\frac{60}{\pi}$ cm

EXERCISE 11.4

1. Rs 26400 2. 560 3. $24\sqrt{21} - 77$ m²
 4. $75.36 - 36\sqrt{3}$ cm² 5. Rs 3061.50 6. 196 cm²
 7. 1.967 cm²(approx) 8. 8.7 cm² 9. 42 cm²
 10. 168 cm² 11. 4.3 m² 12. 800 cm² 13. 1 : 3 : 5
 14. $45\frac{5}{6}$ cm² 15. $73\frac{1}{3}$ cm, Areas: $\frac{154}{3}$ cm², 154 cm²; Arc lengths: $\frac{44}{3}$ cm;

Arc lengths of two sectors of two different circles may be equal, but their area need not be equal.

17. $180 - 8\pi$ cm² 18. 40 19. $\frac{25\pi}{4} + \frac{25}{2}$ cm² 20. 462 cm²

EXERCISE 12.1

1. (A) 2. (A) 3. (B) 4. (B) 5. (C)
 6. (D) 7. (A) 8. (A) 9. (B) 10. (A)
 11. (B) 12. (C) 13. (A) 14. (A) 15. (A)
 16. (B) 17. (C) 18. (A) 19. (A) 20. (D)

EXERCISE 12.2

1. False 2. False 3. False 4. False 5. False
 6. True 7. False 8. True

EXERCISE 12.3

1. 6 cm 2. 84 3. 15 cm 4. 7:1 5. 160 cm²
 6. 277 cm³ 7. 855 cm² (approx.)
 8. 14 cm, 7 cm; 132 cm³, 66 cm³; 396 cm³ 9. 327.4 cm³

- 10.** 150 **11.** 1500 **12.** 2541 **13.** 12960 **14.** 450

EXERCISE 12.4

- 1.** 28.44 cm **2.** 8.6 m **3.** 3960 cm³, 29.7 kg **4.** 480000 words
5. 51 minutes 12 sec **6.** 74.25m³, 80.61 m² **7.** Rs 2250
8. 2 hours **9.** 112 m **10.** 0.5 cm **11.** 487.6 cm³
12. Rs 230.12 **13.** 36 cm, 43.27 cm **14.** 301.44 cm², 377.1 cm³
15. 4 m **16.** 54 **17.** 1.584 m³
18. 90 cm **19.** 2.5 cm **20.** 170.8 cm³

EXERCISE 13.1

- 1.** (C) **2.** (B) **3.** (A) **4.** (C) **5.** (B)
6. (B) **7.** (B) **8.** (C) **9.** (C) **10.** (C)
11. (A) **12.** (D) **13.** (D) **14.** (A) **15.** (C)
16. (B) **17.** (C) **18.** (A) **19.** (A) **20.** (A)
21. (D) **22.** (B) **23.** (C) **24.** (A) **25.** (C)
26. (B)

EXERCISE 13.2

- Not always, because for calculating median of a grouped data, the formula used is based on the assumption that the observations in the classes are uniformly distributed (or equally spaced).
- Not necessary, the mean of the data does not depend on the choice of a (assumed mean).
- No, it is not always the case. The values of these three measures can be the same. It depends on the type of data.
- Not always. It depends on the data.
- No, the outcomes are not equally likely. For example, outcome 'one girl' means gbb , bgb , bbg 'three girls' means ggg and so on.
- No, the outcomes are not equally likely. The outcome '3' is more likely than the others.

- 7.** Peehu; probability of Apoorv's getting 36 $\frac{1}{36}$ while probability of Peehu's getting

$$36 \frac{1}{6} \frac{6}{36}.$$

8. Yes, the probability of each outcome is $\frac{1}{2}$, since the two outcomes are equally likely.
9. No, outcomes '1' and 'not 1' are not equally likely, $P(1) = \frac{1}{6}$, $P(\text{not } 1) = \frac{5}{6}$,
10. No, the outcomes are not equally likely. Outcome 'no head' means 'TTT'; outcome 'one head' means THT, HTT, TTH and so on. $P(\text{TTT}) = \frac{1}{8}$, $P(\text{one head}) = \frac{3}{8}$ and so on.
11. No, the outcomes 'head' and 'tail' are equally likely every time regardless of what you get in a few tosses.
12. It could be a tail or head as both the outcomes are equally likely, in each toss.
13. No, head and tail are equally likely. So, no question of expecting a tail to have a higher chance in the 4th toss.
14. Yes, the outcomes 'odd number', 'even number' are equally likely in the situation considered.

EXERCISE 13.3

1. 5.5 2. 35 3. 12.93 4. 26 5. Rs. 356.5
6. 109.92 7. 123.4 kg 8. 14.48 km/l; No, the manufacturer is claiming mileage 1.52 km/h more than the average mileage

9.

Weight (in kg)	Number of persons
Less than 45	4
Less than 50	8
Less than 55	21
Less than 60	26
Less than 65	32
Less than 70	37
Less than 75	39
Less than 80	40

10.

Marks	Number of students
0-10	10
10-20	40
20-30	80
30-40	140
40-50	170
50-60	130
60-70	100
70-80	70
80-90	40
90-100	20

11.

Marks	Number of candidates
0-10	2
10-20	2
20-30	3
30-40	4
40-50	6
50-60	6
60-70	5
70-80	2
80-90	4

12. $a = 12, b = 13, c = 35, d = 8, e = 5, f = 50$

13.

(i) Less than type		(ii) More than type	
Ages (in years)	Number of students	Ages (in years)	Number of students
Less than 10	0	More than or equal to 10	300
Less than 20	60	More than or equal to 20	240
Less than 30	102	More than or equal to 30	198
Less than 40	157	More than or equal to 40	143
Less than 50	227	More than or equal to 50	73
Less than 60	280	More than or equal to 60	60
Less than 70	300		

14.

Marks	Number of students
0-20	17
20-40	5
40-60	7
60-80	8
80-100	13

15. Rs 1263.15**16.** 109.17 km/h**17.** Rs 11875**18.** 201.7 kg**19.** (i) $\frac{1}{6}$ (ii) $\frac{5}{6}$ **20.** (i) $\frac{1}{6}$ (ii) $\frac{5}{12}$ (iii) 0**21.** (i) $\frac{1}{9}$ (ii) $\frac{1}{9}$ (iii) 0**22.** $\frac{4}{9}$ **23.** $P(2)=\frac{1}{18}$, $P(3)=\frac{1}{9}$, $P(4)=\frac{1}{6}$, $P(5)=\frac{1}{6}$, $P(6)=\frac{1}{6}$, $P(7)=\frac{1}{6}$, $P(8)=\frac{1}{9}$ $P(9)=\frac{1}{18}$ **24.** $\frac{3}{4}$ **25.** (i) $\frac{1}{8}$ (ii) $\frac{1}{2}$ **26.** $\frac{2}{9}$ **27.** (i) $\frac{5}{11}$ (ii) $\frac{7}{22}$ (iii) $\frac{17}{22}$

28. (i) $\frac{13}{49}$ (ii) $\frac{3}{49}$ 29. (i) $\frac{10}{49}$ (ii) $\frac{1}{49}$
30. (i) $\frac{1}{10}$ (ii) $\frac{3}{10}$ (iii) $\frac{3}{5}$
31. (i) $\frac{14}{99}$ (ii) $\frac{85}{99}$ 32. (i) $\frac{1}{2}$ (ii) $\frac{9}{100}$
33. $\frac{21}{26}$ 34. 0.69 35. $\frac{11}{75}$
36. P (not defective) = $\frac{3}{4}$, P (2nd bulb defective) = $\frac{5}{23}$
37. (i) $\frac{4}{9}$ (ii) $\frac{5}{9}$ (iii) $\frac{1}{3}$ (iv) $\frac{5}{18}$
38. (i) $\frac{1}{8}$ (ii) $\frac{1}{8}$ (iii) $\frac{3}{4}$
39. (i) 5 scores (0, 1, 2, 6, 7, 12) (ii) $\frac{1}{3}$
40. (i) $\frac{7}{8}$ (ii) $\frac{15}{16}$ 41. (i) $\frac{5}{6}$ (ii) $\frac{1}{3}$
42. (i) 0.009 (ii) $\frac{8}{999}$

[Hint : (ii) After first player has won the prize the number of perfect squares greater than 500 will be reduced by 1]

EXERCISE 13.4

1. 51.75 2. 48.41 3. 31 years 4. 201.96 g
7. Median salary = Rs 13420, Modal salary = Rs 12730
8. $f_1 = 28, f_2 = 24$ 9. $p = 5, q = 7$
11. Median = 17.81 hectares, Mode = 17.76 hectares
12. Median rainfall = 21.25 cm
13. average = 170.3 sec.

14. (i)

Distance (in m)	No. of students	Cummulative frequency
0-20	6	6
20-40	11	17
40-60	17	34
60-80	12	46
80-100	4	50

(iii) 49.41 m.