



WINTER-15 EXAMINATION
Model Answer

Subject code :(17561)

Page 1 of 25

Important Instructions to examiners:

- 1) The answers should be examined by key words and not as word-to-word as given in the model answer scheme.
- 2) The model answer and the answer written by candidate may vary but the examiner may try to assess the understanding level of the candidate.
- 3) The language errors such as grammatical, spelling errors should not be given more Importance (Not applicable for subject English and Communication Skills).
- 4) While assessing figures, examiner may give credit for principal components indicated in the figure. The figures drawn by candidate and model answer may vary. The examiner may give credit for any equivalent figure drawn.
- 5) Credits may be given step wise for numerical problems. In some cases, the assumed constant values may vary and there may be some difference in the candidate's answers and model answer.
- 6) In case of some questions credit may be given by judgement on part of examiner of relevant answer based on candidate's understanding.
- 7) For programming language papers, credit may be given to any other program based on equivalent concept.



WINTER-15 EXAMINATION
Model Answer

Subject code :(17561)

Page 2 of 25

Q No.	Answer	marks	Total marks																		
1A	Attempt any three		12																		
1A-a	Definition: Static characteristics: Static characteristics are those that must be considered when the instrument is used to measure a condition not varying with time. Dynamic characteristics: Dynamic characteristics are those that must be considered when the instrument is used to measure a condition varying with time.	2 2	4																		
1A-b	Different temperature scales 1. Centigrade or Celsius 2. Kelvin 3. Fahrenheit 4. Rankine, 5. Reaumur <table border="1"><thead><tr><th>Temperature scale</th><th>Ice point</th><th>Steam point</th></tr></thead><tbody><tr><td>Centigrade or Celsius</td><td>0°C</td><td>100°C</td></tr><tr><td>Kelvin</td><td>273K</td><td>373K</td></tr><tr><td>Fahrenheit</td><td>32°F</td><td>212°F</td></tr><tr><td>Rankine</td><td>491.69°R¹</td><td>671.69°R¹</td></tr><tr><td>Reaumur</td><td>0°R</td><td>80°R</td></tr></tbody></table>	Temperature scale	Ice point	Steam point	Centigrade or Celsius	0°C	100°C	Kelvin	273K	373K	Fahrenheit	32°F	212°F	Rankine	491.69°R ¹	671.69°R ¹	Reaumur	0°R	80°R	½ marks each for any four. ½ marks each for any four.	4
Temperature scale	Ice point	Steam point																			
Centigrade or Celsius	0°C	100°C																			
Kelvin	273K	373K																			
Fahrenheit	32°F	212°F																			
Rankine	491.69°R ¹	671.69°R ¹																			
Reaumur	0°R	80°R																			

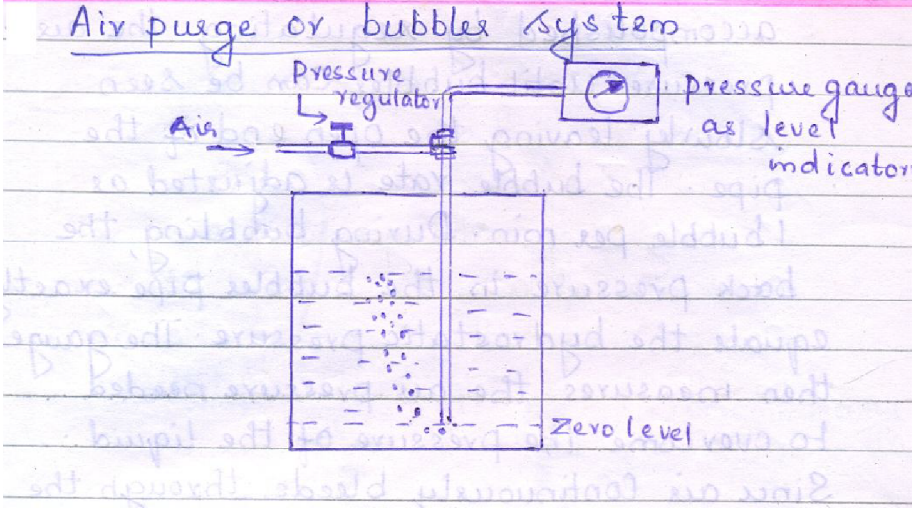

WINTER-15 EXAMINATION
Model Answer

1A-c	 <p>Methods for indirect level measurement(any four): Pressure gauge, air purge, radioactive, ultrasonic, capacitive</p>	2	4
1A-d	<p>Classification of flow meter: flowmeters are classified into</p> <p>A. Inferential flow meters:</p> <ol style="list-style-type: none">1) Differential pressure meters(head meter)2) Variable area meter3) Electromagnetic flow meter4) Velocity flow meter5) Ultrasonic flow meters <p>B. Quantity flow meters:</p> <ol style="list-style-type: none">1) Mass flow meter2) Positive displacement flow meter.	4	4
1B	Attempt any one		6
1B-a	LVDT Diagram:		6



WINTER-15 EXAMINATION
Model Answer

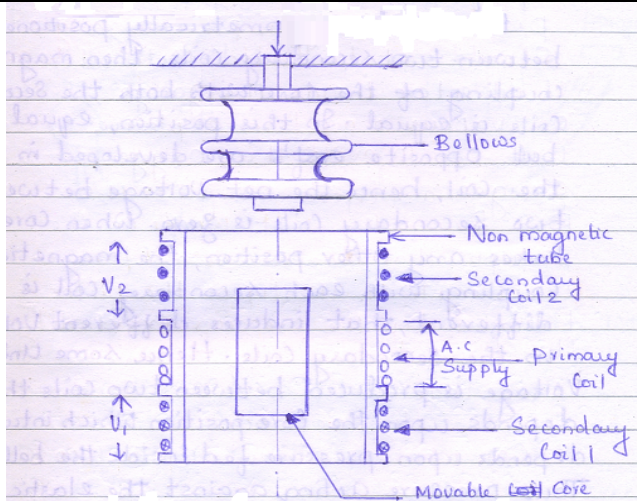

Working

When the pressure inside the bellows changes, its free end gets deflected along with the movable core. When the core is symmetrically positioned between the two secondary coils, the magnetic coupling of the core with both the secondary coils is equal. In this position, equal but opposite emfs are developed in the coils, and hence the net voltage between two secondary coils is zero. When the core takes any other position, the magnetic coupling with each secondary coil is different, that induces different voltages in the secondary coils. Hence some unbalance voltage is produced between the coils that depends upon the position of the core which in turn depends upon the pressure fed inside the bellows. Thus it converts the displacement due to the pressure applied into an electrical signal.

3

3

1B-b Cascade control system

6



WINTER-15 EXAMINATION
Model Answer

Block diagram:

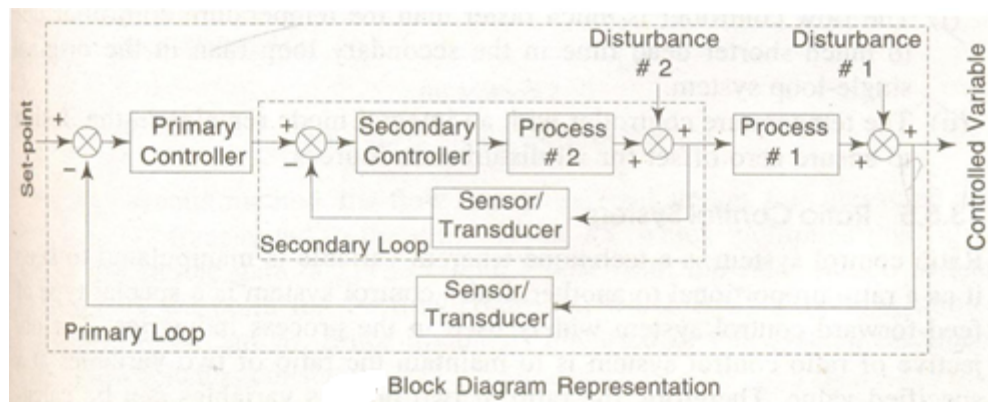

Description:

In a cascade control system, there is one manipulated variable and more than one measurement. It employs 2 feedback controllers, with the output of the master (primary) controller changing the set point of the slave (or secondary) controller. It eliminates the effect of disturbances and improves the dynamic response of control loop. The feedback controller attempts to maintain the process variable at its set point in response to all the disturbances and ensures zero steady state offset for step like disturbances. Cascade control system considers the likely disturbances and tune the control system to the disturbances that strongly degrades the performance. It uses an additional secondary measured process input variable that has the important characteristics of indicating occurrence of the key disturbances.

3

3

2 **Attempt any four**

16

2-a **Difference between Open loop and closed loop control system:**

1 mark
each for
any four.

4

Sr No.	Open loop control system	Closed loop control system
1	Feedback doesn't exist	Feedback exists
2	Output measurement is not	Output measurement is



WINTER-15 EXAMINATION
Model Answer

	necessary	necessary		
3	Any change in output has no effect on input	Changes in output affects the input		
4	Error detector is absent	Error detector is present		
5	Inaccurate and unreliable	Highly accurate and reliable		
6	Highly sensitive to disturbance	Less sensitive to disturbance		
7	Highly sensitive to environmental changes	Less sensitive to environmental changes		
8	Simple in construction and cheap	Complicated in construction and hence costly		
9	Highly affected by non-linearities	Reduced effect of non-linearity		

2-b

Dead weight tester:
Diagram:

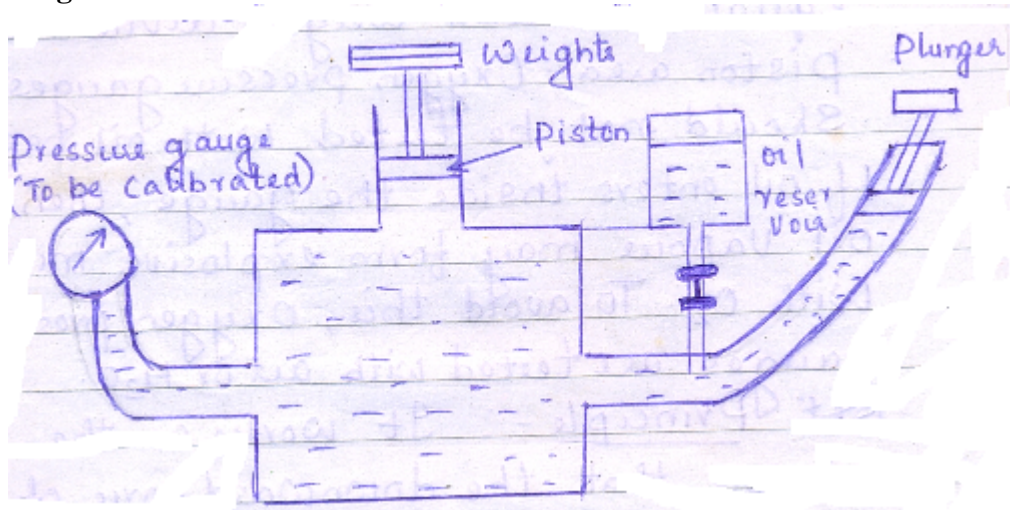

Working:

It consists of a cylinder with piston, displacement pump to suck the oil from the

2

4



WINTER-15 EXAMINATION
Model Answer

Subject code :(17561)

Page 7 of 25

	reservoir on upward stroke and pressurize the oil on downward stroke and the gauge to be tested. At the top of the piston, there is a platform on which standard known weights are placed. The weight pressurizes the oil into pressure gauge. The pressure in the tester is build up till the weights are seemed to float, when the fluid gauge pressure equals the dead weight divided by piston area.	2	
2-c	Function of valve positioner: When static frictional forces are large, valve positioner is used along with actuator so as to correctly position the valve stem in response to the control signal. Valve positioner improves the speed of response and reduces the hysteresis effect. Function of valve actuator: it is that portion of the valve that responds to the applied signal and results in the movement of the stem due to which the flow rate of fluid changes.	2 2	4
2-d	Functions of Computer aided Process Control System: following are the functions. 1) Measurement and data acquisition 2) Data conversion with scaling and checking 3) Data accumulation and formatting 4) Visual display 5) Comparing with limits and alarm raising 6) Recording and monitoring of events, sequence and trends 7) Data logging and computation 8) Control action	1 mark each for any four.	4
2-e	Application of PLC: 1) PLC can be a vital part of industrial automation as it produces on/off voltage outputs to actuate elements such as electric motors, solenoids etc.	2	4

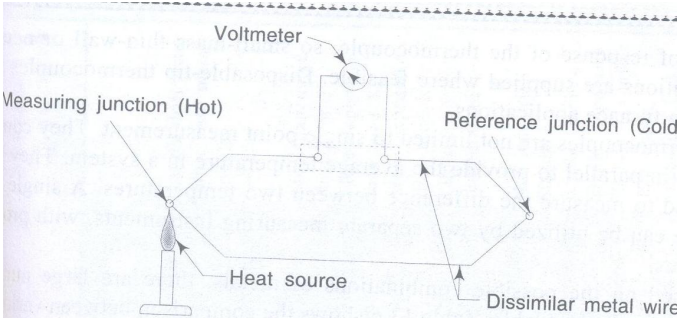

WINTER-15 EXAMINATION
Model Answer

	<p>2) It can also be used in sequential controllers used for periodical on/off of fans, heaters and light switches.</p> <p>Application Of DCS:</p> <p>1) DCS are designed for continuous process where the control signal is analog rather than discrete.</p> <p>2) It is a powerful integrated control system having capabilities such as, data acquisition, advanced process control and batch control capabilities for various industrial environments such as cement factory, oil refinery, power plant etc.</p>	2	
2-f	<p>Importance of valve sizing:</p> <p>Valve sizing is important for using the appropriate size valve for various applications. For a fixed flow rate, ideal valve will be the one that will function between 40% and 70% of the full operating range so that for maximum flow, it is not wide open and for minimum flow not closing down too near its seated position. For handling liquids with low flash point, oversize valves are normally employed. For valve sizing, the maximum flow considered should be the required maximum flow and not the full capacity of the valve.</p>	4	4
3	<p>Attempt any four</p>		16
3-a	<p>Thermocouple Diagram</p> 	2	4



WINTER-15 EXAMINATION
Model Answer

Subject code :(17561)

Page 9 of 25

	<p>Working: The working principle of a thermocouple depends on the thermo-electric effect. If two dissimilar metals are joined together so as to form a closed circuit, there will be two junctions where they meet each other. If one of these junctions is heated, then, a current flows in the circuit which can be detected by a galvanometer. The amount of the current produced depends on the difference in temperature between the two junctions and on the characteristics of the two metals. This was first observed by Seebeck in 1821 and is known as Seebeck effect.</p>	2										
3-b	<p>Difference between direct and indirect level measurement</p> <table border="1"><thead><tr><th>SR. NO.</th><th>DIRECT LEVEL MEASUREMENT</th><th>INDIRECT LEVEL MEASUREMENT</th></tr></thead><tbody><tr><td>1</td><td>Simple method of measuring liquid level</td><td>Complex method of measuring liquid level</td></tr><tr><td>2</td><td>Ex. 1) Hook type level indicator 2) Sight glass 3) Float type</td><td>Ex. 1) hydrostatic pressure type 2) Electrical method</td></tr></tbody></table>	SR. NO.	DIRECT LEVEL MEASUREMENT	INDIRECT LEVEL MEASUREMENT	1	Simple method of measuring liquid level	Complex method of measuring liquid level	2	Ex. 1) Hook type level indicator 2) Sight glass 3) Float type	Ex. 1) hydrostatic pressure type 2) Electrical method	2 marks each	4
SR. NO.	DIRECT LEVEL MEASUREMENT	INDIRECT LEVEL MEASUREMENT										
1	Simple method of measuring liquid level	Complex method of measuring liquid level										
2	Ex. 1) Hook type level indicator 2) Sight glass 3) Float type	Ex. 1) hydrostatic pressure type 2) Electrical method										
3-c	<p>Elastic pressure transducer: In Elastic pressure transducers use elastic primary sensing element such as the bourdon tube, bellows, and diaphragm that converts pressure in to proportional mechanical displacement. Bourdon tube for pressure measurement.</p>	1	4									



WINTER-15 EXAMINATION
Model Answer

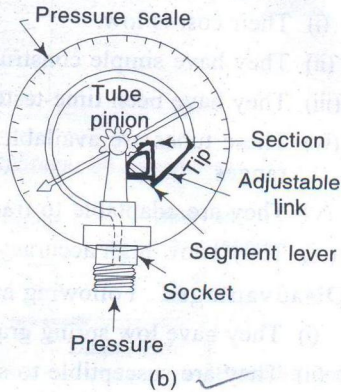

As the fluid under pressure enters the bourdon tube, it tries to change the section of tube from oval to circular, and this tend to straighten out the tube The resulting movement of the free end of the tube causes the pointer to move over the scale. The tip of the bourdon tube is connected to a segmental lever through an adjustable length link. The lever length also is adjustable. The segmental lever end on the segment side is provided with a rack which meshes to a suitable pinion mounted on spindle. The segmental lever is suitably pivoted and the spindle holds the pointer. A hairspring is sometimes used to fasten the spindle to the frame of the instrument to provide the necessary tension for proper meshing of the gear teeth,thereby freeing the system from backlash. Bourdon tubes are made from materials such as phosphor bronze, alloy steel, stainless steel, monel metal, and beryllium copper.

3

3-d

Ultrasonic flow meter
Diagram

4



WINTER-15 EXAMINATION
Model Answer

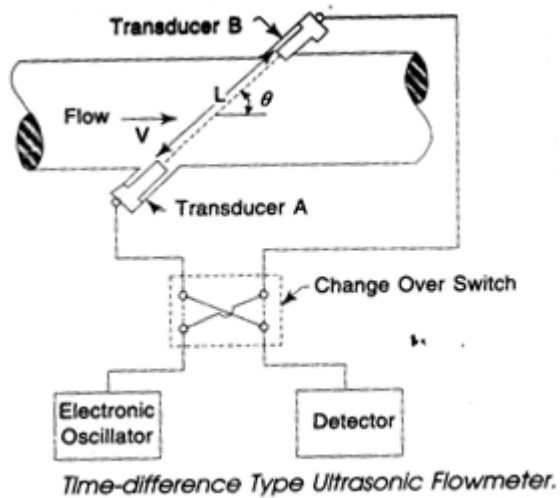

Time-difference Type Ultrasonic Flowmeter.

Working:

In ultrasonic flow meters, the measurement of flow rate is determined by the variation in parameters of ultrasonic oscillations

Time Difference Type ultrasonic flow meters measure flow by measuring the time taken for ultrasonic wave to transverse a pipe section, both with and against the flow of liquid within the pipe. It consists of two transducers, A and B, inserted into a pipe line, and working both as transmitter and receiver, as shown in Fig.. The ultrasonic waves are transmitted from transducer A to transducer B and vice versa. An electronic oscillator is connected to supply ultrasonic waves alternately to A or B which is working as transmitter through a changeover switch, when the detector is connected simultaneously to B or A which is working as receiver. The detector measures the transit time from upstream to downstream transducers and vice versa.

The time T_{AB} for ultrasonic wave to travel from transducer A to transducer B is given by the expression:

2

2



WINTER-15 EXAMINATION
Model Answer

$$T_{AB} = \frac{L}{(C + V \cos \theta)}$$

and, the time (T_{BA}) to travel from B to A is given as,

$$T_{BA} = \frac{L}{(C - V \cos \theta)}$$

where, L = the acoustic path length between A and B

C = velocity of sound in the fluid

θ = angle of path with respect to the pipe axis

V = velocity of fluid in pipe

The time difference between T_{AB} and T_{BA} can be calculated as,

$$\Delta T = T_{AB} - T_{BA} = \frac{2LV \cos \theta}{C}$$

$$V = \Delta T C / 2L \cos \theta$$

3-e

System input for

i) Step :

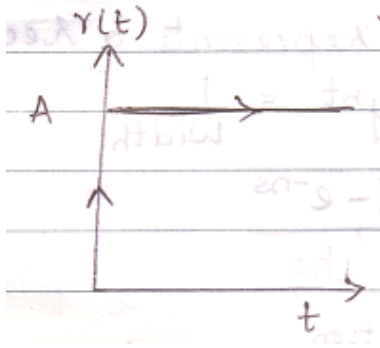

ii) Sinusoidal :

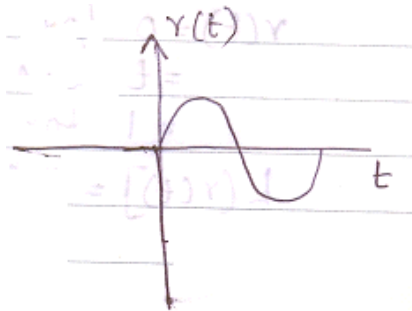

iii) Ramp :

1 mark
each

4



WINTER-15 EXAMINATION
Model Answer

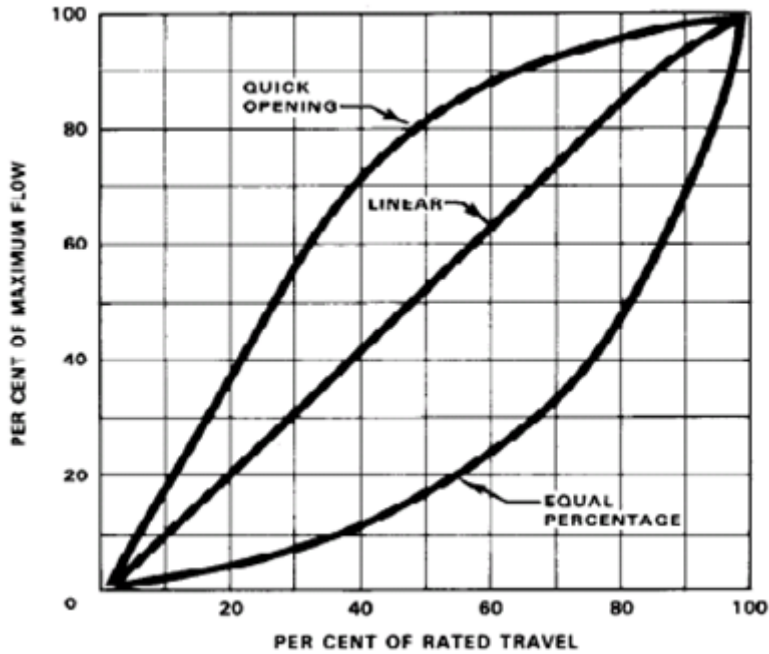

2

Inherent flow characteristics are plotted when constant pressure drop is maintained across the valve. There are two different inherent flow characteristics- linear and equal percent.

Linear Opening characteristics: Linear characteristics valve has linear relation between valve opening and flow rate at constant pressure drop

$$Q = by$$

Q- Flow rate at constant pressure drop

b - constant

y - valve opening / valve stem travel

Generally used

- For slow process
- When more than 40% of the system pressure drop occurs across the valve.

Equal Percentage characteristics: In equal percentage valve equal increment

4



WINTER-15 EXAMINATION
Model Answer

Subject code :(17561)

Page 17 of 25

	<p>of the stem travels give equal % change of the existing flow</p> $Q = be^{ay}$ <p>Q= Flow rate at constant pressure drop a& b = constant e = base of natural logarithms y = valve opening / valve stem travel</p> <p>Generally used</p> <ul style="list-style-type: none">• For fast processes• When high rangeability is required <p>At heat exchangers where an increase in product rate requires much greater increase in heating and cooling medium.</p> <p>Installed flow characteristics are plotted when the differential pressure across the valve changes.</p> <p>Quick opening – In this there is maximum flow for minimum travel</p> <p>It is approximately linear when the flow rate is less but beyond 30% the flow increases rapidly with valve opening</p> <p>It gives approximately 90% flow at 30% travel</p> <ul style="list-style-type: none">• For on – off control <p>When maximum valve capacity must be obtained quickly.</p>		
4B-b	<p>PID controller</p> <p>Diagram</p>		6



WINTER-15 EXAMINATION
Model Answer

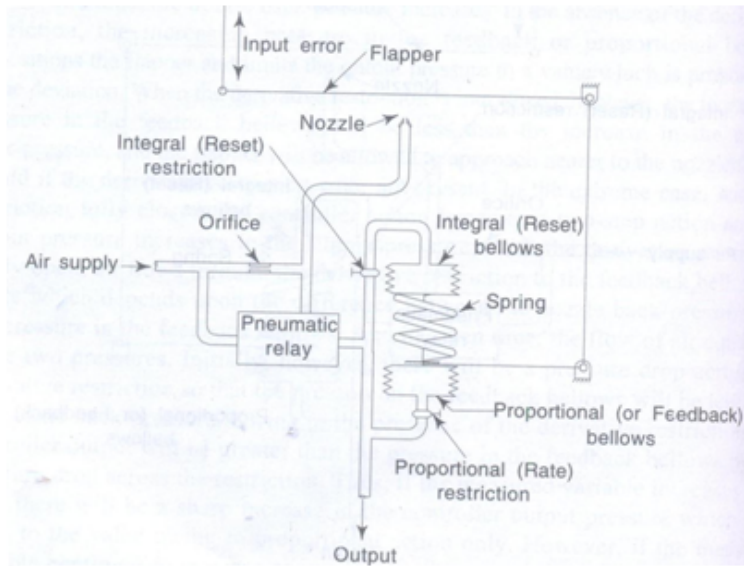

Description:

Pneumatic PID controller are made of Pneumatic flapper nozzle which is a displacement type pneumatic detector. It has been seen that the rate action can be obtained by causing the feedback pressure to lag the output pressure and reset action can be obtained by use of positive feedback pressure which lags the output while the negative feedback pressure is the same as the output pressure. By causing both the positive and the negative feedback to lag the output pressure, both rate and reset action may be obtained which is known as proportional plus integral plus derivative controller as shown in fig above.

3

3

5	Attempt any four		16
5-a	Flow meter for high viscosity fluid material: Cylinder and piston type flow meter Diagram:	1	4

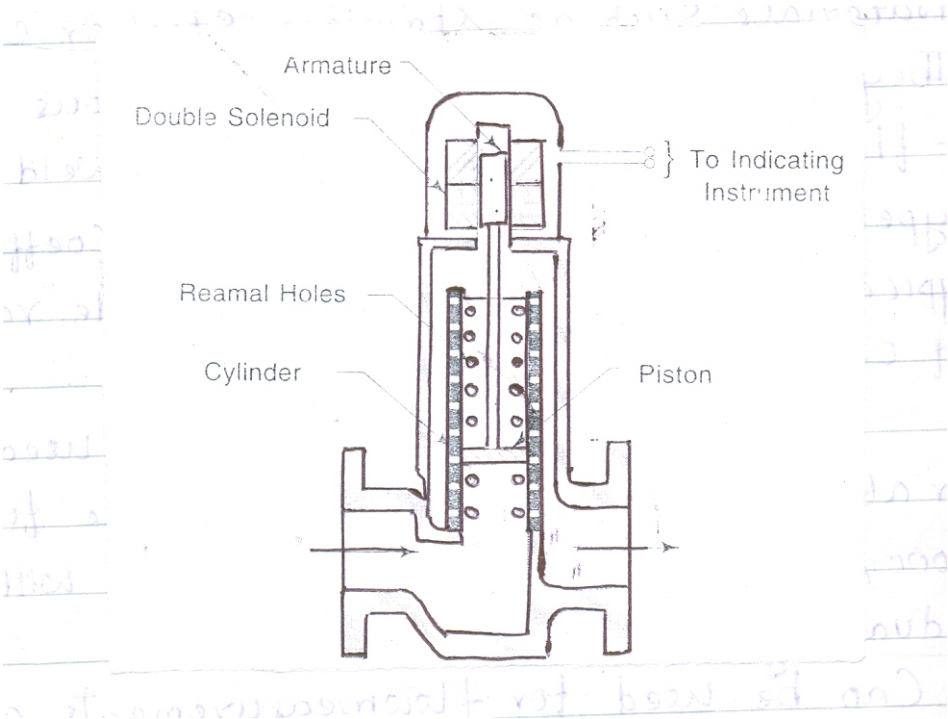

WINTER-15 EXAMINATION
Model Answer

	 <p>Construction: It consists of a cylinder and a piston fitted into it. A series of reamed holes are provided in the walls of the cylinder to provide passage for fluid flow. These holes are spaced helically around the cylinder in rows to provide a continuous variation in area for various heights of the piston.</p>	1½ marks	
5-b	<p>Principle of pressure gauge: Pressure gauge works on hydrostatic principle. When liquid is held in a tank, then it exerts equal pressure on the walls of the tank. Such a pressure is due to the weight of liquid present above a certain reference point or base and is called hydrostatic head or pressure.</p> <p>Disadvantages: 1) Low spring gradient</p>	2 1 mark each for	4

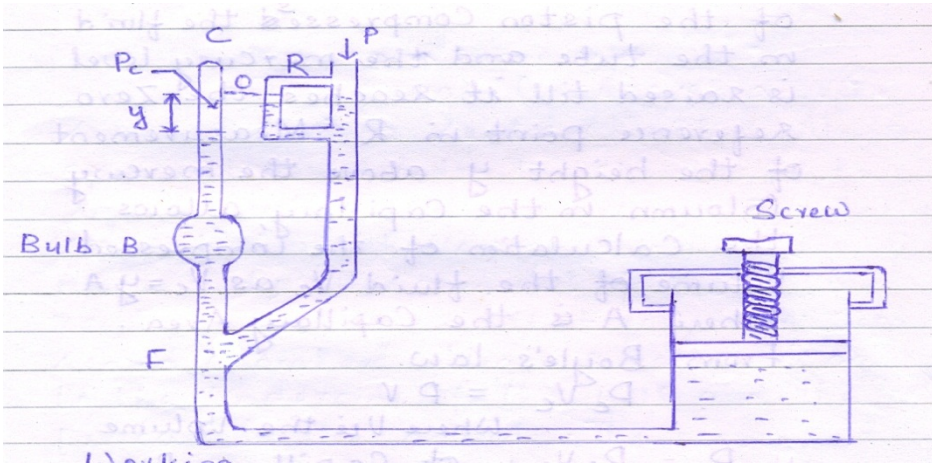

WINTER-15 EXAMINATION
Model Answer

	<p>2) Susceptible to shock and vibration</p> <p>3) Large hysteresis effect</p>	any 2	
5-c	<p>McLeod gauge is used for measuring pressure in the range of 10^{-1} to 10^{-5} torr.</p> <p>Diagram:</p>  <p>Working:</p> <p>To operate the gauge, the piston is first withdrawn, causing the level of mercury in the lower part of the gauge to fall below the level of the junction between the two tubes. The unknown pressure source is connected to the gauge from where it also flows and fills the bulb and capillary. Next, the piston is pushed in, moving the mercury level up to block the junction. At this stage,, the fluid in the capillary and the bulb is at pressure P. Further movement of the piston compresses the fluid in the tube and the mercury level is raised till it reaches the zero reference point in R. Measurement of the height above the mercury column in the capillary allows the calculation of the compressed volume of the fluid.</p> <p>The expression for calculating the unknown pressure is</p> $P = A\rho gy^2 / V$ <p>Where A is capillary area</p>	1	4
		1½ marks	
		1½ marks	

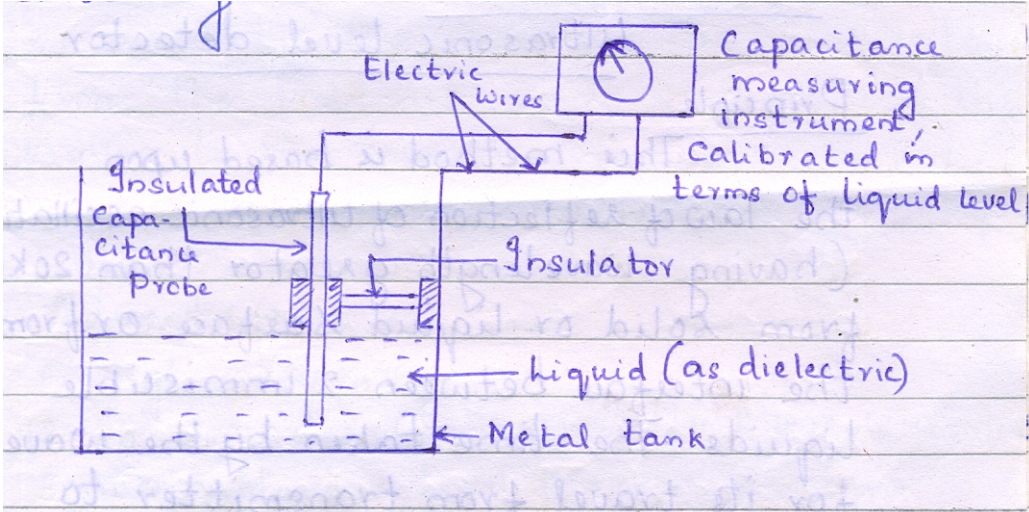

WINTER-15 EXAMINATION
Model Answer

	<p>ρ is density of fluid y is height above the mercury column in capillary</p>		
5-d	<p>Measurement of solid level : Capacitance level detector Diagram</p>  <p>Construction & Working: It consists of two conductors separated from each other by dielectric material between them. There is an insulated capacitance probe fixed near and parallel to tank wall such that the probe and metal tank wall acts as conductors with conducting solids as the dielectric medium. These two conductors are connected to capacitance detecting element. As the solid level changes, the dielectric constant changes due to which capacitance changes. Thus any change in solid level can be measured in terms of change in capacitance. (Marks may be given for ultrasonic method or radiation method)</p>	2	4
5-e	<p>Sight glass method: Diagram:</p>		4

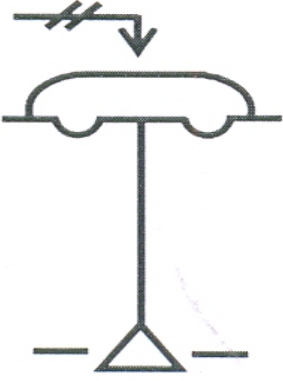

WINTER-15 EXAMINATION
Model Answer

	<p>4. Derivative (D) or Rate controller</p> $M = T_d \frac{de}{dt}$ <p>T_d – derivative time</p> <p>Reason for D controller being not used alone:</p> <p>The derivative mode cannot, by itself, control a process. One reason for this is that a constant or no deviation from the set point makes the above expression equal to zero. As well, if a sudden change in the process variable occurs, an infinite signal is sent to the controller, which causes the relevant mechanical apparatus to fully open or close. This leads to an unending instability.</p>	1½ marks	
6-b	<p>Working of air to open control valve:</p>  <p>They are control valves operated through pneumatic actuators. It is designed in such a way that if the air supply fails, the control valve will be fully closed for safety requirement of the process.</p> <p>Application: Used in situations where, the valve is used to control steam or fuel flow, the valve should be completely shut off in case of air failure.</p> <p>Working of air to close control valve:</p>	2	8

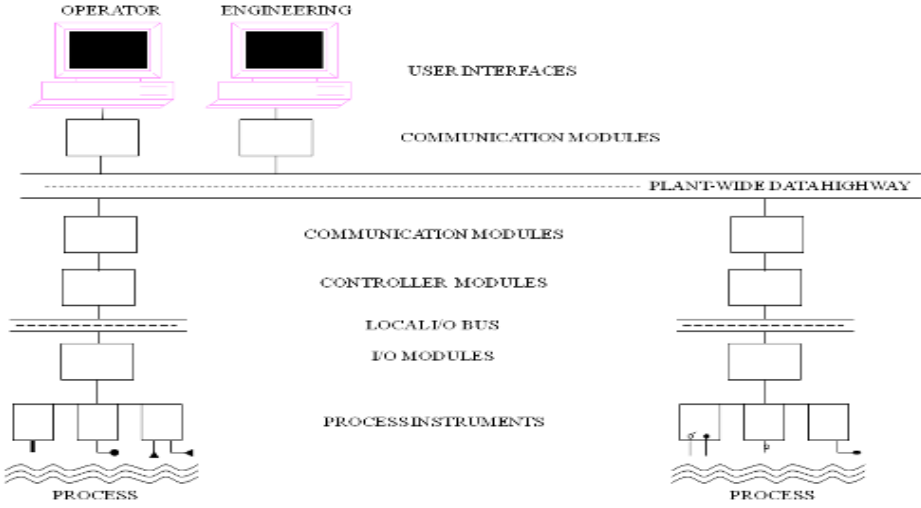

WINTER-15 EXAMINATION
Model Answer

	 <p>It is designed in such a way that if the air supply fails, the control valve will be fully open for safety requirement of the process.</p> <p>Application: Used in applications where, the valve is handling cooling water to a reactor, the flow should be maximum in case of an emergency.</p>	<p>2</p> <p>2</p>	
<p>6-c</p>	<p>Distributed control system</p>  <p>In DCS equipment is separated in functional area and is installed in different work areas of a process plant. The plant operator monitors and manipulates the set-points of the process parameter from central control room.</p> <p>Controlling portion of the DCS, distributed at various location performs following two function at each location</p>	<p>4</p> <p>4</p>	<p>8</p>



WINTER-15 EXAMINATION
Model Answer

<p>1. Measurement of analog variable and discrete inputs</p> <p>2. Generation of output signals to actuators that can change process condition</p> <p>In Figure above the operator console in the control room is connected through a data highway to several distributed system components.</p> <p>A DCS consist of the following modules:</p> <ol style="list-style-type: none">1 Operator stations that use microprocessor based CRT display and keyboard communication with control device and displays2 Remote multifunction microprocessor based controllers (PLCs)3 A digital data link (data highway) that connects the multifunction controllers with the central operator stations. <p>The first priority of DCS is to provide operator interfacing and real time process control.</p> <p>DCS has flexibility of implementation of sequential control and integration among the various types of control.</p>		
---	--	--