



**Important suggestions to examiners:**

- 1) The answers should be examined by key words and not as word-to-word as given in the model answer scheme.
- 2) The model answer and the answer written by candidate may vary but the examiner may try to assess the understanding level of the candidate.
- 3) The language errors such as grammatical, spelling errors should not be given more importance. (Not applicable for subject English and communication skills)
- 4) While assessing figures, examiner may give credit for principle components indicated in a figure. The figures drawn by candidate and model answer may vary. The examiner may give credit for any equivalent figure drawn.
- 5) Credits may be given step wise for numerical problems. In some cases, the assumed constant values may vary and there may be some difference in the candidate's answers and model answer.
- 6) In case some questions credit may be given by judgment on part of examiner of relevant answer based on candidate understands.
- 7) For programming language papers, credit may be given to any other program based on equivalent concept.

<b>Q.1 A</b>	<b>Attempt any TEN of the following :</b>	<b>20 Marks</b>
<b>a)</b>	<b>State the meaning of the term phase difference.</b>	
Ans:	<b>Phase Difference: -</b> It is defined as difference of angle between starting point of two ac sinusoidal quantities.	<b>(2 Mark)</b>
<b>b)</b>	<b>Define crest factor and form factor, state its value.</b>	
Ans:	<b>1. Crest (Peak) factor for a sinusoidal quantity:</b> It is defined as the ratio of Maximum value to the RMS value. <b>Value of Crest (Peak) factor: 1.41 (for a sinusoidal quantity)</b> <b>2. Form factor :</b> It is defined as the ratio of RMS value to the Average value of an alternating quantity <b>Value of Form factor: 1.11 (for a sinusoidal quantity)</b>	<b>( Each Definition &amp; Value: 1 Mark)</b>
<b>c)</b>	<b>Define RMS value of an electrical quantity.</b>	
Ans:	<b>(i) RMS value of an electrical Quantity :</b> The r.m.s value of an alternating current is that steady current (d.c) which when flowing through a given resistance for a given time produces the same amount of heat as produced by the alternating current when flowing through the same resistance for the same time. <b>OR</b>	<b>(2 Mark)</b>

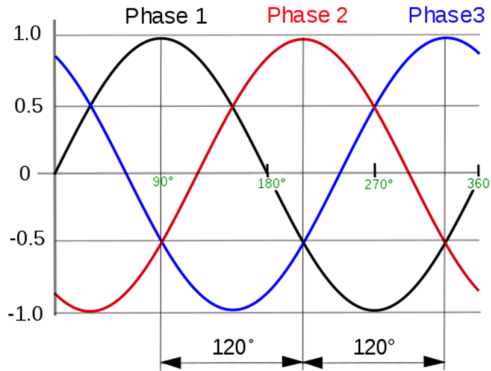

	$\therefore \text{RMS Value} = \text{Form Factor} \times \text{Average Value}$ <b>OR</b> $\text{RMS Value} = 0.707 \times \text{Maximum Value}$
<b>d)</b>	<b>State the meaning of Impedance and Impedance triangle.</b>
Ans:	<b>Impedance (Z) :-</b> (1 Mark) The total opposition (considering resistance and reactance) in the circuit is called as impedance. <b>Impedance triangle. :-</b> (1 Mark) The triangle representing all the opposition in the circuit is called as impedance triangle.
<b>e)</b>	<b>Draw the voltage waveform of a 3 phase supply with respect to time.</b>
Ans:	<b>Voltage waveform of a 3 phase supply with respect to time:</b> (2 Mark)  <p style="text-align: right;">or equivalent figure</p>
<b>f)</b>	<b>State the concept of phase sequence.</b>
Ans:	<b>Concept of Phase sequence:</b> (2 Mark) The phase sequence is defined as the order in which all the phases attain their maximum positive values.
<b>g)</b>	<b>What is meant by 3 phase balanced and unbalanced load ?</b>
Ans:	<b>1. Balanced load :</b> (1 Mark) Balanced three phase load is defined as star or delta connection of three equal impedances having equal real parts and equal imaginary parts. e.g Three impedances each having resistance of 5 ohm and inductive reactance of 15 ohm connected in star or delta. <b>2. Unbalanced load :</b> (1 Mark) In unbalanced load The respective Magnitude and phase angle currents are not



	identical in three phases. <b>OR</b> Impedances of one or more phases are different from other phases. ( $Z_1$ , $Z_2$ , & $Z_3$ are not identical simultaneously) <b>OR</b> Magnitude and phase angle of load impedance are not identical.
<b>h)</b>	<b>State Faraday's law of electromagnetic induction.</b>
Ans:	<b>First Law:</b> - Whenever change in the magnetic flux linked with a coil or conductor, an EMF is induced in it. <b>OR</b> Whenever a conductor cuts magnetic flux, an EMF is induced in conductor. <b>(1 Mark)</b> <b>Second Law:</b> - The Magnitude of induced EMF is directly proportional to (equal to) the rate of change of flux linkages. <b>(1 Mark)</b> $e = -\frac{Nd}{dt}d\phi$
<b>i)</b>	<b>State two applications of "Power transforms".</b>
Ans:	<b>Applications of "Power transforms":</b> <b>(Any Two application expected: 1 Mark each)</b> <ol style="list-style-type: none"><li>1. Low Voltage generation level.</li><li>2. Low voltage distribution</li><li>3. High voltage transmission</li><li>4. Changing voltage level during transmission</li><li>5. Producing high voltage level at generating station</li><li>6. Welding transformer</li><li>7. Heating Transformer</li></ol>
<b>j)</b>	<b>Define transformation ratio of transformer.</b>
Ans:	<b>Transformation Ratio (k):-</b> ----- <b>(2 Marks)</b> It is the ratio of secondary number of turns to primary number of turns. <b>OR</b> It is the ratio of secondary voltage to primary voltage. <b>OR</b> It is the ratio of primary current to secondary current. $\text{Transformation ratio } (k) = \frac{N_2}{N_1} \text{ or } = \frac{E_2}{E_1} \text{ or } = \frac{V_2}{V_1} \text{ or } = \frac{I_1}{I_2}$



<b>k)</b>	<b>Define (i) slip (ii) slip speed.</b>
Ans:	<b>i) Slip:-</b> ( Each Definition : 1 Mark) It is the ratio the difference between the synchronous speed and actual speed of the rotor to synchronous speed. It is expression in percentage = $\% \text{ Slip} = \frac{N_s - N}{N_s}$ <b>ii) Slip speed =</b> It is defined as the difference of synchronous speed and speed at which motor is rotating $N_s - N$ Ns= Synchronous speed Where, N= Rotor speed
<b>l)</b>	<b>Write any four applications of 3 phase slip ring induction motor.</b>
Ans:	<b>Applications of 3-Ph Slip ring induction Motor:</b> (Any Two Expected: 1 Mark each ) i) Water Pumps                      ii) Tube wells                      iii) Lathes Machine iv) Line shaft                      v) Circular-saws                      vi) Grinders vii) Polishers                      viii) Wood Planners                      ix) Compressors x) Laundry washing machines                      xi) fans                      xii) Blowers
<b>m)</b>	<b>State the types of single phase induction motor.</b>
Ans:	<b>Types of single phase induction motor:</b> (Any Two Expected: 1 Mark each ) 1. Split Phase induction Motor 2. Capacitor Start Induction Motor 3. Capacitor Start capacitor run induction Motor ( Two value capacitor method) 4. Permanent Split Capacitor (PSC) Motor 5. Shaded Pole Induction
<b>n)</b>	<b>State the types of Earthing.</b>
Ans:	<b>Types of Earthing Systems:</b> ( Any Two Types are expected: 1 Mark each ) 1. Plate Earthing 2. Pipe Earthing 3. Rod Earthing



<b>Q.2</b>	<b>Attempt any FOUR of the following :</b>	<b>16 Marks</b>																																				
a)	<b>Write any four advantages of "AC" over "DC" supply.</b>																																					
Ans:	<b>Differentiate AC supply with DC supply: ( Any Four Point Expected : 1 each)</b>																																					
	<table border="1"><thead><tr><th>S.No.</th><th>Points</th><th>AC Supply</th><th>DC Supply</th></tr></thead><tbody><tr><td>1</td><td>Amount of energy that can be carried</td><td>Safe to transfer over longer city distances and can provide more power</td><td>Voltage of DC cannot travel very far until it begins to lose energy</td></tr><tr><td>2</td><td>Cause of the direction of flow of electrons</td><td>Rotating magnet along the wire</td><td>Steady magnetism along the wire</td></tr><tr><td>3</td><td>Frequency</td><td>The frequency of alternating current is 50Hz or 60Hz depending upon the country.</td><td>The frequency of direct current is zero.</td></tr><tr><td>4</td><td>Direction</td><td>It reverses its direction while flowing in a circuit.</td><td>It flows in one direction in the circuit.</td></tr><tr><td>5</td><td>Current</td><td>It is the current of magnitude varying with time</td><td>It is the current of constant magnitude.</td></tr><tr><td>6</td><td>Flow of Electrons</td><td>Electrons keep switching directions - forward and backward.</td><td>Electrons move steadily in one direction or 'forward'.</td></tr><tr><td>7</td><td>Obtained from</td><td>A.C Generator and mains.</td><td>Cell or Battery.</td></tr><tr><td>8</td><td>Passive Parameters</td><td>Impedance.</td><td>Resistance only</td></tr></tbody></table>	S.No.	Points	AC Supply	DC Supply	1	Amount of energy that can be carried	Safe to transfer over longer city distances and can provide more power	Voltage of DC cannot travel very far until it begins to lose energy	2	Cause of the direction of flow of electrons	Rotating magnet along the wire	Steady magnetism along the wire	3	Frequency	The frequency of alternating current is 50Hz or 60Hz depending upon the country.	The frequency of direct current is zero.	4	Direction	It reverses its direction while flowing in a circuit.	It flows in one direction in the circuit.	5	Current	It is the current of magnitude varying with time	It is the current of constant magnitude.	6	Flow of Electrons	Electrons keep switching directions - forward and backward.	Electrons move steadily in one direction or 'forward'.	7	Obtained from	A.C Generator and mains.	Cell or Battery.	8	Passive Parameters	Impedance.	Resistance only	
S.No.	Points	AC Supply	DC Supply																																			
1	Amount of energy that can be carried	Safe to transfer over longer city distances and can provide more power	Voltage of DC cannot travel very far until it begins to lose energy																																			
2	Cause of the direction of flow of electrons	Rotating magnet along the wire	Steady magnetism along the wire																																			
3	Frequency	The frequency of alternating current is 50Hz or 60Hz depending upon the country.	The frequency of direct current is zero.																																			
4	Direction	It reverses its direction while flowing in a circuit.	It flows in one direction in the circuit.																																			
5	Current	It is the current of magnitude varying with time	It is the current of constant magnitude.																																			
6	Flow of Electrons	Electrons keep switching directions - forward and backward.	Electrons move steadily in one direction or 'forward'.																																			
7	Obtained from	A.C Generator and mains.	Cell or Battery.																																			
8	Passive Parameters	Impedance.	Resistance only																																			
b)	<b>Define each of the following terms : (i) Frequency (ii) Time period (iii) Amplitude (iv) Cycle</b>																																					
Ans:	<p style="text-align: right;"><b>( Each Definition: 1 Mark)</b></p> <ol style="list-style-type: none"><li><b>Frequency:</b> Number of cycles completed by an alternating quantity in one second is called 'Frequency'. <math>F = \frac{1}{t} Hz</math></li><li><b>Time Period:</b> Time period of an alternating quantity is defined as the time required for an alternating quantity to complete one cycle</li><li><b>Amplitude:</b> The maximum value of attained by alternating quantity is called amplitude</li><li><b>Cycle:</b> A complete set of variation of an alternating quantity which is repeated at regular interval of time is called as a cycle.</li></ol> <p style="text-align: center;"><b>OR</b></p> <p>Each repetition of an alternating quantity recurring at equal intervals is known as a cycle.</p>																																					



c)	<b>What is power factor ? State its significance. What is the condition for unity power factor ?</b>
Ans:	<p><b>Definition of Power factor:</b> <span style="float: right;"><b>( 1.5 Mark)</b></span></p> <p>Power factor is cosine of angle between voltage and current.</p> <p style="text-align: center;"><b>OR</b> <math>\text{Cos}\phi = R/Z</math></p> <p style="text-align: center;"><b>OR</b></p> <p>Power factor is the ratio of active power to the apparent power</p> <p style="text-align: center;"><math>P. f = KW/KVA</math></p> <p><b>Significance of Power factor: ( Any two point expected)</b> <span style="float: right;"><b>( 1.5 Mark)</b></span></p> <ol style="list-style-type: none"><li>1. P.F. increases current reduce so; cross section of conductor decreases hence its cost is reduces.</li><li>2. P.F. increases current reduce so, cross section of conductor decreases hence weight decreases. So design of supporting structure becomes lighter.</li><li>3. Copper losses Decreases, Hence transmission efficiency increases.</li><li>4. Voltage drop reduces, hence voltage regulation becomes better</li><li>5. Handling capacity (KW) of each equipment increases as p.f. increases.</li><li>6. Less capacity (KVA) rating of equipments are required so capital cost decreases.</li><li>7. Cost per unit (KWH) decreases.</li></ol> <p><b>The condition for unity power factor:</b> <span style="float: right;"><b>( 1 Mark)</b></span></p> <ul style="list-style-type: none"><li>➤ When cosine of angle between voltage and current <b>is zero.</b></li></ul> <p style="text-align: center;"><b>OR</b></p> <ul style="list-style-type: none"><li>➤ When <math>R = Z</math></li></ul> <p style="text-align: center;"><b>OR</b></p> <ul style="list-style-type: none"><li>➤ When <math>KW = KVA</math></li></ul>



d) Draw the schematic diagram of AC flowing through pure inductance. Write the expression for voltage and current. Draw phasor diagram.

Ans: Schematic diagram of AC flowing through pure inductance:

(1.5 Mark)

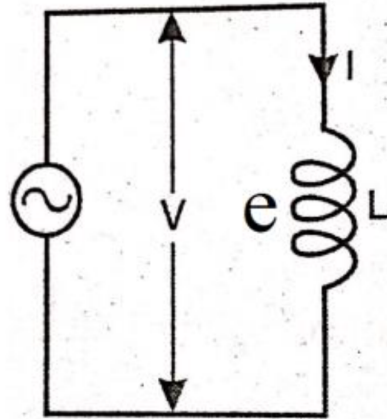

or equivalent Diagram

Pure inductance circuit Phasor Diagram : (Waveform not expected)

(1.5 Mark)

Phasor Diagram :

Waveform:

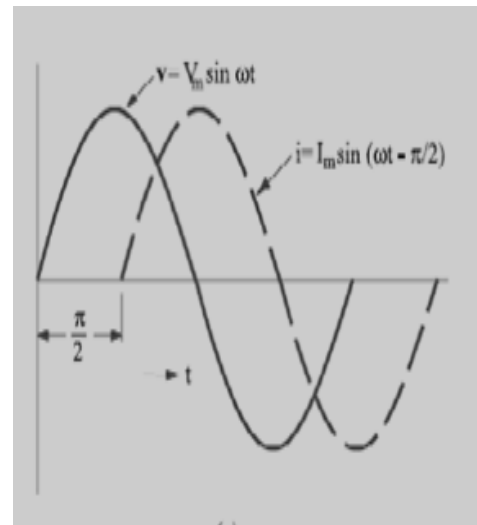
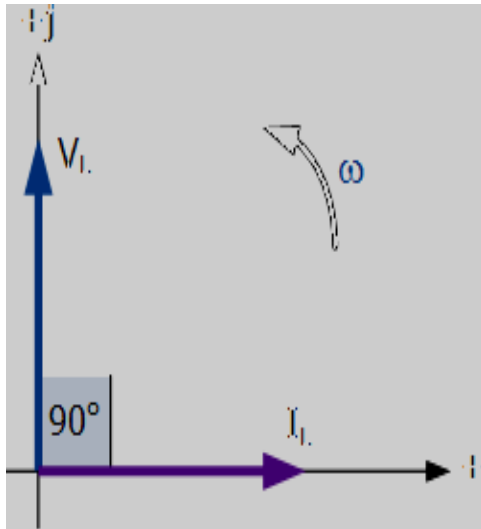

Expression for Voltage and Current:

(1 Mark)

1. Equation for voltage  $V = V_m \sin \omega t$
2. Equation for current  $I = I_m \sin (\omega t - \frac{\pi}{2})$  or  $I_m \sin (\omega t - 90^\circ)$



e)	<p><b>Draw a star connected 3 phase load and show line voltages and phase voltages on it. Also write the relation between line and phase values of voltage and current.</b></p>																
Ans:	<p><b>Diagram of star connected 3 phase load and show line voltages and phase voltages:</b></p> <p><b>Diagram of star connected circuit:</b> <span style="float: right;"><b>(2 Mark)</b></span></p> <div style="text-align: center;"> <p style="text-align: right;">or equivalent figure</p> </div> <p><b>i) The relation between line current and phase current in star connected load.</b></p> $I_L = I_{ph} \quad \text{(1 Mark)}$ <p><b>ii) The relation between line voltage and phase voltage in star connected Load</b></p> $V_L = \sqrt{3} V_{ph} \quad \text{(1 Mark)}$																
f)	<p><b>Compare Star and Delta connected system. (any four points)</b></p>																
Ans:	<p><b>Compare Star and Delta connected system:</b> <span style="float: right;"><b>( Any Four Point expected : 1 Mark each)</b></span></p> <table border="1" style="width: 100%; border-collapse: collapse;"> <thead> <tr> <th style="width: 10%;">S.No</th> <th style="width: 45%;">Star connected system</th> <th style="width: 45%;">Delta connected system</th> </tr> </thead> <tbody> <tr> <td style="text-align: center;">1</td> <td>In STAR connection, the starting or finishing ends (Similar ends) of three coils are connected together to form the neutral point. A common wire is taken out from the neutral point which is called Neutral.</td> <td>In DELTA connection, the opposite ends of three coils are connected together. In other words, the end of each coil is connected with the start of another coil, and three wires are taken out from the coil joints</td> </tr> <tr> <td style="text-align: center;">2</td> <td>There is a <b>Neutral or Star Point</b></td> <td>No Neutral Point in Delta Connection.</td> </tr> <tr> <td style="text-align: center;">3</td> <td>Three phase four wire system is derived from Star Connections (<b>3-Phase, 4 Wires System</b>) We may Also derived 3 Phase 3 Wire System from Star Connection.</td> <td>Three phase three wire system is derived from Delta Connections (<b>3-Phase, 3 Wires System</b>)</td> </tr> <tr> <td style="text-align: center;">4</td> <td>Line Current is Equal to Phase Current. i.e.</td> <td>Line Voltage is Equal to Phase Voltage. i.e. Line Voltage = Phase Voltage</td> </tr> </tbody> </table>		S.No	Star connected system	Delta connected system	1	In STAR connection, the starting or finishing ends (Similar ends) of three coils are connected together to form the neutral point. A common wire is taken out from the neutral point which is called Neutral.	In DELTA connection, the opposite ends of three coils are connected together. In other words, the end of each coil is connected with the start of another coil, and three wires are taken out from the coil joints	2	There is a <b>Neutral or Star Point</b>	No Neutral Point in Delta Connection.	3	Three phase four wire system is derived from Star Connections ( <b>3-Phase, 4 Wires System</b> ) We may Also derived 3 Phase 3 Wire System from Star Connection.	Three phase three wire system is derived from Delta Connections ( <b>3-Phase, 3 Wires System</b> )	4	Line Current is Equal to Phase Current. i.e.	Line Voltage is Equal to Phase Voltage. i.e. Line Voltage = Phase Voltage
S.No	Star connected system	Delta connected system															
1	In STAR connection, the starting or finishing ends (Similar ends) of three coils are connected together to form the neutral point. A common wire is taken out from the neutral point which is called Neutral.	In DELTA connection, the opposite ends of three coils are connected together. In other words, the end of each coil is connected with the start of another coil, and three wires are taken out from the coil joints															
2	There is a <b>Neutral or Star Point</b>	No Neutral Point in Delta Connection.															
3	Three phase four wire system is derived from Star Connections ( <b>3-Phase, 4 Wires System</b> ) We may Also derived 3 Phase 3 Wire System from Star Connection.	Three phase three wire system is derived from Delta Connections ( <b>3-Phase, 3 Wires System</b> )															
4	Line Current is Equal to Phase Current. i.e.	Line Voltage is Equal to Phase Voltage. i.e. Line Voltage = Phase Voltage															





	Line Current = Phase Current $I_L = I_{PH}$	$V_L = V_{PH}$
5	Line Voltage is $\sqrt{3}$ times of Phase Voltage. i.e. $V_L = \sqrt{3} V_{PH}$	Line Current is $\sqrt{3}$ times of Phase Current. i.e. $I_L = \sqrt{3} I_{PH}$
6	The Total Power of three phases could be found by $P = \sqrt{3} \times V_L \times I_L \times \cos\Phi$ .... Or $P = 3 \times V_{PH} \times I_{PH} \times \cos\Phi$	The Total Power of three phases could be found by $P = \sqrt{3} \times V_L \times I_L \times \cos\Phi$ ... or $P = 3 \times V_{PH} \times I_{PH} \times \cos\Phi$
7	The speeds of Star connected motors are slow as they receive $1/\sqrt{3}$ voltage.	The speeds of Delta connected motors are high because each phase gets the total of line voltage
8	In Star Connection, the phase voltage is low as $1/\sqrt{3}$ of the line voltage, so, it needs low number of turns, hence, saving in copper.	In Delta connection, The phase voltage is equal to the line voltage, hence, it needs more number of turns.
9	Low insulation required as phase voltage is low	Heavy insulation required as Phase voltage = Line Voltage.
	In Power Transmission, Star Connection system is general and typical to be used.	In Power Distribution and industries, Delta Connection is general and typical to be used.

**Q.3**      **Attempt any FOUR of the following :**      **16 Marks**

a) **Define quality factor and bandwidth of a series resonant circuit and give expression of the same.**

Ans:      **i) Quality factor-**      **(2 Mark)**

It is the voltage magnification in series circuit or ratio Of  $V_C/V$  or  $V_L/V$ .

$$Q = \frac{\omega_0}{B} = \frac{1}{R} \sqrt{\frac{L}{C}}$$

**ii) Bandwidth of a series resonant circuit:**      **(2 Mark)**

The bandwidth of the series circuit is defined as the range of frequencies in which the amplitude of the current is equal to or greater than  $(1/\sqrt{2} = \sqrt{2}/2)$  times its maximum amplitude,

$$B = \omega_2 - \omega_1 = R/L$$



b)	<b>An alternating current is represented by <math>i = 70.7 \sin 520 t</math>, determine its (i) Frequency (ii) RMS value of current (iii) Average value of current (iv) Find the current at 0.0015 sec. after passing through zero and increasing positively.</b>
Ans:	<p><b>Given data :</b></p> $i = 70.7 \sin 520 t \text{ -----}i$ <p><b>Step-I:-</b> To find max. Value of voltage &amp; current; comparing equation i &amp; ii with following equation iii &amp; iv respectively</p> $\therefore I = I_m \sin wt \text{ .....}ii$ <p>We get <math>I_m = 70.7 \text{ volt}</math></p> <p><b>Step-II:- To find frequency:</b></p> $\therefore f = \frac{\omega}{2 \times \pi} = \frac{520}{2 \times \pi} \text{ ----- (1/2 Marks)}$ $\therefore f = 82.76 \text{ Hz} \text{ ----- (1/2 Marks)}$ <p><b>Step-III:- To find RMS value of Current:</b></p> $\therefore I_{rms} = 0.707 \times V_m \text{ ----- (1/2 Marks)}$ $\therefore I_{rms} = 0.707 \times 70.7$ $\therefore I_{rms} = 50 \text{ Amp} \text{ ----- (1/2 Marks)}$ <p><b>Step-IV:- Average value of current:</b></p> $\therefore I_{avg} = 0.639 \times 70.7 \text{ ----- (1/2 Marks)}$ $\therefore I_{avg} = 45.177 \text{ Amp} \text{ ----- (1/2 Marks)}$ <p><b>Step-V:- Current at 0.0015 sec. after passing through zero and increasing positively:</b></p> $\therefore i = 70.7 \sin 520 t \frac{180}{\pi} \text{ ----- (1/2 Marks)}$ $\therefore i = 70.7 \sin 520 \times (0.0015) \frac{180}{\pi}$ $\therefore i = 70.7 \times 0.7032$ $\therefore i = 49.72 \text{ Amp} \text{ ----- (1/2 Marks)}$



c) Three impedances of  $(8 + j6)$  ohms each are connected in star to 3 phase, 440 V, 50 Hz balance a.c. supply. Calculate line voltage, phase voltage, line current, phase current, power, power factor.

Ans: **Solution:-**

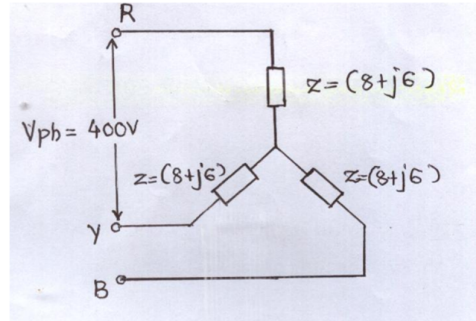

or equivalent fig

i) line voltage  $V_L = 440$  Volt

$$\text{In Star connection } V_{ph} = \frac{V_L}{\sqrt{3}}$$

ii) Phase voltage  $V_{ph} = 440$  Volt

$$V_{ph} = \frac{440}{\sqrt{3}} = 254.034 \text{ volt} \text{----- (1 Mark)}$$

iii) Phase current ( $I_{ph}$ ) ;

$$\text{Phase current } (I_{ph}) = \frac{V_{ph}}{Z_{ph}} \text{----- (1/2 Mark)}$$

$$\text{Phase current } (I_{ph}) = \frac{254.034}{(8 + j6)} = \frac{254.034}{10 \angle 36.86}$$

$$\text{Phase current } (I_{ph}) = 25.403 \angle -36.86 \text{----- (1/2 Mark)}$$

iv) Line current ( $I_{line}$ ) ;

Phase current is equal to line current :-

$$\therefore \text{Line current } (I_L) = 25.403 \angle -36.86 \text{----- (1/2 Mark)}$$

v) Power factor.

$$\therefore \text{Power factor} = \cos \phi = \cos (-36.86)$$



	<p><math>\therefore</math> Power factor = <math>\cos\phi = 0.80</math> lagging ----- (1/2 Mark)</p> <p>vi) Power:</p> $P = 3 * V_{ph} * I_{ph} * \cos\theta \quad \text{----- (1/2 Mark)}$ $P = 3 * 254.034 * 25.403 * 0.8$ $P = 15487.74 \text{ watt} \quad \text{----- (1/2 Mark)}$
d)	<b>State Fleming's Right hand rule.</b>
Ans:	<b>Fleming's Right Hand Rule:</b> ( 4 Mark) <p>Arrange three fingers of right hand mutually perpendicular to each other ,if the first figure indicates the direction of flux, thumb indicates the direction of motion of the conductor, then the middle finger will point out the direction of induced current.</p>
e)	<b>Give the classification of transformer based on construction.</b>
Ans:	<b>the Classification of transformer based on construction :</b> ( 4 Mark) <ol style="list-style-type: none"><li>1. Core type transformer</li><li>2. Shell type transformer</li><li>3. Berry type transformer</li></ol>
f)	<b>Draw the speed-torque characteristics of 3 phase induction motor and explain the same.</b>
Ans:	<b>Torque-Speed characteristics :</b> (Characteristics -2 Marks & Explanation:- 2 Mark) <p>Speed-Torque Curve for a Three-Phase Induction Motor</p> <p>or Equivalent fig</p>



	<p><b>Explanation: From the above characteristics:-</b></p> <ul style="list-style-type: none"><li>➤ When Slip (S) <math>\cong 0</math> (i.e <math>N \cong N_s</math>) torque is almost zero at no load, hence characteristics start from origin</li><li>➤ As load on motor increases Slip increases and therefore torques increases.</li><li>➤ For lower values of load, torque proportional to slip, and characteristics will having linear nature.</li><li>➤ At a particular value of Slip, maximum torque conditions will be obtained which is <math>R_2 = SX_2</math></li><li>➤ For higher values of load i.e. for higher values of slip, torque inversely proportional to slip and characteristics will having hyperbolic nature. In short breakdown occurs due to over load.</li><li>➤ The maximum torque condition can be obtained at any required slip by changing rotor resistance.</li></ul>
<b>Q.4</b>	<b>Attempt any FOUR of the following : <span style="float: right;">16 Marks</span></b>
<b>a)</b>	<b>A series R-L circuit takes a current of 2.7A when connected to 240 V, 50 Hz, ac supply and consumes 350 watts. Calculate resistance, inductance, impedance and power factor.</b>
Ans:	<p><b>Given Data:</b></p> <p>I = 2.72 A, V = 240V, f = 50 Hz, and P = 350 watt</p> <p><b>i) Power Factor :</b></p> <p><math>\therefore P = V I \cos \phi</math> ----- (1/2 Mark)</p> <p><math>\therefore \cos \phi = \frac{350}{240 \times 2.7}</math></p> <p><math>\therefore \cos \phi = 0.540 \text{ lag}</math> ----- (1/2 Mark)</p> <p><b>ii) Impedance Z :</b></p> <p><math>\therefore Z = \frac{V}{I} = \frac{240}{2.7}</math> ----- (1/2 Mark)</p> <p><math>\therefore Z = 88.88 \Omega</math> ----- (1/2 Mark)</p> <p><b>iii) Resistance R :</b></p> <p><math>\therefore \cos \phi = \frac{R}{Z} \therefore R = \cos \phi \times Z = 0.540 \times 88.88</math> ----- (1/2 Mark)</p> <p><math>\therefore R = 48 \Omega</math> ----- (1/2 Mark)</p> <p><b>iv) Inductance L :</b></p> <p><math>\therefore X_L^2 = Z^2 - R^2</math> ----- (1/2 Mark)</p>



	$\therefore X_L = \sqrt{Z^2 - R^2}$ $\therefore X_L = \sqrt{(88.88)^2 - (48)^2}$ $\therefore X_L = 74.80 \Omega$ $\therefore X_L = 2\pi FL \quad \therefore L = \frac{X_L}{2\pi F}$ $\therefore L = 0.238 H$ <p style="text-align: right;">----- (1/2 Mark)</p>
b)	<p><b>Explain the generation of alternating voltage and alternating currents with the help of suitable diagram.</b></p>
Ans:	<p><b>Generation of alternating voltage and alternating currents:</b></p> <p style="text-align: right; color: red;">(Figure -2 Marks &amp; Explanations- 2 Marks)</p> <div style="text-align: center;"> </div> <p style="text-align: right;">or equivalent figure</p> <ul style="list-style-type: none"> <li>➤ Voltage <math>V = 100 \sin \omega t</math></li> <li>➤ Current <math>i = 4 \sin (\omega t - 30^\circ)</math></li> </ul>
c)	<p><b>Explain : (i) Dynamically induced emf (ii) Statically induced emf</b></p>
Ans:	<p><b>i) Statically induced emf :</b> <span style="float: right; color: red;">( 2 Mark)</span></p> <p style="text-align: center;">In the Statically induced emf flux linkined with coil or winding changes (<math>d\Phi/dt</math>) and coil or winding is stationary such induced emf is called Statically induced emf</p> $E = - N (d\Phi/dt)$ <p><b>ii) Dynamically induced emf:</b> <span style="float: right; color: red;">( 2 Mark)</span></p> <p style="text-align: center;">If flux linking with a particular conductor is brought about by moving the coil in</p>



stationary field or by moving the magnetic field w.r.t. to stationary conductor. Then the e.m.f. induced in coil or conductor is known as “Dynamically induced e.m.f.  
$$E = B l \cdot v \cdot \sin\theta \text{ volts}$$

**d) Compare Electric and magnetic circuit on any four points.**

Ans: **Compare Electric and magnetic circuit: ( Any Four Point expected : 1 Mark each)**

S.No	Electric Circuit	Magnetic circuit
1	Path traced by the current is known as electric current.	The magnetic circuit in which magnetic flux flow
2	EMF is the driving force in the electric circuit. The unit is Volts.	MMF is the driving force in the magnetic circuit. The unit is ampere turns.
3	There is a current I in the electric circuit which is measured in amperes.	There is flux $\phi$ in the magnetic circuit which is measured in the weber.
4	The flow of electrons decides the current in conductor.	The number of magnetic lines of force decides the flux.
5	Resistance (R) oppose the flow of the current. The unit is Ohm	Reluctance (S) is opposed by magnetic path to the flux. The Unit is ampere turn/weber.
6	$R = \rho \cdot l/a$ . Directly proportional to l. Inversely proportional to a. Depends on nature of material.	$S = l/(\mu_0\mu_r a)$ . Directly proportional to l. Inversely proportional to $\mu = \mu_0\mu_r$ . Inversely proportional to a
7	The current $I = \text{EMF} / \text{Resistance}$	The Flux = MMF/ Reluctance
8	The current density	The flux density
9	Kirchhoff current law and voltage law is applicable to the electric circuit.	Kirchhoff mmf law and flux law is applicable to the magnetic flux.

**e) A 3 kVA, 230 V/115 V, 50 Hz, 10 transformer has following losses : constant loss = 100 watts, variable loss = 350 watts, Calculate full load efficiency at 0.8 p.f. lagging**

Ans: **Given Data:**

3 kVA Transformer, Constant Loss ( Iron loss) = 100 watt

Variable loss ( Copper loss) 350 watt

**Efficiency at Full Load** 
$$\eta_{FLL} = \frac{KVA \times \cos\phi}{KVA \times \cos\phi + \text{Iron losses} + \text{copper losses}} \times 100 \quad \text{-- (2 Mark)}$$

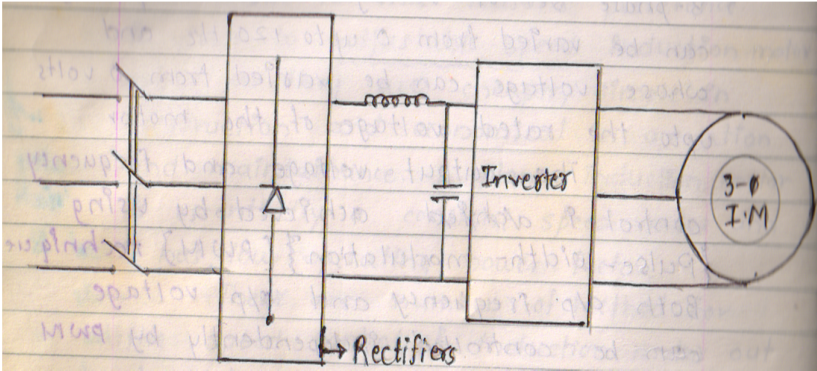

	$\eta_{FLL} = \frac{3 \times 10^3 \times 0.8}{3 \times 10^3 \times 0.8 + 100 + 350} \times 100$ $\eta_{FL} = 84.210 \% \text{ ----- (2 Mark)}$
f)	<b>Explain V/F speed control method of 3 phase induction motor.</b>
Ans:	<b>By Voltage/ frequency control (V/f) method: ( Figure : 2 Mark &amp; Explanation: 2 Mark)</b>
	
	<ul style="list-style-type: none"><li>➤ If the ratio of voltage to frequency is kept constant, the flux remains constant.</li><li>➤ The maximum torque which is independent of frequency can be maintained approximately constant.</li><li>➤ However at a low frequency, the air gap flux is reduced due to drop in the stator impedance and the voltage has to be increased to maintain the torque level.</li><li>➤ This type of control is usually known as Volts/ Hertz or V/f control.</li><li>➤ A simple circuit arrangement for obtaining variable voltage and frequency is as shown in the above figure.</li></ul>
<b>Q.5</b>	<b>Attempt any FOUR of the following : 16 Marks</b>
a)	<b>State the different types of power in A.C circuit. Write the expression and units for the same.</b>
Ans:	<b>Different types of power in A.C circuit:</b> <b>i) Active Power (P):- ( 1.5 Mark)</b> The active power is defined as the average power $P_{avg}$ taken by or consumed by the given circuit. $P = V.I.Cos\phi \quad \text{Unit: - Watt OR Kilowatt}$ <b>ii) Reactive Power (Q):- ( 1.5 Mark)</b> The reactive power is defined as the product of V, I and sine of angle between V and I i.e. $\phi$



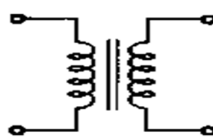
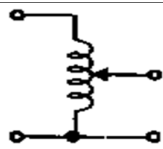
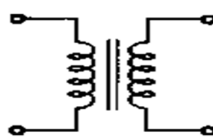
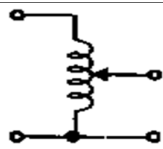
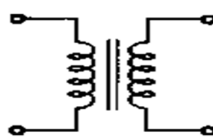
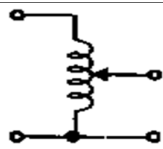

	$Q = V.I. \sin \phi$ <b>Units: - VAR OR KVAR</b>																												
	<p><b>iii) Apparent Power (S):</b> <span style="float: right;"><b>( 1 Mark)</b></span></p> <p style="text-align: center;">This is simply the product of RMS voltage and RMS current.</p> <p style="text-align: center;"><b>Unit:</b> volt-ampere (VA) or kilo-volt-ampere (kVA) or Mega-vol-ampere (MVA)</p> <p style="text-align: center;"><math>S = VI = I^2Z</math> volt-amp</p>																												
	<p><b>b) What is kVA rating of transformer ? Why transformer rating is in kVA ?</b></p>																												
Ans:	<p><b>Meaning of kVA rating of transformer:</b> <span style="float: right;"><b>( 2 Mark)</b></span></p> <ul style="list-style-type: none"> <li>➤ The amount of capacity of energy transferred is known as KVA rating of transformer.</li> <li>➤ <math>KVA \text{ Rating} = V_1 I_1 F.L \times 10^3 = V_2 I_2 F.L \times 10^3</math></li> </ul> <p><b>Reason &amp; explanation for transformer rating is in kVA</b> <span style="float: right;"><b>( 2 Mark)</b></span></p> <p style="text-align: justify;">We know that copper loss in a transformer depends on current and iron loss depends on voltage. Therefore, the total loss in a transformer depends on the volt-ampere product only and not on the phase angle between voltage and current i.e., it is independent of load power factor. For this reason, the rating of a transformer is in KVA and KW.</p>																												
	<p><b>c) Compare two winding transformer with auto transformer. (any 4 points)</b></p>																												
Ans:	<b>(Any four points expected: Each point 1 Mark)</b>																												
	<table border="1" style="width: 100%; border-collapse: collapse; text-align: center;"> <thead> <tr> <th style="width: 10%;">S.No.</th> <th style="width: 15%;">Points</th> <th style="width: 30%;">Two winding transformer</th> <th style="width: 45%;">Autotransformer</th> </tr> </thead> <tbody> <tr> <td>1.</td> <td><b>Symbol</b></td> <td></td> <td></td> </tr> <tr> <td>2.</td> <td><b>Number of windings</b></td> <td>It has two windings</td> <td>It has one winding</td> </tr> <tr> <td>3.</td> <td><b>Copper saving</b></td> <td>Copper saving is less</td> <td>Copper saving takes more as compared to two winding</td> </tr> <tr> <td>4.</td> <td><b>Size</b></td> <td>Size is large</td> <td>Size is small</td> </tr> <tr> <td>5.</td> <td><b>cost</b></td> <td>Cost is high</td> <td>Cost is low</td> </tr> <tr> <td>6.</td> <td><b>Losses in winding</b></td> <td>More losses takes place</td> <td>Less losses takes place</td> </tr> </tbody> </table>	S.No.	Points	Two winding transformer	Autotransformer	1.	<b>Symbol</b>			2.	<b>Number of windings</b>	It has two windings	It has one winding	3.	<b>Copper saving</b>	Copper saving is less	Copper saving takes more as compared to two winding	4.	<b>Size</b>	Size is large	Size is small	5.	<b>cost</b>	Cost is high	Cost is low	6.	<b>Losses in winding</b>	More losses takes place	Less losses takes place
S.No.	Points	Two winding transformer	Autotransformer																										
1.	<b>Symbol</b>																												
2.	<b>Number of windings</b>	It has two windings	It has one winding																										
3.	<b>Copper saving</b>	Copper saving is less	Copper saving takes more as compared to two winding																										
4.	<b>Size</b>	Size is large	Size is small																										
5.	<b>cost</b>	Cost is high	Cost is low																										
6.	<b>Losses in winding</b>	More losses takes place	Less losses takes place																										



7.	<b>Efficiency</b>	Efficiency is low	Efficiency is high
8.	<b>Regulation</b>	Regulation is poor	Regulation is better
9.	<b>Electrical isolation</b>	Electrical isolation is present in between primary and secondary winding	There is no electrical isolation
10.	<b>Movable contact</b>	Movable contact is not present	Movable contact is present
11.	<b>Application</b>	Mains transformer, power supply, welding, isolation transformer	Variac, starting of ac motors, dimmerstat.

**d) What will happen if transformer is connected to D.C. supply ?**

Ans: **Reason:** **(4 Marks)**

Transformer works on faradays law of electromagnetic induction where alternating flux is required as working flux of transformer.

When transformer operates on DC supply, stationary flux (Rate of change of flux linkages are zero) will be produced instead of alternating flux, so there is no induced emf in either primary or secondary winding.

**e) A 3300/200 V, 100 kVA, single phase transformer has 80 turns on secondary winding. Calculate current in both winding, flux and primary turns.**

Ans:  $V_1 = 3300\text{ V}$     $V_2 = 240\text{ V}$     $N_1 = ?$     $N_2 = 80$     $I_1 = ?$     $I_2 = ?$

**i) To Find full load Primary current  $I_1$ :-**

$$I_1 = \frac{\text{KVA} \times 10^3}{V_1 \text{ volt}} \quad \text{----- (1/2 Mark)}$$

$$I_1 = \frac{100 \times 10^3}{3300}$$

$$I_1 = 30.3030 \text{ Amp} \quad \text{----- (1/2 Mark)}$$

**ii) To Find full load Secondary  $I_2$ :**

$$I_2 = \frac{\text{KVA} \times 10^3}{V_2 \text{ volt}} \quad \text{----- (1/2 Mark)}$$



$$I_2 = \frac{100 \times 10^3}{200}$$

$$I_2 = 500 \text{ Amp} \text{ ----- (1/2 Mark)}$$

iii) Number of primary winding turns  $N_1$ :

$$\frac{V_2}{V_1} = \frac{N_2}{N_1} \text{ OR } \frac{V_1}{V_2} = \frac{N_1}{N_2} ,$$

$$N_1 = \frac{V_1}{V_2} \times N_2 \text{ ----- (1/2 Mark)}$$

$$N_1 = \frac{3300}{200} \times 80$$

$$N_1 = 1320 \text{ turns} \text{ ----- (1/2 Mark)}$$

iii) Maximum flux:

$$E_1 = 4.44 \phi_m f N_1 \text{ ----- (1/2 Mark)}$$

$$\phi_m = \frac{E_1}{4.44 \times f \times N_1}$$

$$\phi_m = \frac{3300}{4.44 \times 50 \times 1320}$$

$$\phi_m = 0.01126 \text{ Wb} \text{ ----- (1/2 Mark)}$$

f) Explain in brief the working principle of 3 phase induction motor.

Ans: Working principle of 3-phase induction motor: (Working principle :4 Mark)

- When 3-phase stator winding is energized from a 3-phase supply, a rotating magnetic field is set up in air gap which rotates round the stator at synchronous speed  $N_s (= 120 f/P)$ .
- The rotating field passes through the air gap and cuts the rotor conductors, which as yet, are stationary.
- Due to the relative speed between the rotating flux and the stationary rotor, e.m.f.s are induced in the rotor conductors.
- Since the rotor circuit is short-circuited, currents start flowing in the rotor conductors.
- The current-carrying rotor conductors are placed in the magnetic field produced by the stator.
- Consequently, mechanical force acts on the rotor conductors.

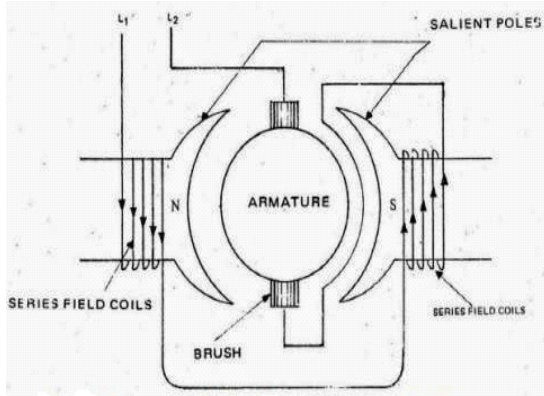
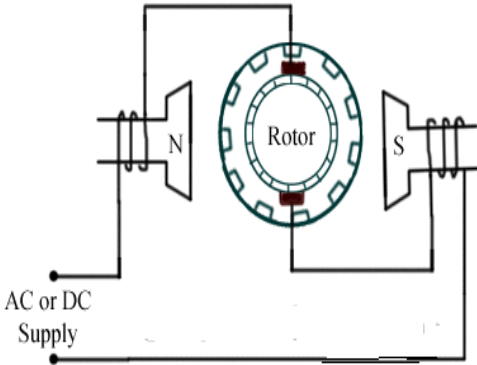

	<ul style="list-style-type: none"> <li>➤ The sum of the mechanical forces on all the rotor conductors produces a torque which tends to move the rotor.</li> <li>➤ In the same direction as the rotating field according to Lenz's law.</li> </ul>	
<b>Q.6</b>	<b>Attempt any FOUR of the following :</b>	<b>16 Marks</b>
a)	<b>Explain the necessity of starter in 3 phase induction motor.</b>	
Ans:	<p><b>Necessity of the starter in 3 phase I.M :----- (4 Mark)</b></p> <p style="text-align: center;">The current drawn by motor <math>I_a = \frac{V - E_b}{R_a}</math>, at start speed <math>N = 0</math>, <math>\therefore E_b = 0</math> and <math>I_a = \frac{V}{R_a}</math>.</p> <p>As <math>R_a</math> is very small <math>I_a</math> will be dangerously high at the time of starting. This high starting current may damage the motor armature (&amp; series field winding in the case of dc series motors). Hence to limit the starting current suitable resistance is inserted in series with armature which is called as starter. This starting resistance is cut-off in steps with increase in speed.</p>	
b)	<b>Explain with neat sketch working of universal motor.</b>	
Ans:	<p><b>Figure of Universal motor: (Figure : 2 Marks &amp; Explanation : 2 Marks)</b></p> <div style="display: flex; justify-content: space-around; align-items: center;">   </div> <p style="text-align: center;">OR</p> <p style="text-align: center;"><b>OR Equivalent figure</b></p> <p><b>Working of universal motor:</b></p> <ul style="list-style-type: none"> <li>➤ A universal motor works on either DC or single phase AC supply. When the universal motor is fed with a DC supply, it works as a DC series motor. When current flows in the field winding, it produces an electromagnetic field. The same current also flows from the armature conductors. When a current carrying conductor is placed in an electromagnetic field, it experiences a mechanical force. Due to this mechanical force, or torque, the rotor starts to rotate. The direction of this force is given by Fleming's left hand rule.</li> </ul>	



	<p>When fed with AC supply, it still produces unidirectional torque. Because, armature winding and field winding are connected in series, they are in same phase. Hence, as polarity of AC changes periodically, the direction of current in armature and field winding reverses at the same time. Thus, direction of magnetic field and the direction of armature current reverses in such a way that the direction of force experienced by armature conductors remains same. Thus, regardless of AC or DC supply, universal motor works on the same principle that DC series motor works.</p>
<b>c)</b>	<b>Why single phase motors are not self starting ? How is it made self starting ?</b>
Ans:	<p><b>Reason for single phase induction motors are not self starting: (2 Mark)</b></p> <ul style="list-style-type: none"><li>➤ When single phase AC supply is given to main winding it produces alternating flux.</li><li>➤ According to double field revolving theory, alternating flux can be represented by two opposite rotating flux of half magnitude.</li><li>➤ These oppositely rotating flux induce current in rotor &amp; there interaction produces two opposite torque hence the net torque is Zero and the rotor remains standstill.</li><li>➤ Hence Single-phase induction motor is not self starting.</li></ul> <p style="text-align: center;"><b>OR</b></p> <p><b>Single phase induction motor</b> has distributed stator winding and a squirrel-cage rotor. When fed from a single-phase supply, its stator winding produces a flux (or field) which is only alternating i.e. one which alternates along one space axis only. It is not a synchronously revolving (or rotating) flux as in the case of a two or a three phase stator winding fed from a 2 of 3 phase supply. Now, alternating or pulsating flux acting on a stationary squirrel-cage rotor cannot produce rotation (only a revolving flux can produce rotation). <b>That is why a single phase motor is not self-starting.</b></p> <p><b>Reason for made self starting: (2 Marks)</b></p> <p>The single phase induction motors are not self starting because the produced stator flux is alternating in nature and at the starting the two components of this flux cancel each other and hence there is no net torque.</p> <p>The solution to this problem is that if the stator flux is made rotating type, rather than alternating type, which rotates in one particular direction only. Then the <u>induction motor</u> will become self starting. Now for producing this rotating <u>magnetic field</u> we require two alternating flux, having some phase difference angle between them. When these two fluxes interact with each other they will produce a resultant flux. This resultant flux is rotating in nature and rotates in space in one particular direction only. Once the motor starts running, the additional flux can be removed. The motor will continue to run under the influence of the main flux only.</p>



d) Draw neat sketch and write working principle of shaded pole 1-ph motor

Ans: i) Shaded Pole Induction Motor : (Figure-2 Mark & Explanation: 2 Mark)

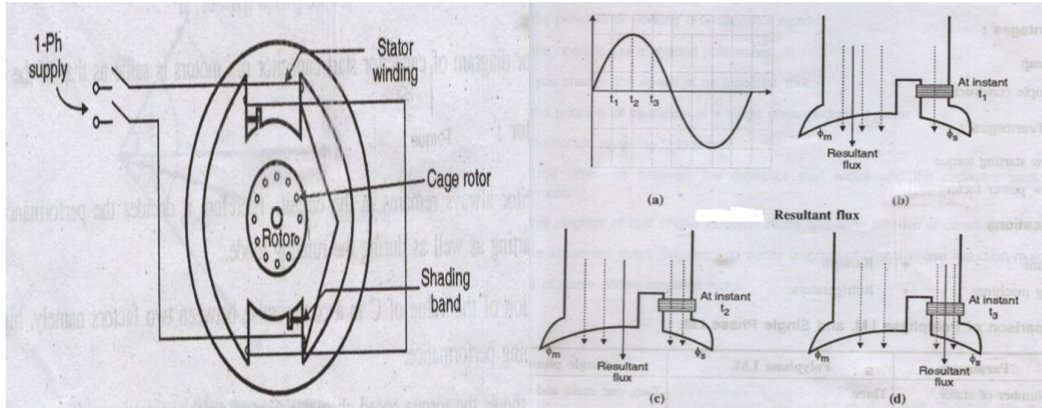

or

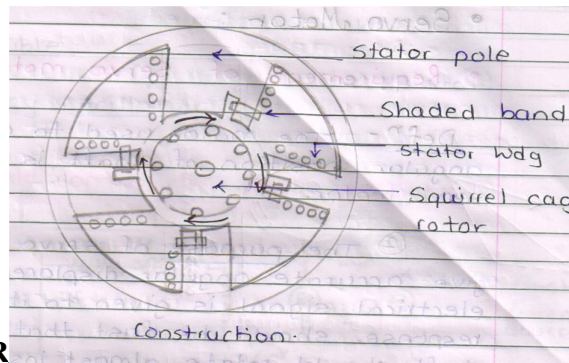

OR

Equivalent Fig.

**Construction & Working:-**

When single phase supply is applied across the stator winding an alternating field is created. The flux distribution is non uniform due to shading coils on the poles.

Now consider three different instants of time  $t_1, t_2, t_3$  of the flux wave to examine the effect of shading coil as shown in the fig above. The magnetic neutral axis shifts from left to right in every half cycle, from non shaded area of pole to the shaded area of the pole. This gives to some extent a rotating field effect which may be sufficient to provide starting torque to squirrel cage rotor.

e) Define : (i) Minimum fusing current (ii) fusing factor

Ans: (i) Minimum fusing current: (2 Marks)

It is minimum current (RMS) at which the fuse element will melt.

(ii) fusing factor: (2 Marks)

$$\text{Fusing Factor} = \frac{\text{Minimum fusing current}}{\text{Rated Current}}$$

Fusing Factor always greater than current.



f)	<b>Write any four safety precautions while working with electrical system.</b>
Ans:	<p><b>The Following are the safety precautions while working with electrical system:-</b> <b>(Any Four point expected : 1 Mark Each point)</b></p> <ol style="list-style-type: none"><li>1. Avoid working on live parts.</li><li>2. Switch off the supply before starting the work.</li><li>3. Never touch a wire till you are sure that no currents are flowing.</li><li>4. Do not guess, whether electric current is flowing through a circuit by touching.</li><li>5. Insulate yourself on the insulating material like wood, plastic etc. before starting the work on live main.</li><li>6. Your hand &amp; feet must be dry (not wet) while working on live main.</li><li>7. Rubber mats must be placed in front of electrical switch board/ panel.</li><li>8. Use hand gloves, Safety devices &amp; proper insulated tools.</li><li>9. Ground all machine tools, body, and structure of equipments.</li><li>10. Earthing should be checked frequently.</li><li>11. Do not use aluminum ladders but use wooden ladders.</li><li>12. Do not operate the switches without knowledge.</li><li>13. Use proper insulated tools &amp; safety devices.</li><li>14. When working on live equipment obey proper instruction.</li><li>15. Do not work on defective equipment.</li><li>16. Use safe clothing.</li><li>17. Use shoes with rubber soles to avoid shock.</li><li>18. Do not wear suspected Necklace, arm bands, finger ring, key chain, and watch with metal parts while working.</li><li>19. Do not use defective material. Do not work if there is improper illumination such as in sufficient light or unsuitable location producing glare or shadows.</li><li>20. Do not work if there is an unfavorable condition such as rain fall, fog or high wind.</li><li>21. Do not sacrifice safety rules for speed.</li><li>22. Do not allotted work to untrained person (worker) to handle electrical equipment.</li><li>23. Make habit to look out for danger notice, caution board, flags, and tags.</li><li>24. Warn others when they seen to be in danger near live conductors or apparatus.</li><li>25. Inspect all electrical equipment &amp; devices to ensure there is no damage or exposed wires that may causes a fire or shock.</li><li>26. Avoid using electrical equipment near wet, damp areas.</li><li>27. Use approved discharge earth rod for before working.</li><li>28. Never speak to any person working upon live mains.</li><li>29. Do not Do the work if you are not sure or knowledge of the condition of equipment/ machine.</li><li>30. Safety book/ Training should be given to all persons working in plants.</li></ol>