



WINTER – 14 EXAMINATION

Model Answer

Subject Code: **17317**

Important Instructions to examiners:

- 1) The answers should be examined by key words and not as word-to-word as given in the model answer scheme.
- 2) The model answer and the answer written by candidate may vary but the examiner may try to assess the understanding level of the candidate.
- 3) The language errors such as grammatical, spelling errors should not be given more Importance (Not applicable for subject English and Communication Skills).
- 4) While assessing figures, examiner may give credit for principal components indicated in the figure. The figures drawn by candidate and model answer may vary. The examiner may give credit for any equivalent figure drawn.
- 5) Credits may be given step wise for numerical problems. In some cases, the assumed constant values may vary and there may be some difference in the candidate's answers and model answer.
- 6) In case of some questions credit may be given by judgement on part of examiner of relevant answer based on candidate's understanding.
- 7) For programming language papers, credit may be given to any other program based on equivalent concept.



1. Attempt any FIVE of the following:

20M

a. Define the following terms

- | | |
|-----------------|-------------------|
| (i) Accuracy | (iii) Sensitivity |
| (ii) Precession | (iv) Resolution |

Ans a. **Each Definition- 1M**

Accuracy: The degree of closeness with which an instrument approaches the true value of the quantity being measured is known as accuracy.

Precision: The measure of the degree to which successive measurement differs from each other is known as precision.

Sensitivity: The ratio of change in output of an instrument to the change in input is known as sensitivity.

$$\text{Sensitivity} = \frac{\text{Change in output}}{\text{Change in input}}$$

Resolution: The smallest change in input to which instrument can respond is known as resolution.

b. Define calibration. Explain why calibration is needed for measuring instrument.

Ans b.

Calibration:

2M

The process of deriving the value of a quantity by comparing that quantity with a standard quantity is called as calibration.

Calibration of instrument is done to obtain correct unknown value of each scale reading on measuring instrument.

Need of calibration

2M

There are 3 main reasons for having instrument calibration:

1. To ensure reading from an instrument are consistent with other measurements.
2. To determine the accuracy of the instrument reading.
3. To establish the reliability of the instrument i.e. it can be trusted.

c. Give the two advantages and two disadvantages of PMMC instrument.

Ans c.

Advantages of PMMC meter: (Any two)

2M

1. It has uniform scale.
2. Power consumption is low
3. It can be obtained in wide ranges.
4. High sensitivity & accuracy
5. It is unaffected by external magnetic field.
6. Additional damping device not required.
7. Hysteresis problem is not there.



Disadvantages of PMMC meter: (Any two)

2M

1. It is suitable for d.c. measurement only.
2. Comparatively high cost than moving iron type instrument.
3. Ageing of permanent magnet & spring introduce errors.
4. Friction due to jewel- pivot suspension.

d. Compare analog and digital meter on the basis of

- | | |
|-----------------|--------------------------|
| (i) Display | (iii) Function available |
| (ii) Resolution | (iv) Power consumption |

Ans d. **Each Function- 1M**

Sr.No	Functions	Analog Multimeter	Digital
1	Display	Analog pointer is used	LCD display is used.
2	Resolution	Low resolution	High resolution
3	Functions available	Current, resistance, voltage measurement possible	Current, voltage, resistance, h_{fe} measurement possible
4	Power consumption	More power required	Less power required.

e. List any four applications of CRO.

Ans e. **Any four applications of CRO- 4M**

Applications of CRO:

1. It is used in laboratory for measurement of AC/DC voltage, current, frequency, phase and study nature of waveform.
2. It is used in TV receiver for creation of images.
3. It is used in radar receiver for giving visual indication of target such as aeroplane, ship etc.
4. It is used to test AF circuit for different distortion.
5. It is used to check faulty component.
6. It is used to check signals at radio and TV receiver.
7. It is used to check B-H curve of different ferromagnetic material.
8. It is used in medical equipment such as ECG, patient monitor.
9. It is used to check modulation percentage of modulated wave.
10. It is also used to check radiation pattern generated by antenna.

f. List any four specification of function generator.

Ans f. **Any four specifications- 4M**

Specifications of function generator:

1. Frequency range: 0.01 Hz-1 MHz. over 5 decades.
2. Signal generation: sine, square & saw tooth waveforms.
3. Amplitude(sine wave): 0 to 30V (rms)
4. Amplitude (square wave output): 0-30V (peak)

5. Square wave symmetry : 30% to 70%
6. Output impedance: $2k\Omega$
7. DC output: $\pm 15V$
8. Power required: 7W
9. Accuracy : $\pm 3\%$

g. Explain the concept of time domain and frequency domain.

Ans g. **Time Domain- 2M, Frequency Domain- 2M**

- In general we observe electrical signals in amplitude versus time format where time is on X- axis and amplitude is on Y- axis, this is known as time domain.
- Example: CRO.

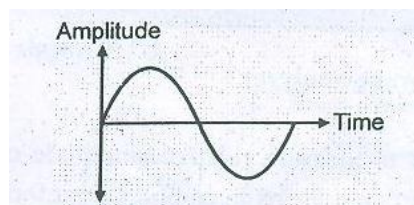

Fig: Waveform observed on CRO

- We know that during long distance communication signal get distorted. The main advantage of time domain analysis is that we cannot differentiate the complex frequency signals or distorted signal.
- To overcome disadvantage of time domain, we observed the signal in amplitude versus frequency format is known as frequency domain.
- In frequency domain the complex frequency signal can be plotted as separate spectrum for each frequency so it becomes easy to analyze the information present in the signal.
- Example: Spectrum analyzer.

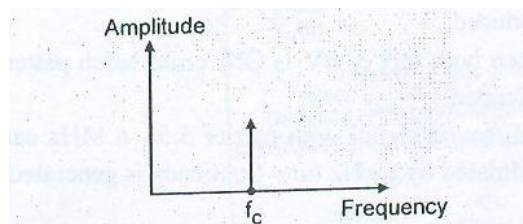

Fig: Waveform of Spectrum analyzer.

2. Attempt any FOUR of the following:

16M

a. Draw and explain working principle of Shunt resistance ammeter.

Ans a. **Circuit Diagram- 2M, Working Principle – 2M**

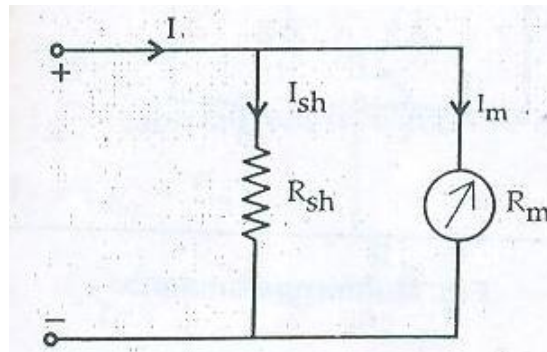

- The basic movement of dc ammeter circuit consists of D' Arsonval galvanometer.
- The coil winding of basic movement is small and light therefore it carries very small current.
- When large current is to be measured then some extra modification is required.
- For measurement of large current by using same movement a shunt resistor is connected as shown in circuit.
- The value of shunt resistor is very small so that most of the current pass through it and only small current allow to pass through the coil.

b. Draw and explain block diagram of Digital frequency meter (DFM).

Ans b. **Block Diagram- 2M, Explanation- 2M**

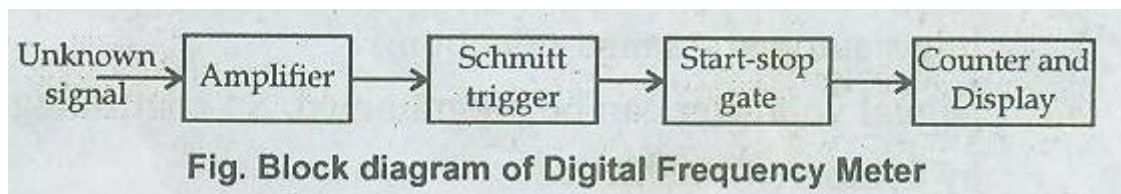

Digital frequency meter:

- Frequency is defined as number of cycles per unit time interval. The signal whose frequency is to be measured is used as an event.
- The unknown frequency is first converted to train of pulses. One pulse represents one cycle of unknown signal. These pulses are directly proportional to the frequency to be measured.

Amplifier:

- The signal whose frequency is to be measured is first amplified. The output of amplifier is applied to the Schmitt trigger.



Schmitt trigger:

- The Schmitt trigger converts the signal into square wave having fast rise and fall times.
- The square wave is then differentiated and clipped. Each pulse is proportional to each cycle of unknown signal.

Start- Stop gate:

- The output from Schmitt trigger is applied to start and stop gate. These pulses are applied to the switch.
- This switch is controlled by a signal having definite time interval. The main gate switch is closed for known time interval.
- When the gate is open, input pulses are allowed to pass through it. A counter will now start to count these pulses.
- When the gate is closed, input pulses are not allowed to pass through the gate. The counter will now stop counting.

Counter and display:

- The number of pulses during the period gate is open are counted by the counter.
- If this interval between start and stop condition is known, the frequency of unknown signal is measured.

$$F = N/t$$

Where,

F= Unknown frequency

N= Number of counts displayed by the counter.

t= Time interval between start and stop condition of the gate.

- c. Design a multi range DC ammeter using a basic movement with an internal resistance $R_m = 50\Omega$ and full scale deflection current $I_m = 1\text{mA}$. The range required are 0-10 mA, 0-50 mA, 0-100 mA, 0-500mA.

Ans c.

Given= $R_m = 50\Omega$

$I_m = 1\text{mA}$ Consider

$I_1 = 10\text{mA}$, $I_2 = 50\text{mA}$, $I_3 = 100\text{mA}$, $I_4 = 500\text{mA}$

$R_{sh1} = ?$, $R_{sh2} = ?$ $R_{sh3} = ?$ $R_{sh4} = ?$

i) $m_1 = I_1 / I_m = 10 \text{ mA} / 1\text{mA} = 10$
 $R_{sh1} = R_m / m_1 - 1 = 50 / 10 - 1 = 50/9 = 5.55\Omega$

ii) $m_2 = I_2 / I_m = 50 \text{ mA} / 1\text{mA} = 50$
 $R_{sh2} = R_m / m_2 - 1 = 50 / 50 - 1 = 50/49 = 1.02\Omega$



iii) $m_3 = I_3 / I_m = 100 \text{ mA} / 1 \text{ mA} = 100$
 $R_{sh3} = R_m / (m_3 - 1) = 50 / (100 - 1) = 50 / 99 = 0.505 \Omega$

iv) $m_4 = I_4 / I_m = 500 \text{ mA} / 1 \text{ mA} = 500$
 $R_{sh4} = R_m / (m_4 - 1) = 50 / (500 - 1) = 50 / 499 = 0.100 \Omega$

Therefore,

$R_{sh1} = 5.55 \Omega$ 1M

$R_{sh2} = 1.02 \Omega$ 1M

$R_{sh3} = 0.505 \Omega$ 1M

$R_{sh4} = 0.100 \Omega$ 1M

d. State how DMM can be used as for continuity test. Which section decides resolution in DMM.

Ans d. 4M

- To measure continuity set meter resistance mode then connect positive and negative terminal of multimeter at respectively points to which continuity is to measure.
- If meter shows zero very minimum resistance, it means there is continuity between two points.
- But if meter shows more resistance value then there is no continuity.
- A/D converter & BCD counter will decide the resolution of DMM depends upon current flowing through it.

e. Compare between single trace CRO and dual trace CRO.

Ans e. Any correct 4 points- 4M

Sr. No	Single Trace CRO	Dual Trace CRO
1	It displays only one waveform	It displays two waveforms simultaneously.
2	Only one channel is present	Two channels are present
3	Signals can be displayed continuously.	Signals can be displayed alternatively on two channels
4	Comparison of signals is not possible	Comparison of two signals are possible.
5	No need of electronic switch	It requires electronic switch to toggle.

f. Draw block diagram of logic analyzer. Give any two application of logic analyzer.

Ans f. **Block Diagram- 2M; 2 applications: 2M**

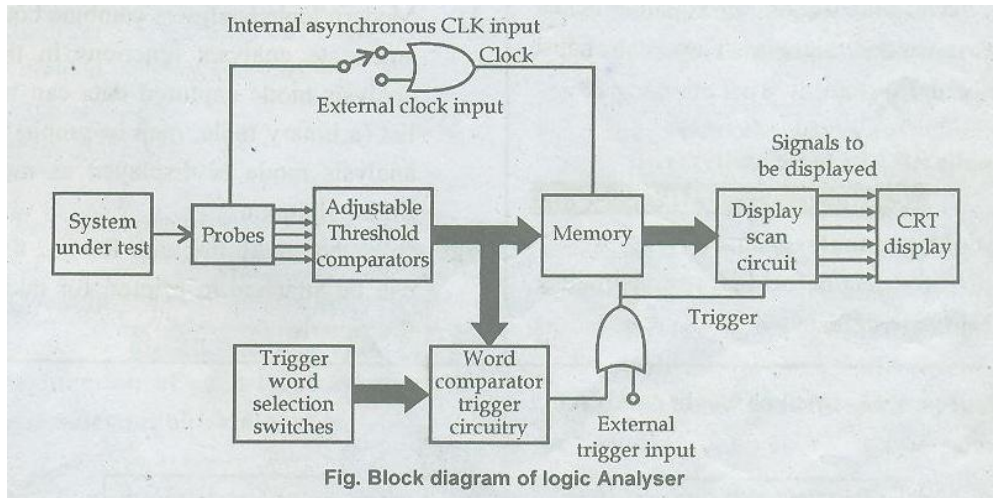

Applications of logic analyzer are: (any two)

1. Testing the IC's to detect defect before constructed.
2. To find out hardware defect.
3. VLSI chip design industries.
4. IN various software industries.
5. To find fault in Bio- medical instruments.

3. Attempt any FOUR of the following:

16M

a. Draw the neat block diagram of pulse generator. List any four specification of pulse generator.

Ans a. **Block Diagram- 2M; Any 4 specifications- 2M**

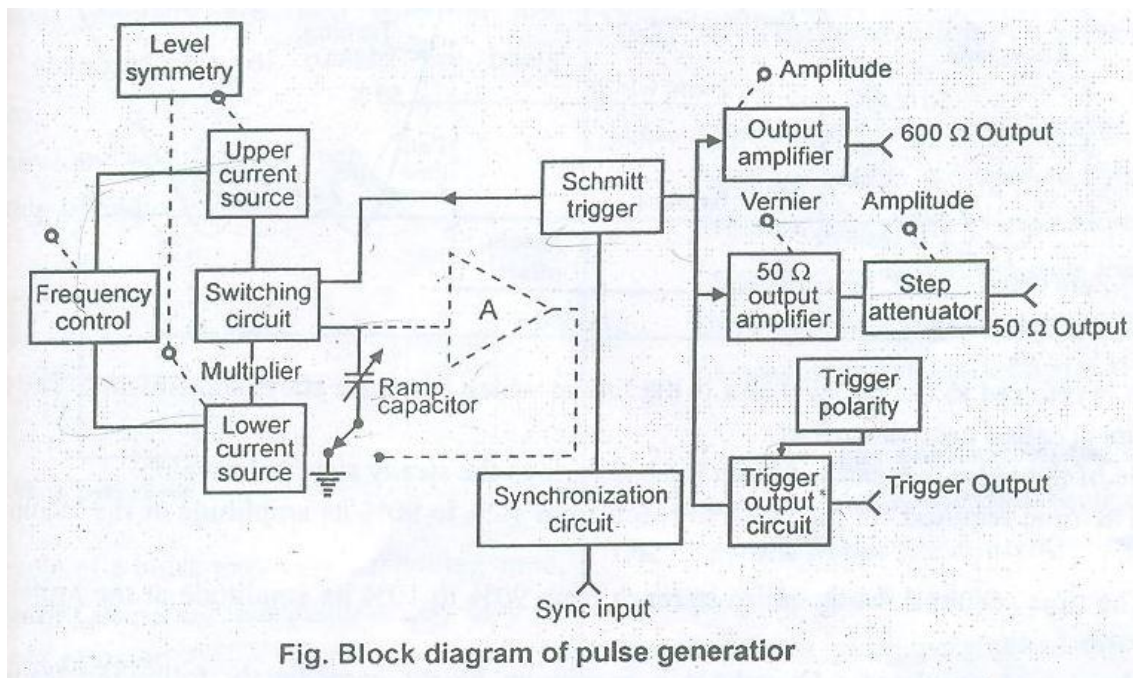

The specifications of pulse generator are as follows:

1. Frequency range: 1Hz to 10MHz.
 2. Duty cycle variation: 25% to 75 %
 3. Two independent outputs are available.
 4. a. Source supplying pulses with 5n sec rise and fall times at 5V peak amplitude.
b . Source supplying pulses with 70 n sec rise and fall times at 30 V peak amplitude.
- It can be synchronized with external signal.

To synchronize with external circuits, trigger output pulses are available. The generator can be operated as free running generator.

- b. Draw the circuit of time base generator of single trace CRO. Describe its working.

Ans b. **Circuit- 2M; Working: 2M**

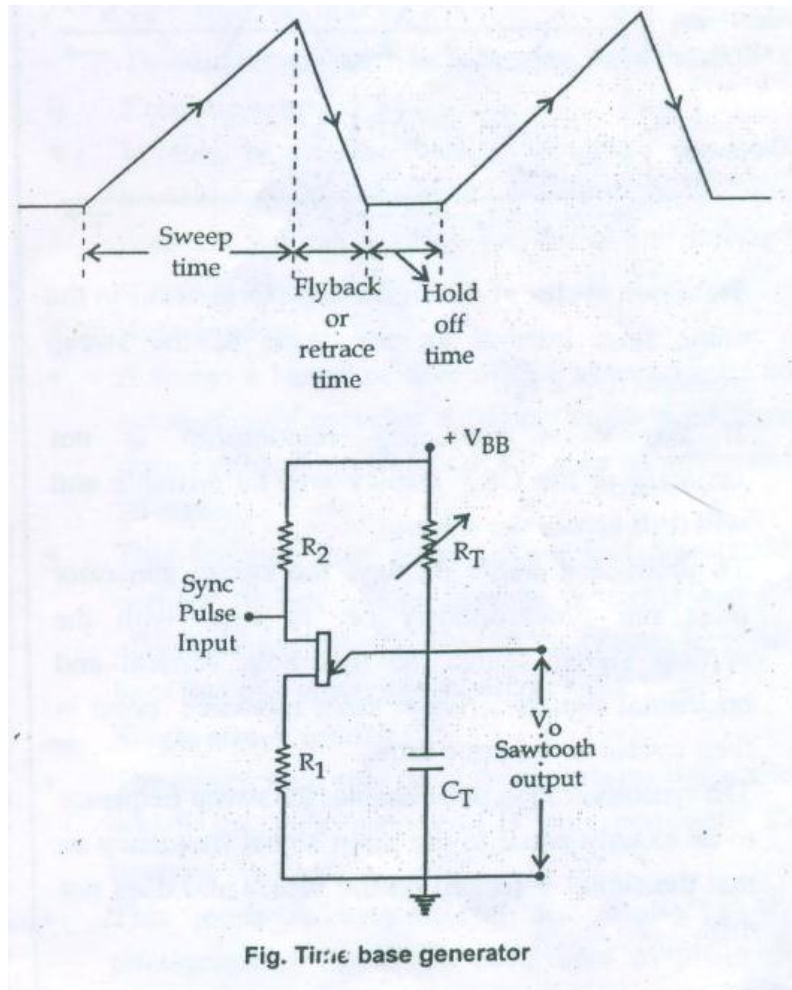

Fig. Time base generator

Time base generator:

- The main purpose of time base generator is to convert given input signal into sawtooth waveform, which will deflect the beam in the horizontal direction.
- It has two modes i.e. sweep mode and fly back mode.
- During sweep time T_S the beam moves left to right across the CRT.

- The beam is deflected towards right by increasing amplitude of ramp voltage and the fact that positive voltage attracts the negative electrons.
- During retrace time or fly back time T_r the beam returns quickly to the left side of screen.
- The control grid is generally gated OFF which black out the beam during retrace time and prevent an undesirable retrace pattern from appearing on the screen.

c. Explain the method of Q measurement with its block diagram.

Ans c. **Block Diagram- 2M; Explanation- 2M**

- Depending on measurements, the appropriate switches can be selected.
- The lower channel gives direct voltage at detector (generally calibrated in terms of Q) which can be then converted to digital signals and then displayed on digital panel meter.
- Along with basic circuit of measurement, the digital LCR-Q meter also incorporates auto zeroing, auto ranging and other facilities like indication of Low/ High battery and auto power off circuitry.

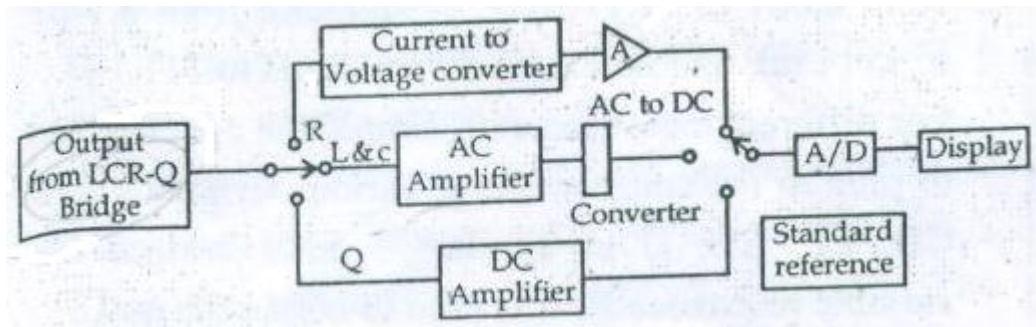

Fig: Q measurement

- The voltmeter is directly calibrated in terms of Q. However, there is an error. The measured value of Q is the Q of whole circuit and not the coil.
- These errors caused because of the shunt resistance and due to distributed capacitance.

$$Q = \frac{\omega L}{R}$$

$$Q_{measured} = \frac{\omega L}{R + R_{sh}}$$

$$\frac{Q_{actual}}{Q_{measured}} = \frac{\frac{\omega L}{R}}{\frac{\omega L}{R} + R_{sh}} = \frac{R + R_{sh}}{R}$$

$$\frac{Q_{actual}}{Q_{measured}} = 1 + \frac{R_{sh}}{R}$$

$$\text{Therefore, } Q_{measured} = Q_{actual} = 1 + \frac{R_{sh}}{R}$$

d. Draw and explain operation of Electronic AC voltmeter (Average Responding)

Ans d. **Circuit Diagram: 2M; Explain operation: 2M**

The construction of Average responding A.C. voltmeter is shown below:

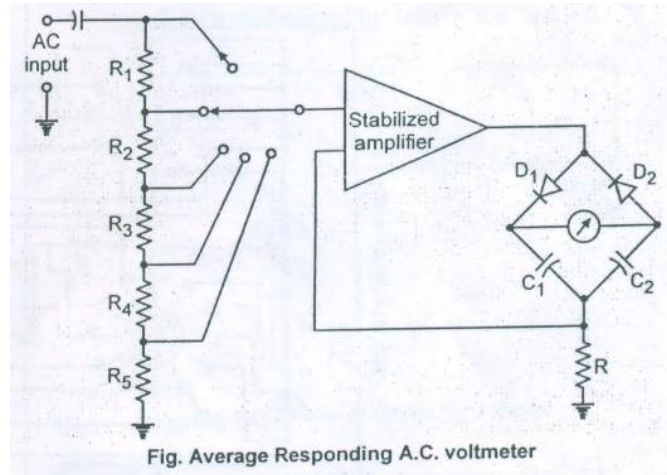

Here high stabilized amplifier is used to provide the amplification.

- The one terminal of stabilized amplifier is connected to the attenuator network which consists of five resistors. The other terminal is connected with feedback path.
- Capacitor is used to block d.c entering into stabilized non –linearity problem created by diodes. Also the variation in impedance meter is compensated by negative feedback.
- The D.C. milliammeter is calibrated in terms.
- The average reading is obtained by filtering the signal coming gives from the rectifier. Thus for meter movement gives response to average value.

e. Define the term standard. State types of standard.

Ans e. **Definition: 2M; Types of standard: 2M**

- The physical representation of a unit of measurement is called standard.
- A known accurate measure of physical quantity is termed as standard.
- These standards are used to determine the value of other physical quantity by comparison method.

• **Classifications:-**

1) International standards:

- International standards are fixed and develop by international agreement.
- These standards are maintained at International Bureau of Weights and Measures in France.
This standard gives different unit having best accuracy.
- To preserve best accuracy these standards are periodically check by absolute measurement.
- These standards are used to calibrate primary standard only.
- These are not available to ordinary user for measurement.



2) Primary standards

- These standards are preserved and maintained by National Standard Laboratories which are located at different part of the world.
E.g.-NBS (National Bureau of Standards) located at Washington.
These standards are periodically calibrated by International standards.

3) Secondary standards

- These standards are also called as basic standards.
- These standards are used by industries and calibration laboratories.
- Each industry has its own laboratory.

4) Working standards

- These standards are used in general laboratories.
- These standards are used to check components and calibrating laboratory instruments to achieve good accuracy and better performance.

f. Define the term:

- Sensitivity of voltmeter
- Load effect of voltmeter

Ans f.

i) Sensitivity of voltmeter: (2M)

The sensitivity of voltmeter means the response given by a voltmeter to input signal.

It is the ratio of total resistance (RT) to the voltage range

$$S = RT / V$$

Where, RT – Total resistance..... $RT = R_S + R_m$

V= Voltage range.

OR

It is also defined as the reciprocal of full scale deflection current of the basic movement.

$$S = 1 / I_{fsd}$$

I_{fsd} = full scale deflection current.

Loading effect of voltmeter: (2M)

Sensitivity of meter plays an important role while selecting a voltmeter.

A low sensitivity meter gives accurate reading when it is used for the measurement of voltage in low resistance circuit, but it may give inaccurate reading during the measurement of voltage in high resistance circuit.

If voltmeter connects across low resistance, then most of the current will pass through low resistance and very less current flow through voltmeter because of its high resistance. The voltage drop is a measure of true value.

If the voltmeter is connected across high resistance then the current may be divided into two paths and voltage drop recorded by meter is lower than true value. This effect is known as loading effect.



4 . Attempt any FOUR of the following:

16M

a. Define the relationship between deflecting torque (T_d) and controlling Torque (T_c)

Ans a. **Deflecting torque (T_d)- 2M and controlling Torque (T_c)-2M**

- A torque which deflects the pointer from its zero position is known as deflecting torque.
- The deflection of pointer is directly proportional to quantity to be measured.
- The deflection torque produced due to current flowing through coil.
- Let the length of coil L meter and width of coil be 'd' meter. Assume, I is the current flowing through coil having N turns. B is considering as flux density produced in air gap.
- Therefore the force exerted by coil is

$$F = BiL$$

The deflecting torque is given by

$$T_d = \text{Force} \times \text{distance}$$

$$T_d = F \times S$$

$$= B \times l \times I \times N \times d \text{ ----- 1}$$

$$T_d = B \times A \times I \times N \text{ ----- 2}$$

Controlling Torque Equation:

The controlling torque is given by

$$T_c = \Theta \times C \text{ ----- 3}$$

where,

Θ = angle of deflection

C = Deflecting constant of spring.

At equilibrium the controlling torque becomes equal to deflecting torque.

$$T_d = T_c$$

$$B \times A \times I \times N = \Theta \times C \text{ ----- 4}$$

Here, B, A, N, C are constant, therefore

$$\Theta \propto i \text{ ----- 5}$$

b. With neat sketch explain working principle of PMMC.

Ans b.

2M

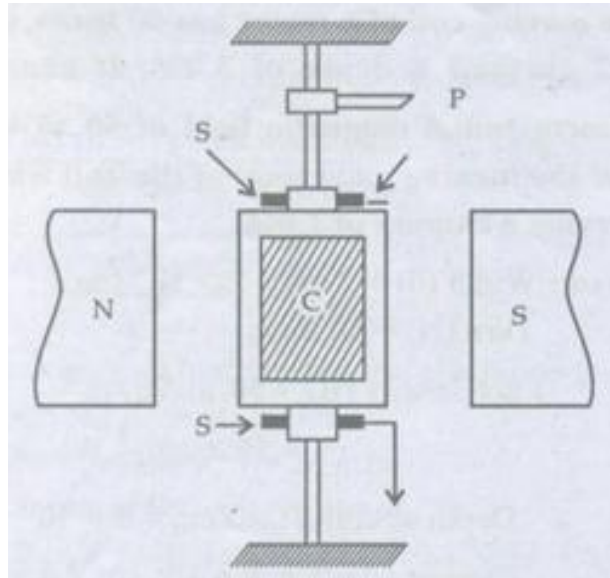

Fig: PMMC Instrument

Working:

2M

When current passes through the coil a deflecting torque is produced. This deflecting torque is produced due to interaction between magnetic field produced by permanent magnet and magnetic field produced by moving coil.

Due to this torque the coil deflects and this deflection is proportional to the current flowing through the coil. The pointer attached to the coil indicated the magnitude of quantity being measured.

The another torque is developed by the hair spring known as controlling torque. This torque helps to stabilize the pointer.

The pointer becomes stable at equilibrium; this is possible only when the controlling torque becomes equal to the deflecting torque.

c. State any four application of logic analyzer.

Ans. **Any Four points of logic analyzer- 4 M**

Applications of logic analyzer are:

1. Testing the IC's to detect defect before constructed.
2. To find out hardware defect.
3. VLSI chip design industries
4. In various software industries.
5. To find fault in Bio- medical instruments.

d. Draw a neat labelled diagram of CRT.

Ans d. **Correct diagram of CRT – 4M**

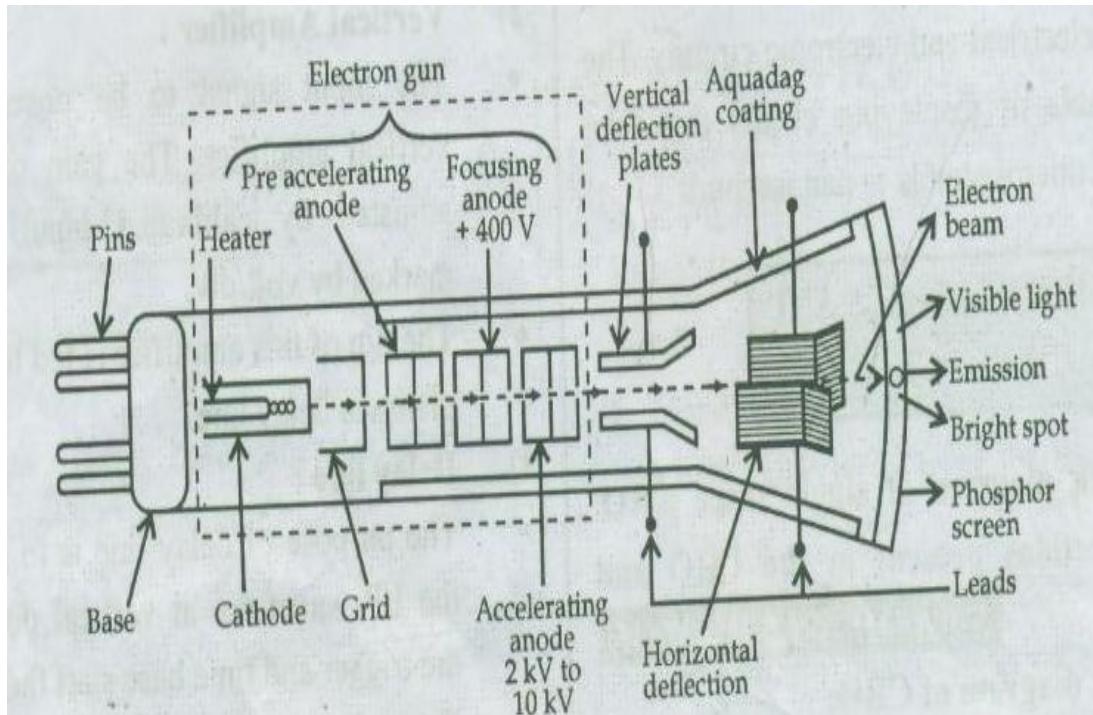

Diagram of CRT

e. Draw the circuit diagram of rectifier type AC voltmeter and explain

Ans e. **Circuit Diagram: 2M; Explanation: 2M**

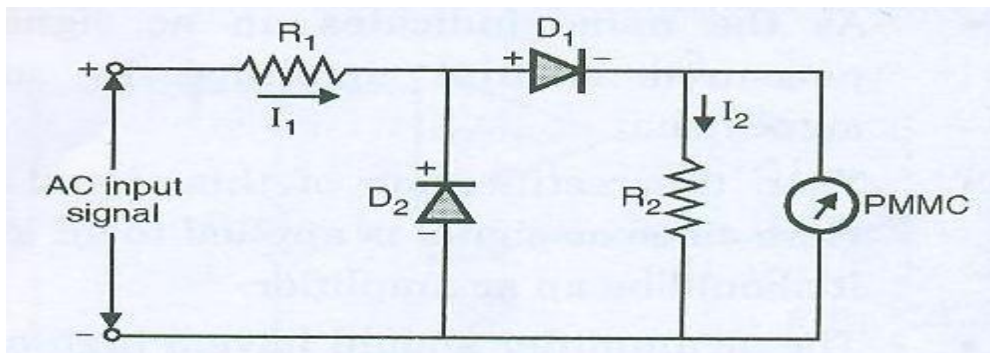

Fig: Circuit Diagram of rectifier type AC voltmeter

- Basic rectifier type AC voltmeter is a general rectifier type of voltmeter. In this case for the rectification action two diodes namely D_1 and D_2 are used.
- An a.c input signal to be measured is applied.
- If a current passing through the diode is small then there is a non-linearity problem. But for higher current the diode shows linearity. So to increase the current passing through diode; a resistance R_2 is connected in parallel with the meter.
- Now during positive half cycle of input signal, diode D_1 is forward biased with the polarities.
- While the diode D_2 is reversed biased. So during this cycle the current passes through diode D_1 and the meter. Thus the meter shows deflection.

- During the negative half cycle diode D₁ is reversed biased and diode D₂ is forward biased. So the current flows in opposite direction. In this case the meter is bypassed.
- Because of the diode action an a.c input signal is converted into pulsating dc. Thus the meter shows **average value** of an input signal.

f. What is grounding? Why it is provided?

Ans f. **What is grounding- 2M, Why it is provided- 2M**

- Grounding: - Electricity always tries to find a low resistance path to the ground. The route electricity takes it's called its path to ground. Grounding refers to the connection of parts of a wiring installation to a common earth connection. Generally grounding is used to avoid fire and shock.
- A fire incidence occurs when current leaks from a broken live wire or connection & reaches a point of zero voltage by some path other than the normal one. Such a path offers low resistance, so the high current can generate enough heat to start a fire.
- If an exposed live wire touched the metal frame of an undergrounded piece of electrical equipments the voltage of the live wire would charge the metal frame, if a person then touches the metal frame then he could suffer a serious shock.
- When the current starts from a positive terminal, it moves through the load and ends up at zero potential.
- One end of earth terminal is connected to instrument and the other end is grounded. Therefore any leakage of current is grounded by low impedance path. Any person who is touching the instrument gets protected from getting a shock.

5. Attempt any FOUR of the following:

16M

a. Draw block diagram of digital multimeter. State function of each block.

Ans a. **Diagram**

(2M)

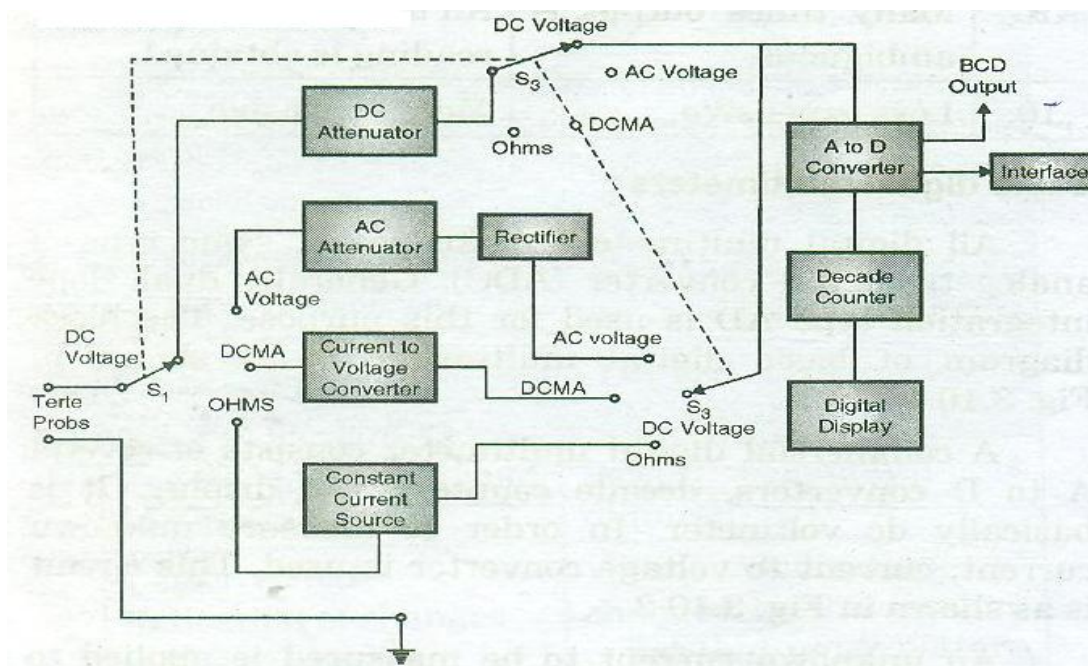

Working-

(2M)

An unknown current to be measured is applied to one of the input terminals of op-amp. Let this input is. Since an input impedance of op-amp is very high; very small current can pass through it. This current passing into the op-amp can be neglected.

$$\text{Thus, } I_{in} = I_{fb}$$

Here I_{fb} = Feedback current.

This feedback current is allowed to pass through one of the known resistances. This current will cause a voltage drop across the resistance. This voltage is applied to analog to digital converter and finally digital display is obtained. Thus output displayed on the digital display is directly proportional to unknown current.

In order to measure an unknown resistance; a constant current source is used. The current from this constant current source is allowed to pass through unknown resistance. Thus the proportional voltage is obtained. The output display is directly proportional to unknown resistance.

To measure the ac voltage; a rectifier and filter is used. This rectifier converts ac signal into dc signal. Now this dc signal is applied to A to D converter and to the digital display. The BCD output can be obtained from A to D converter. Similarly the output from digital multimeter can be used to interface with other equipments.

b. Draw neat labeled diagram of CRO.

Ans b. Neat Labeled diagram of CRO- 4M

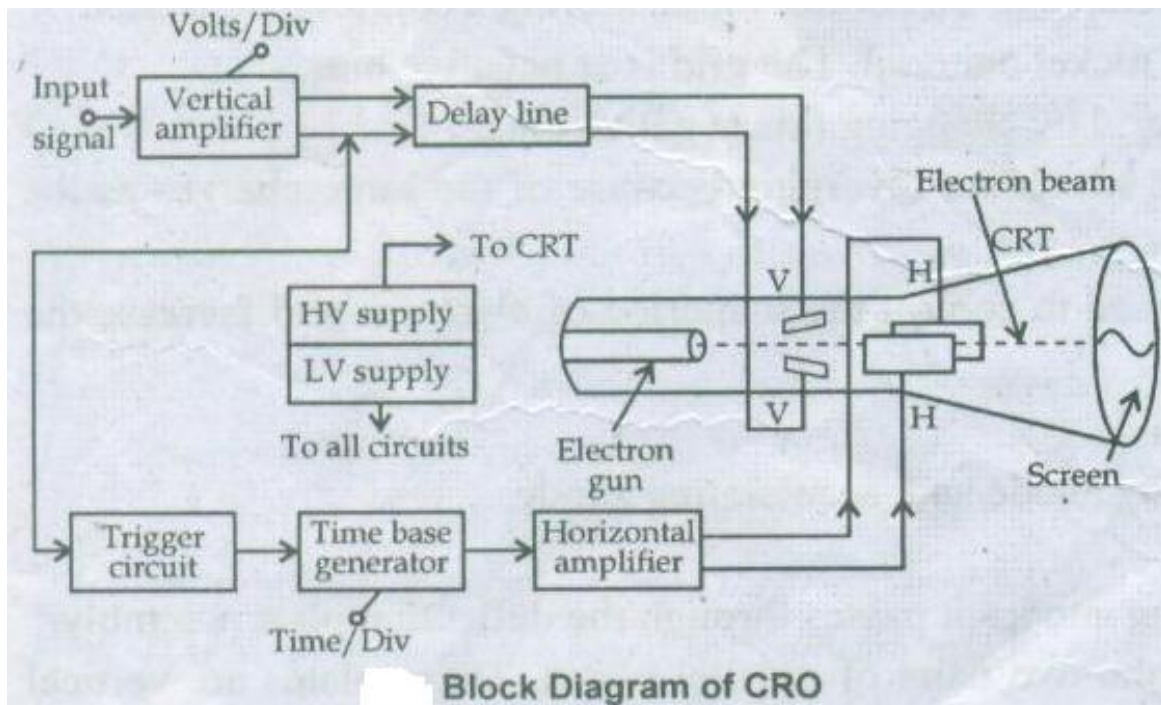

Fig. block diagram of CRO

c. Sketch block diagram of RF signal generator. Which type of signal can be generated from RF generator?

Ans c. **Block Diagram-**

2M

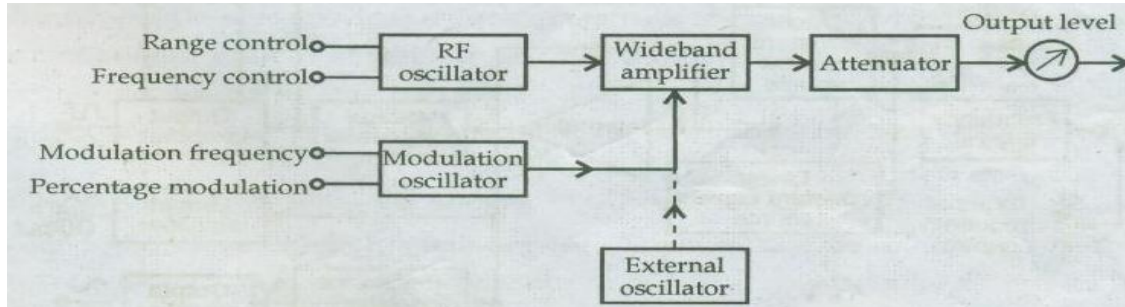

Fig: Block diagram of RF signal generator

Radio Frequency signals can be generated from RF Generator.

2M

d. State types of CRO probe. How current probe operates.

Ans d. **Types of CRO probe: 2M; How current probe operates: 2M**

1. Passive probes
2. Active probes
3. High voltage probes
4. Current probes
5. Differential probes

Current Probes:

- To make the oscilloscope more versatile as a bench instrument along with AC/DC measurement of voltages, it should also be able to measure current.
- This current must be converted to voltage before applying to vertical input.
- If DC current is passed to some semiconductors, and if the magnetic field is applied perpendicular to crystal (i.e. path of electrons), then there will be generation of the voltage across the dimensions of the crystal.
- These voltages are proportional to the applied currents levels.
- This effect was observed by Hall and hence the name hall Effect and the sensors are referred as Hall effect sensors.
- Figure shows the Hall effect sensor and feedback amplifier, include in Hall effect probe.

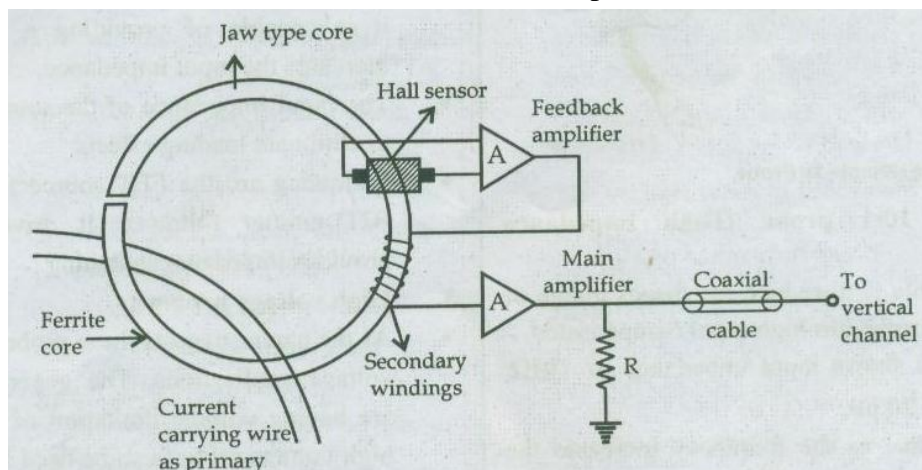

Fig: Current probe

e. Calculate the value of the multiplier resistance on the 50V range of a dc voltmeter that uses a $200\mu\text{A}$ meter movement with an internal resistance of 100Ω .

Ans e.

4M

Given: $I_{\text{fsd}} = I_m = 200 \mu\text{A} = 200 \times 10^{-6} \text{ A}$

$$R_m = 100\Omega$$

$$V = 50\text{V}$$

Solution:

$$\begin{aligned} R_{S1} &= V / I_{\text{fsd}} - R_m \\ &= (50 / 200 \times 10^{-6}) - 100 \\ &= 250000 - 100 \\ &= 249900 \\ &= 249 \times 10^3 \Omega \end{aligned}$$

$$\mathbf{R_{S1} = 249 \text{ k}\Omega}$$

f. Draw block diagram of DSO. State function of each block.

Ans f. **Block diagram- 2M; Function of each block- 2M**

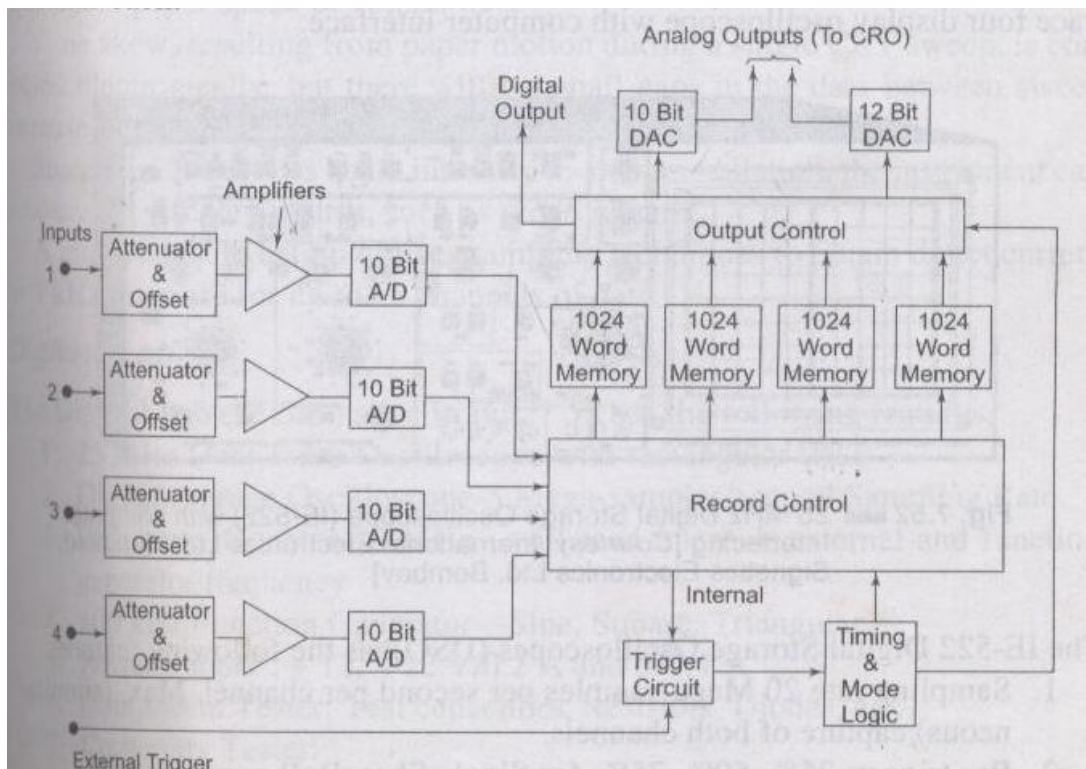

Fig. Block diagram of Digital Storage Oscilloscope



The analog voltage input signal is digitized in a 10 bit A/D converter with a resolution of 0.1% (1 part in 1024) and frequency response of 25 kHz. The total digital memory storage capacity is 4096 for a single channel, 2048 for two channels each and 1024 for four channels each.

The analog input voltage is sampled at adjustable rates (Upto 100, 000 samples per second) and data points are read onto the memory. A maximum of 4096 points are storable in this particular instrument. (Sampling rate and memory size are selected to suit the duration and waveform of the physical event being recorded.)

Once the sample record of the vent is captured in memory, many useful manipulations are possible, since memory can be read out without being erased.

If the memory is read out rapidly and repetitively, an input event which was a single shot transient becomes a repetitive or continuous waveform that can be observed easily on an ordinary scope (without going through DAC) to say a computer where a stored program can manipulate the data in almost anyway desired.

Pre triggering recording allows the input signal preceding the trigger points to be recorded. In ordinary triggering the recording process is started by the rise of the input (or some external triggering) above some preset threshold value.

As in digital recorder, DSO can be set to record continuously (new data coming into the memory pushes out the old data, once memory is full), until the trigger signal is received; then the recording is stopped, thus freezing data received prior to the trigger signal in the memory.

An adjustable trigger delay allows operator control of the stop point, so that the trigger may occur near the beginning, middle or end of the stored information

6. Attempt any FOUR of the following:

16M

- a. List out any four specification of function generator.

Ans a. **Any four specifications- 4M**

Specification of function generator.

10. Frequency range: 0.01 Hz-1 MHz. over 5 decades.
11. Signal generation: sine, square & saw tooth waveforms.
12. Amplitude (sine wave): 0 to 30V (rms)
13. Amplitude (square wave output): 0-30V (peak)
14. Square wave symmetry : 30% to 70%
15. Output impedance: 2k Ω
16. DC output: \pm 15V
17. Power required: 7W
18. Accuracy : \pm 3%

b. With neat diagram explain horizontal amplifier in CRO.

Ans b. **Diagram: 2M; Explanation: 2M**

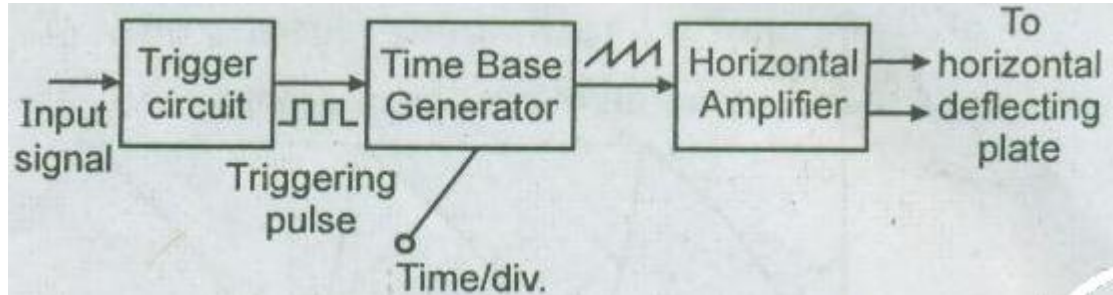

Fig: Horizontal Deflecting Circuit

- The sawtooth waveform from the time base generator is fed to the horizontal amplifier.
- This amplifier includes phase inverter and produces two simultaneous o/p waveform, a positive going and negative going saw tooth.
- Its working is similar to that of vertical amplifier. It is required to increase the amplitude of the signals generated in the sweep generator to a level which is required by horizontal deflection plates of the CRT.
- This amplifier is basically a push pull amplifier. It performs two operations. First, when oscilloscope is used in ordinary mode of operation, the horizontal amplifier simply amplify the sweep generator output. Second, in X-Y mode it can amplify the signal applied to horizontal input.

c. Write four specifications of DMM.

Ans c. **Any four specifications of DMM- 4M**

Specifications of DMM are as follows:

1. D.C. Voltage:

- Voltage range from ± 20 V to ± 1000 V
- Accuracy about $\pm 0.03\%$
- Resolution is about 10μ V

2. AC Voltage:

- Voltage range from 200mV to 750 V
- Accuracy is frequency dependent.
- Resolution: 10μ V

3. Resistance:

- Resistance range from 200Ω to $20M\Omega$
- accuracy: $\pm 0.1\%$ of reading

4. D.C. Current:

- Current range from $\pm 200\mu\text{A}$ to 2 A.
- Accuracy $\pm 0.3\%$ of reading
- Resolution $\pm 0.01\mu\text{A}$

5. A.C. Current:

- Range from $200\mu\text{A}$ to 2A
- Accuracy depends on frequency.

d. Draw and state how the Ayrton shunt type D.C. ammeter operates.

Ans d. **Diagram- 2M; Operation-2M**

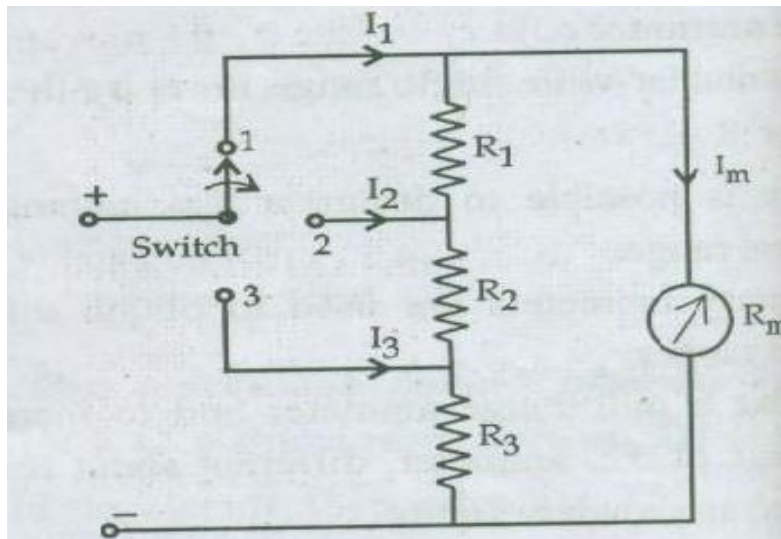

- In this shunt, different resistors are connected in series as shown in circuit.
- A variable switch is used to connect supply to terminal 1,2 &3.
- Let the current passing through meter is I_m and I_1, I_2, I_3 are different ranges.
- The equation for different position of switch is as follows.

Position 1=

- When switch (s) is at position 1, the resistors R_1, R_2 and R_3 is in series. This series combination of resistor is in parallel with meter resistance R_m .

Therefore, $(I_1 - I_m) (R_1 + R_2 + R_3) = I_m \cdot R_m$ ----- (1)

Position 2=

- When switch (s) is at position 2, the combination of R_2 and R_3 parallel with combination of R_1 and R_m .

Therefore, $(I_2 - I_m) (R_2 + R_3) = I_m (R_1 + R_m)$ ----- (2)

Position 3=

When switch (s) is at position 3, the resistance R_3 is in parallel with combination of R_1 , R_2 and R_m .

$$(I_3 - I_m) R_3 = I_m (R_1 + R_2 + R_m) \text{----- (3)}$$

By solving equation 1,2, and 3 the values of unknown shunt resistors can be calculated.

e. What is loading effect in multi range voltmeter?

Ans e.

4M

- Sensitivity of meter plays an important role while selecting a voltmeter.
- A low sensitivity meter gives accurate reading when it is used for the measurement of voltage in low resistance circuit, but it may give inaccurate reading during the measurement of voltage in high resistance circuit.
- If voltmeter is connected across low resistance, then most of the current will pass through low resistance and very less current flow through voltmeter because of its high resistance. The voltage drop is a measure of true value.
- If the voltmeter is connected across high resistance then the current may be divided into two paths and voltage drop recorded by meter is lower than true value. This effect is known as loading effect.
- Sensitivity of meter plays an important role while selecting a voltmeter.
- A low sensitivity meter gives accurate reading when it is used for the measurement of voltage in low resistance circuit, the measurement of voltage in high resistance circuit.
- If voltmeter is connected across low resistance, then most of the current will pass through low resistance and very less current flow through voltmeter because of its high resistance. The voltage drop is a measure of true value.

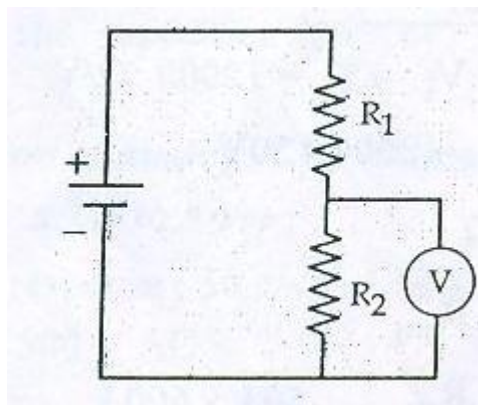

- If the voltmeter is connected across high resistance then the current may be divided into two path and voltage recorded by meter is lower than true value. This effect is known as loading effect.



f. List any eight specification of CRO.

Ans f. **Any Eight specification of CRO- 4M**

Specifications of CRO are as follows:

1. Vertical Sensitivity:

- Vertical sensitivity
- Variable Control

2. Input Impedance

3. Maximum Input

4. Coupling

5. Accuracy

6. Bandwidth

7. Time Base:

- Rise Time
- Speeds
- Variable Control

8. Trigger:

- Source: INT

EXT

Line

- Coupling: AC

TV Line/ TV Frame

9. Level

10. Mode: Auto

Normal