

MGM's
Jawaharlal Nehru Engineering College

Laboratory Manual

TDCM

For

Second Year (EEP) Students

Manual made by

Prof. P.PKOTHAVADE

FORWARD

It is my great pleasure to present this laboratory manual for second year EEP engineering students for the subject of Transformer and DC Machine. Keeping in view the vast coverage required for visualization of concepts of Electrical Machines and Transformer with simple language.

As a student, many of you may be wondering with some of the questions in your mind regarding the subject and exactly what has been tried is to answer through this manual.

Faculty members are also advised that covering these aspects in initial stage itself, will greatly relived them in future as much of the load will be taken care by the enthusiasm energies of the students once they are conceptually clear.

H.O.D.

LABORATORY MANNUAL CONTENTS

This manual is intended for the second year students of Electrical, Electronics & power engineering branch in the subject of Electrical Technology. This manual typically contains practical/Lab Sessions related electrical machine covering various aspects related the subject to enhance understanding.

Although, as per the syllabus, only descriptive treatment is prescribed, we have made the efforts to cover various aspects of electrical machine subject covering types of different electrical machines, their operating principals, their characteristics and Applications will be complete in itself to make it meaningful, elaborative understandable concepts and conceptual visualization.

Students are advised to thoroughly go through this manual rather than only topics mentioned in the syllabus as practical aspects are the key to understanding and conceptual visualization of theoretical aspects covered in the books.

Good Luck for your Enjoyable Laboratory Sessions

Prof. P.P.KOTHAVADE

SUBJECT INDEX

1. Do's and Don'ts

2. Lab exercise:

- 1) To plot magnetization characteristics of d. c. generator.
- 2) To study load characteristics of d. c. compound generator.
- 3) To study speed control of d. c. shunt motor.
- 4) Load test on DC shunt motor.
- 5) To study the three ph transformer connections.
- 6) To study d. c. motor Starter.
- 7) Polarity test and ratio test on three phase transformer.
- 8) Parallel operation of single ph. Transformer.

3. Quiz on the subject

4. Conduction of Viva-Voce Examination

5. Evaluation and Marking Systems

DOs and DON'T DOs in Laboratory:

1. Understand the equipment to be tested and apparatus to be used.
 2. Select proper type (i.e. A. c. or D. C.) and range of meters.
 3. Do not touch the live terminals.
 4. Use suitable wires (type and size).
 5. All the connection should be tight.
1. Do not leave loose wires (i.e. wires not connected).
 2. Get the connection checked before switching 'ON' the supply.
 3. Never exceed the permissible values of current, voltage, and / or speed of any machine, apparatus, wire, load, etc.
 4. Switch ON or OFF the load gradually and not suddenly.
 5. Strictly observe the instructions given by the teacher/Lab Instructor

Instruction for Laboratory Teachers:

1. Submission related to whatever lab work has been completed should be done during the next lab session. The immediate arrangements for printouts related to submission on the day of practical assignments.
2. Students should be taught for taking the observations /readings of different measuring instruments under the able observation of lab teacher.
3. The promptness of submission should be encouraged by way of marking and evaluation patterns that will benefit the sincere students.

2. Lab Exercises:

[Purpose of this exercise is to introduce the students to different D. C. and Transformer.]

Exercise No1: (2 Hours) - 1 Practical

Magnetization characteristics of a d. c. generator.

AIM: To find magnetization characteristics of a d. c. generator.

APPARATUS:

- 1) D.C. machine with a coupled prime mover
- 2) Rheostat (300 / 1.7) ----- 1 no.
- 3) D.C. Ammeter (0-1A) ----- 1 no
- 4) D.C. voltmeter (0-300v) ----- 1 no

THEORY:

1. What is residual magnetism?
2. What is O.C.C.?
3. How voltage is developed in self excited D. C. generators?

PROCEDURE:

- 1) Connect as shown in ckt. Dia.
- 2) Set the potential divider to zero output i.e. at max. Resistance position.
- 3) Run the generator with the help of its prime mover at rated speed.
- 4) Note the reading of voltmeter connected across armature terminals of the generator.
- 5) Switch on D.C. Supply to the field winding and pass a small current by changing the setting of the potential divider. Note the field current & generated voltage. Increase the field current in steps and note corresponding armature voltage.
- 6) Plot armature voltage versus the field current.

OSERVATION TABLE:

Speed of the generator = _____ r.p.m.

Sr. No.	Field current reading to be taken in increasing order of field current I_f amps	Armature voltage E volts V_a
1.	0	
2.		
3.		
4.		
5.		

GRAPH:

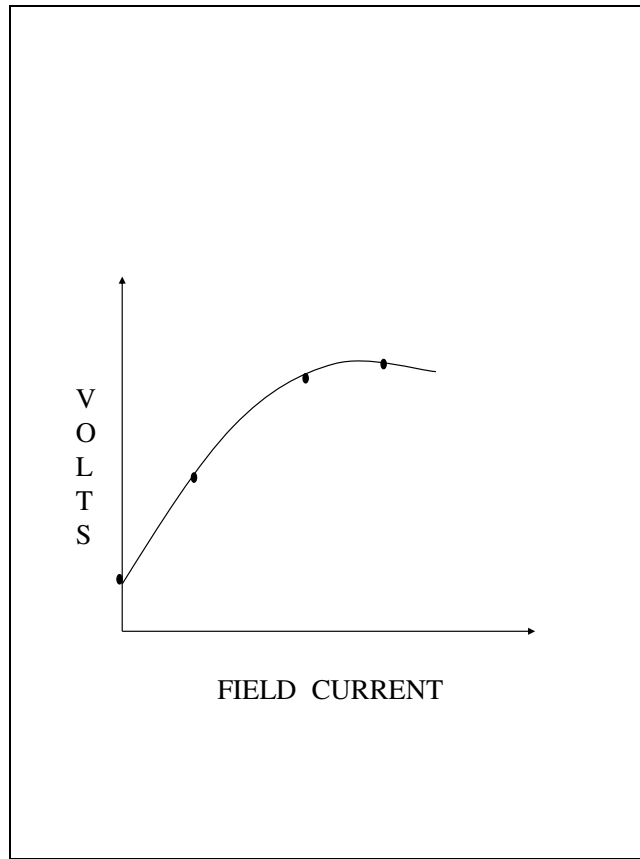

CONCLUSION:

Because of the residual magnetism the curve doesn't start from zero volts. During the starting portion of the curve, the induced voltage rises linearly with magnetic current. After saturation of poles curve loses its linearity between induced voltage and magnetic current.

MAGNETISATION CHARACTERISTICS OF D C GENERATOR

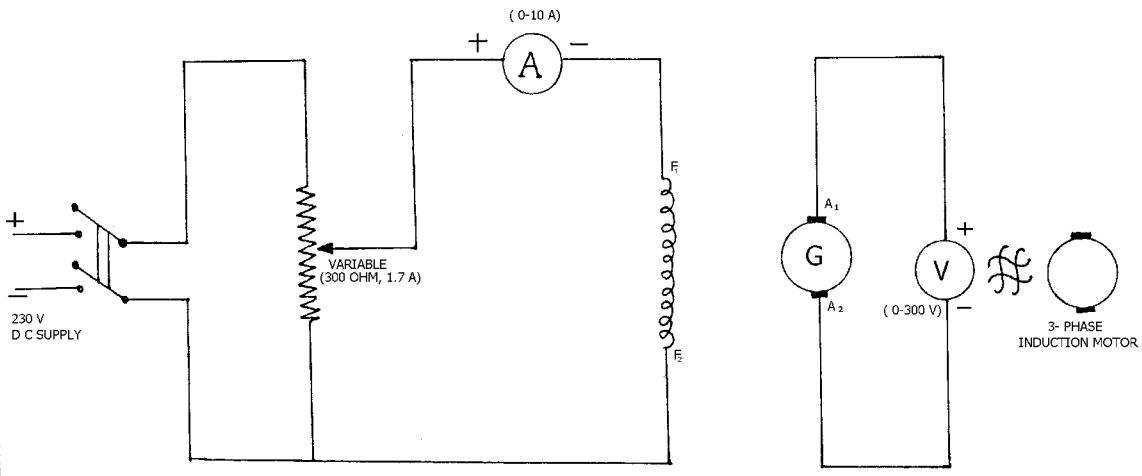

Exercise No2: (2 Hours) - 1 Practical

Load characteristics of d. c. Compound generator.

AIM- To study load characteristics of d. c. Compound generator.

- a) Cumulative compound generator.
- b) Differential compound generator.

APPARATUS-

- 1) Rheostat (120, 0.6 amp) -----1no
- 2) Rheostat (500, 1.2 amp) -----1no.
- 3) D. c. voltmeter (0-300 volt) ----- 1no.

THEORY:

- 1. What is effect of load on D. C. comp. generator ?
- 2. What is difference between cumulative & differential comp. generator?
- 3. Why terminal voltage drop is rapid in diff. Comp. D. C. generators as compared to comm. Comp. generator?

PROCEDURE:-

- 1) Make the connection as per the circuit dia. The series field is shown connected for the cumulative compound case, as per usual marking.
- 2) Start the motor and adjust its speed with the help of its field rheostat to the rated speed of generator.
- 3) Adjust the shunt field rheostat of the d. c. generator to obtain the suitable voltage at no load, say a little higher than its rated voltage at no load. Note the same.
- 4) Load the generator. Note the load currents and the corresponding terminal voltages, (up to rated load current).
- 5) Disconnect the supply and reverse the series field connections. The generator now will work as differentially compound generator.
- 6) Repeat steps (2) to (4)
- 7) Plot the terminal voltage V/s load current curve for both the cases.

OBSERVATION TABLE: -

- a) For cumulative compound generator

Sr. No	Load current in amps (I_L)	Terminal voltage. (V_L)
1		
2		
3		
4		
5		

- b) For differential compound generator

Sr. No	Load current in amps (I_L)	Terminal voltage. (V_L)
1		
2		
3		
4		

GRAPH :

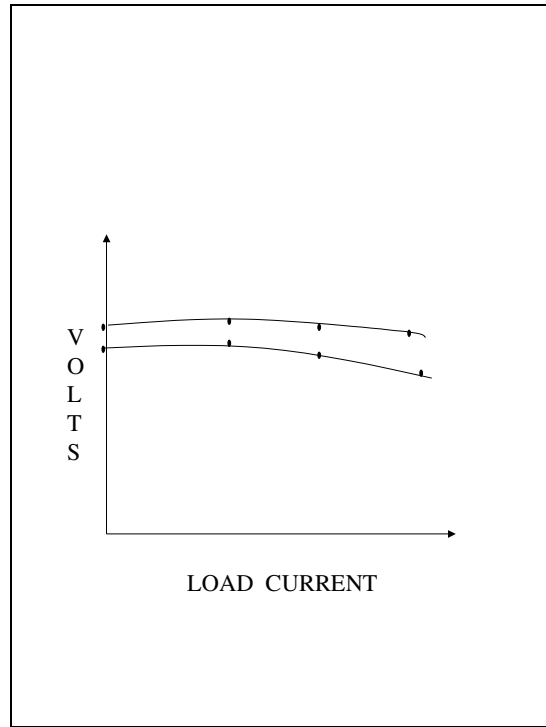

CONCLUSION: -

The variation of terminal voltage with load current for the two types of d. c. compound generator is taken. It is observed that with the differentially compound generator, the terminal voltage falls more rapidly with the load while with the cumulative generator, terminal voltage remains almost constant.

LOAD CHARACTERISTICS OF D.C. COMPOUND GENERATOR

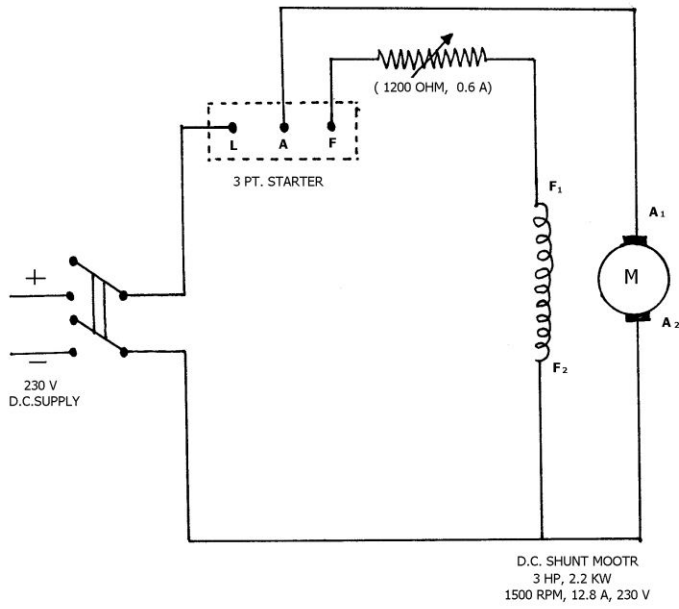

#

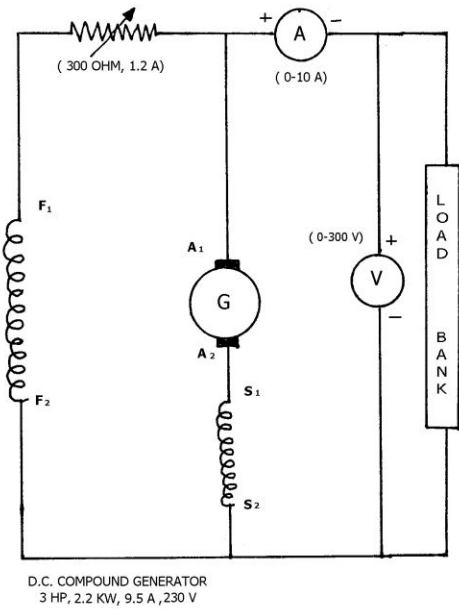

Exercise No3: (2 Hours) - 1 Practical

Speed control of a d. c. shunt motor.

AIM: to study the speed control of a d. c. shunt motor.

- a) By varying field current with armature voltage kept constant.
- b) By varying armature voltage with field current kept constant.

APPARATUS:-

- 1) Rheostat (100Ω 1.2 amp) ----- 1no
- 2) Rheostat (100Ω 6.0 amp) ----- 1no
- 3) D. c. voltmeter (0-300volt) -----1no.
- 4) D.C. Ammeter (0-1A) ----- 1no

THEORY:

- 1. What is effect of voltage on D. C. shunt motor?
- 2. What are different factors which affect the speed of D. C. shunt motor?

PROCEDURE: -

- 1) Make the connections as per circuit dia.
- 2) Set up the field and armature rheostat to their maximum value.
- 3) Switch on the D.C. Supply start the motor with the help of starter. Adjust the field current to rated value.
- 4) Note the speed with the help of tachometer, the voltage across armature and the field current.
- 5) Change the speed by varying the rheostat in the armature circuit. Note the speed and armature voltage, the field current remaining constant.
- 6) Repeat steps 4. And 5. Above, for different field currents.
- 7) Plot speed V/s armature voltage
- 8) Keep the rheostat in the armature circuit to some fixed value. Note the voltage across armature. Note the field current and speed.
- 9) Vary the field current.

OBSERVATION TABLE:-

- a) Armature voltage variation.
- 1) Field current (constant) = _____amps.

Sr. no.	Armature voltage (Va in volts)	Speed (r.p.m)
1.		
2.		
3.		
4.		
5.		
6.		

b) Variable Field current

1) Armature voltage (constant) = _____ volts.

Sr. no	Field current (If in amps)	Speed (r.p.m.)
1.		
2.		
3.		
4.		
5.		
6.		

GRAPH:

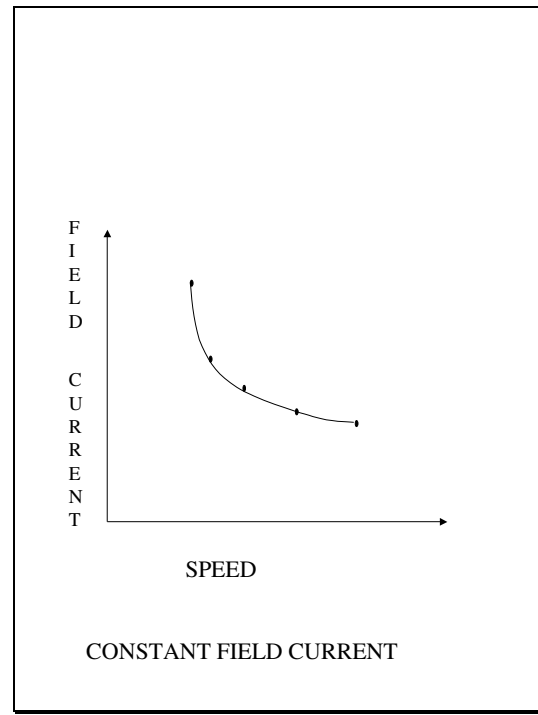
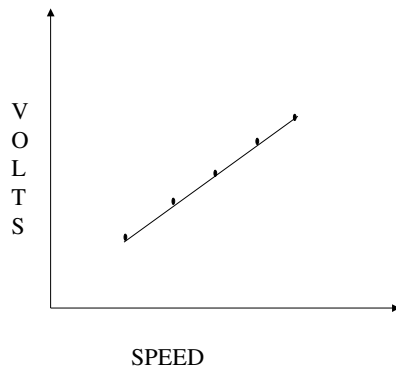

CONCLUSION:-

The variation of speed with armature voltage and field current has been studied. The speed of d. c. Shunt motor is directly proportional to the armature voltage and inversely proportional to the field current. Thus, to increase speed above rated speed field current should be decreased & to decrease the speed below rated speed armature voltage should decrease.

SPEED CONTROL OF D.C. SHUNT MOTOR

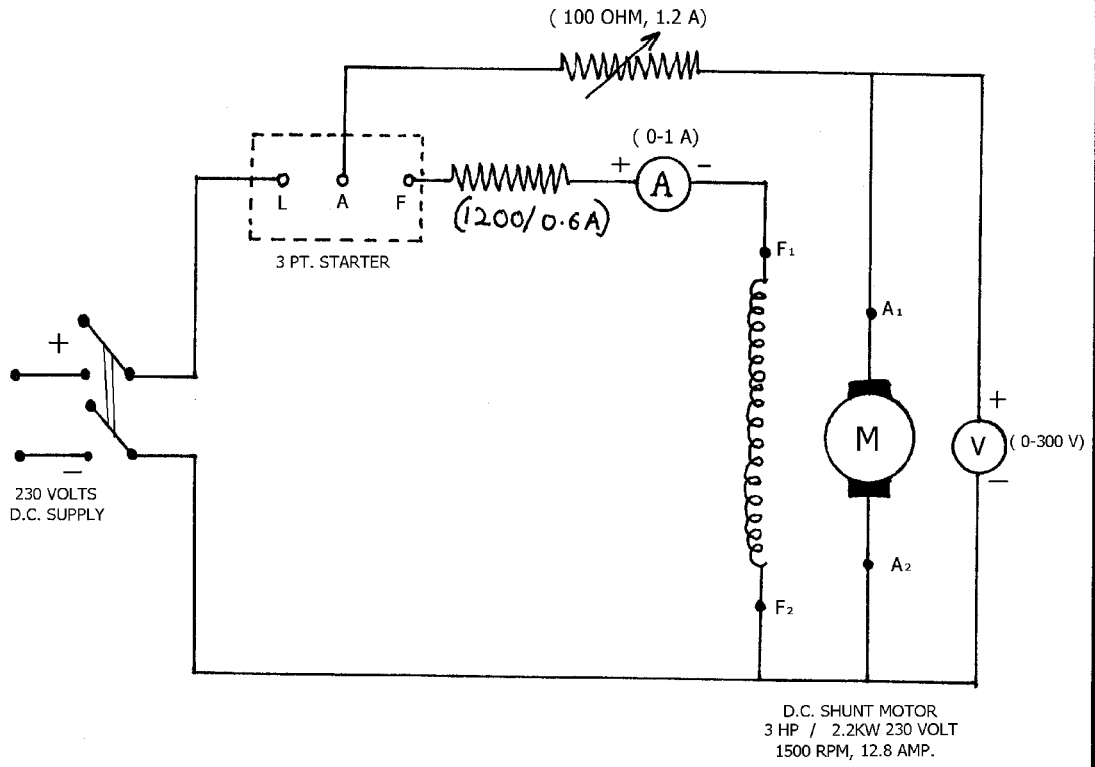

Exercise No4: (2 Hours) - 1 Practical

Load test on D.C. shunt motor.

AIM- To perform load test on D.C. shunt motor

APPARATUS-

- 1) Rheostat (570 ohm, 1 Amp) ----- 1 no
- 2) Rheostat (300 ohm, 1.7 amps) -----1no.
- 3) D. c. voltmeter (0-10ohm) -----2no.
- 4) D. c. voltmeter (0-300v) -----2no
- 5) Tachometer.

THEORY:

1. What is effect of load on D. C. shunt motor?
2. What is the relation between efficiency & load of D. C. shunt motor?
3. Why current & torque increases linearly with the load?

PROCEDURE

- 1) Make the connection as per circuit dia.
- 2) Set the field rheostat of motor to zero and field rheostat of generator to maximum.
- 3) Switch on D.C. supply and start the motor with the help of starter.
- 4) Adjust field rheostat for motor to obtain rated speed. For one set of readings the setting of field rheostat should not be altered.
- 5) Adjust D.C. shunt generator voltage to it's rated voltage with the help of it's field rheostat.
- 6) Load the generator with keeping it's terminal voltage constant.
- 7) Note the reading of ammeters, voltmeters and speed.
- 8) Repeat (6) and (7) above to a cover the range of no load to full load of motor.
- 9) Plot speed vs. output, armature current Vs output, efficiency Vs output, torque vs. output curves

SAMPLE CALCULATION-

Efficiency of generator is assumed as 87%

Generator output = $V_g I_g$ watts.

Generator input = generator output / 0.87

Generator input = motor output.

Motor input = $V_m I_m$ watts.

% Motor efficiency = (motor output / motor input) * 100

Motor Torque = $\frac{(\text{motor output in watts}) * 60}{2\pi n}$ N-M

OBSERVATION TABLE:

Sr.No.	GENERATOR		MOTOR		SPEED (rpm)	MOTOR I/P (watts)	MOTOR O/P (watts)	EFFI. OF MOTOR	TORQUE (N.M)
	Vg	Ig	Vm	Im					
1									
2									
3									
4									
5									

GRAPH :

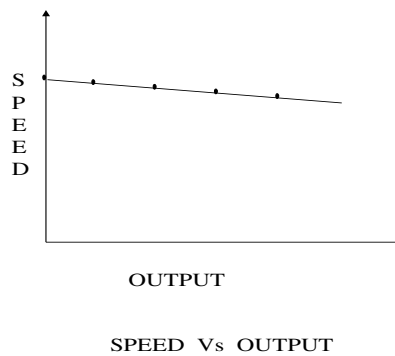
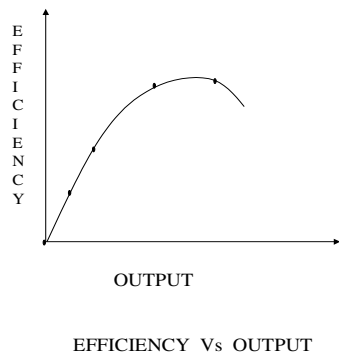
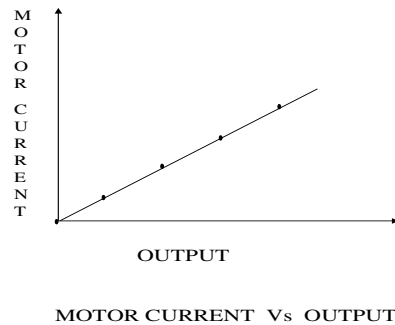
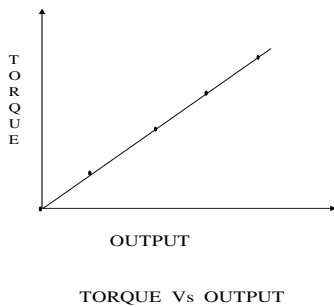

CONCLUSION-

From the above graphs, the motor current increases with the load, and the speed decreases slightly with increase in load. The efficiency initially increases with the load, and then reaches its maximum (at about 80 to 90 % of the full load) and then decreases.

LOAD TEST ON D.C. SHUNT MOTOR

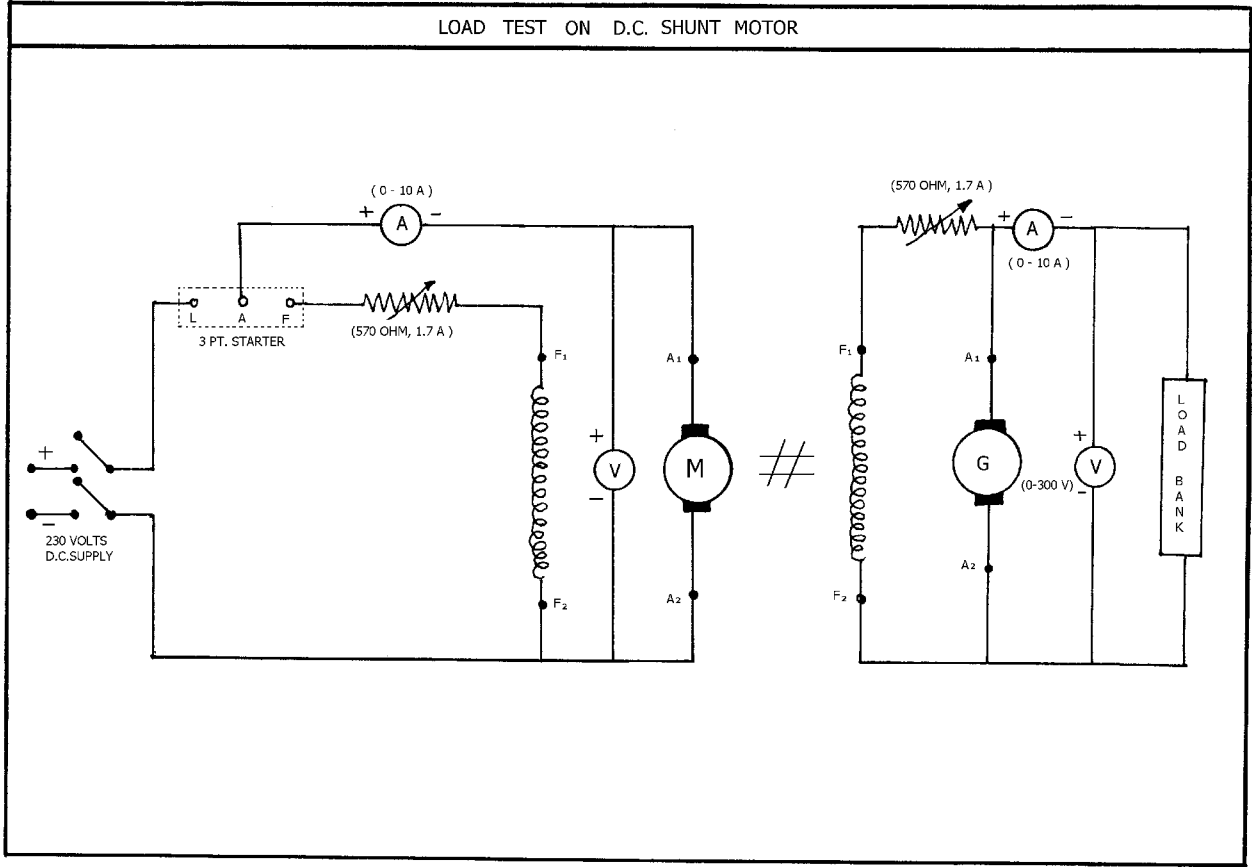

Exercise No5: (2 Hours) - 1 Practical

Three phase transformer connection

AIM: To study the Three phase Transformer Connections, which are commonly used & To study their Voltage relation.

APPARATUS : -

1. 3 Phase Transformer.
2. Voltmeter (0-600V)

THEORY:

1. What are the different transformer connections?
2. What is phase shift between prim. & sec. of 3 phase transformer?
3. What are the different applications of transformer?

PROCEDURE:

- 1) Take three phase transformer.
- 2) Make connections as per the circuit diagram
- 3) For that connections, measure Line & Phase Voltage for Primary & Secondary sides.
- 4) Repeat this procedure for all types of connection..

OBSERVATIONS:

1. For Y-Y Connected Transformer: Measured value

$$(V_{p1}) = \quad , (V_{11}) = \quad , (V_{p2}) = \quad , (V_{12}) =$$

2. For $\Delta - \Delta$ Connected Transformer: Measured value

$$(V_{p1}) = \quad , (V_{11}) = \quad , (V_{p2}) = \quad , (V_{12}) =$$

3. For Y - Δ Connected Transformer: Measured value

$$(V_{p1}) = \quad , (V_{11}) = \quad , (V_{p2}) = \quad , (V_{12}) =$$

4. For $\Delta - Y$ Connected Transformer: Measured value

$$(V_{p1}) = \quad , (V_{11}) = \quad , (V_{p2}) = \quad , (V_{12}) =$$

CALCULATIONS:

1.
Find $[(V_{P2}) / (V_{p1})] =$ & $[(V_{12}) / (V_{11})] =$
& Check the Relation as below: ----

1. For $\Delta - \Delta$ Connection

$$(V_{p1}) = (V_{11})$$

$$\text{Find } [(V_{P2}) / (V_{p1})] = K \text{ \& } [(V_{12}) / (V_{11})] = K$$

2. For Y- Δ Connection

$$(V_{p1}) = 3 \cdot V_{p1};$$

$$[(V_{p2}) / (V_{p1})] = K \text{ \& } [(V_{12}) / (V_{11})] = K$$

3. For Δ - Y Connection

$$(V_{p11}) = 3 \cdot V_{p1};$$

$$[(V_{p2}) / (V_{p1})] = K \text{ \& } [(V_{12}) / (V_{11})] = K / 3$$

4. For Y-Y Connection

$$(V_{p1}) = (V_{11}); (V_{p2}) = (V_{12}) / 3;$$

$$[(V_{p2}) / (V_{p1})] = K \text{ \& } [(V_{12}) / (V_{11})] = 3 \cdot K$$

CONCLUSION:

All the Transformer Voltages verifies the Relation given between Line & Phase Voltages.

TRANSFORMER CONNECTIONS

1. Y - Y CONNECTION

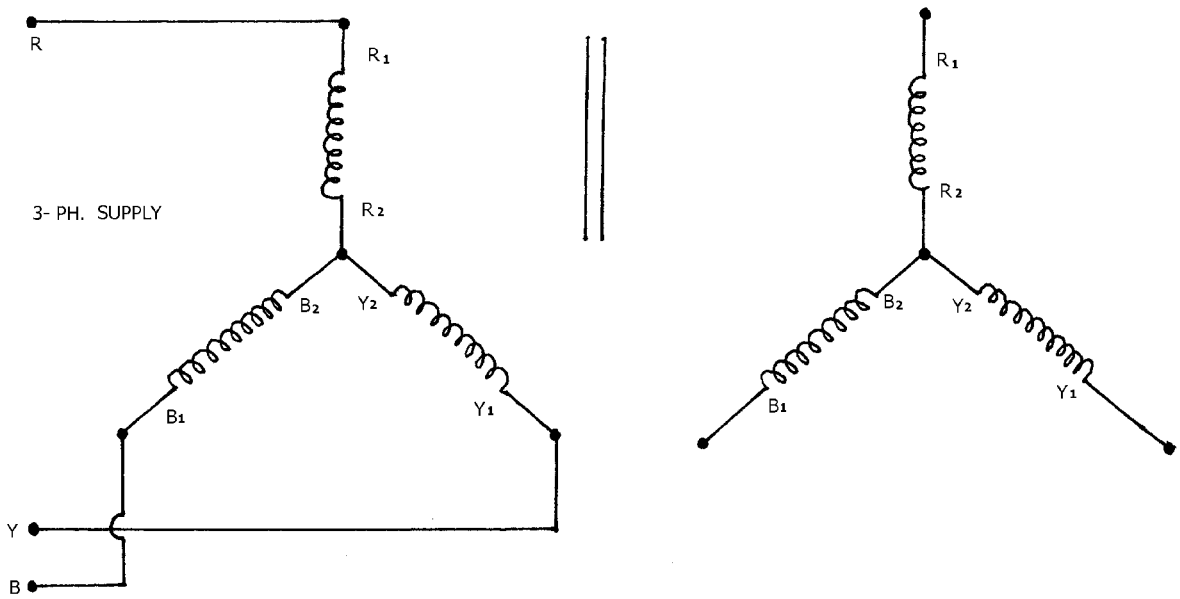

2. Δ - Δ CONNECTION

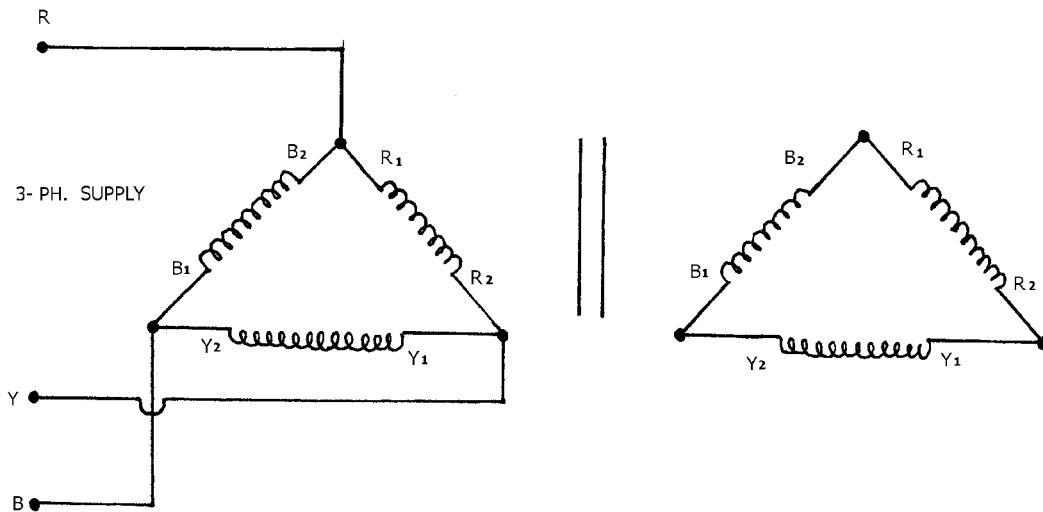

TRANSFORMER CONNECTIONS

3. Y - Δ CONNECTION

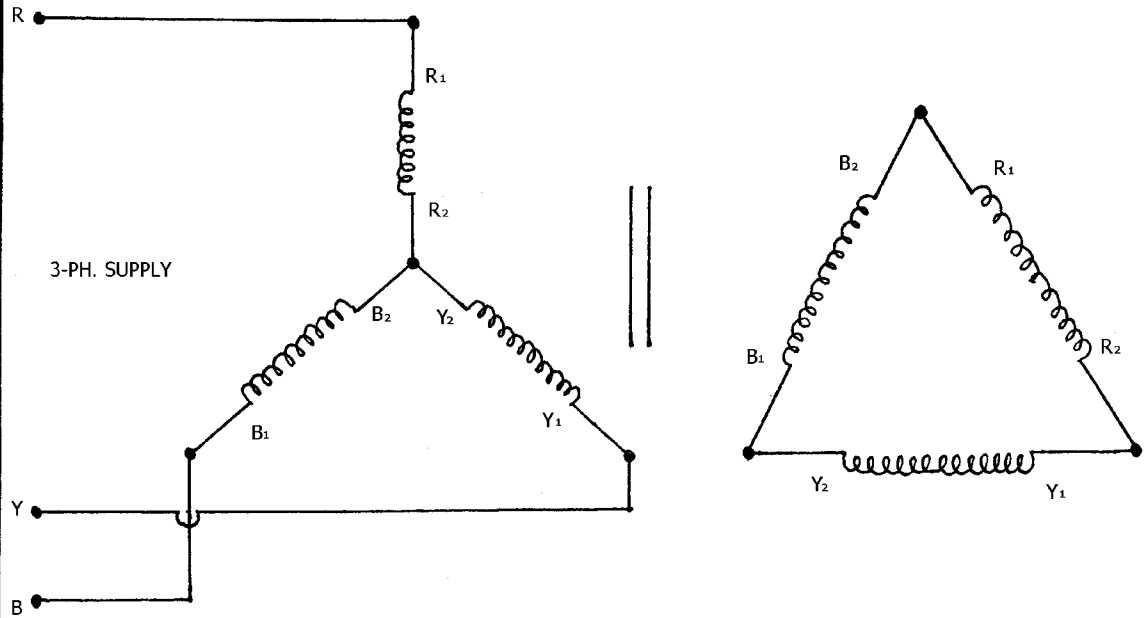

4. Δ - Y CONNECTION

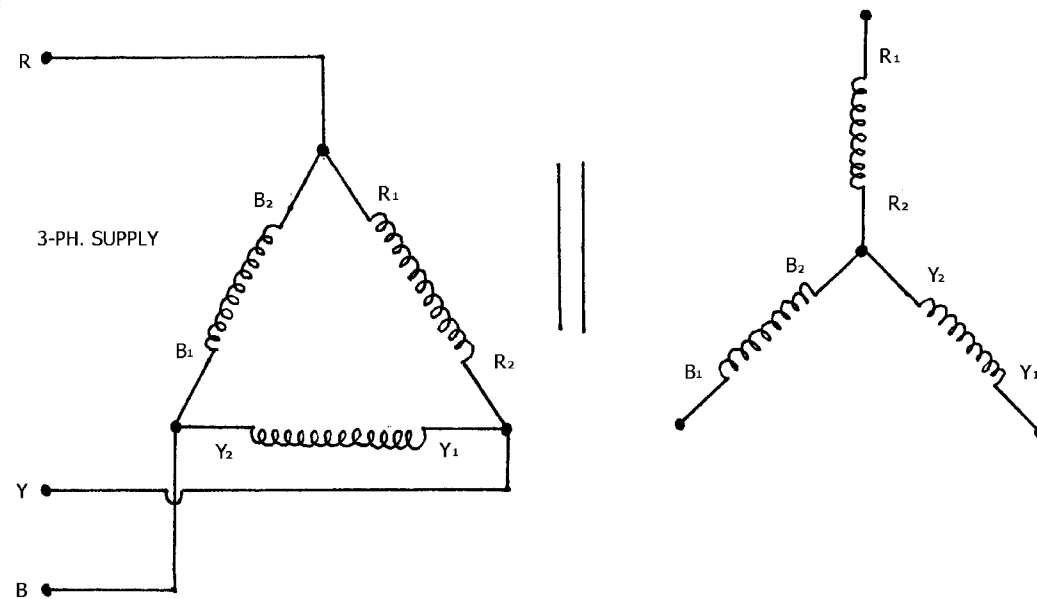

Exercise No6: (2 Hours) - 1 Practical

D. C. motor starter

At starting, $E_b = 0$ because speed of motor is zero. Armature current of motor is equal to,

$$I_a = \frac{V - E_b}{R_a}$$

$$\text{so } I_a = \frac{V}{R_a} \quad (E_b = 0)$$

Since R_a is very small so motor will draw large armature current. To limit the armature current in safe value we add some external resistance in armature circuit. A mechanism which adds resistance during starting only is known as starter.

THEORY

There are two types of starters which are commonly used for d.c. shunt motor

- 1) 3-point starter
- 2) 4 - point starter

3- POINT STARTER

Three point starters is shown in the figure 1, when motor is started, starting arm is moved slowly towards the ON position

- 1) As soon as arm touches the stud no. 1 full starting resistance gets connected in the armature circuit.

- 1) Field current receives supply directly

The starting armature current is equal to,

$$I_a = \frac{V}{(R_a + R_{st})}$$

- 2) The arm is moved against the spring force towards the ON position.
- 3) When the arm travels towards ON position, the starting resistance is gradually removed from armature circuit. Since motor takes full speed, motor develops full back E.M.F. the starting arm carries a soft iron piece which is held by attraction of the hold on coil. starter remains in ON position because the electromagnetism formed by NO VOLT COIL

FUNCTION OF HOLD ON (NO VOLT COIL)

- 1) In case of supply failure NO VOLT COIL gets de-energized and the starting arm will be released to OFF position. This is automatically done by spring action.
- 2) It hold the plunger in ON position
- 3) It gives the protection against field failure

FUNCTION OF OVERLOAD COIL

Overload coil is a electromagnet connected in series with armature. When current exceeds beyond certain predetermined value the electromagnet will become strong and it attracts plunger. Due to this voltage across NO VOLT COIL becomes zero. This will make hold on coil de -energized due to which arm gets to OFF position and motor gets disconnected from supply.

LIMITATIONS OF THREE POINT STARTER

- 1) When motor is in ON position the starting resistance gets removed from armature circuit at the same time it gets attached to field circuit, which is dangerous to the motor.
- 2) When we control speed of motor by field control method, resistance in field circuit reduces field current which increases the speed of motor at the same time there is a chance under ON condition motor could disconnect from supply due to de-energisation of HOLD ON COIL, due to less field current.

4- POINT STARTER

4- Point starter with brass arc covers limitations of 3- point starter; using brass arc covers first limitation. Making field circuit path independent of hold coil circuit by making fourth point in addition with 3-point circuit covers second limitation.

When field current is reduced while controlling speed of motor will not effect on magnetic field of hold on coil because circuit of hold coil is separate than field coil circuit as shown in the fig.2.

THREE POINT STARTER

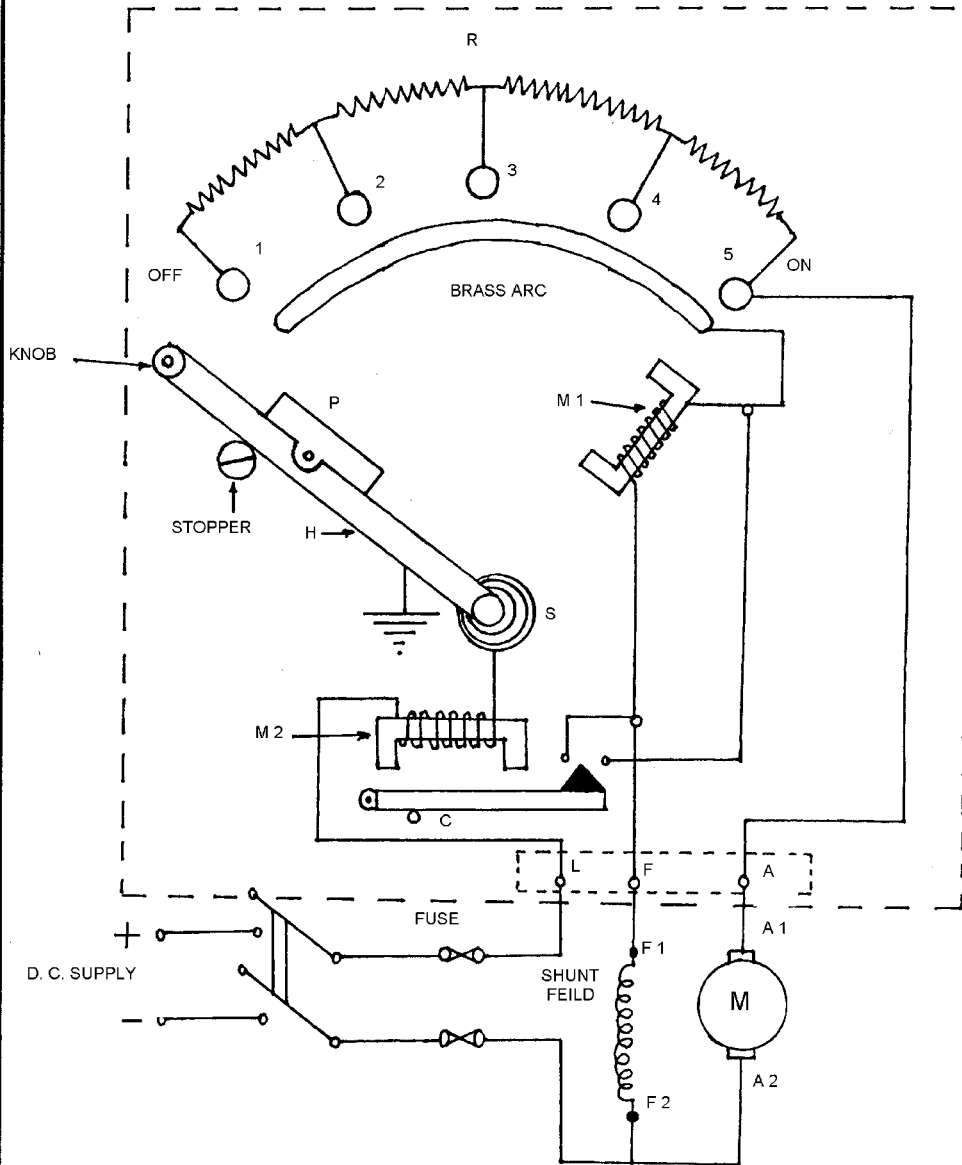

- P - SOFT IRON PIECE
- H - HANDEL
- S - SPIRAL SPRING
- M 1 - HOLD ON COIL
- M 2 - OVER LOAD COIL
- C - CUREENT CONTROL RELAY

4 POINT STARTER

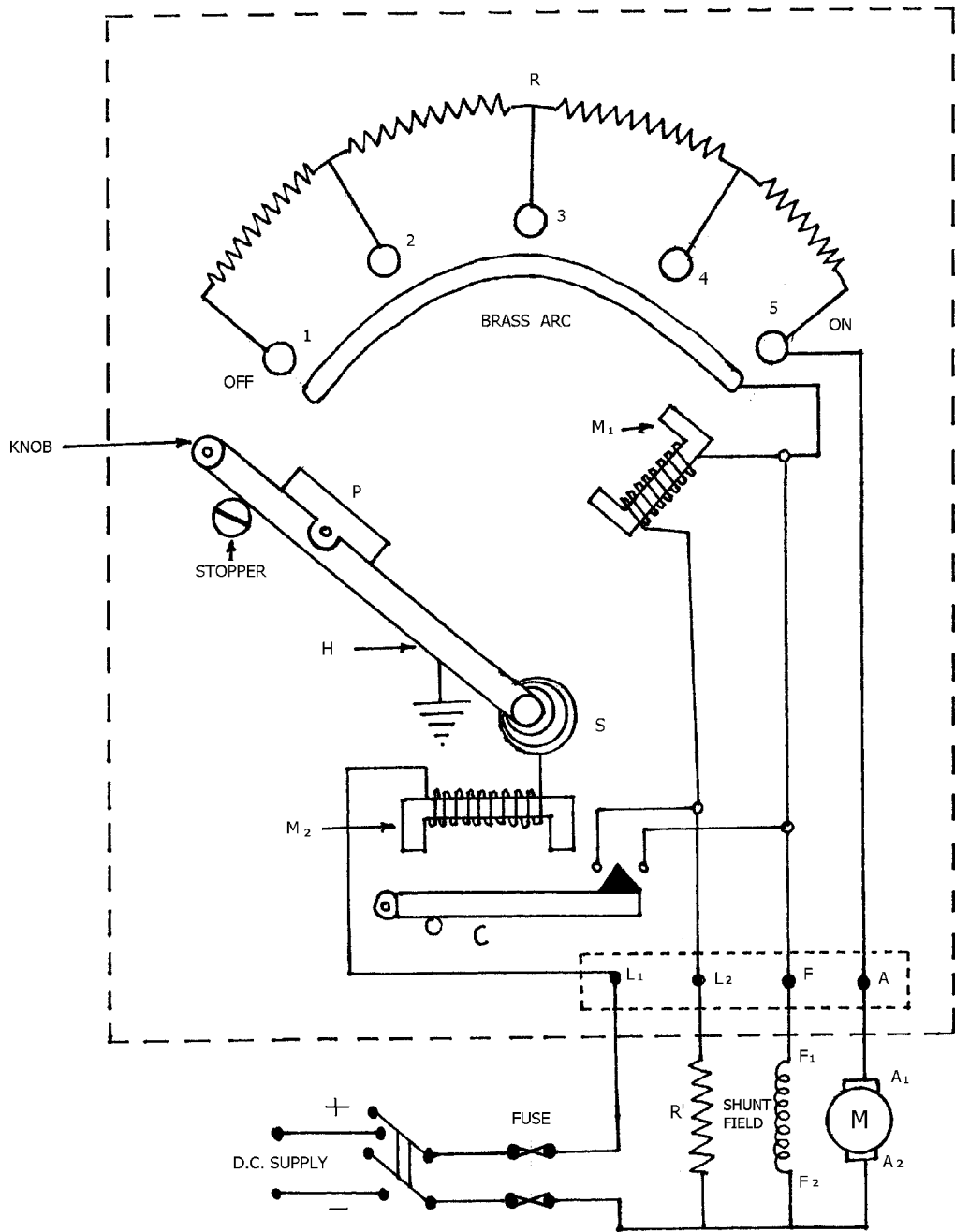

- C - CURRENT CONTROL RELAY
- M₂ - OVER LOAD COIL
- P - SOFT IRON PIECE
- H - HANDLE
- S - SPIRAL SPRING
- M₁ - HOLD ON COIL

Exercise No7: (2 Hours) - 1 Practical

Polarity test and ratio test on 1 phase transformer.

AIM: To Perform Polarity test and ratio test on 1 phase transformer.

APPARATUS:-

- 1) Variac----- 1no
- 2) AC Voltmeter (0-150v-300v)
- 3) AC Ammeter (0-1-5-10A)
- 4) Line cord

THEORY:

1. What is polarity of transformer?
2. Explain the significance of Additive and subtractive polarity?
3. What is transformer turns ratio?
What is its significance?

PROCEDURE: -

Polarity Test

1. Make the connections as per circuit dia.
2. Switch on the supply
3. Take the reading of voltages V1, v2, V3. In case of $V2 < V1$ the polarity is subtractive.
4. Repeat the step 3 after connecting A1 and a2 in case $V3 > V1$ the polarity is additive.
5. Switch off the A.C. supply.

Ratio Test:

1. First, the tap changer of transformer is kept in the lowest position and LV terminals are kept open.
2. Then apply 1-phase 230 V supply on HV terminals. Measure the voltages applied on HV and induced voltages at LV terminals simultaneously,
3. After measuring the voltages at HV and LV terminals, the tap changer of transformer should be raised by one position and repeat test.
4. Repeat the same for each of the tap position separately. Calculate the turns ratio by using formula.

$$\text{Theoretical turn ratio} = \frac{\text{HV winding voltage}}{\text{LV winding voltage}}$$

CIRCUIT DIAGRAM:

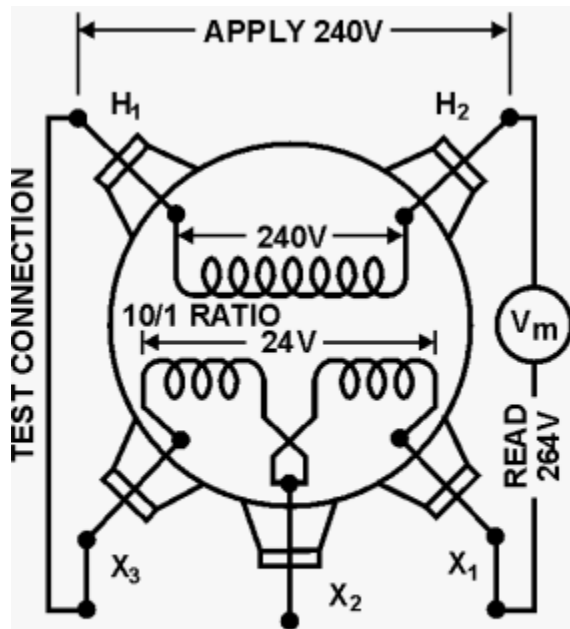
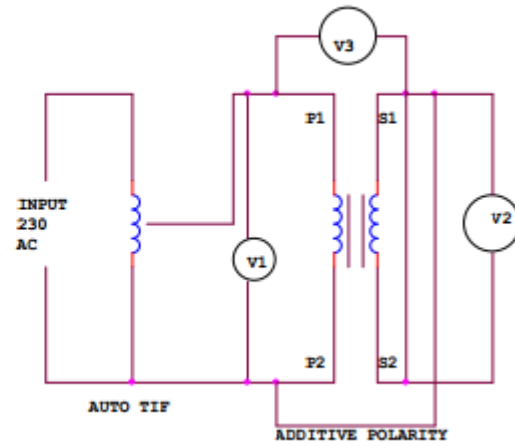
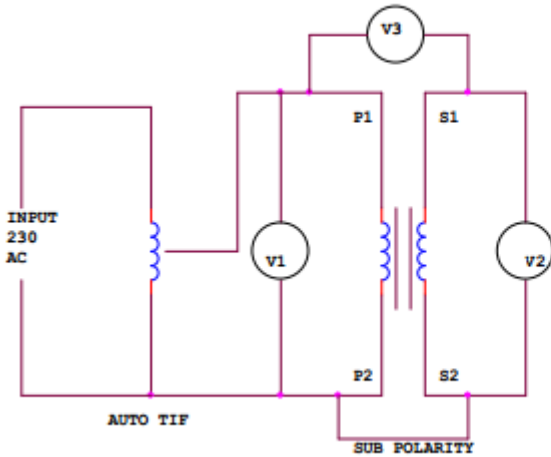

ADDITIVE POLARITY
 $240V + 24V = 264V$

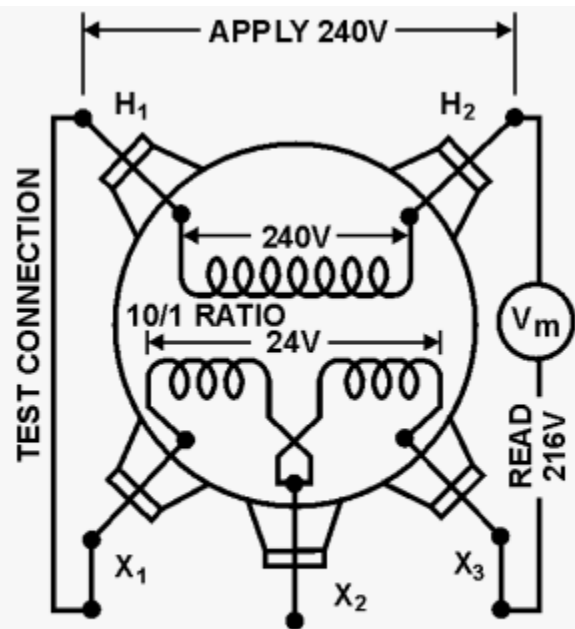

SUBTRACTIVE POLARITY
 $240V - 24V = 216V$

Observations:

Sr.no	HV side Voltage	LV side voltage	Truns ratio
1			
2			
3			

Result:

Turns ratio of given transformer is_____.

Exercise No:8 (2 Hours) - 1 Practical

To study the parallel operation of single phase transformers.

AIM: To study the parallel operation of single phase transformers.

APPARATUS:-

- 1) Wattmeter.(0-750w)..... 03 no.
- 2) AC Ammeter (0-1-5-10A).....03 no.
- 3) Single phase load.
- 4) Autotransformer
- 5) Line cord

THEORY:

1. What is need for the parallel operation of transformer?
- 2 What are the conditions for parallel operation of transformer?

PROCEDURE: -

1. Connect the circuit as shown in diagram.
2. Note down the reading of all wattmeter, ammeter, voltmeter for given load.
3. Repeat the procedure for different loads.
4. Take at least three readings.

Observations:

Sr.no	I1 (Amp)	W1(Watts)	I2(Amp)	W2(Watts)	I _L =	W _L =
1						
2						
3						
4						

Result: The two Transformer connected on Parallel share the load equally.

CIRCUIT DIAGRAM:

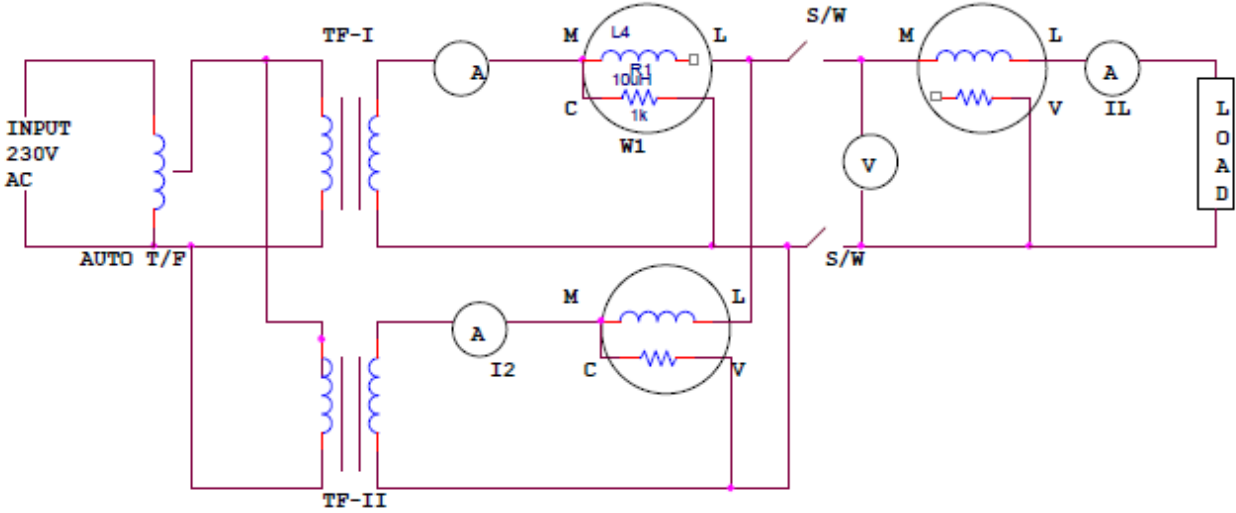

3. Quiz on the subject:

1. What is the working principle of D. C. Generator?
2. What are the different types of D C Generator?
3. What is the working principle of D. C. Motor?
4. What are the different types of D C Motor?
5. Load characteristics of D.C. Compound Generator.
 - a. What are the different types of D.C. compound Generator?
 - b. What is the difference between flat compounded & over compounded generator.
 - c. Why the terminal voltage drops when the generator is loaded?
 - d. What happens if we connect the shunt field of compound generator in series with the armature & series field across the armature?
 - e. What are the applications of d. c. compound generator?
 - f. How to identify the series field & terminal at the terminal box?
7. Speed control of D.C. Shunt motor
 - a. What are the factors on which speed of D.C. Shunt motor depends?
 - b. Name the different speed control methods.
 - C. What is the disadvantage of armature rheostat method?
 - d. What is the advantage of Ward Leonard method?
 - e. Where the D.C. Shunt motor is applicable?
8. Load test on d. c. shunt motor.
 - a. What is the purpose of Load test on d. c. shunt motors?
 - b. What is the relation between I_a and Armature Cu loss?
 - c. What are different losses in D.C. shunt motor?
9. Generators
 - a. Why speed control methods are not needed in d. c. generators?
 - b. What is the use of commutator & brushes in D C Generator?
 - c. How energy conversion takes place in D C Generator.
 - d. What is the effect of increasing load on terminal voltage in DC shunt Generator.
10. Motor
 - A. How energy conversion takes place in D C Generator.
 - B. Why D C Motor is known as constant speed motor?
 - C. Why starter is necessary for starting of D C motor?
 - D. Explain the disadvantage of 3pt. Starter.
 - E. How to reverse the direction of rotation of D C shunt Motor.
 - F. What is the use of commutator & brushes in D C Motor?)

4. Conduction of Viva-Voce Examinations:

Teacher should oral exams of the students with full preparation. Normally, the objective questions with guess are to be avoided. To make it meaningful, the questions should be such that depth of the students in the subject is tested Oral examinations are to be conducted in co-cordial environment amongst the teachers taking the examination. Teachers taking such examinations should not have ill thoughts about each other and courtesies should be offered to each other in case of difference of opinion, which should be critically suppressed in front of the students.

5. Evaluation and marking system:

Basic honesty in the evaluation and marking system is absolutely essential and in the process impartial nature of the evaluator is required in the examination system to become popular amongst the students. It is a wrong approach or concept to award the students by way of easy marking to get cheap popularity among the students to which they do not deserve. It is a primary responsibility of the teacher that right students who are really putting up lot of hard work with right kind of intelligence are correctly awarded.

The marking patterns should be justifiable to the students without any ambiguity and teacher should see that students are faced with unjust circumstances.