

# **ME 111: Engineering Drawing**

**Lecture 4**  
**08-08-2011**

**Engineering Curves and Theory of Projection**

**Indian Institute of Technology Guwahati**  
**Guwahati – 781039**

$$\text{Eccentricity} = \frac{\text{Distance of the point from the focus}}{\text{Distance of the point from the directrix}}$$

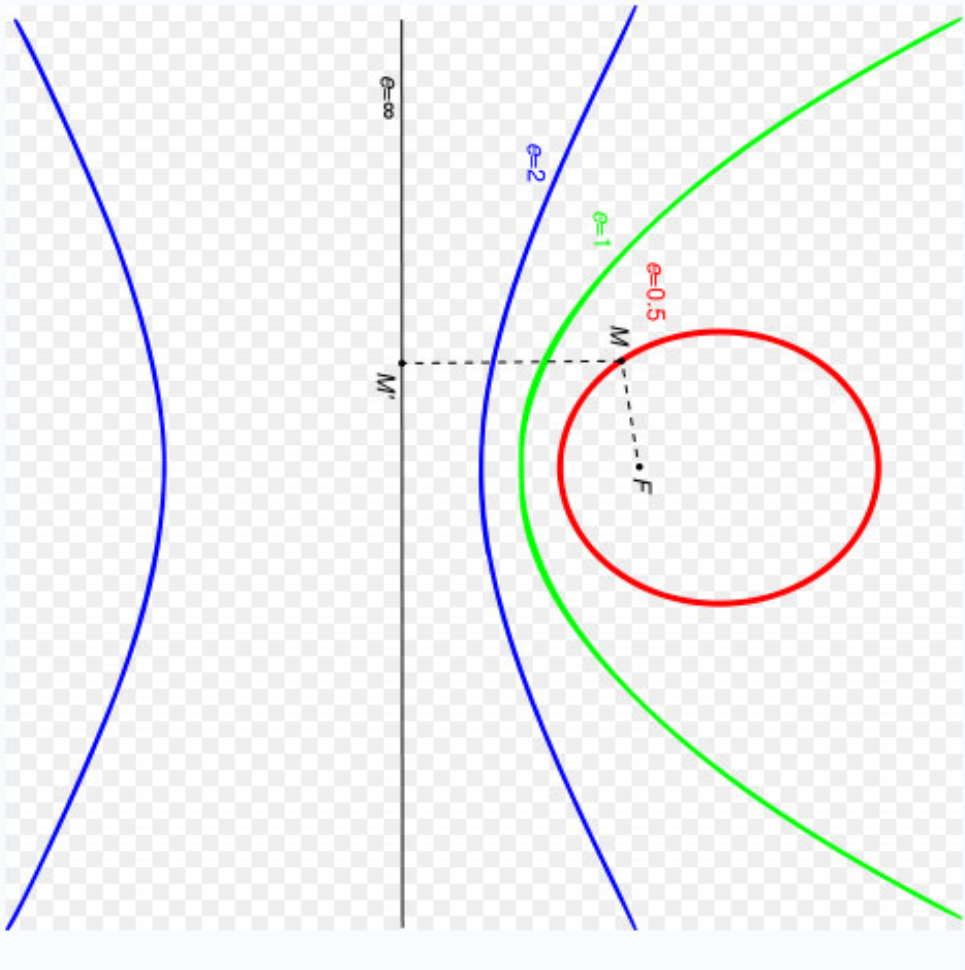

When eccentricity

$< 1 \rightarrow$  **Ellipse**

$= 1 \rightarrow$  **Parabola**

$> 1 \rightarrow$  **Hyperbola**

eg. when  $e=1/2$ , the curve is an **Ellipse**, when  $e=1$ , it is a **parabola** and when  $e=2$ , it is a **hyperbola**.

## Focus-Directrix or Eccentricity Method

**Given :** the distance of focus from the directrix and eccentricity

**Example :** Draw an ellipse if the distance of focus from the directrix is 70 mm and the eccentricity is  $3/4$ .

1. Draw the directrix AB and axis CC'
2. Mark F on CC' such that  $CF = 70$  mm.
3. Divide CF into 7 equal parts and mark V at the fourth division from C. Now,  $e = FV / CV = 3/4$ .
4. At V, erect a perpendicular  $VB = VF$ . Join CB. Through F, draw a line at  $45^\circ$  to meet CB produced at D. Through D, drop a perpendicular  $DV'$  on CC'. Mark O at the midpoint of V-V'.

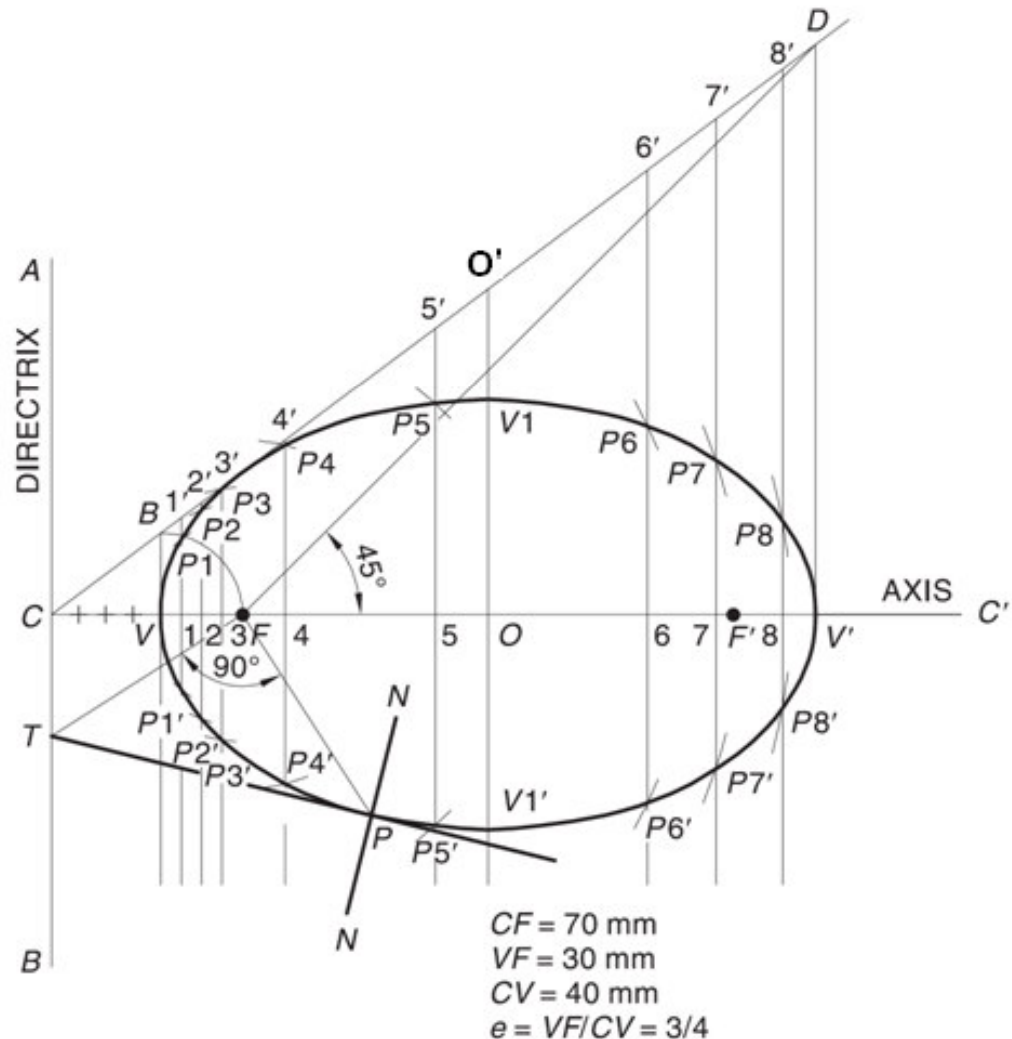

## Focus-Directrix or Eccentricity Method ( Continued)

5. With  $F$  as a centre and radius =  $1-1'$ , cut two arcs on the perpendicular through  $1$  to locate  $P_1$  and  $P_1'$ . Similarly, with  $F$  as centre and radii =  $2-2'$ ,  $3-3'$ , etc., cut arcs on the corresponding perpendiculars to locate  $P_2$  and  $P_2'$ ,  $P_3$  and  $P_3'$ , etc. Also, cut similar arcs on the perpendicular through  $O$  to locate  $V_1$  and  $V_1'$ .
6. Draw a smooth closed curve passing through  $V$ ,  $P_1$ ,  $P_2$ ,  $P_3$ , ...,  $V_1$ , ...,  $V'$ , ...,  $V_1'$ , ...  $P_3'$ ,  $P_2'$ ,  $P_1'$ .
7. Mark  $F'$  on  $CC'$  such that  $V'F' = VF$ .

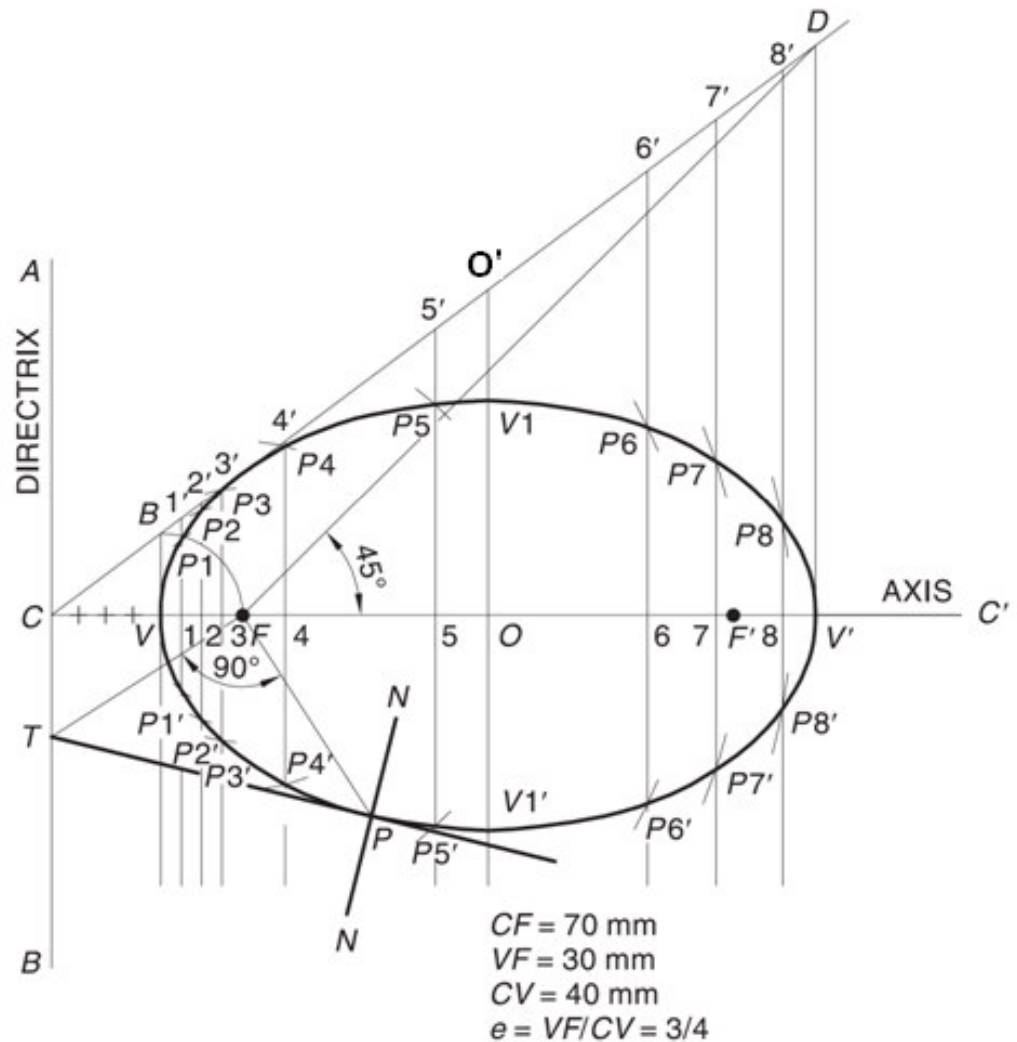

# Constructing a Parabola (Eccentricity Method)

**Example.** Draw a parabola if the distance of the focus from the directrix is 60 mm.

1. Draw directrix AB and axis CC' as shown.
2. Mark F on CC' such that CF = 60 mm.
3. Mark V at the midpoint of CF. Therefore,  $e = VF / VC = 1$ .
4. At V, erect a perpendicular VB = VF. Join CB.
5. Mark a few points, say, 1, 2, 3, ... on VC' and erect perpendiculars through them meeting CB produced at 1', 2', 3', ...
6. With F as a centre and radius = 1-1', cut two arcs on the perpendicular through 1 to locate P1 and P1'. Similarly, with F as a centre and radii = 2-2', 3-3', etc., cut arcs on the corresponding perpendiculars to locate P2 and P2', P3 and P3', etc.
7. Draw a smooth curve passing through V, P1, P2, P3 ... P3', P2', P1'.

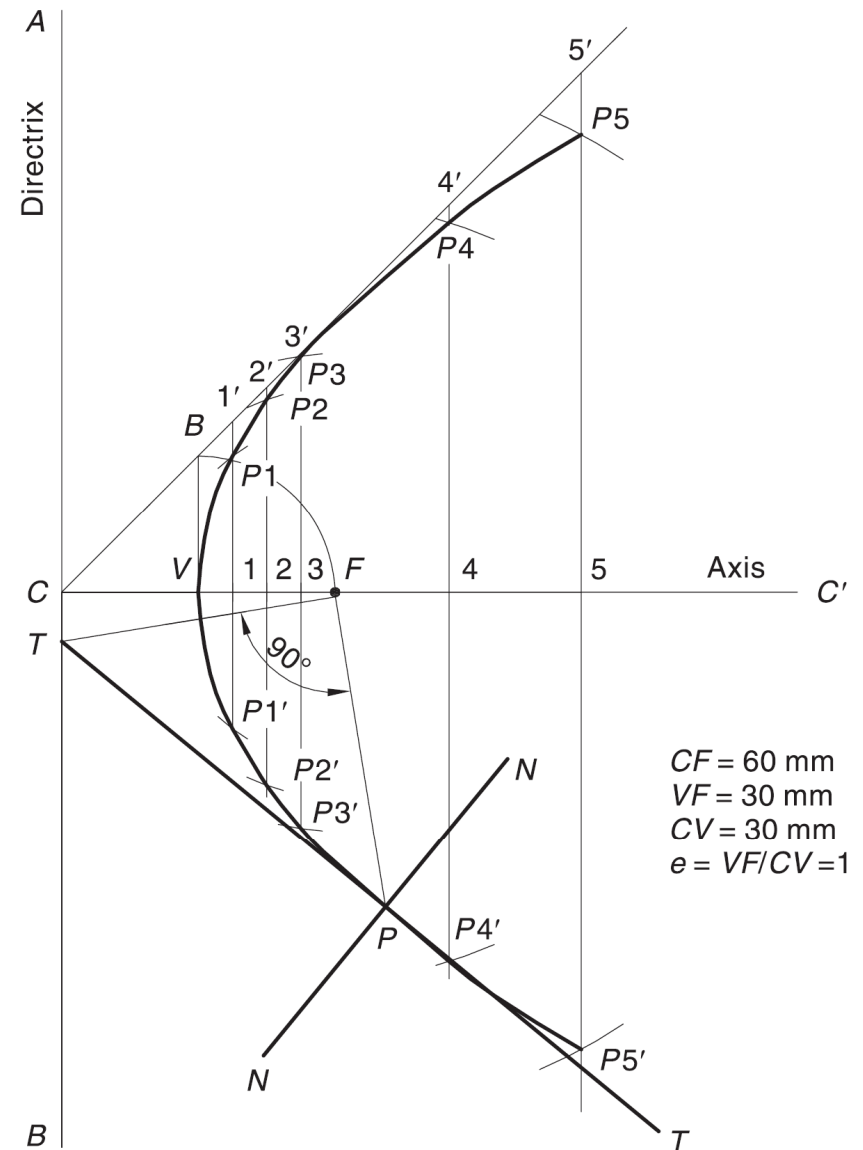



## Drawing Tangent and Normal to any conic

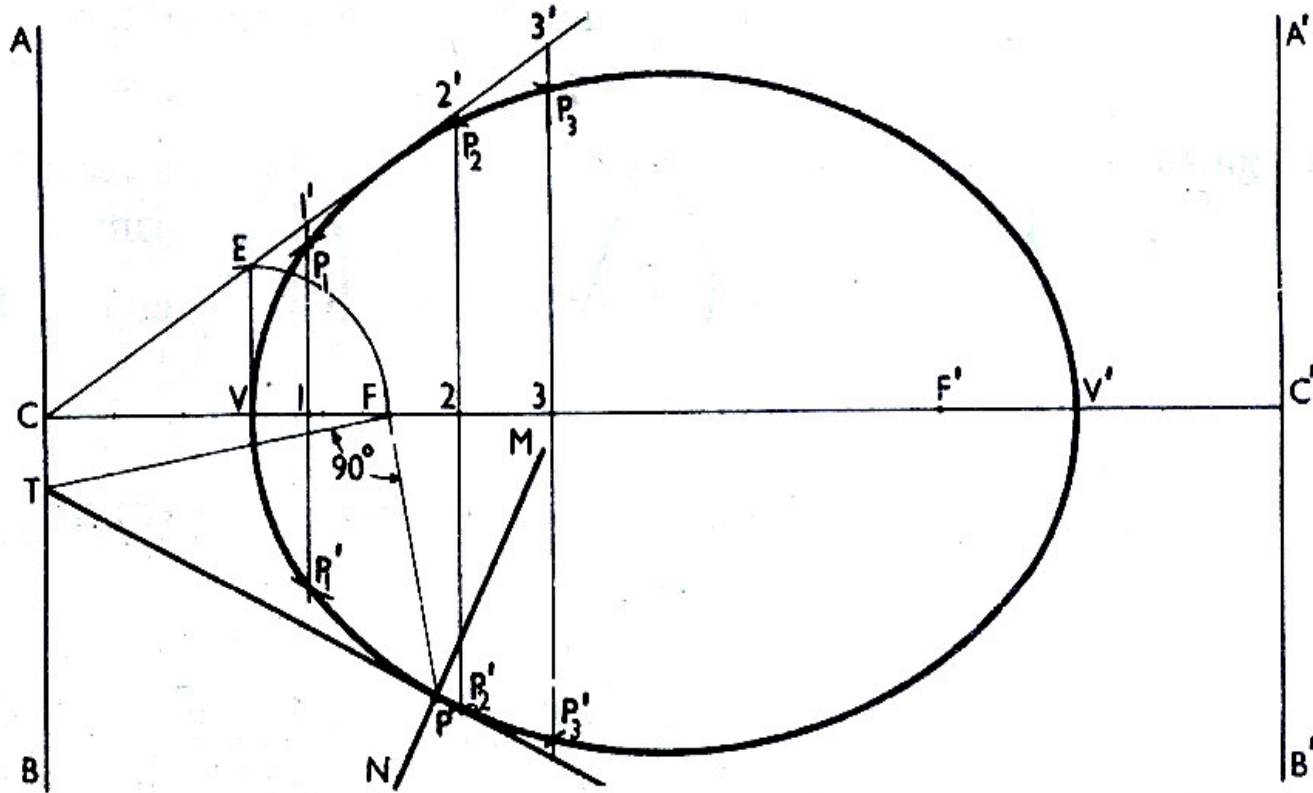

**When a tangent at any point on the curve (P) is produced to meet the directrix, the line joining the focus with this meeting point (FT) will be at right angle to the line joining the focus with the point of contact (PF).**

**The normal to the curve at any point is perpendicular to the tangent at that point.**

## Another definition of the ellipse

An ellipse is the set of all points in a plane for which the sum of the distances from the two fixed points (the foci) in the plane is constant.

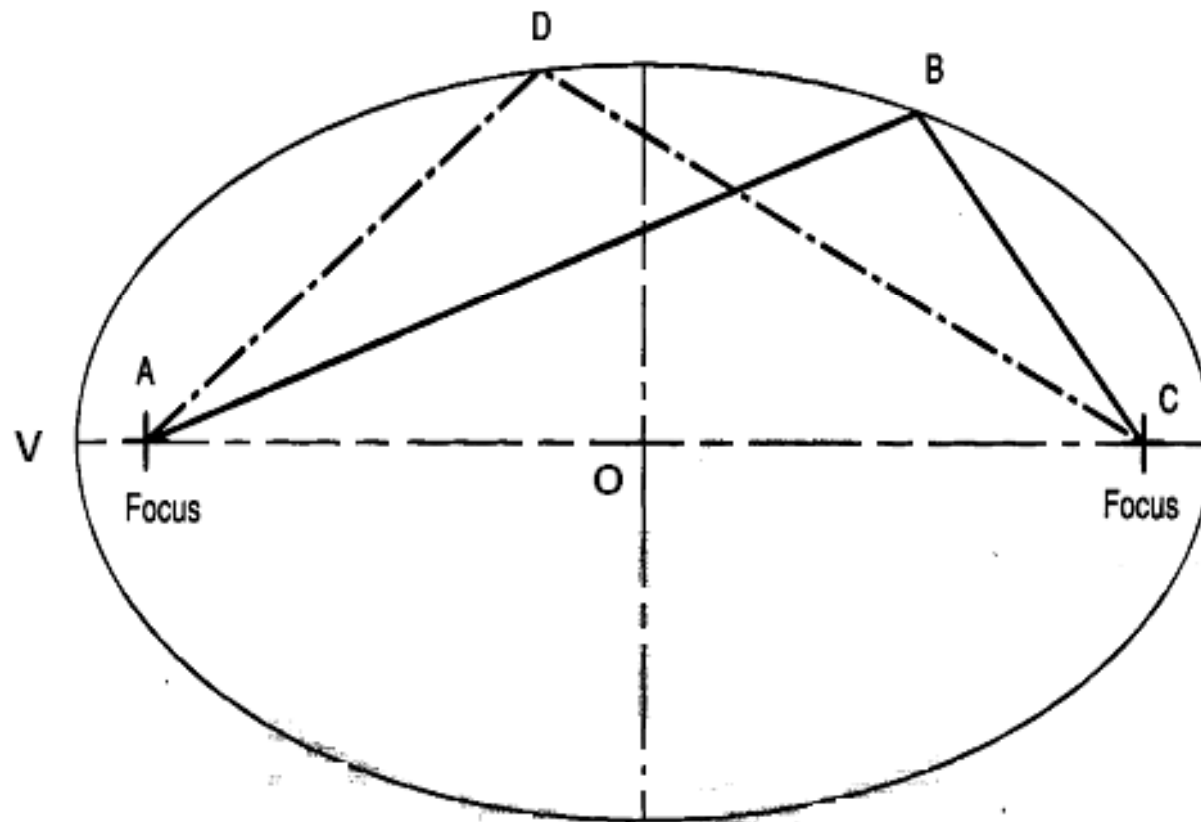

$$AB + BC = AD + DC = AV + VC$$



# Arcs of Circle Method

- Given conditions: (1) the major axis and minor axis are known **OR**  
(2) the major axis and the distance between the foci are known

Draw AB & CD perpendicular to each other as the major diameter minor diameter respectively.

With centre as C or D, and half the major diameter as radius draw arcs to intersect the major diameter to obtain the foci at X and Y.

Mark a number of points along line segment XY and number them. Points need not be equidistant.

Set the compass to radius B-1 and draw two arcs, with Y as center. Set the compass to radius A1, and draw two arcs with X as center. Intersection points of the two arcs are points on the ellipse. Repeat this step for all the remaining points.

Use the French curve to connect the points, thus drawing the ellipse.

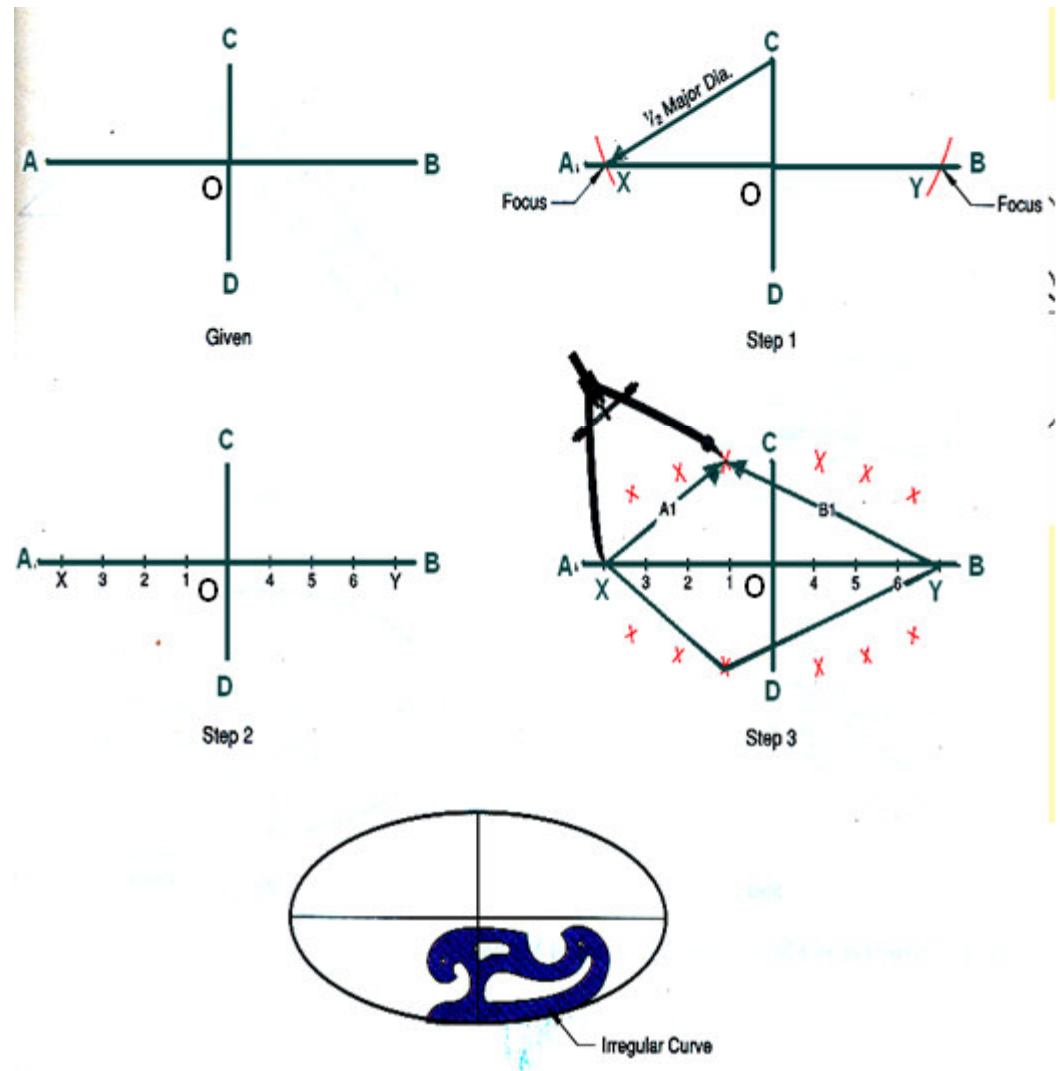

# Constructing an Ellipse (Concentric Circle Method)

**Given:**

Major axis and minor axis

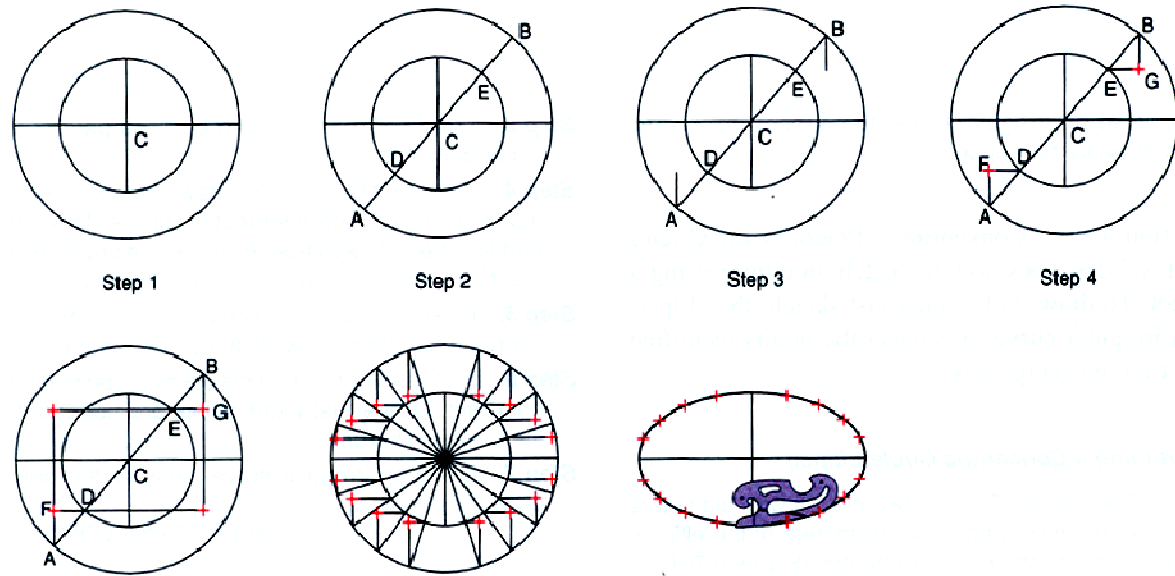

- With center C, draw two concentric circles with diameters equal to major and minor diameters of the ellipse. Draw the major and minor diameters.
- Construct a line AB at any angle through C. Mark points D and E where the line intersects the smaller circle.
- From points A and B, draw lines parallel to the minor diameter. Draw lines parallel to the major diameter through D & E.
- The intersection of the lines from A and D is point F, and from B and E is point G. Points F & G lies on the ellipse.
- Extend lines FD & BG and lines AF and GE to obtain two more points in the other quadrants.
- Repeat steps 2-6 to create more points in each quadrant and then draw a smooth curve through the points.

## Constructing a Parabola (Parallelogram Method)

**Example:** Draw a parabola of base 100 mm and axis 50 mm if the axis makes  $70^\circ$  to the base.

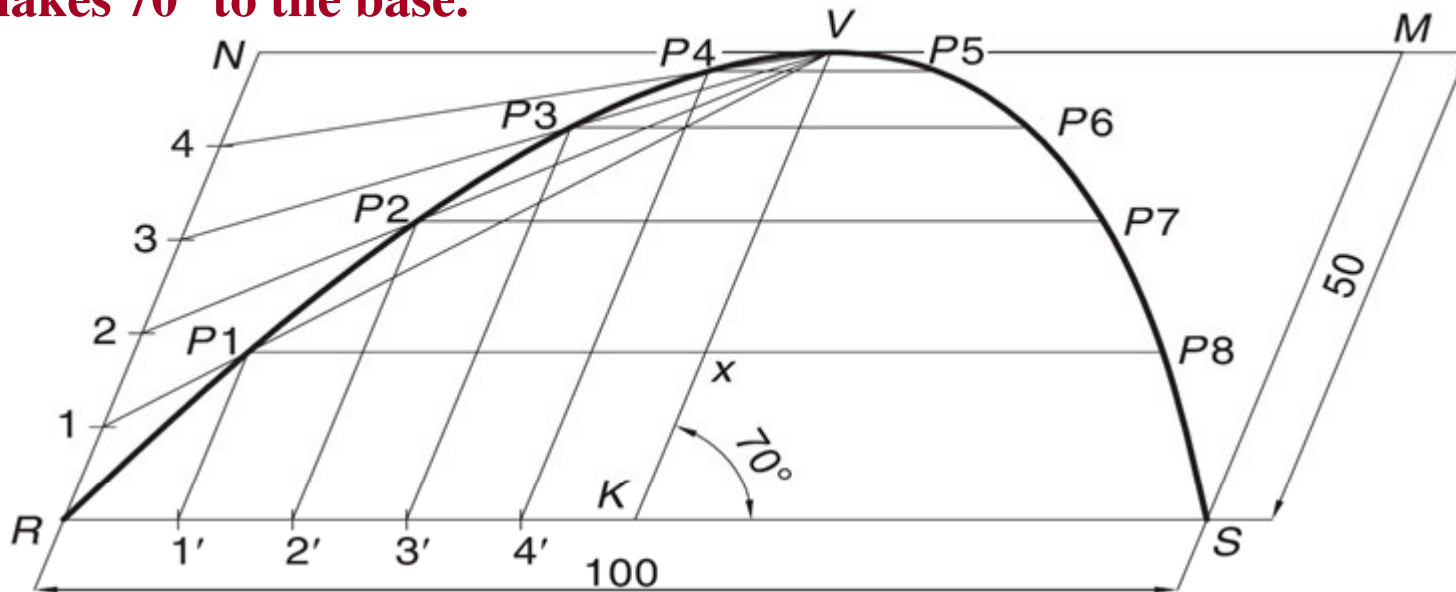

1. Draw the base  $RS = 100$  mm and through its midpoint  $K$ , draw the axis  $KV = 50$  mm, inclined at  $70^\circ$  to  $RS$ . Draw a parallelogram  $RSMN$  such that  $SM$  is parallel and equal to  $KV$ .
2. Divide  $RN$  and  $RK$  into the same number of equal parts, say 5. Number the divisions as 1, 2, 3, 4 and  $1'$ ,  $2'$ ,  $3'$ ,  $4'$ , starting from  $R$ .
3. Join  $V-1$ ,  $V-2$ ,  $V-3$  and  $V-4$ . Through  $1'$ ,  $2'$ ,  $3'$  and  $4'$ , draw lines parallel to  $KV$  to meet  $V-1$  at  $P_1$ ,  $V-2$  at  $P_2$ ,  $V-3$  at  $P_3$  and  $V-4$  at  $P_4$ , respectively.
4. Obtain  $P_5$ ,  $P_6$ ,  $P_7$  and  $P_8$  in the other half of the rectangle in a similar way. Alternatively, these points can be obtained by drawing lines parallel to  $RS$  through  $P_1$ ,  $P_2$ ,  $P_3$  and  $P_4$ . For example, draw  $P_1-P_8$  such that  $P_1-x = x-P_8$ . Join  $P_1$ ,  $P_2$ ,  $P_3 \dots P_8$  to obtain the parabola.

# Hyperbola

**A Hyperbola is obtained when a section plane, parallel/inclined to the axis cuts the cone on one side of the axis.**

**A Rectangular Hyperbola is obtained when a section, parallel to the axis cuts the cone on one side of the axis.**

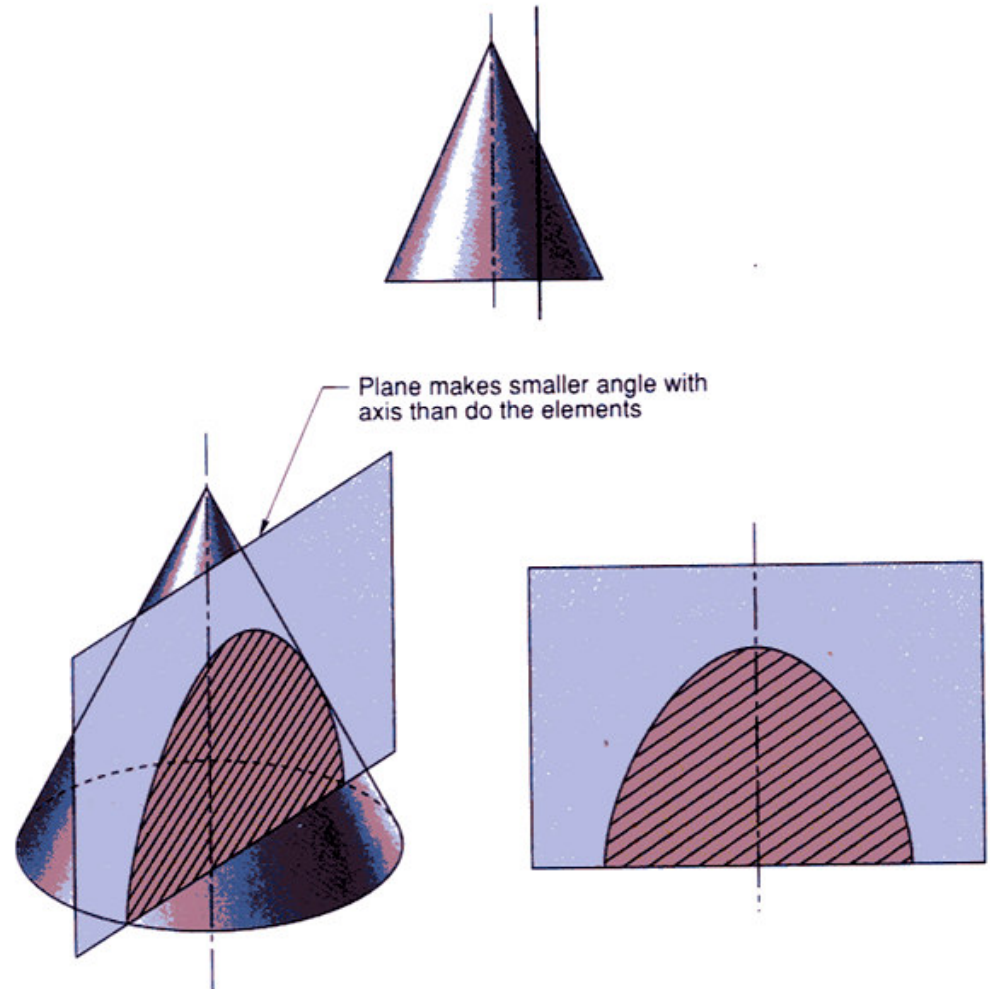

# Hyperbola

## Mathematical definition

A hyperbola is defined as the set of points in a plane whose distances from two fixed points called foci, in the plane have a constant difference.

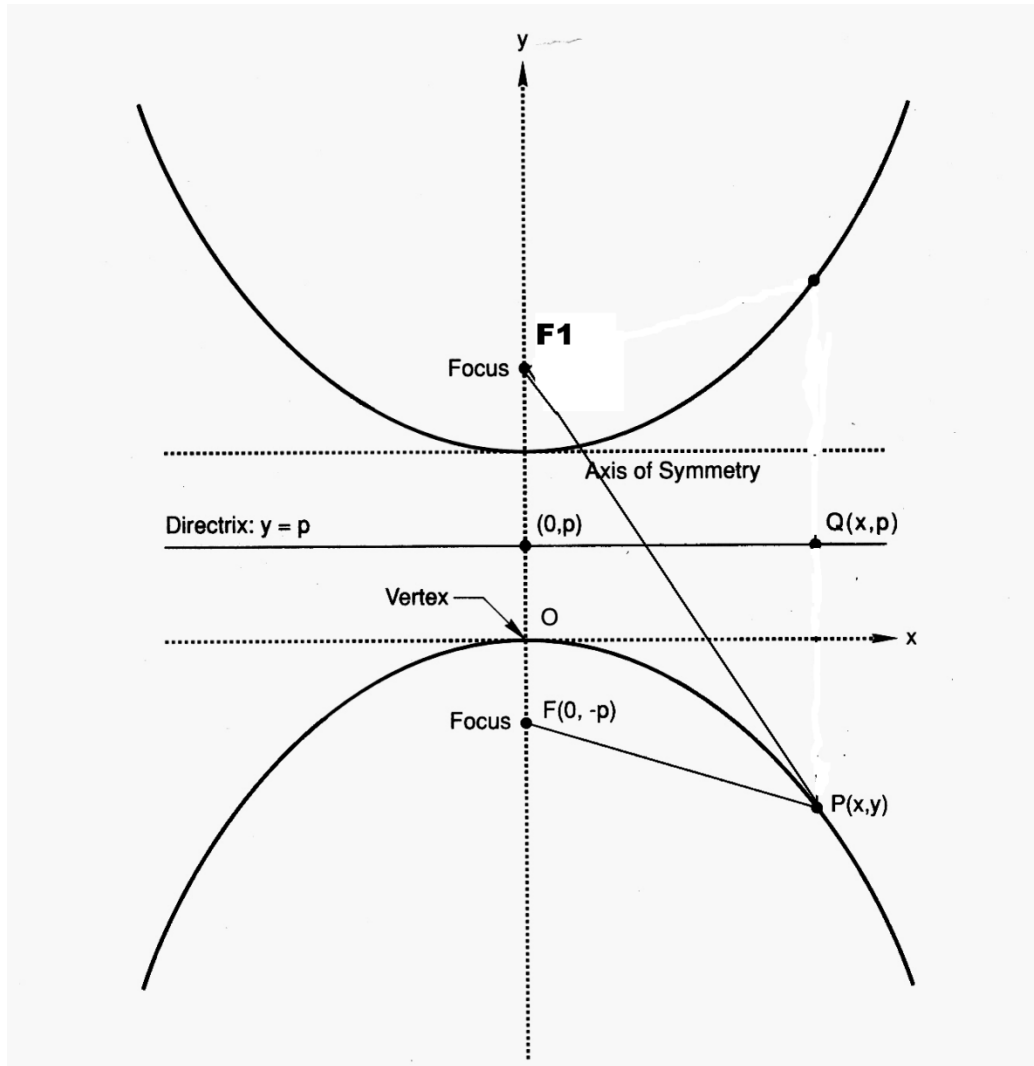

# Constructing a Hyperbola

Given: Distance between Foci and Distance between vertices

Draw the axis of symmetry and construct a perpendicular through the axis. Locate focal point **F** equidistant from the perpendicular and on either side of it. Locate points **A** and **B** on the axis equidistant from the perpendicular.

**AB** is the distance between vertices

With **F** as center and radius **R1**, and draw the arcs. With **R1 + AB**, radius, and **F** as center, draw a second set of arcs. The intersection of the two arcs on each side of the perpendicular are points on the hyperbola

Select a new radius **R2** and repeat step 2. Continue this process until several points on the hyperbola are marked

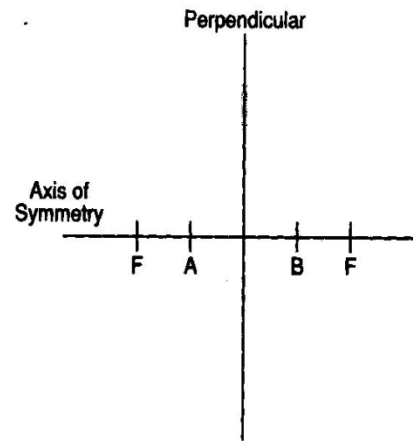

Step 1

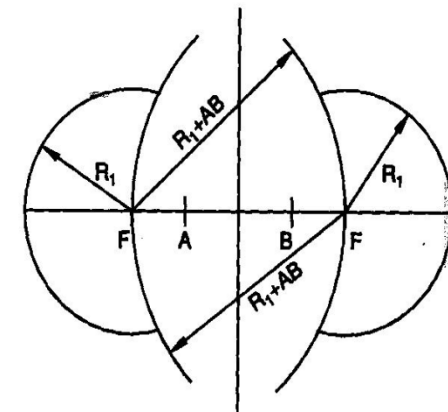

Step 2

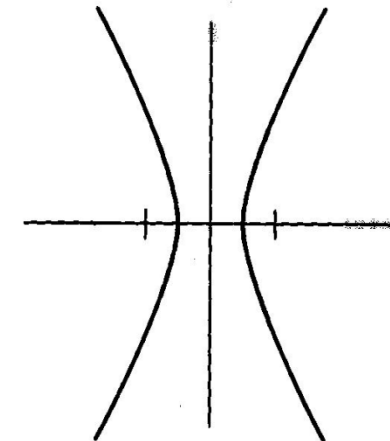
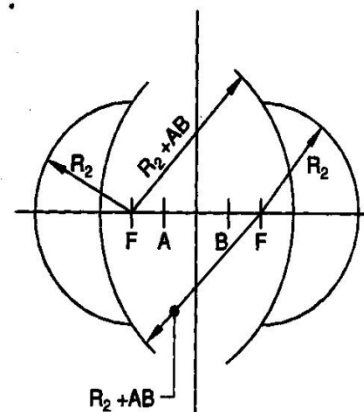

# Roulettes

- **Roulettes are curves generated by the rolling contact of one curve or line on another curve or line, without slipping.**
- **There are various types of roulettes.**
- **The most common types of roulettes used in engineering practice are: Cycloids, Trochoids, and Involutes.**

# Cycloid

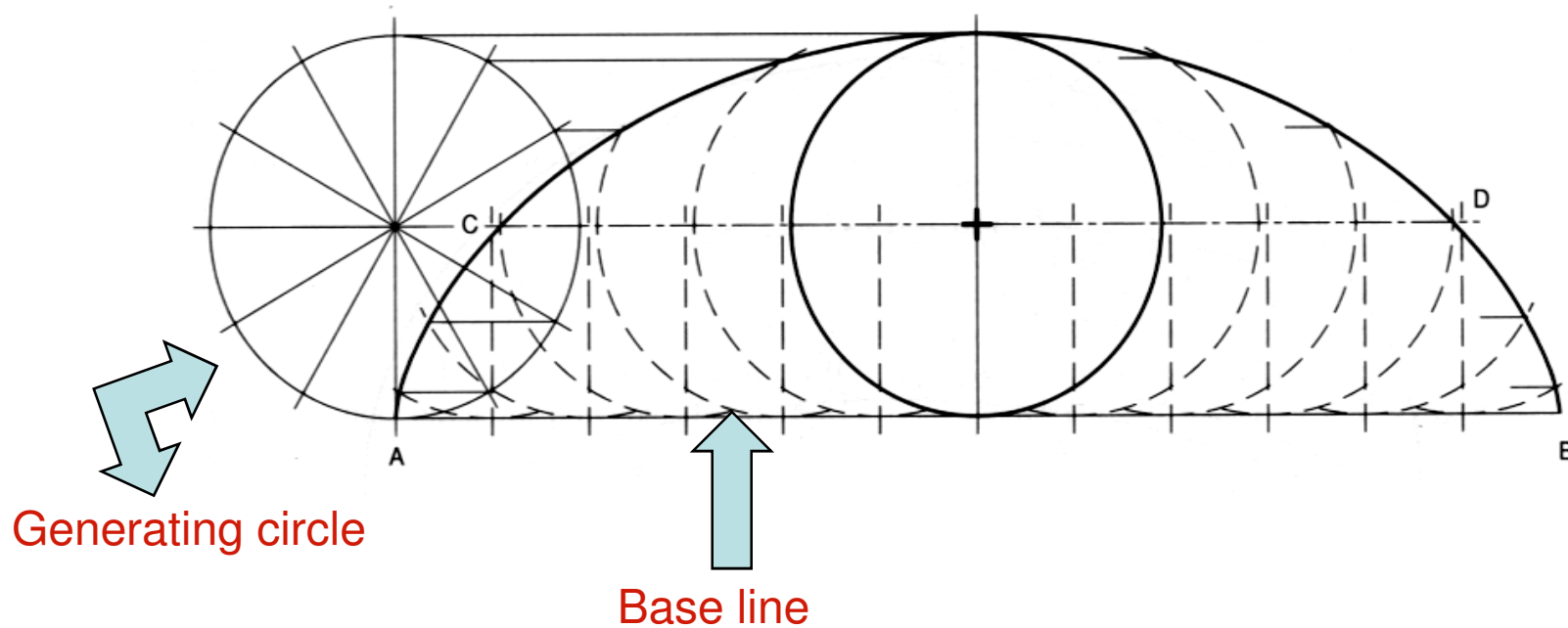

**A Cycloid is generated by a point on the circumference of a circle rolling along a straight line without slipping**

**The rolling circle is called the **Generating circle****

**The straight line is called the **Directing line or Base line****



# Constructing a cycloid

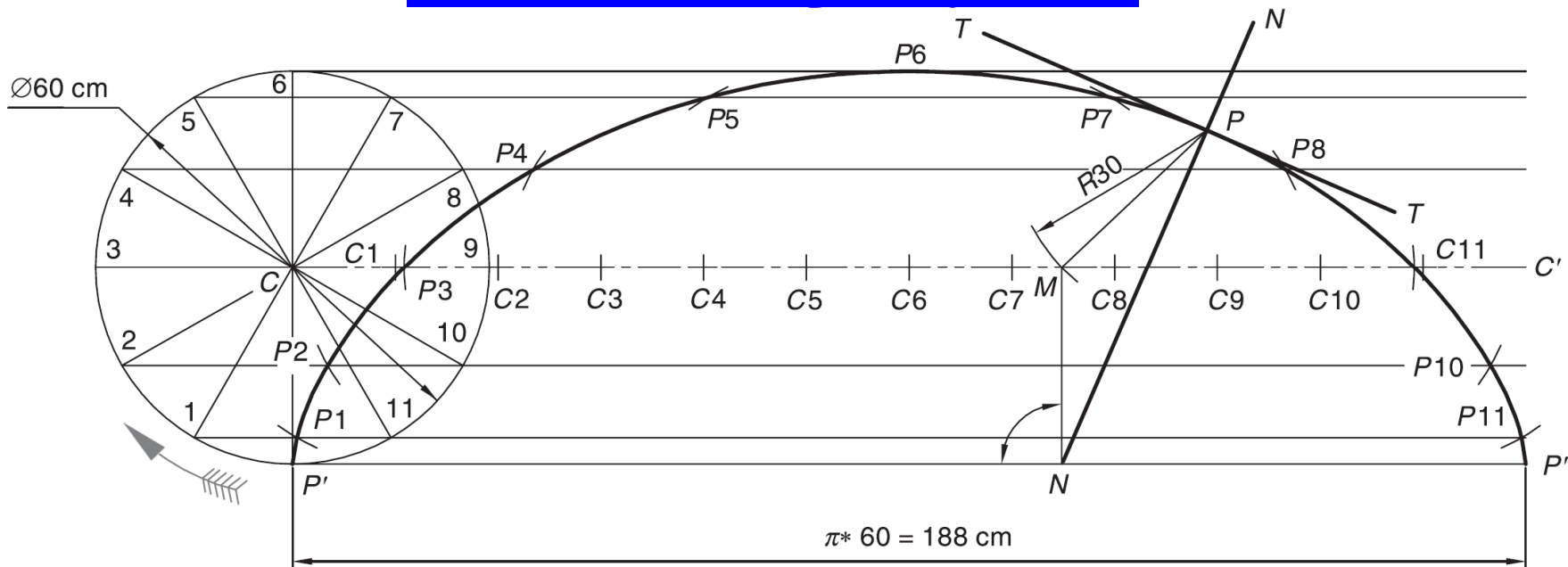

- **Generating circle has its center at C and has a radius of C-P'. Straight line PP' is equal in length to the circumference of the circle and is tangent to the circle at point P'.**
- **Divide the circle into a number of equal segments, such as 12. Number the intersections of the radii and the circle.**
- **From each point of intersection on the circle, draw a construction line parallel to line PP' and extending up to line P'C'.**
- **Divide the line CC' into the same number of equal parts, and number them. Draw vertical lines from each point to intersect the extended horizontal centerline of the circle. Label each point as C1, C2, C3, .... C12.**

## Constructing a cycloid (contd.)

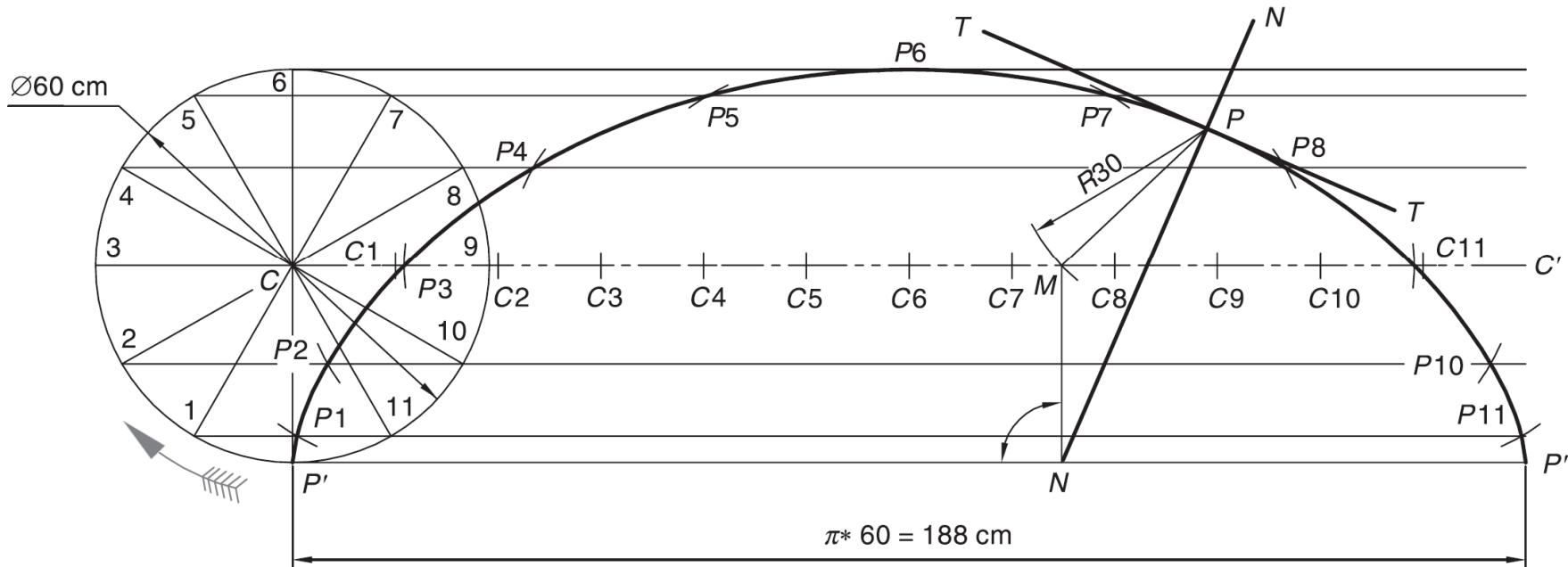

Using point  $C_1$  as the center and radius of the circle  $C-P'$ , draw an arc that intersects the horizontal line extended from point 1 at  $P_1$ . Set the compass at point  $C_2$ , then draw an arc that intersects the horizontal line passing through point 2 at  $P_2$ . Repeat this process using points  $C_3, C_4, \dots, C_{12}$ , to locate points along the horizontal line extended from points 3, 4, 5, etc..

**Draw a smooth curve connecting  $P_1, P_2, P_3$ , etc to form the cycloid**

**Draw normal  $NN$  and Tangent  $TT$**

# Epicycloid

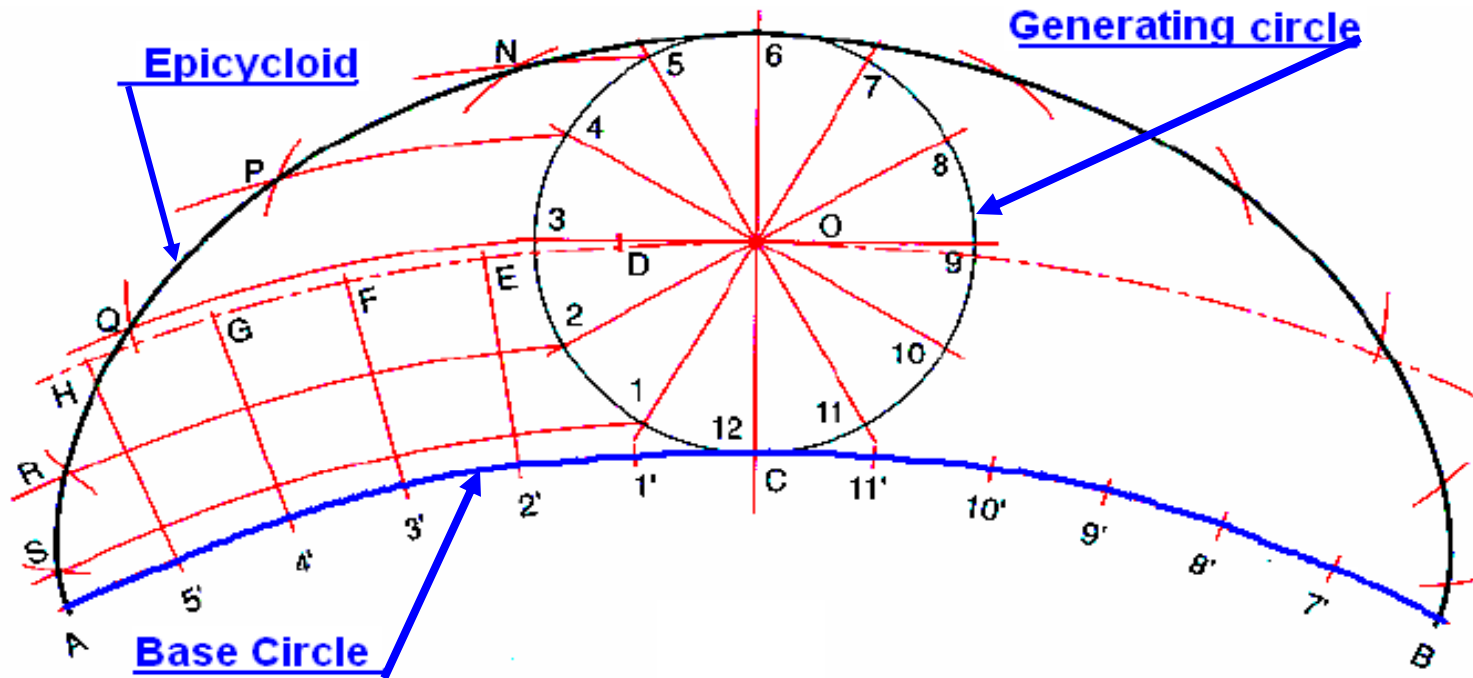

The cycloid is called Epicycloid when the generating circle rolls along another circle outside it.

# Constructing an Epicycloid

1) With **O** as centre and **OC** as radius, draw an arc to represent locus of centre.

2) Divide arc **PQ** in to 12 equal parts and name them as **1', 2', ..., 12'**.

- 3) Join **O1', O2', ...** and produce them to cut the locus of centres at **C1, C2, ....**
- 4) Taking **C1** as centre, and radius equal to 20 mm, draw an arc cutting the arc through 1 at **P1**. Similarly obtain points **P2, P3, ..., P12**.
- 5) Join **P1, P2, ..., P12** With French curve

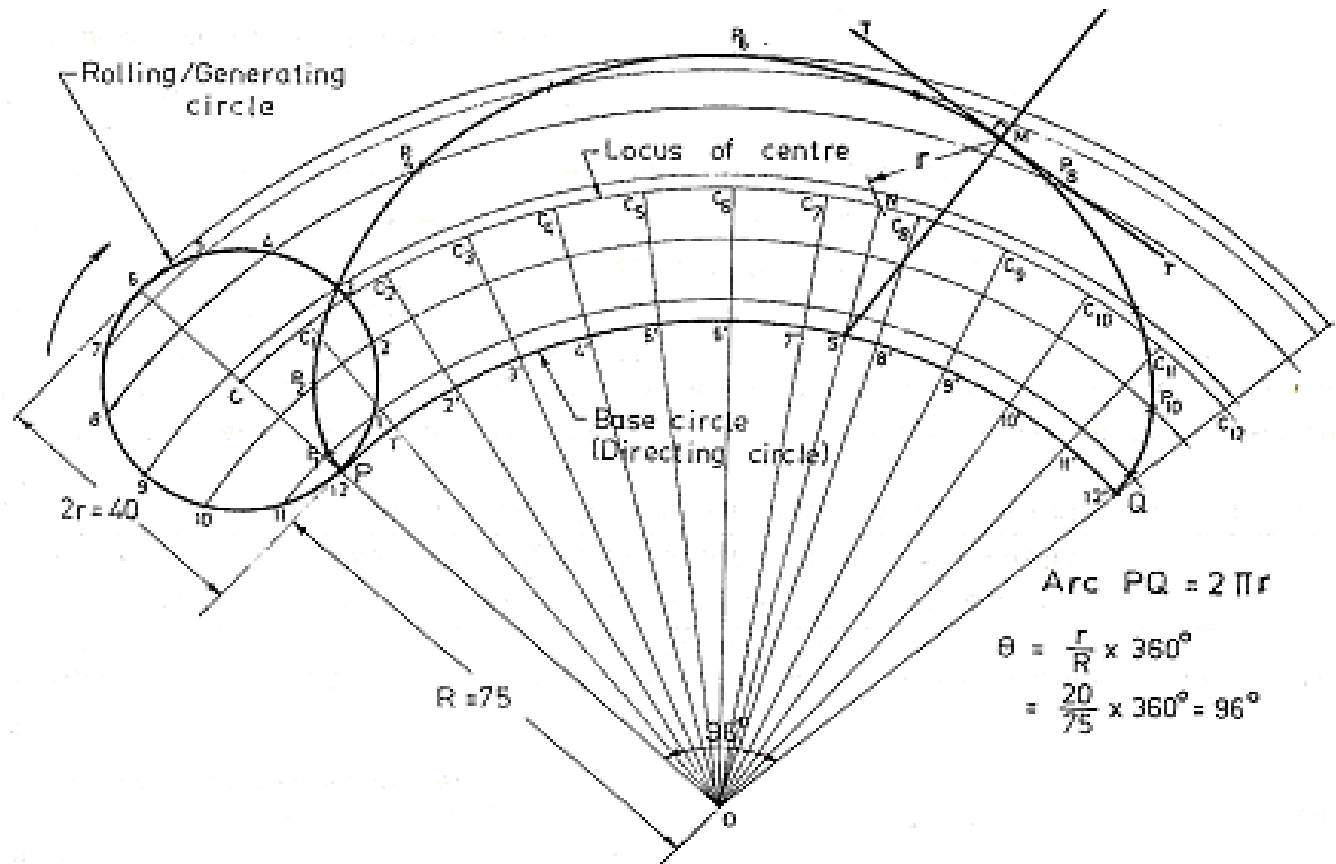

# Hypocycloid

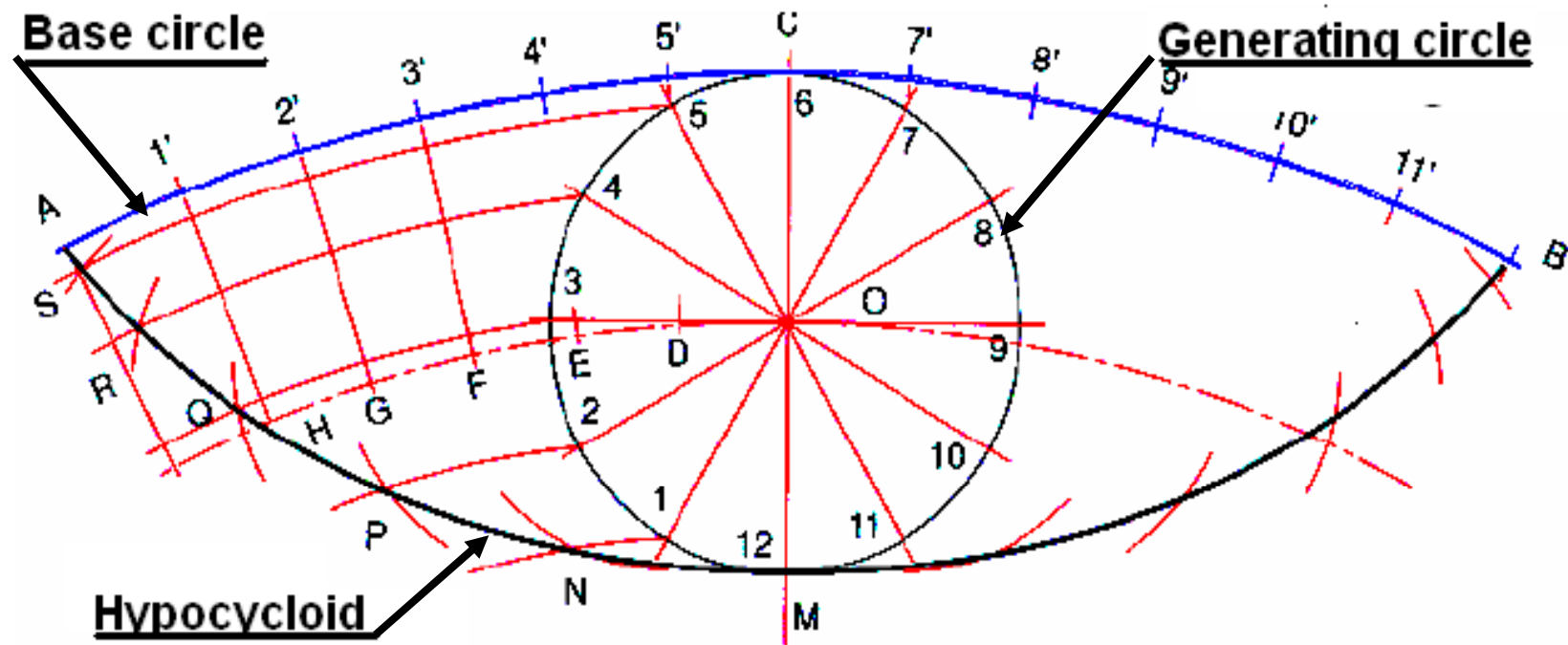

Hypocycloid is obtained when the generating circle rolls along another circle inside it.

# Constructing an Hypocycloid

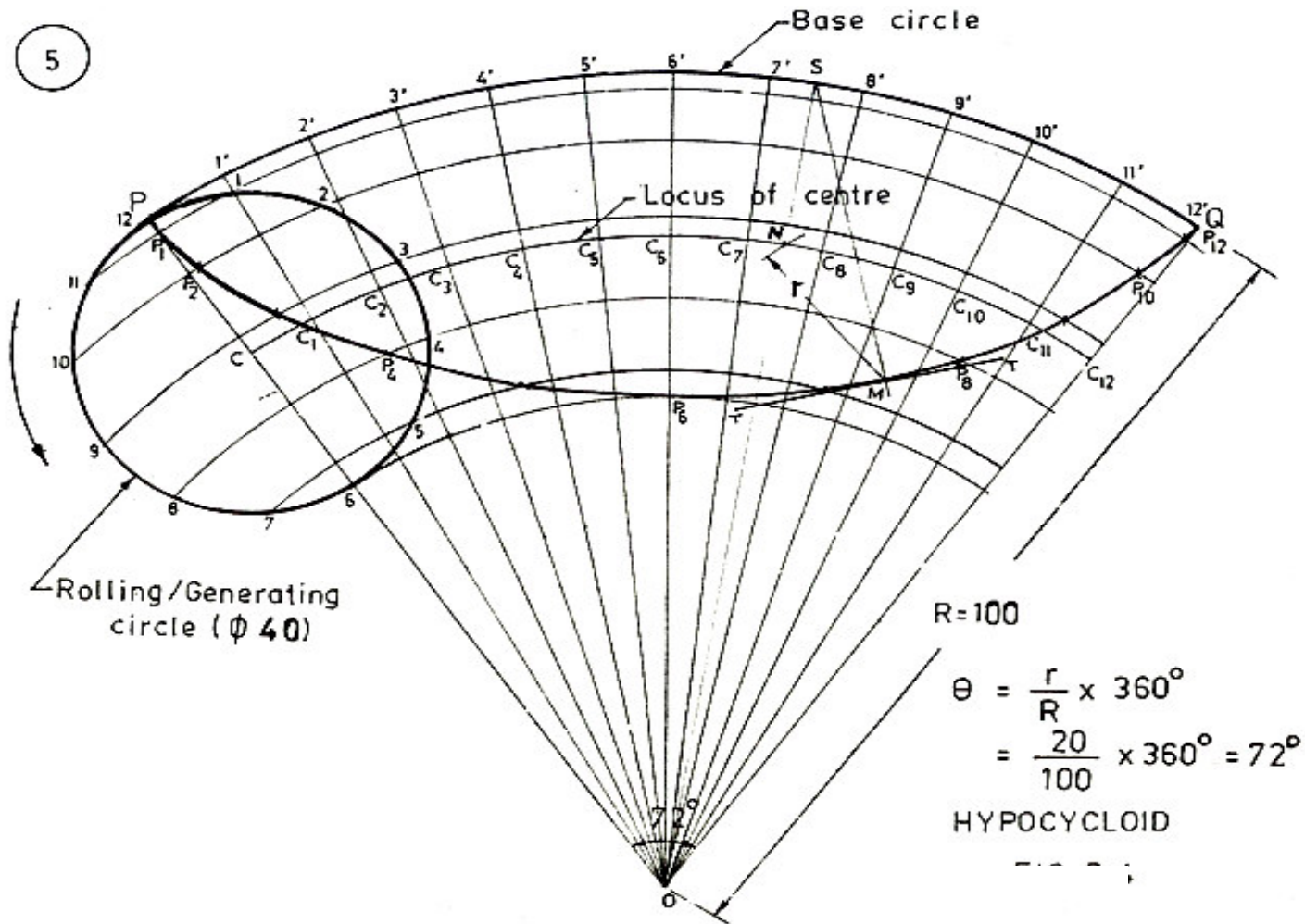

Construction is similar to epicycloid. The generating circle is to be drawn below the base circle

# Trochoid

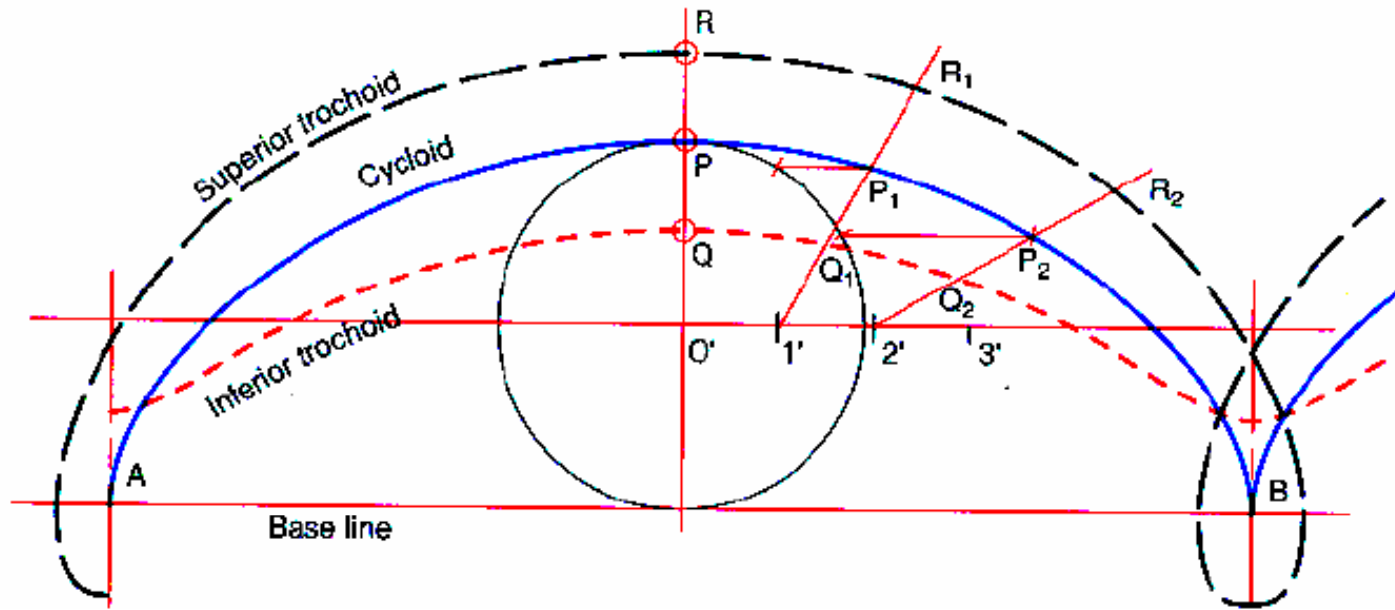

- ***Trochoid*** is a curve generated by a point outside or inside the circle rolling along a straight line.
- If the point is outside the circle the curve obtained is called ***Superior Trochoid***
- If the point is inside the circle, the curve obtained is called ***Inferior Trochoid***

# Classification of Cycloidal curves

	Generating Circle			
		On the directing line	Outside the directing line	Inside the directing line
Generating point	On the generating circle	Cycloid	Epicycloid	Hypocycloid
	Outside the generating circle	Superior trochoid	Superior epitrochoid	Superior Hypotrochoid
	Inside the generating circle	Inferior trochoid	Inferior epitrochoid	Inferior hypotrochoid





# Construction of Involute of circle

**Draw the circle with  $c$  as center and  $CP$  as radius.**

**Draw line  $PQ = 2\pi CP$ , tangent to the circle at  $P$**

**Divide the circle into 12 equal parts. Number them as 1, 2...**

**Divide the line  $PQ$  into 12 equal parts and number as  $1', 2' \dots$**

**Draw tangents to the circle at 1, 2, 3....**

**Locate points  $P_1, P_2$  such that  $1-P_1 = P_1', 2-P_2 = P_2' \dots$**

**Join  $P, P_1, P_2 \dots$**

**The tangent to the circle at any point on it is always normal to the its involute.**

**Join  $CN$ . Draw a semicircle with  $CN$  as diameter, cutting the circle at  $M$ .  $MN$  is the normal.**

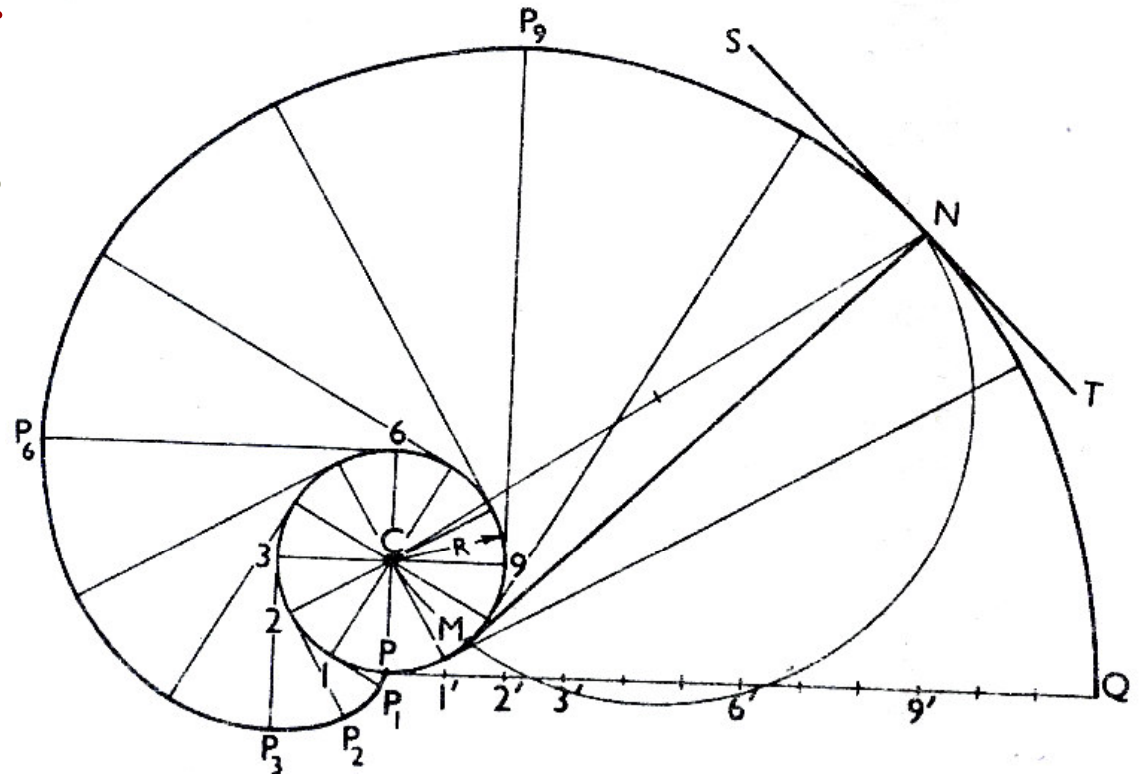

# **ME 111: Engineering Drawing**

## **Theory of Projections**

**Indian Institute of Technology Guwahati  
Guwahati – 781039**

# Projection theory

**3-D objects and structures are represented graphically on 2-D media.**

**All projection theory are based on two variables:**

- **Line of sight**
- **Plane of projection.**

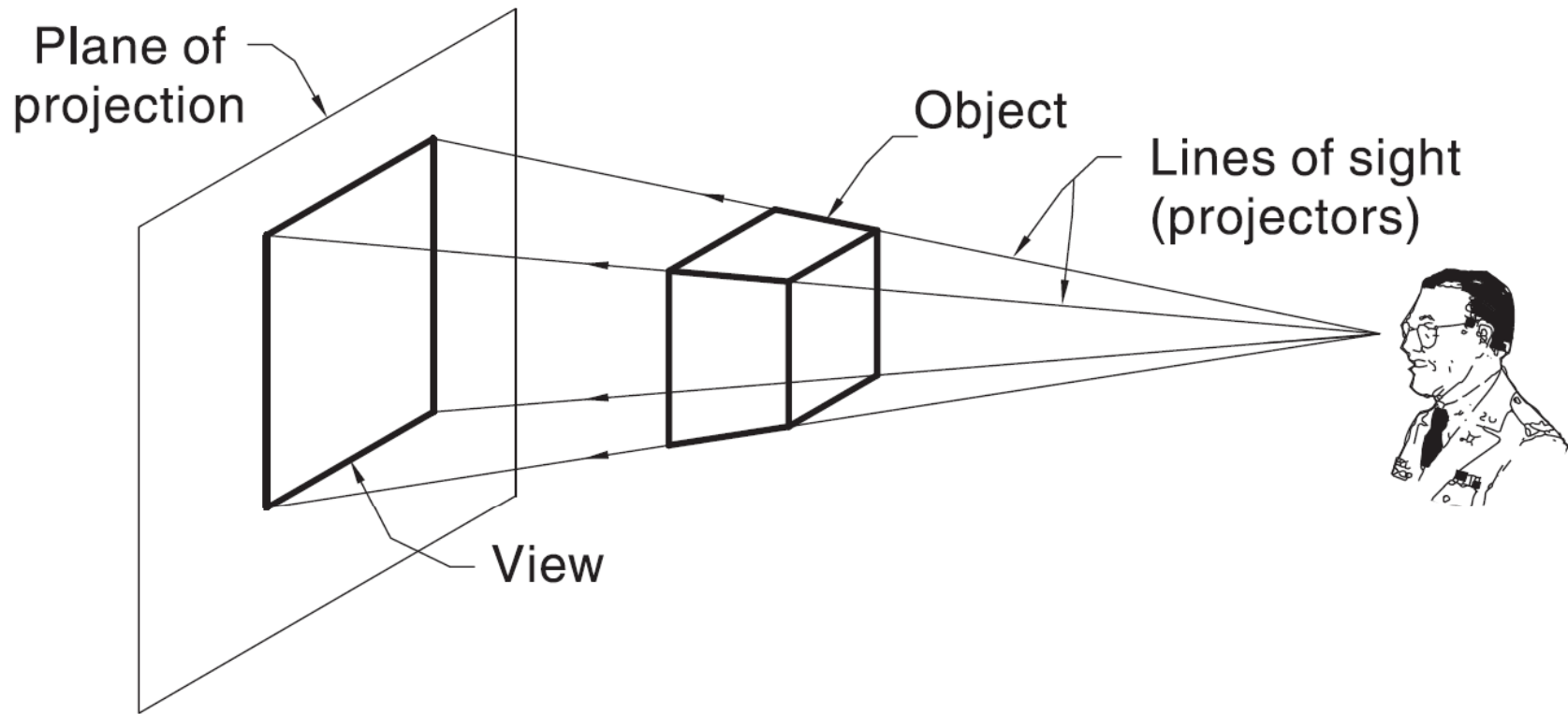

**Projection system**

# **Plane of Projection**

**A plane of projection (i.e, an image or picture plane) is an imaginary flat plane upon which the image created by the line of sight is projected.**

**The image is produced by connecting the points where the lines of sight pierce the projection plane. In effect, 3-D object is transformed into a 2-D representation, also called projections.**

**The paper or computer screen on which a drawing is created is a plane of projection**

# Projection Methods

Projection methods are very important techniques in engineering drawing.

Two projection methods used are:

- Perspective and
- Parallel.



Nonparallel lines of sight radiating from a point

**In perspective projection, all lines of sight start at a single point.**

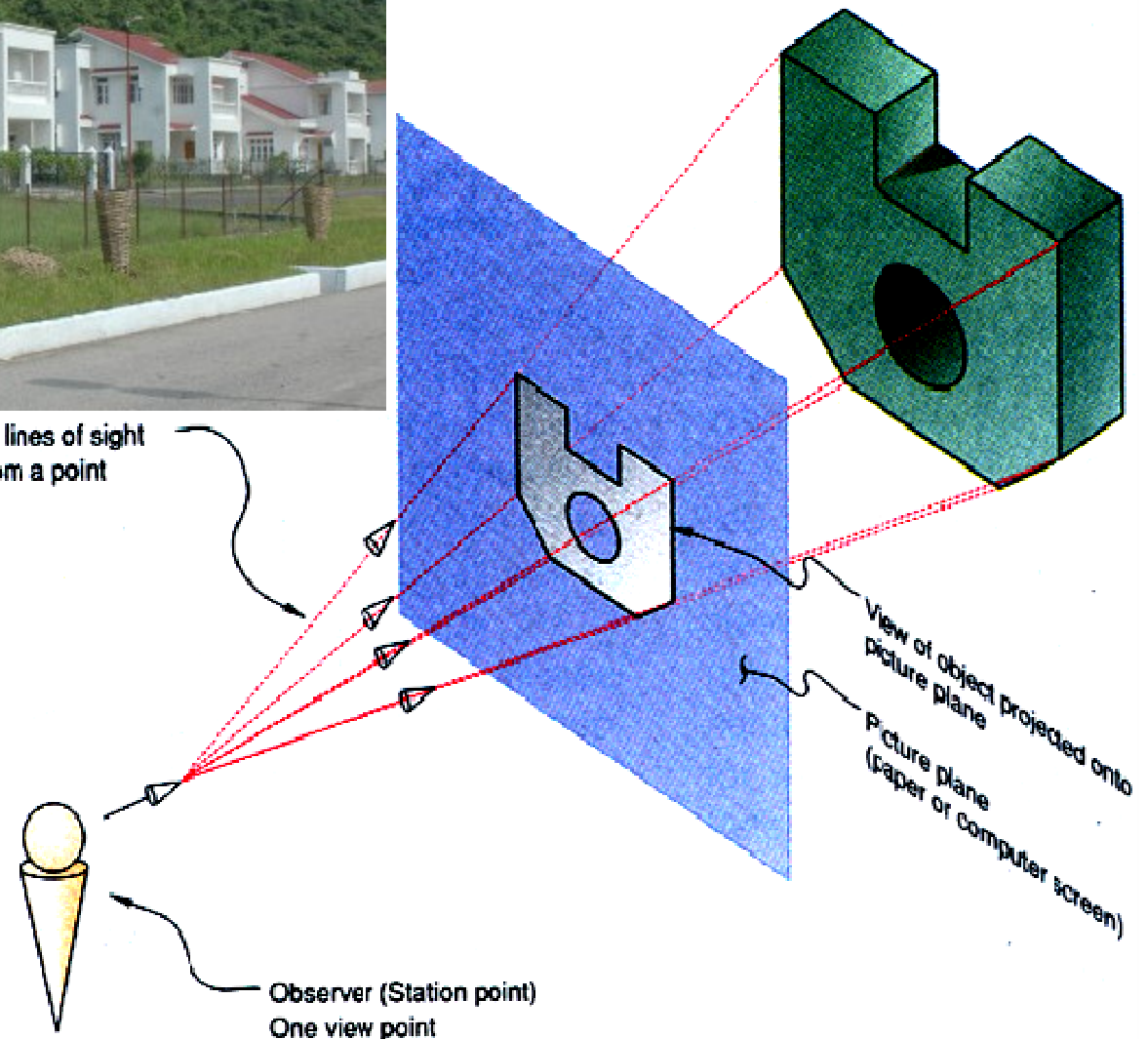



In parallel projection, all lines of sight are parallel.

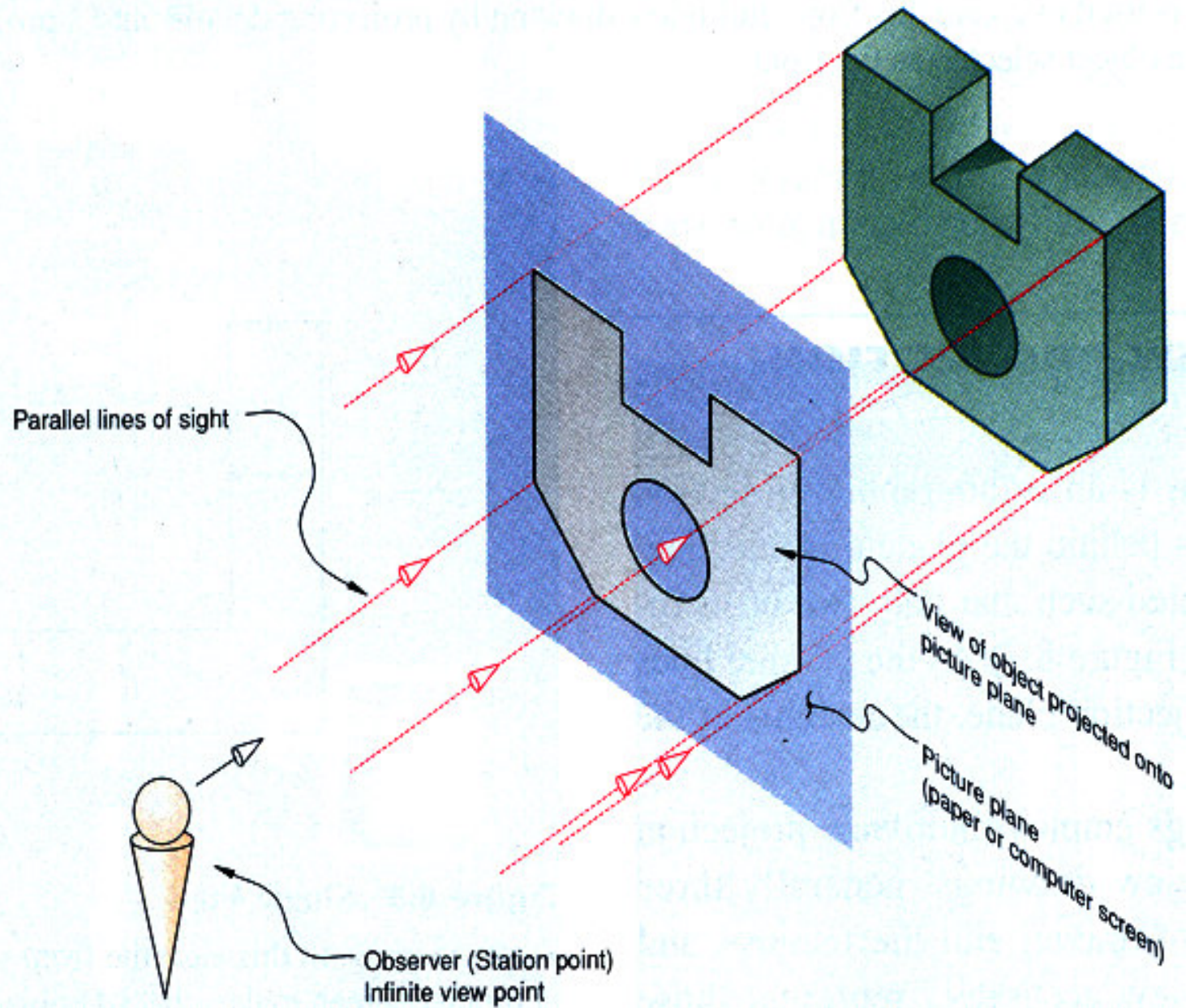

# **Parallel vs Perspective Projection**

## **Parallel projection**

**Distance from the observer to the object is infinite, projection lines are parallel – object is positioned at infinity.**

**Less realistic but easier to draw.**

## **Perspective projection**

**Distance from the observer to the object is finite and the object is viewed from a single point – projectors are not parallel.**

**Perspective projections mimic what the human eyes see, however, they are difficult to draw.**