

**VEER SURENDRA SAI UNIVERSITY OF TECHNOLOGY
BURLA, ODISHA, INDIA**

DEPARTMENT OF PRODUCTION ENGINEERING

Lecture Notes on

ADVANCED CASTING AND WELDING (ACW)

COURSE CODE: BMS 405: PE-I

7th Semester B. Tech in Production Engineering

BMS 405: PE-I: ADVANCED CASTING AND WELDING (3-1-0): Syllabus

Module-I

Casting processes: Classification, Metal mould casting processes, advanced casting processes, investment casting, Rheocasting, mould and core making materials and their characteristics.

[04 Lectures]

Technology of Selected casting Processes: Clay bonded, synthetic resin bonded, inorganic material bonded mould and core making, sand additives, mould coating, continuous casting process, centrifugal casting process.

[06 Lectures]

Module-II

Casting defects, inspection, diagnosis and rectification, mechanization and automation in foundries, use of robots, casting design, near net shape casting, pollution control, energy and waste management in foundries.

[04 Lectures]

Physics of welding arc, characteristics of arc, modes of metal transfer, welding fluxes, electrode coating, classification of electrode, characteristics of welding power source, pulsed and inverter type power source, power source for resistance welding, weldability, weldability tests, Weldability of cast iron, Plain carbon steel, Determination of preheating temperature, Stainless steel, use of Scheffler' s diagram.

[10 Lectures]

Module-III

Heat flow in welding, significance, theory of heat flow, cooling rate determination, selection of welding parameters based on heat flow analysis, residual stress and its measurement, types and control of distortion.

[08 Lectures]

Module-III

Analysis of fatigue of welded joint, fracture and toughness testing and its application on welded joint, automated welded joint, microprocessor based of control resistance and arc welding, quality assurance in welding, effects of welding fumes on environment.

[08 Lectures]

TEXT BOOK(S):

1. Principle of Metal Casting- Heine, R.W. Loper ,C. Philip and C.R.Rosenthal, McGraw Hill.
2. Principle of Metal Casting- P.L.Jain, TMH
3. Manufacturing Technology- P.N.Rao, TMH
4. Welding Engineering and Technology- R.S. Parmar Khanna publisher

REFERENCE(S):

1. Metallurgy of Welding Technology-D. Seferian, Chapman & Hall
2. Welding and Welding Technology- R.Little, TMH.

Module-I

Casting processes: Classification, Metal mould casting processes, advanced casting processes, investment casting, Rheocasting, mould and core making materials and their characteristics. Technology of Selected casting Processes: Clay bonded, synthetic resin bonded, inorganic material bonded mould and core making, sand additives, mould coating, continuous casting process, centrifugal casting process.

1. Introduction to Casting processes

Metal casting process begins by creating a mold, which is the 'reverse' shape of the part we need. The mould is made from a refractory material, for example, sand. The metal is heated in an oven until it melts, and the molten metal is poured into the mould cavity. The liquid takes the shape of cavity, which is the shape of the part. It is cooled until it solidifies. Finally, the solidified metal part is removed from the mould.

A large number of metal components in designs we use every day are made by casting.

The reasons for this include:

- (a) Casting can produce very complex geometry parts with internal cavities and hollow sections
- (b) It can be used to make small (few hundred grams) to very large size parts (thousands of kilograms)
- (c) It is economical, with very little wastage: the extra metal in each casting is re-melted and re-used
- (d) Cast metal is isotropic – it has the same physical/mechanical properties along any direction

Common examples: door handles, locks, the outer casing or housing for motors, pumps, etc., wheels of many cars. Casting is also heavily used in the toy industry to make parts, e.g. toy cars, planes, and so on. Typical metal cast parts are shown in Fig.1



Fig.1: Typical metal cast parts

Table 1 summarizes different types of castings, their advantages, disadvantages and examples.

Table 1

Process	Advantages	Disadvantages	Examples
Sand	Wide range of metals, sizes, shapes, low cost	poor finish, wide tolerance	engine blocks, cylinder heads
Shell mold	better accuracy, finish, higher production rate	limited part size	connecting rods, gear housings
Expendable pattern	Wide range of metals, sizes, shapes	patterns have low strength	cylinder heads, brake components
Plaster mold	complex shapes, good surface finish	non-ferrous metals, low production rate	prototypes of mechanical parts
Ceramic mold	complex shapes, high accuracy, good finish	small sizes	impellers, injection mold tooling
Investment	complex shapes, excellent finish	small parts, expensive	jewellery
Permanent mold	good finish, low porosity, high production rate	Costly mold, simpler shapes only	gears, gear housings
Die	Excellent dimensional accuracy, high production rate	costly dies, small parts, non-ferrous metals	precision gears, camera bodies, car wheels
Centrifugal	Large cylindrical parts, good quality	Expensive, limited shapes	pipes, boilers, flywheels

1.1 Sand Casting: Sand casting uses natural or synthetic sand (lake sand) which is mostly refractory material called silica (SiO_2). The sand grains must be small enough so that it can be packed densely; however, the grains must be large enough to allow gasses formed during the metal pouring to escape through the pores. Larger sized molds use green sand (mixture of sand, clay and some water). Sand can be re-used, and excess metal poured is cut-off and re-used also.

Typical sand molds have the following parts (Fig 2):

- The mold is made of two parts, the top half is called the **cope**, and bottom part is the **drag**.
- The liquid flows into the gap between the two parts, called the mold **cavity**. The geometry of the cavity is created by the use of a wooden shape, called the **pattern**. The shape of the patterns is (almost) identical to the shape of the part we need to make.
- A funnel shaped cavity; the top of the funnel is the **pouring cup**; the pipe-shaped neck of the funnel is the **sprue**– the liquid metal is poured into the pouring cup, and flows down the sprue.
- The **runners** are the horizontal hollow channels that connect the bottom of the sprue to the mould cavity. The region where any runner joins with the cavity is called the **gate**.

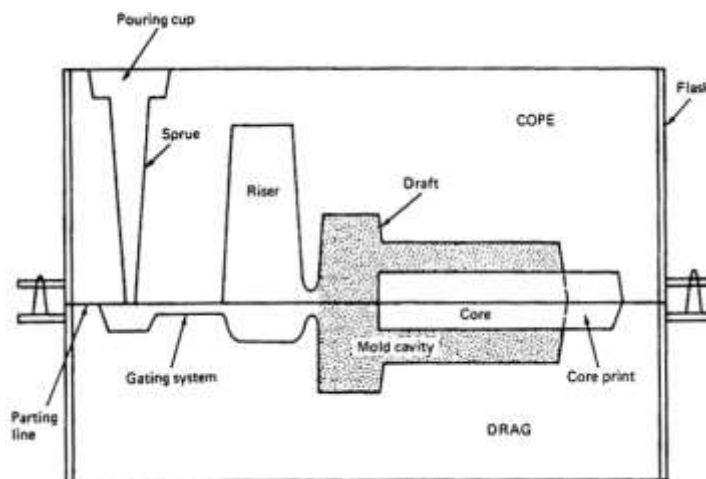


Fig 2: Schematic representation of a typical sand mould cross-section

Some extra cavities are made connecting to the top surface of the mold. Excess metal poured into the mould flows into these cavities, called **risers**. They act as reservoirs; as

the metal solidifies inside the cavity, it shrinks, and the extra metal from the risers flows back down to avoid holes in the cast part.

- **Vents** are narrow holes connecting the cavity to the atmosphere to allow gasses and the air in the cavity to escape.
- **Cores:** Many cast parts have interior holes (hollow parts), or other cavities in their shape that are not directly accessible from either piece of the mold. Such interior surfaces are generated by inserts called **cores**. Cores are made by baking sand with some binder so that they can retain their shape when handled. The mold is assembled by placing the core into the cavity of the drag, and then placing the cope on top, and locking the mold. After the casting is done, the sand is shaken off, and the core is pulled away and usually broken off.

Gating System: Channel through which molten metal flows into cavity from outside of mold consists of a downsprue, through which metal enters a runner leading to the main cavity. At top of down-sprue, a pouring cup is often used to minimize splash and turbulence as the metal flows into down-sprue.

1.2 Shell-mold Casting:

In this process the moulds and cores are prepared by mixing the dry free flowing sand with thermosetting resins and then heating the aggregate (mixture of fine sand (100-150 mesh) and thermosetting resins) against a heated metal plate. Due to the heat, the resin cures, which causes the sand grains to get bonded with each other and it forms a hard shell around the metallic pattern. The inside portion of the shell is the exact replica of the pattern against which the sand aggregate is placed before heating. The shape and dimension of the inside portion of the shell thus formed is exactly the same as that of the pattern. If the pattern is of two pieces then the other half of the shell is also prepared the same way. Two halves of the shells prepared are placed together after inserting the core, if any, to make the assembly of the mould. The assembly of the shell is then placed in a molding flask and backing material is placed all around the shell mould assembly to give its assembly the sufficient strength. Now the shell mould is fully ready for pouring the liquid metal.

Sand

The dry free flowing sand used in the shell mould must be completely free of clay content. The grain size of the sand used in shell molding is generally in the range of 100-150 meshes, as the shell casting process is recommended for castings that require good surface finish. However, depending on the requirement of surface finish of the final casting, the grain size of the sand can be ascertained. Also, if the grain size is very fine, it requires large amount of resins, making it expensive.

Resin and Catalyst

The resins most widely used, are the phenol formaldehyde resins, which are thermosetting in nature. Combined with sand, they give very high strength and resistance to heat. The resin initially has excess phenol and acts like a thermoplastic material. In order to develop the thermosetting properties of the resin, the coating of the sand is done with resin and a catalyst (Hexa-methylene-tetramine, known as Hexa). The measure of resin is 4-6% of sand by weight, the catalysts 14-16% of sand by weight. The curing temperature of the resin along with the catalysts is around 150o C and the time required for complete curing is 50 – 65 seconds. The sand composition to be used in making various casting of different materials can be seen from the relevant standards.

The resins available are of water-bourn, flake, or the granular types. The specifications of liquid, flakes or powder resins can be obtained from IS 8246-1976, IS 11266-1985, and IS 10979-1981 respectively.

Shell-mold casting yields better surface quality and tolerances. The process is described as follows:

- The 2-piece pattern is made of metal (e.g. aluminum or steel), it is heated to between 175°C-370°C, and coated with a lubricant, e.g. silicone spray.
- Each heated half-pattern is covered with a mixture of sand and a thermoset resin/epoxy binder. The binder glues a layer of sand to the pattern, forming a shell. The process may be repeated to get a thicker shell (Fig 3).
- The assembly is baked to cure it. 6

- The patterns are removed, and the two half-shells joined together to form the mold; metal is poured into the mold.
- When the metal solidifies, the shell is broken to get the part.

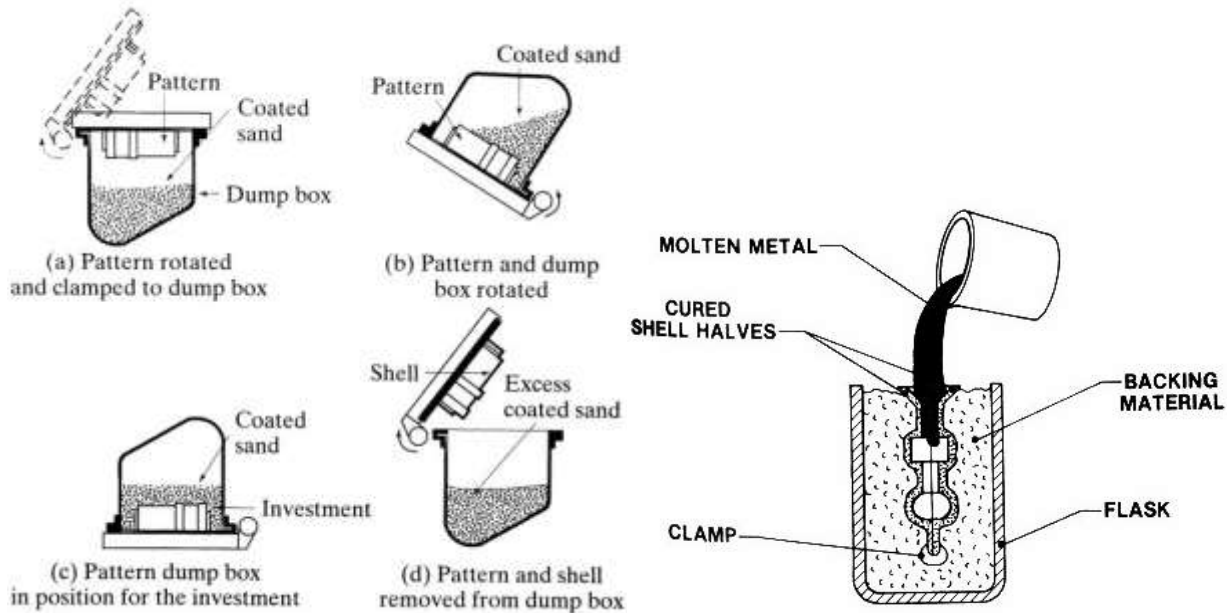


Fig 3: Making the shell-mold and Shell mold casting

1.3 Expendable-pattern casting (lost foam process)

The pattern used in this process is made from polystyrene (this is the light, white packaging material which is used to pack electronics inside the boxes). Polystyrene foam is 95% air bubbles, and the material itself evaporates when the liquid metal is poured on it.

The pattern itself is made by molding – the polystyrene beads and pentane are put inside an aluminum mold, and heated; it expands to fill the mold, and takes the shape of the cavity. The pattern is removed, and used for the casting process, as follows:

- The pattern is dipped in slurry of water and clay (or other refractory grains); it is dried to get a hard shell around the pattern.
- The shell-covered pattern is placed in a container with sand for support, and liquid metal is poured from a hole on top.
- The foam evaporates as the metal fills the shell; upon cooling and solidification, the part is removed by breaking the shell. 7

The process is useful since it is very cheap, and yields good surface finish and complex geometry. There are no runners, risers, gating or parting lines – thus the design process is

simplified. The process is used to manufacture crank-shafts for engines, aluminum engine blocks, manifolds etc.

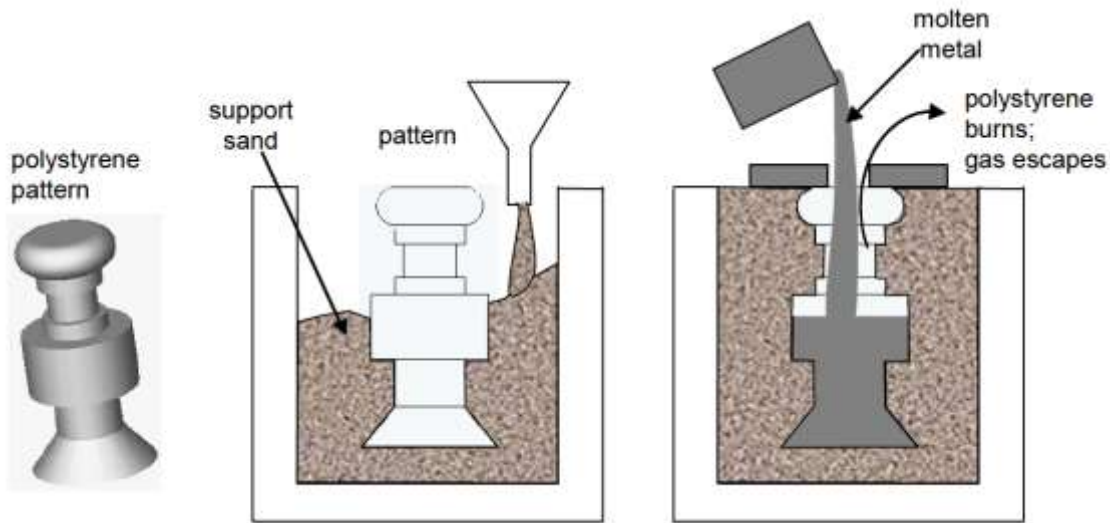


Fig 4: Expendable mold casting

Details

The minimum wall thickness for a full-mold casting is 2.5 mm (0.10 in). Typical dimensional tolerances are 0.3% and typical surface finishes are from 2.5 to 25 μm (100 to 1000 μin) RMS. The size range is from 400 g (0.88 lb) to several tonnes (tons).

Full-mold casting is often used to produce cylinder heads, engine blocks, pump housings, automotive brake components, and manifolds. Commonly employed materials include aluminium, iron, steel, nickel alloys, and copper alloys.

Advantages and disadvantages

This casting process is advantageous for very complex castings that would regularly require cores. It is also dimensionally accurate, requires no draft, and has no parting lines so no flash is formed. As compared to investment casting, it is cheaper because it is a simpler process and the foam is cheaper than the wax. Risers are not usually required due to the nature of the process; because the molten metal vaporizes the foam the first metal into the mold cools more quickly than the rest, which results in natural directional solidification.

The two main disadvantages are that pattern costs can be high for low volume applications and the patterns are easily damaged or distorted due to their low strength. If a die is used to create the patterns there is a large initial cost.

1.4 Full Mold Process / Lost Foam Process / Evaporative Pattern Casting Process

The use of foam patterns for metal casting was patented by H.F. Shroyer on April 15, 1958. In Shroyer's patent, a pattern was machined from a block of expanded polystyrene (EPS) and supported by bonded sand during pouring. This process is known as the full mold process. With the full mold process, the pattern is usually machined from an EPS block and is used to make primarily large, one-of-a kind castings. The full mold process was originally known as the lost foam process. However, current patents have required that the generic term for the process be full mold.

In 1964, M.C. Flemmings used unbounded sand with the process. This is known today as lost foam casting (LFC). With LFC, the foam pattern is molded from polystyrene beads. LFC is differentiated from full mold by the use of unbounded sand (LFC) as opposed to bonded sand (full mold process).

Foam casting techniques have been referred to by a variety of generic and proprietary names. Among these are lost foam, evaporative pattern casting, and cavity less casting, evaporative foam casting, and full mold casting.

In this method, the pattern, complete with gates and risers, is prepared from expanded polystyrene. This pattern is embedded in a no bake type of sand. While the pattern is inside the mold, molten metal is poured through the sprue. The heat of the metal is sufficient to gasify the pattern and progressive displacement of pattern material by the molten metal takes place.

The EPC process is an economical method for producing complex, close-tolerance castings using an expandable polystyrene pattern and unbonded sand. Expandable polystyrene is a thermoplastic material that can be molded into a variety of complex,

rigid shapes. The EPC process involves attaching expandable polystyrene patterns to an expandable polystyrene gating system and applying a refractory coating to the entire assembly. After the coating has dried, the foam pattern assembly is positioned on loose dry sand in a vented flask. Additional sand is then added while the flask is vibrated until the pattern assembly is completely embedded in sand. Molten metal is poured into the sprue, vaporizing the foam polystyrene, perfectly reproducing the pattern.

1.5 *Plaster-mold casting*

The mold is made by mixing plaster of paris (CaSO_4) with talc and silica flour; this is a fine white powder, which, when mixed with water gets a clay-like consistency and can be shaped around the pattern (it is the same material used to make casts for people if they fracture a bone). The plaster cast can be finished to yield very good surface finish and dimensional accuracy. However, it is relatively soft and not strong enough at temperature above 1200°C , so this method is mainly used to make castings from non-ferrous metals, e.g. zinc, copper, aluminum, and magnesium.

Since plaster has lower thermal conductivity, the casting cools slowly, and therefore has more uniform grain structure (i.e. less warpage, less residual stresses).

1.6 *Ceramic mold casting*

Similar to plaster-mold casting, except that ceramic material is used (e.g. silica or powdered Zircon ZrSiO_4). Ceramics are refractory (e.g. the clay hotpot used in Chinese restaurants to cook some dishes), and also have higher strength than plaster.

- The ceramic slurry forms a shell over the pattern;
- It is dried in a low temperature oven, and the pattern is removed
- Then it is backed by clay for strength, and baked in a high temperature oven to burn off any volatile substances.
- The metal is cast same as in plaster casting.

This process can be used to make very good quality castings of steel or even stainless steel; it is used for parts such as impeller blades (for turbines, pumps, or rotors for motor-boats).

1.7 Investment casting (*lost wax process*)

The investment casting process, which is commonly referred to as the “lost wax method”, originated in and around the fourth millennium B.C. It is evidenced through the architectural works found in the form of idols, pectorals and jewelry in remains of the ancient Egypt and Mesopotamia. The investment casting process initiates with the production of wax replicas or patterns of the required shape of castings. Each and every casting requires a pattern to be produced. Wax or polystyrene is made used as the injecting material. The assembly of large number of patterns are made and attached to a wax sprue centrally. Metallic dies are used to prepare the patterns. The pattern is immersed in refractory slurry which completely surrounds it and gets set at room temperature forming the mold. The mold is further heated, so that the pattern melts and flows out, leaving the required cavity behind. After heating, the mold gets further hardened and molten metal is poured while it is still hot. After the casting gets solidified, the mold is broken and it is taken out.

The basic steps of the investment casting process are as shown in Fig 5:

1. Preparing the heat-disposable wax, plastic or polystyrene patterns in a die.
2. Assembly of the prepared patterns onto a gating system
3. “Investing,” (covering) the pattern assembly with a refractory slurry which builds the shell.
4. Melting the pattern assembly (burning out the wax) by firing, for removing the traces of the pattern material
5. The metal in molten state is poured into the formed mold.
6. Once the metal solidifies, the shell is removed (knocked out).
7. Fettling (cutting off) of the pouring basin and gates followed by finishing operations to get the desired dimensional tolerances and finish.

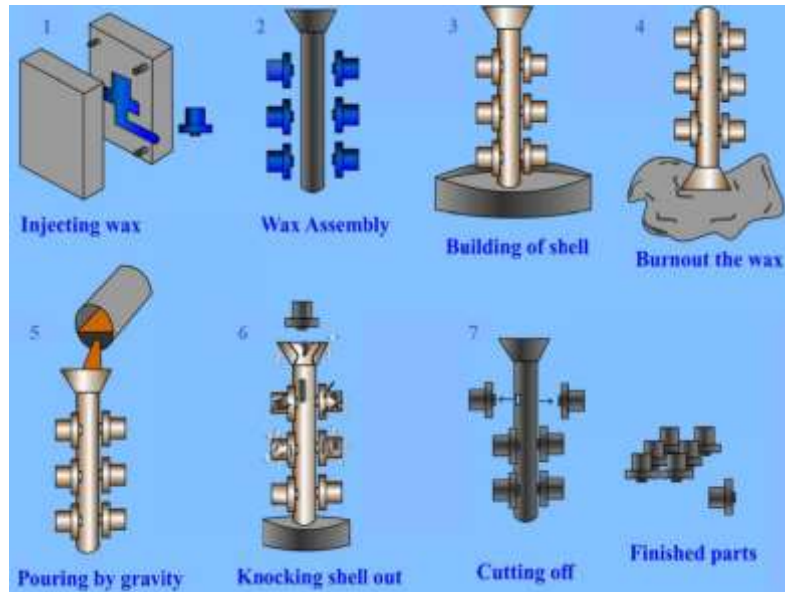


Fig 5: The Basic Steps of the Investment Casting Process

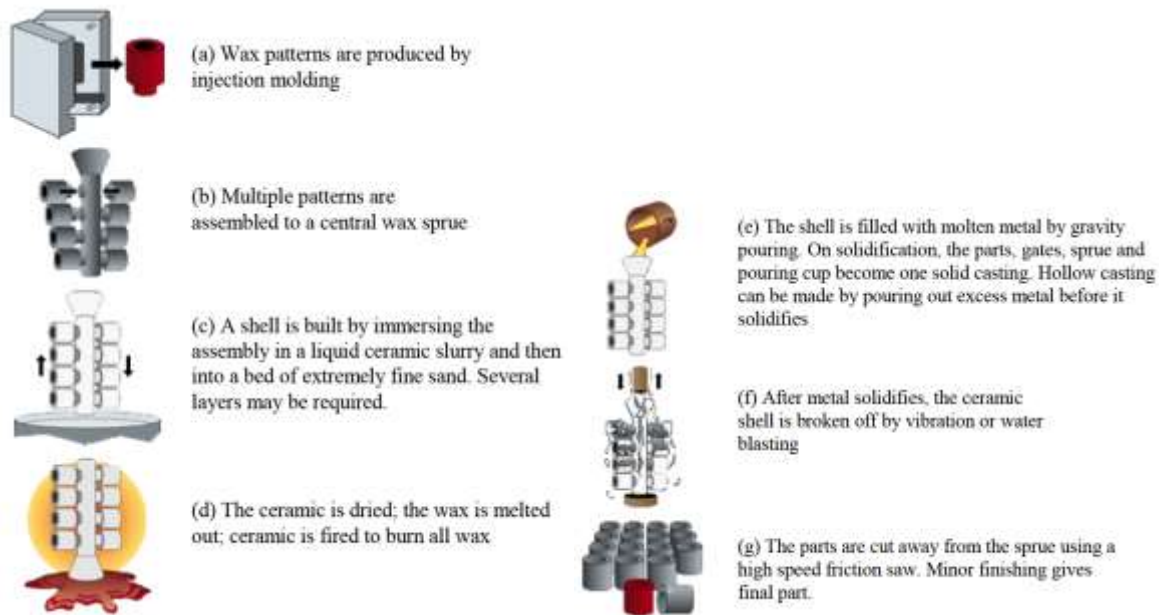


Fig 5a: Steps in the investment casting process

This is an old process, and has been used since ancient times to make jewellery – therefore it is of great importance to HK. It is also used to make other small (few grams, though it can be used for parts up to a few kilograms). The steps of this process are shown in the Fig 5a.

An advantage of this process is that the wax can carry very fine details – so the process not only gives good dimensional tolerances, but also excellent surface finish; in fact, almost any surface texture as well as logos etc. can be reproduced with very high level of detail.

1.8 Vacuum casting

This process is also called counter-gravity casting. It is basically the same process as investment casting, except for the step of filling the mold. In this case, the material is sucked upwards into the mould by a vacuum pump. The figure 6 below shows the basic idea – notice how the mold appears in an inverted position from the usual casting process, and is lowered into the flask with the molten metal (Fig 6).

One advantage of vacuum casting is that by releasing the pressure a short time after the mold is filled, we can release the un-solidified metal back into the flask. This allows us to create hollow castings. Since most of the heat is conducted away from the surface between the mold and the metal, therefore the portion of the metal closest to the mold surface always solidifies first; the solid front travels inwards into the cavity. Thus, if the liquid is drained a very short time after the filling, then we get a very thin walled hollow object, etc. (Fig 7).

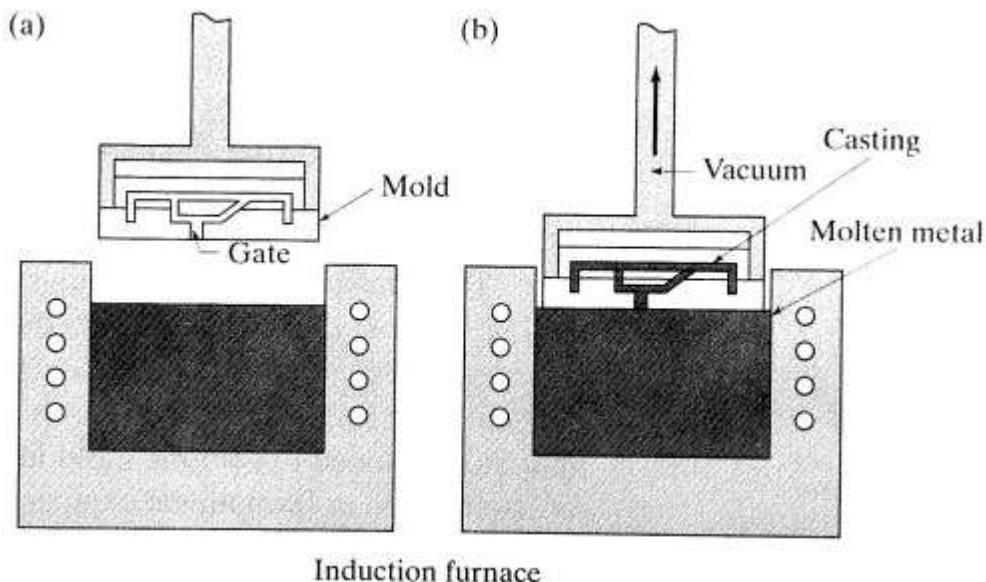


Fig 6: Vacuum casting

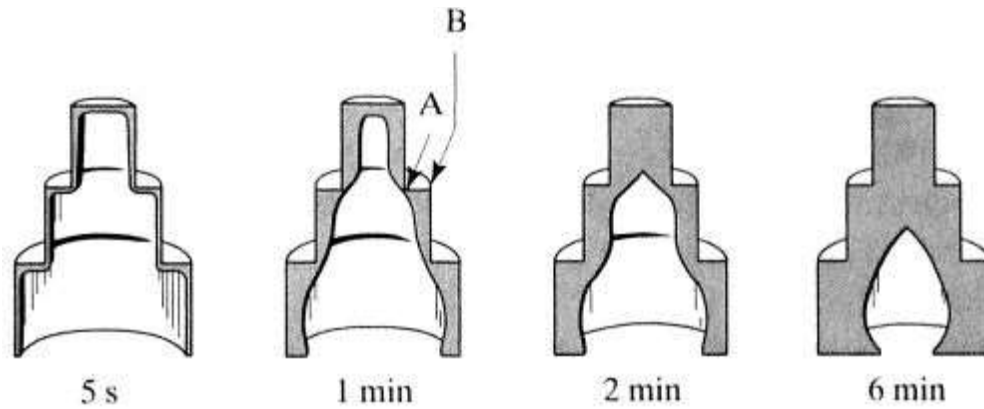


Fig 7: Draining out metal before solidification yields hollow castings

1.9 Permanent mold casting

Here, the two halves of the mold are made of metal, usually cast iron, steel, or refractory alloys. The cavity, including the runners and gating system are machined into the mold halves. For hollow parts, either permanent cores (made of metal) or sand-bonded ones may be used, depending on whether the core can be extracted from the part without damage after casting. The surface of the mold is coated with clay or other hard refractory material – this improves the life of the mold. Before molding, the surface is covered with a spray of graphite or silica, which acts as a lubricant. This has two purposes – it improves the flow of the liquid metal, and it allows the cast part to be withdrawn from the mold more easily. The process can be automated, and therefore yields high throughput rates. Also, it produces very good tolerance and surface finish. It is commonly used for producing pistons used in car engines, gear blanks, cylinder heads, and other parts made of low melting point metals, e.g. copper, bronze, aluminum, magnesium, etc.

In the **pressure casting process** the molten material is forced upward by gas pressure into a graphite mould or metallic mould Fig 8. The pressure is maintained until the melt has completely solidified in the mould. The molten material may also be forced upward by a vacuum, which also removes dissolved gases ahead of the rising melt and produces a casting with lower porosity.

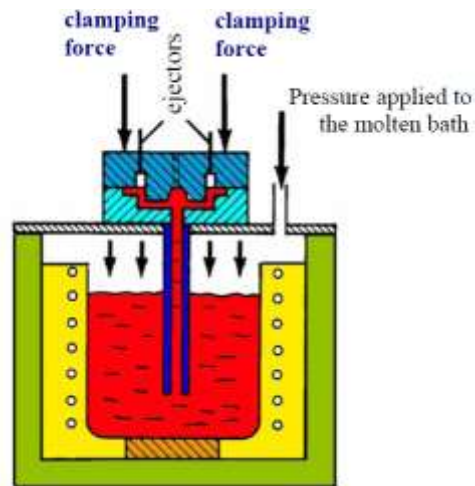


Fig 8: Pressure Casting Process

Variations of this method include Vacuum Riserless Casting (VRC) and Pressure Riserless Casting (PRC). These techniques are capable of producing a range of structural and high performance castings exhibiting excellent mechanical attributes and microstructure refinements in an economical manner. While VRC process uses vacuum to draw the liquid material up into a mould cavity, PRC uses pressure applied to a molten bath to force melt into a mould cavity. Yet another approach combines both techniques to achieve appropriate casting conditions.

Squeeze casting developed in the 1960s, involves solidification of the molten material under high pressure Fig 9. Thus it is a combination of casting and forging. The machinery includes a die, punch, and ejector pin.

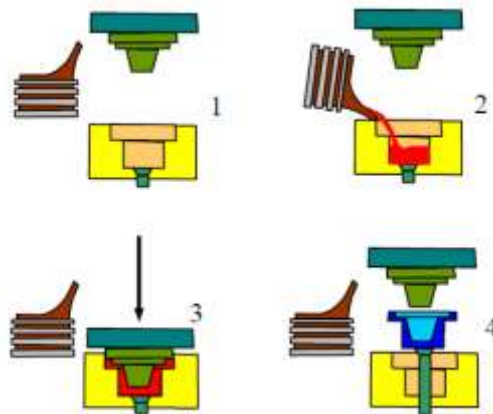


Fig 9: Sequence of operations in squeeze-casting:

1. Bring a ladle filled with liquid material close to the dies
2. Pour liquid in the bottom die cavity
3. Close dies and applies pressure
4. Open dies and ejects the solidified product

The pressure applied by the punch keeps the entrapped gases in solution, and the high-pressure contact at the die-product interface promotes rapid heat transfer, resulting in a fine microstructure with good mechanical properties. Parts can be made to near-net shape, with complex shapes and fine surface detail, from both nonferrous and ferrous alloys. Typical products: automotive wheels and mortar bodies (a short-barreled cannon). The pressures required in squeeze casting are lower than those for hot or cold forging.

Die casting

Die casting is a very commonly used type of permanent mold casting process. It is used for producing many components of home appliances (e.g rice cookers, stoves, fans, washing and drying machines, fridges), motors, toys and hand-tools – since Pearl river delta is a largest manufacturer of such products in the world, this technology is used by many HK-based companies. Surface finish and tolerance of die cast parts is so good that there is almost no post-processing required. Die casting molds are expensive, and require significant lead time to fabricate; they are commonly called dies. There are two common types of die casting: hot- and cold-chamber die casting.

- In a hot chamber process (used for Zinc alloys, magnesium) the pressure chamber connected to the die cavity is filled permanently in the molten metal. The basic cycle of operation is as follows: (i) die is closed and gooseneck cylinder is filled with molten metal; (ii) plunger pushes molten metal through gooseneck passage and nozzle and into the die cavity; metal is held under pressure until it solidifies; (iii) die opens and cores, if any, are retracted; casting stays in ejector die; plunger returns, pulling molten metal back through nozzle and gooseneck; (iv) ejector pins push casting out of ejector die. As plunger uncovers inlet hole, molten metal refills gooseneck cylinder. The hot chamber process is

used for metals that (a) have low melting points and (b) do not alloy with the die material, steel; common examples are tin, zinc, and lead (Fig 10a).

- In a cold chamber process, the molten metal is poured into the cold chamber in each cycle. The operating cycle is (i) Die is closed and molten metal is ladled into the cold chamber cylinder; (ii) plunger pushes molten metal into die cavity; the metal is held under high pressure until it solidifies; (iii) die opens and plunger follows to push the solidified slug from the cylinder, if there are cores, they are retracted away; (iv) ejector pins push casting off ejector die and plunger returns to original position. This process is particularly useful for high melting point metals such as Aluminum, and Copper (and its alloys) (Fig 10b).

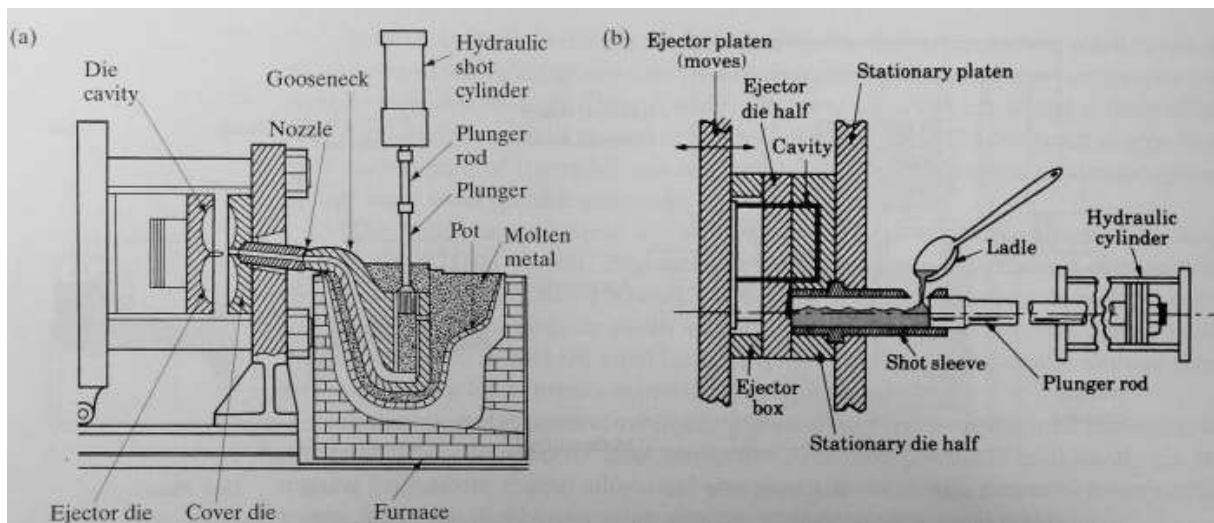


Fig. 10: (a) Hot chamber die casting (b) Cold chamber die casting

The **Die-casting** process is a typical example of permanent-mould casting. The molten material is forced into the die cavity at pressures ranging from 0.7 to 700 MPa. Typical products are carburetors, motor housings, business machine and appliance components, hand tools and toys. The weight of most castings ranges from less than 90 g to about 25 kg.

The **Hot-chamber process** involves the use of a piston, which traps a certain volume of melt and forces it into the die cavity through a gooseneck and nozzle Fig 10c.

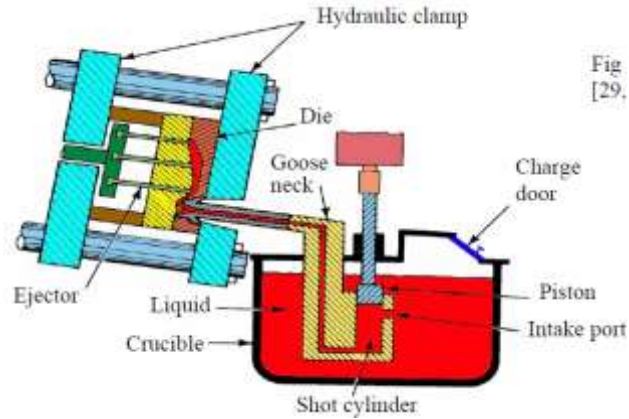


Fig [29,

Fig 10c: Hot-chamber process

The pressures range up to 35 MPa. The melt is held under pressure until it solidifies. To improve die life and to aid in rapid heat transfer, thus reducing the cycle time, dies are cooled by circulating water or oil through passageways in the die block. Cycle times usually range up to 900 shots per hour for zinc, (very small components such as zipper teeth can be cast at 18,000 shots per hour). This process commonly casts low-melting-point alloys of metals such as zinc, tin, and lead.

In the **Cold-chamber process**, molten metal is poured into the injection cylinder with a ladle Fig 10d. The shot chamber is not heated. The melt is forced into the die cavity at pressures ranging from 20 MPa to 70 MPa, (in extremes 150 MPa). The machines may be horizontal or vertical.

Process capabilities and machine selection: High-melting-point alloys of Al, Mg, and Cu are cast by this method; ferrous alloys can also be cast in this manner. The dies have a tendency to part unless clamped together tightly. Die casting machines are rated according to the clamping force and range from 25 t to 3000 t. A further factor in the selection of die-casting machines is the piston stroke which delimits the volume of fluid injected into die cavity.

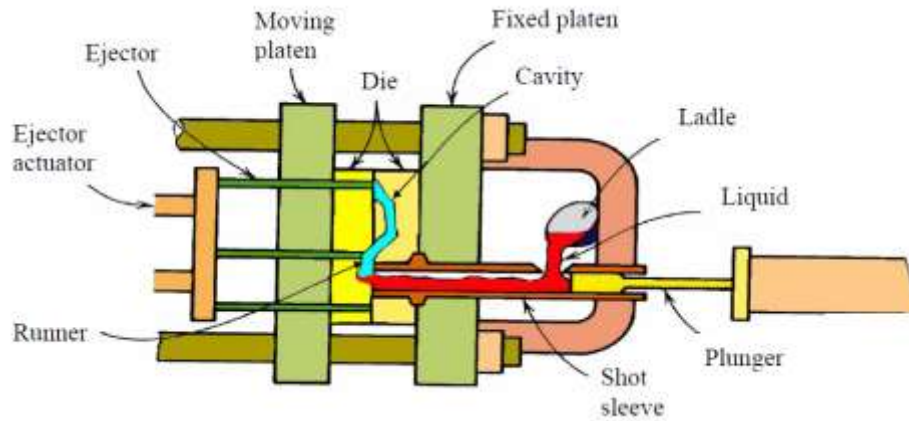


Fig 10d: Cold-chamber process

Dies may be made for single or multiple cavities. Die wear increases with the temperature of the fluid. **Heat cracking** of the die surface from repeated heating and cooling can be a problem. However dies may last more than half a million shots before die wear becomes significant.

The entire die-casting and finishing process can be highly automated. Lubricants are applied, as parting agents on die surfaces. Alloys (except Mg alloys) generally require lubricants. Die-casting has the capability for high production rates with good strength, high-quality parts with complex shapes, good dimensional accuracy and surface detail, thus requiring little or no subsequent machining or finishing operations. Components such as pins, shafts, and fasteners can be cast integrally. Ejector marks remain, as do small amounts of **flash** (thin material squeezed out between the dies) at the die parting line.

Die-casting can compete favourably in some products with other manufacturing methods, such as metallic-sheet stamping or forging. Because the molten material chills rapidly at the die walls, the casting has a fine-grain, hard skin with higher strength than in the centre. The strength-to-weight ratio of die-cast parts increases with decreasing wall thickness. With good surface finish and dimensional accuracy, die-casting can produce bearing surfaces that would normally be machined. The cost of dies is somewhat high, but die-casting is economical for large production runs.

1.10 Centrifugal casting

Centrifugal casting uses a permanent mold that is rotated about its axis at a speed between 300 to 3000 rpm as the molten metal is poured. Centrifugal forces cause the metal to be pushed out towards the mold walls, where it solidifies after cooling. Parts cast in this method have a fine grain microstructure, which is resistant to atmospheric corrosion; hence this method has been used to manufacture pipes. Since metal is heavier than impurities, most of the impurities and inclusions are closer to the inner diameter and can be machined away. The surface finish along the inner diameter is also much worse than along the outer surface.

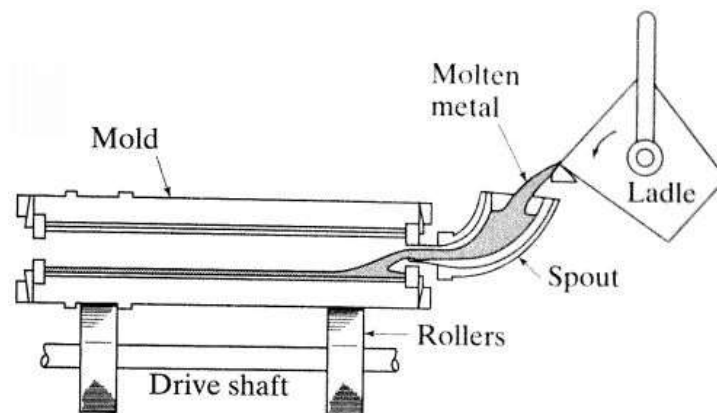


Fig 11: Centrifugal casting schematic

The essential feature of centrifugal casting is the introduction of molten metal into a mold which is rotated during solidification of the casting. The centrifugal force is relied upon for shaping and feeding the molten metal with the utmost of detail as the liquid metal is thrown by the force of gravity into the designed crevices and detail of the mold. (Fig. 11)

The concept of centrifugal casting is by no means a modern process. This technique which lends clarity to detail was used by Benvenuto Cellini and others in the founding arts during the 16th century. The mention of actual centrifugal casting machines is first recorded when a British inventor, A.G. Eckhardt, was issued a patent in the year 1807. His method utilized the placing of the molds in an upright position on pivots or revolving bases (sometimes referred to today as a "vertical" centrifugal casting machine). In 1857 a U.S. patent

described wheel molds which presumably were used for the centrifugal casting of railroad car wheels.

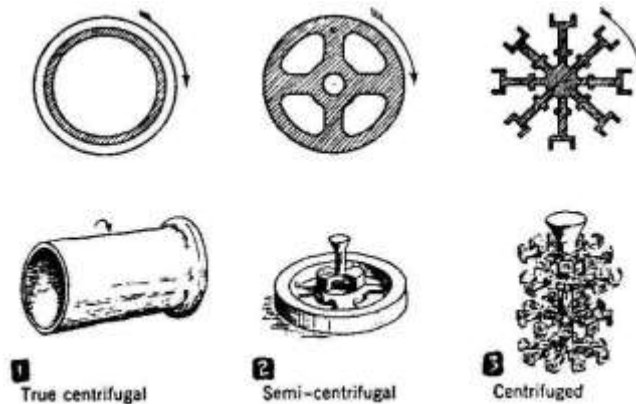
The centrifugal casting of railroad car wheels was one of the first applications involving controlled variations in chemical composition from the outside periphery of the car wheel as compared to the balance of the casting. As the casting was poured, a quantity of ferromanganese was introduced with the first metal to enter the mold. This formed a high manganese wear resistant tread and car wheel flange, as compared to the softer second portion of the molten metal which became the center portion and the hub of the wheel. Although this practice is no longer used, similar applications do exist since, in principle, true solutions will not be separated in the centrifugal casting process.

Centrifugal casting utilizes inertial forces caused by rotation to distribute the molten material into mould cavities. Variations of this manufacturing method include:

True centrifugal casting,

Semi-centrifugal casting, and

Centrifuging (also called **centrifuged** or **spin casting**).



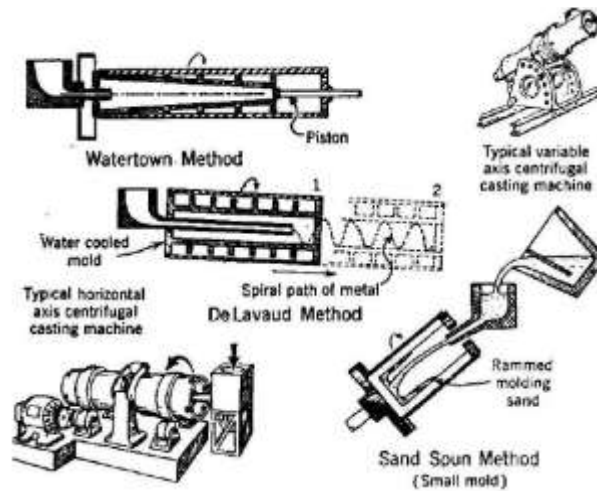


Fig 11a: Centrifugal Casting Methods

It is important to remember, however, that materials such as iron or copper that are immiscible in certain ranges are apt to segregate badly, such as lead in certain bronzes. Tubing with alloy modifications on the inside diameter which are designed to meet specific corrosion resistant characteristics have been successfully produced using the centrifugal casting technique.

Centrifugal casting remained a casting method for large objects until 1907 when Dr. Taggart, a dentist, introduced it to other dentists who experimented with the method hoping to perfect cast inlays for teeth that would replace malleable flake gold into prepared cavities. A Dr. Campbell in Missouri used a Hoosier cowbell as a casting flask. A wire loop such as an extra-long bucket bail was added to the bell, the clapper was removed, and the model and its sprues were embedded in the investment plaster.

After the mold had been heated, the prepared molten metal was poured into the sprue and the bell swung first in pendulum style, then in a circular motion, to force the metal into all areas of the pattern chamber. This action resembled the old trick of swinging a bucketful of water over one's head in a circular motion. After 1920, the process began to be used for the manufacturing of cast iron water pressure pipe, and use of the process has been extended to a much wider range of shapes and alloys.

In centrifugal casting, the mold may spin about a horizontal, inclined or vertical axis. The outside shape of the casting is determined by the shape of the mold. The inside contour is

determined by the free surface of the liquid metal during solidification. The centrifugal force produced by rotation is large compared with normal hydrostatic forces and is utilized in two ways.

The first of these is seen in pouring, where the force can be used to distribute liquid metal over the outer surfaces of a mold. This provides a means of forming hollow cylinders and other annular shapes. The second is the development of high pressure in the casting during freezing. This, in conjunction with directional solidification, assists feeding and accelerates the separation of non-metallic inclusions and precipitated gases. The advantages of the process are therefore twofold: suitability for casting cylindrical forms and high metallurgical quality of the product,

The effectiveness of centrifugal force in promoting a high standard of soundness and metallurgical quality depends above all on achieving a controlled pattern of solidification, this being governed by the process used and by the shape and dimensions of the casting. High feeding pressure is no substitute for directional freezing, which remains a primary aim of casting technique.

Considering first the casting of a plain cylinder, conditions can be seen to be highly favorable to directional solidification owing to the marked radial temperature gradient extending from the mold wall. Under these conditions the central mass of liquid metal, under high pressure, has ready access to the zone of crystallization and fulfills the function of the feeder head used in static casting. The steepest gradients and the best conditions of all occur in the outermost zone of the casting, especially when a metal mold is employed.

Another important factor is the length to diameter ratio of the casting, a high ratio minimizing heat losses from the bore through radiation and convection. Under these conditions, heat is dissipated almost entirely through the mold wall and freezing is virtually unidirectional until the casting is completely solid; the wall of the casting is then sound throughout.

The casting of a plain pipe or tube is accomplished by rotation of a mold about its own axis—the bore shape being produced by centrifugal force alone, and the wall thickness determined by the volume of metal introduced. This practice is widely referred to as "true centrifugal casting." (Fig. 11b)

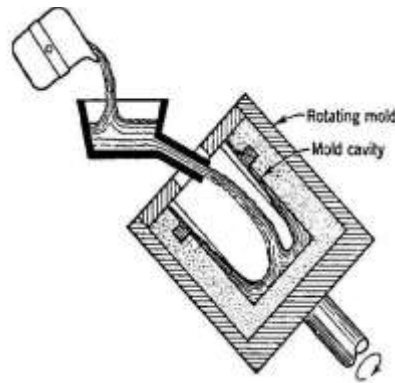


Fig 11b: True Centrifugal Casting

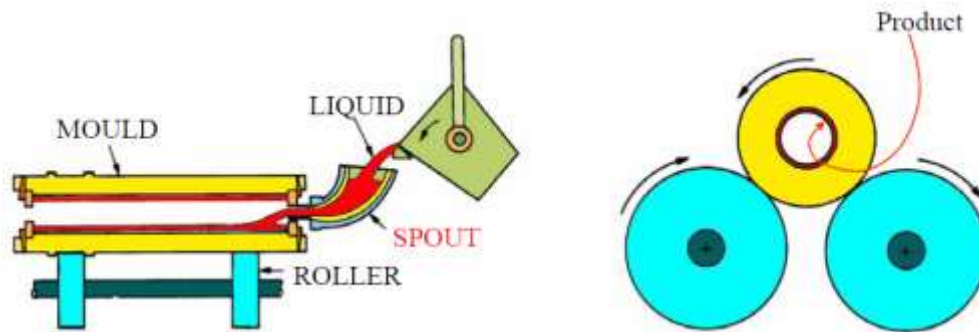


Fig 11c: True Centrifugal Casting

In **true centrifugal casting**, Fig 11c, hollow cylindrical parts, e.g. pipes and lampposts, are produced by pouring liquid into a rotating mould. The axis of rotation is usually horizontal but can also be vertical. Moulds are made of steel, cast iron, or graphite and may be coated with a refractory lining to increase mould life. Pipes with various outer shapes, (including polygonal) can be cast. The inner surface of the casting remains cylindrical because the molten material is uniformly distributed by centrifugal forces. Because of density differences, lighter particles such as dross and impurities tend to collect on the inner surface of the casting.

Cylindrical parts ranging from $\varnothing 13$ mm to 3 m in diameter and 16 m long can be produced with wall thickness ranging from 6 mm to 125 mm. The acceleration generated by the centrifugal force is high, as much as 150 g, and is necessary for casting thick-walled parts. This process enables good dimensional accuracy, and external surface detail. Typical products are pipes, bushings, engine cylinder liners, and bearing rings with or without

flanges. Apart from metallic products some glass and ceramic products_(e.g. TV picture tubes and ceramic membrane tubes) are also manufactured using this technique.

In the case of a component of varying internal diameter or irregular wall thickness, a central core may be used to form the internal contours, feeder heads then being introduced to compensate for solidification shrinkage. A further step away from the original concept is the spacing of separate shaped castings about a central downsprue which forms the axis of rotation. These variations are referred to respectively as "semi-centrifugal casting and centrifuging or pressure casting." In both cases, since the castings are shaped entirely by the mold and cores, centrifugal force is used primarily as a source of pressure for feeding.

Semi-Centrifugal Casting

Such items as wheels and pulleys are occasionally cast in a semi-centrifugal setup as illustrated in (Fig. 11d). This type of mold need not be rotated as fast as in the case of a true centrifugal casting for only enough force is needed to cause the metal to first flow to the outer rim. As the wheel rotates around its hub core, the mold cavity is filled from rim to hub not from bottom to top as is the case of common gravity pouring. This action promotes the direction of solidification from rim to hub and provides the required feeding by using only one central reservoir. Pouring and feeding on the center hub increases the yield especially when casting high shrinkage alloys. Here, as in other centrifugal setups, the centrifugal force helps force lightweight nonmetallic inclusions and trapped gas toward the center and into the feeder for elimination.

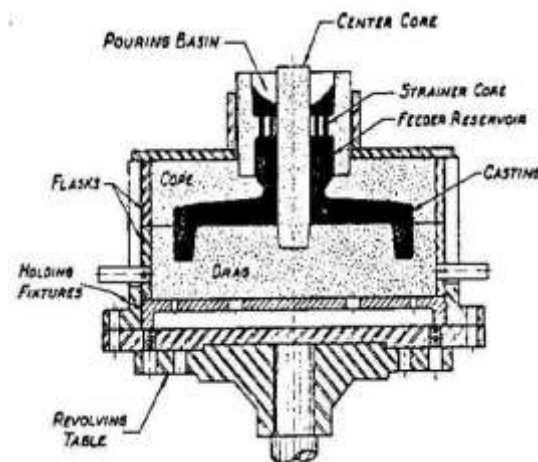


Fig. 11d Semi-Centrifugal Casting

In true or open bore casting, circumferential velocity is imparted from mold to metal by frictional forces at the mold surface and within the liquid. In horizontal axis casting, the metal entering the mold must rapidly acquire sufficient velocity to prevent instability and "raining" as it passes over the upper half of its circular path, because of slip, the generation of the necessary minimum force of 1G in the metal requires a much greater peripheral mold velocity than would be the case if metal and mold were moving together. (Fig. 11e)

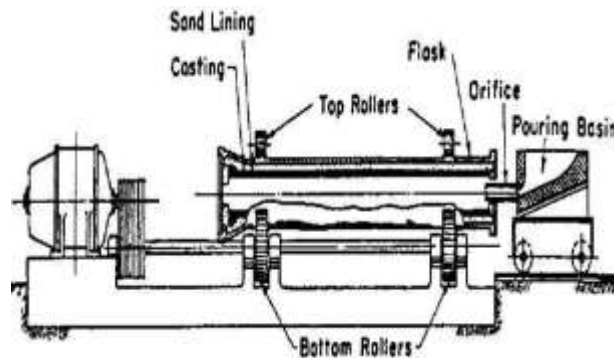


Fig 11e: Schematic representation of True Centrifugal Casting Machine

Semi-centrifugal casting is used to cast parts with rotational symmetry, such as wheels with spokes and central hub. This technique can be applied to most expendable and permanent moulds.

In **Centrifuging** mould cavities of odd shape are placed at a certain distance from the axis of rotation. The molten material is forced into the mould by centrifugal forces. The attributes within the castings vary with the distance from the axis of rotation, Fig 11f.

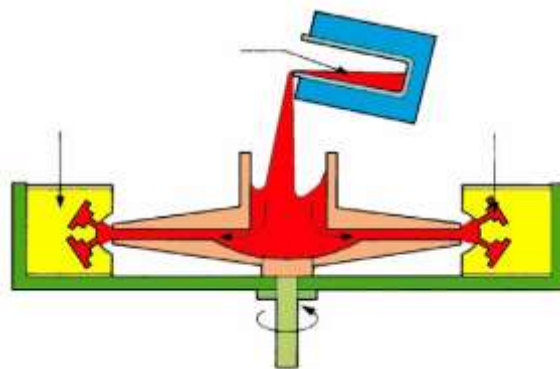


Fig 11f: Centrifuging

Vertical Centrifugal Casting

Vertical castings are produced by pouring a given weight of metal into a mold that rotates about a vertical axis. The metal is picked up and distributed on the inside surface of the mold. Dross, slag and other nonmetallics are centrifuged to the inside. Unlike the horizontal casting, it is not possible to obtain a uniform bore. Depending on the rotational speed of the mold, the inside will have varying amounts of taper. The inside surface will be that of the parabola of revolution. The paraboloid "A" in Fig. 11g shows the shape of the cavity formed by a relatively high rotational speed and paraboloid "B" shows the approximate shape of the cavity that would be formed at a lower speed. This fact can be utilized advantageously in the production of certain conically shaped parts.

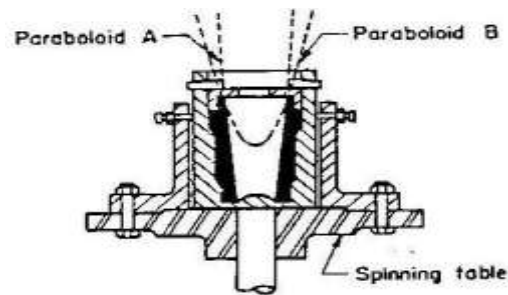


Fig 11g: Vertical Centrifugal Casting

The vertical axis centrifugal casting method is not suited to the production of pipelike shapes because of the inherent taper on the inside. Likewise, it is not suited to the production of very long parts. It finds its greatest application in the production of ringlike shapes. Because the inside contour can be controlled to some extent, the method is particularly useful in producing tapered sections. Also, because the rotational speeds can be lower than in the horizontal axis machine, there is greater latitude in modifying the outside shape.

Vertical casting machines consist of a rotating table on which a mold is centered and fastened. The machine must be constructed to withstand static and dynamic loads imposed on it. The dynamic loading is the most critical. Speed controls are infinitely variable and speed regulation should be good. For safety's sake the machines are often mounted below

floor level. They are provided with adequate shields for protection in case of runout or machine failure.

1.11 Rheocasting processes

Semi-solid metal casting is a near net shape variant of die casting. The process is used with non-ferrous metals, such as aluminium, copper, and magnesium. The process combines the advantages of casting and forging. The process is named after the fluid property thixotropy, which is the phenomenon that allows this process to work. Simply, thixotropic fluids shear when the material flows, but thicken when standing. The process of thixocasting offers a number of advantages, such as improved mechanical properties, good surface finish, near net shape and so on. However, the thixocasting process has also a number of disadvantages, such as the need for special feedstock with near spherical primary crystals. In order to cast such special billets for thixocasting one has to pay a more expensive premium than normal. Eliminating this additional specialized casting step leads to savings in both costs and time. A product can be cast into a near net shape part directly from the molten metal state as in rheocasting, where the need of special billet is removed. Therefore, rheocasting is advantageous from an energy and cost saving point of view when compared to thixocasting. In the early days of semisolid casting research, mechanical stirring was used in order to achieve the right microstructures. More recently, electric stirring has used. There are two kinds of rheocasting process using a cooling slope and a process using low superheat casting, respectively. In the process using the cooling slope, the metal is in the semisolid condition when it flows into the die. In the low superheat casting process, the seed of the crystals are generated at the die surface. The casting is carried out before the crystal seeds could be re-melted. The crystal seeds could then grow to become spherical primary crystals. In the processes described only pouring of the molten metal into the die has been needed for the semisolid casting to take place. In conventional semisolid casting, the solid metal fraction content is usually 50%, however, in this process; casting has been tried at lower than 50% fraction solids. The primary crystal size becomes smaller as the solid rate becomes lower. In thixocasting, metal handling is difficult at fraction solids lower than 50%. However, in rheocasting, casting metal with lower

fraction solids is easy because the product, which is thin, can be cast at low fraction solids. Fig. 10 shows the two rheocasting processes devised in this discussion.

The molten metal was poured into the lower die half via the cooling slope. The molten metal became semisolid slurry on the cooling slope. The cooling slope, which is very compact and simple, is made from mild steel, it is water-cooled and as a package offers both low equipment costs and low running costs. The cooling slope can be easily mounted as part of any conventional casting machine. In conventional semisolid casting process, a typical fraction solid of about 50% is required, however, the present study aimed at fraction solids lower than 50%. The primary crystal size in the product becomes smaller as the fraction solid is reduced. The solidification rate of the semisolid slurry after flowing through on the cooling slope was about 10%. Casting was done immediately after pouring without holding the slurry in order not to increase the solidification rate. Therefore, there was no need of a system that controls the rate of solidification; this simplified the processes investigated in the present study. Fig. 10(b) shows the rheocasting process that used low superheat casting. The superheat of the molten metal was 10 °C. The crystal seeds are generated at the lower die surface, and the upper die is inserted into the lower die before the metal solidifies. When the superheat of the molten metal is low, the crystal seeds do not melt and if sufficient crystal seeds remain, they can grow into spheroidal primary crystals. The low superheat casting is simpler than the cooling slope process.

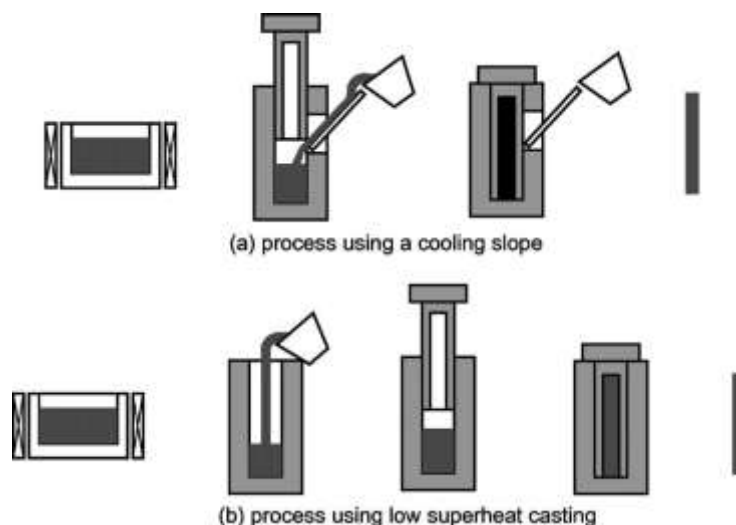


Fig. 12 Two kinds of Rheocasting process

1.12 Continuous Casting

Continuous casting transforms molten metal into solid on a continuous basis and includes a variety of important commercial processes. These processes are the most efficient way to solidify large volumes of metal into simple shapes for subsequent processing. Most basic metals are mass-produced using a continuous casting process, including over 500 million tons of steel, 20 million tons of aluminum, and 1 million tons of copper, nickel, and other metals in the world each year. Continuous casting is distinguished from other solidification processes by its steady state nature, relative to an outside observer in a laboratory frame of reference. The molten metal solidifies against the mold walls while it is simultaneously withdrawn from the bottom of the mold at a rate which maintains the solid / liquid interface at a constant position with time. The process works best when all of its aspects operate in this steady-state manner. Relative to other casting processes, continuous casting generally has a higher capital cost, but lower operating cost. It is the most cost- and energy- efficient method to mass-produce semifinished metal products with consistent quality in a variety of sizes and shapes. Cross-sections can be rectangular, for subsequent rolling into plate or sheet, square or circular for long products, and even “dog-bone” shapes, for rolling into I or H beams.

In the continuous casting, molten steel is poured from the tundish in the water cooled mold and partially solidified bloom/billet or slab (hereafter called strand) is withdrawn from the bottom of the mold into water spray so that solidified bloom/billet or slab is produced constantly and continuously. Continuous casting is widely adopted by steelmakers. The advantages of continuous casting over ingot casting are

- Quality of the cast product is better
- No need to have slabbing / blooming or billet mill as required when ingot casting is used.
- Higher extent of automation is possible
- Width of the slab can be adjusted with the downstream strip mill.
- Continuously cast products show less segregation.
- Hot direct charging of the cast product for rolling is possible which leads to energy saving.

The essential components of a continuous casting machine are tundish, water cooled mold, water spray and torch cutters. Tundish, mold and water spray are arranged such that molten stream is poured from tundish to mold and solidified strand (billet/bloom/billet) is produced continuously. The required length of the strand is cut by torch cutter. In Fig. 13, the arrangement of tundish, mold and water spray is shown. Various continuous casting processes are shown in Fig 13a.

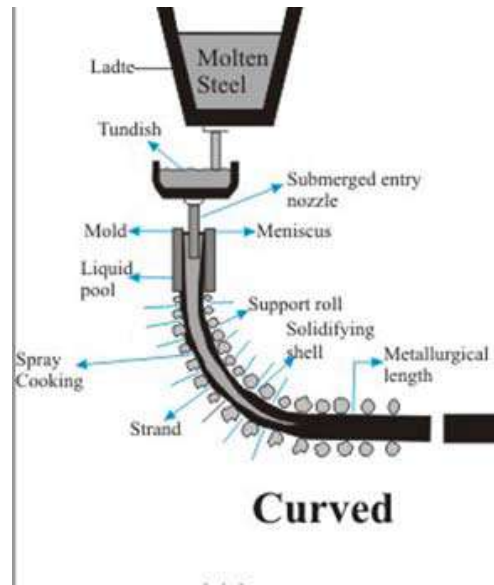


Fig 13: Arrangement of tundish, mold and water spray in a curved mold machine

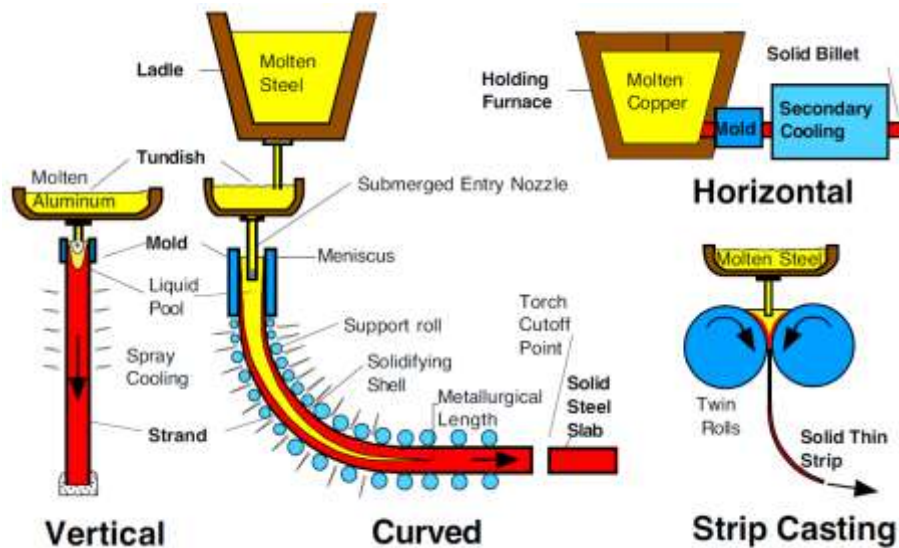


Fig. 13a Various continuous casting processes

Tundish

Tundish is a refractory lined vessel. Liquid steel is usually tapped from ladle into tundish. The stream is shrouded as it enters from ladle to tundish. The functions of the tundish are:

Reservoir of molten steel

Tundish acts as a reservoir for molten steel. It supplies molten steel in presence of a slag cover to all continuous casting molds constantly and continuously at constant steel flow rate. The flow rate is maintained constant by maintaining a constant steel bath height in the tundish through teeming of molten steel from the ladle. The number of mold is either one or more than one. Normally bloom and billet casting machines are multi strand i.e. number of molds are either 4 or 6 or 8. Slab casters usually have either single or two molds. During sequence casting and ladle change over periods, tundish supplies molten steel to the molds.

Distributor

Tundish distributes molten steel to different molds of the continuous casting machine at constant flow rate and superheat which is required for stand similarly with reference to solidification microstructure. Control of superheat is required in all the moulds to reduce break out. Location of ladles stream in the tundish is important. It may be located symmetric or asymmetric to the centre of the tundish depending on the number of mold. For single strand machines, molten stream enters from one side and exits the other side of the tundish. In multi strand tundishes, ladle stream is either at the centre of the tundish or displaced to the width side of the tundish.

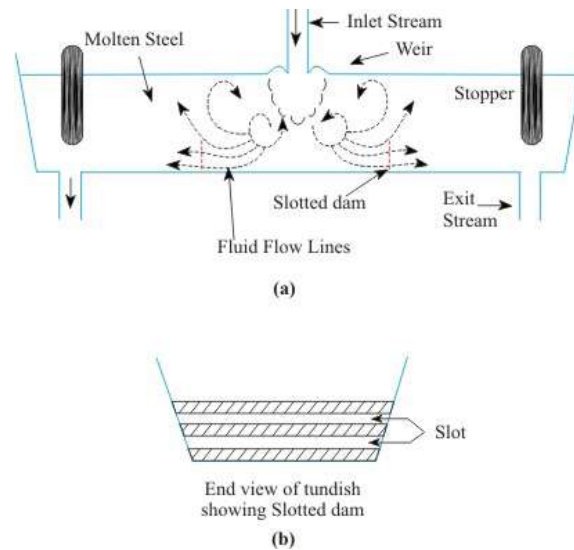


Fig. 13b: Tundish with flow control device, namely weir and slotted dam

Inclusion removal

Tundish helps to remove inclusions during the process of continuous casting. For this purpose liquid steel flow in the tundish is modified by inserting dams, weirs, slotted dams etc. The whole idea is to utilize the residence time available before steel leaves the tundish. For example, if capacity of tundish is 40 tons and casting speed is 5 tons/min, then the average residence time of molten steel in the tundish is 8 minutes. During this average residence time, inclusion removal can be exercised. For this purpose flow of steel melt in the tundish has to be modified so as to accelerate the inclusion removal. The Inclusion removal is a two-step unit operation, namely floatation and absorption by a flux added on the surface of the tundish. Flux is usually rice husk, or fly ash or some synthetic powder.

Mold:

Mold is the heart of continuous casting. In the water cooled mold, molten stream enters from the tundish into mold in presence of flux through the submerged nozzle immersed in the liquid steel. Solidification of steel begins in the mold. The casting powder is added onto the top of molten steel in the mold. It melts and penetrates between the surface of mold and the solidifying strand to minimize friction as shown in Fig 13c. Control of height of molten steel in the mould is crucial for the success of the continuous casting machine. The

solidification begins from the meniscus of steel level in the mould. Mold level sensors are used to control the meniscus level in the mould.

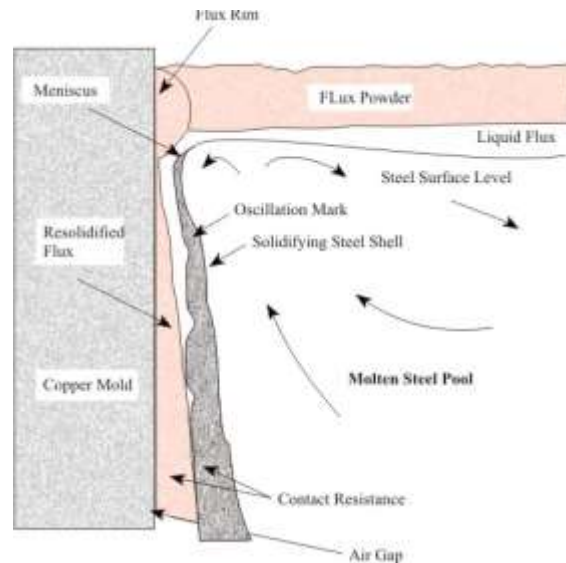


Fig13c: Role of flux in continuous casting mold

As seen in the figure, flux melts and enters into the gap between mold surface and solidified strand. Molds are made of copper alloys. Small amounts of alloying elements are added to increase the strength. Mold is tapered to reduce the air gap formation. Taper is typically 1% of the mold length. For cross section of mold the taper is about 1mm for 1m long mold. The cross section of the mold is the cross section of the slab/bloom/billet. Length of the mold is around 0.7 and is more for large cross sections. Mold cross section decreases gradually from top to bottom. Mould extracts around 10% of the total heat.

The mold is oscillated up and down to withdraw the partially solidified strand (strand is either billet or bloom or slab). The oscillated frequency can be varied. At Tata steel slab caster frequency is varied in between 0 and 250 cycles/min and the stroke length from 0 to 12mm.

Steel level in mould is controlled, that is the meniscus for smooth caster operation. Sensors are used to control the meniscus level.

The functions of mold flux are.

- Inclusion absorption capability
- Prevention of oxidation
- Minimization of heat losses
- Flux on melting enters into the air gap and provides lubrication

For the above functions the flux should have the following properties.

- Low viscosity
- Low liquidus temperature
- Melting rate of flux must match with the speed of the continuous casting.

2. The Capabilities of major casting processes are compared in Table 2.

Table 2: Capabilities of major casting processes

Attribute \ Process	Sand	Investment	Gravity Die	Pressure Die
Maximum size	several tons	up to 20 kg	up to 50 kg	up to 8 kg
Dimensional tolerance	> 0.6 mm	> 0.1 mm	> 0.4 mm	> 0.05 mm
Surface finish	> 200 RMS	> 60 RMS	> 150 RMS	> 30 RMS
Minimum thickness	> 6 mm	> 1.5 mm	> 4.5 mm	> 0.8 mm
Economic quantity	any number	> 100	> 500	> 2500
Sample lead time	2-10 weeks	8-10 weeks	8-20 weeks	12-24 weeks

The hierarchical classification of various casting processes are summarized in Fig. 14.

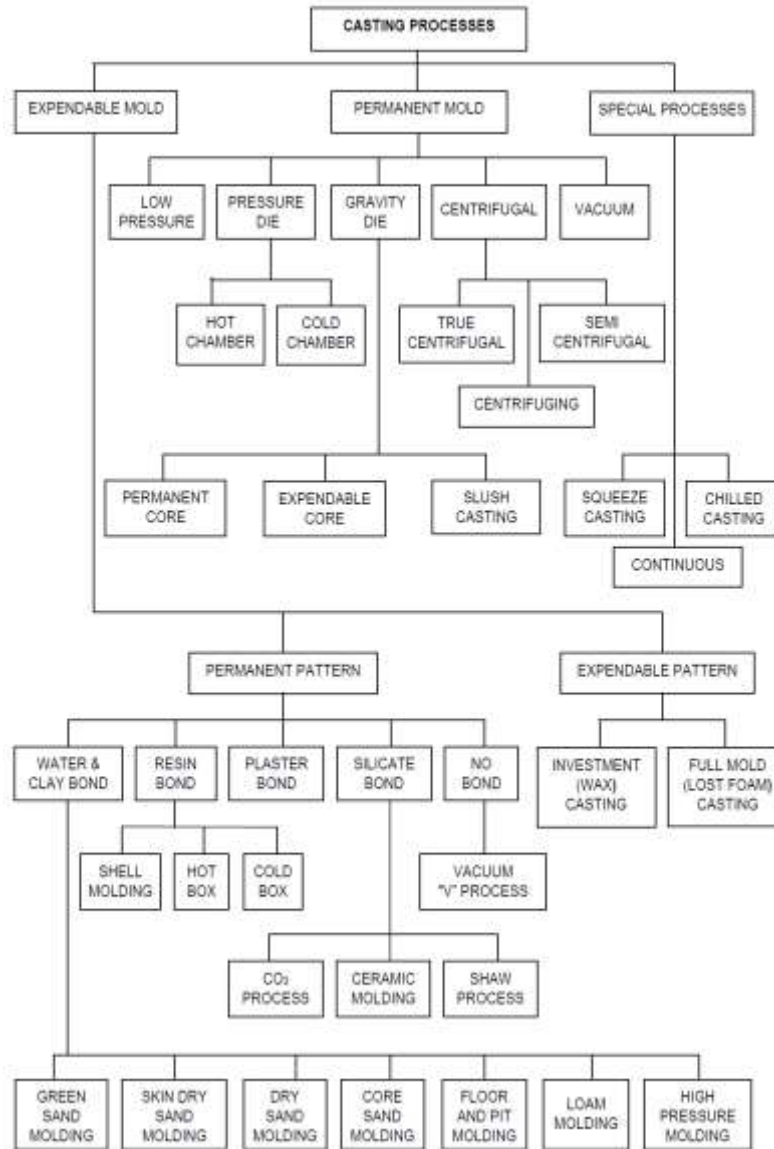


Fig.14 Hierarchical classification of various casting processes

2.1 Sand mould and core making

Sand casting is the most common production technique, especially for ferrous castings. Sand is mixed with clay and water or with chemical binders and then packed or rammed around the pattern to form a mould half. The two halves are joined together to make the mould - a rigid cavity that provides the required shape for the casting, as shown in Fig. 15 below. Variations on this technique include the use of plaster in place of sand and the recently invented Pattern less process, where the mould is machined directly out of a sand block without the need for a pattern.

Cores are produced by blowing, ramming or in heated processes, investing sand into a core box. The finished cores, which can be solid or hollow, are inserted into the mould to provide the internal cavities of the casting before the mould halves are joined. Sand cores are also widely used in die-casting, where permanent metal moulds are employed.

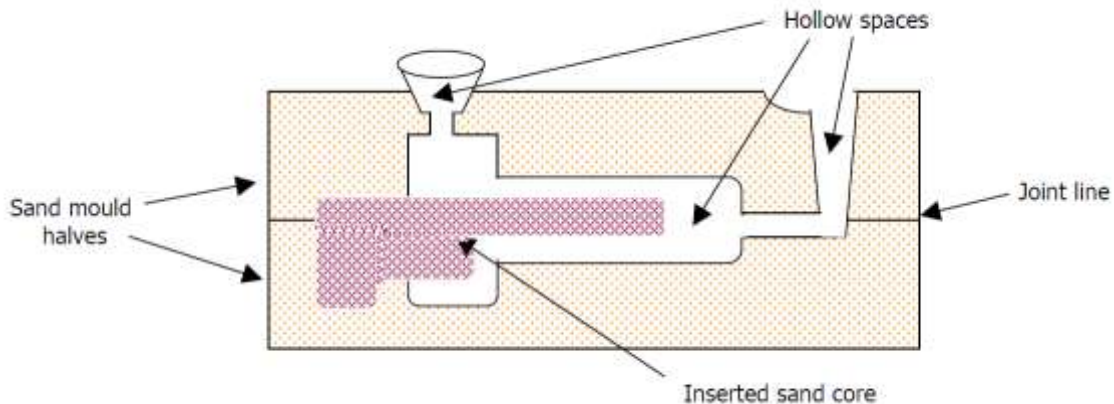


Fig 15: Assembled Mould with Core Inserted Ready for Casting

Sand Preparation: Moulding sand should have good flowability (for better reproduction of pattern details), adequate green strength (to prevent its collapse during moulding), dry strength (to prevent its collapse during mould filling), sufficient refractoriness (to withstand molten metal temperature), enough permeability (to allow entrapped air and gases generated inside the mould to escape) and collapsibility (for ease of shakeout).

These are achieved by a suitable composition of sand, binders, additives and moisture. Silica sand is the most widely available and economical. Special sands include zirconsand (lower thermal expansion, higher refractoriness and higher thermal conductivity, but more expensive), olivine sand (with properties in between silica and zircon sand) and chromite/magnesite sand (high thermal conductivity). The most widely used binder is bentonite clay (sodium or calcium bentonite), which imparts strength and plasticity to silica sand with the addition of water. Additives include coal dust (to improve surface finish by gas evolution at metal-mould interface), iron oxide (for high temperature resistance), dextrin (for improved toughness and collapsibility) and molasses (for high strength and collapsibility). Modern sand plants automatically carry out mulling, mixing, aeration and testing of the sand. They also reclaim used sand through magnetic separation (to remove metal

particles), crushing of lumps and finally removal of excess fines and bond (usually by washing in hot water or by mechanical impact).

Core Making: Cores are surrounded by molten metal, and have higher requirements compared to mould sand in terms of strength (to support their own weight and the buoyancy force of metal), permeability and collapsibility (especially for curved holes, otherwise they will be difficult to clean out). The most widely used binder for core sands is vegetable oil (linseed and corn oil, sometimes mixed with mineral oils), which is economical, but requires heating in an oven to about 240 °C for 2-3 hours to develop sufficient strength. Another widely used process uses sodium silicate binder mixed in dry sand free of clay; the sand mixture hardens immediately when CO₂ gas is passed through it. The process is highly productive. The core develops high compressive strength but has poor collapsibility. Other processes are based on organic binders; mainly thermosetting resins such as phenol, urea and furan. This includes *hot box* and *cold box* processes. The core sand mixed with binder is filled into a core box either manually or using a sand slinger. For higher productivity core blowing machines are used, in which core boxes are mounted in the machine and sand is forced and pressed into the core box under a stream of high velocity air. This is followed by appropriate heating of the core box to impart the desired properties to the core.

Moulding: This involves packing the moulding sand uniformly around a pattern placed in a moulding box (or flask). Most foundries are equipped with jolt-squeeze machines operated by compressed air. The combination of jolting and squeezing action gives good compaction of sand near the pattern (by jolting the sand into crevices) as well as the top where the squeeze plate comes in contact with the mould. Many modern foundries have high pressure moulding equipment, which use air impulse or gas injection to impact the sand on the pattern. These machines produce relatively less noise and dust compared to jolt and squeeze machines and have much higher productivity (several moulds per minute). A special type of high pressure moulding machine is the flaskless moulding machine pioneered by Disomatic, in which the parting plane is vertical and the mould cavity is formed between consecutive blocks of mould.

2.2 Heating the Metal

- Heating furnaces are used to heat the metal to molten temperature sufficient for casting
- The heat required is the sum of:
 1. Heat to raise temperature to melting point
 2. Heat of fusion to convert from solid to liquid
 3. Heat to raise molten metal to desired temperature for pouring

Pouring the Molten Metal

- For this step to be successful, metal must flow into all regions of the mold, most importantly the main cavity, before solidifying
- Factors that determine success: Pouring temperature, pouring rate, Turbulence

2.3 Solidification of Metals

Transformation of molten metal back into solid state • Solidification differs depending on whether the metal is a pure element or an alloy

A pure metal solidifies at a constant temperature equal to its freezing point (same as melting point)

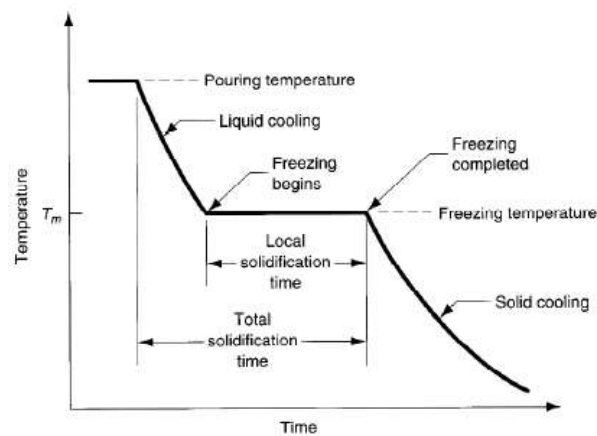


Fig 16 - Cooling curve for a pure metal during casting

Solidification of Pure Metals

- Due to chilling action of mold wall, a thin skin of solid metal is formed at the interface immediately after pouring

- Skin thickness increases to form a shell around the molten metal as solidification progresses
- Rate of freezing depends on heat transfer into mold, as well as thermal properties of the metal

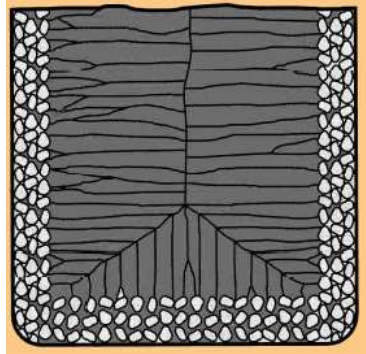


Figure 16a - Characteristic grain structure in a casting of a pure metal, showing randomly oriented grains of small size near the mold wall, and large columnar grains oriented toward the center of the casting

Most alloys freeze over a temperature range rather than at a single temperature

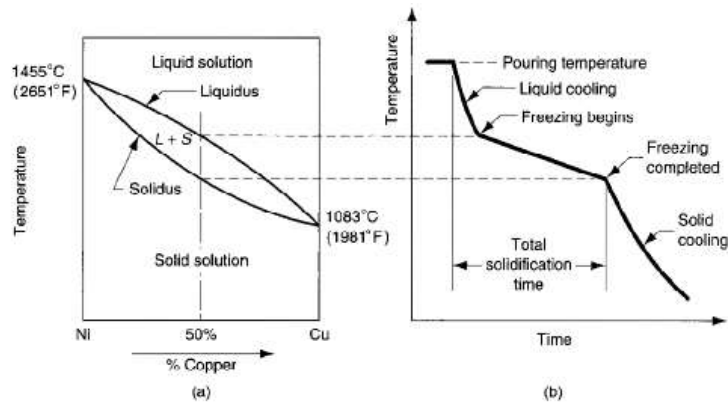


Figure 17 - (a) Phase diagram for a copper-nickel alloy system and (b) associated cooling curve for a 50%Ni-50%Cu composition during casting



Figure 18 - Characteristic grain structure in an alloy casting, showing segregation of alloying components in center of casting

Solidification Time

- Solidification takes time
- Total solidification time TST = time required for casting to solidify after pouring
- TST depends on size and shape of casting by relationship known as *Chvorinov's Rule*

$$TST = C_m \left(\frac{V}{A} \right)^n$$

where TST = total solidification time; V = volume of the casting; A = surface area of casting; n = exponent usually taken to have a value = 2; and C_m is *mold constant*

Mold Constant in Chvorinov's Rule

- C_m depends on mold material, thermal properties of casting metal, and pouring temperature relative to melting point
- Value of C_m for a given casting operation can be based on experimental data from previous operations carried out using same mold material, metal, and pouring temperature, even though the shape of the part may be quite different

A casting with a higher volume-to-surface area ratio cools and solidifies more slowly than one with a lower ratio

- To feed molten metal to main cavity, TST for riser must greater than TST for main casting

- Since riser and casting mold constants will be equal, design the riser to have a larger volume-to-area ratio so that the main casting solidifies first
- This minimizes the effects of shrinkage

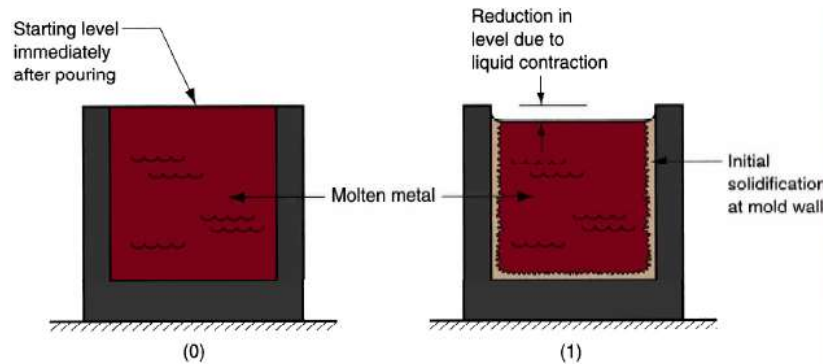


Figure 19 - Shrinkage of a cylindrical casting during solidification and cooling: (0) starting level of molten metal immediately after pouring; (1) reduction in level caused by liquid contraction during cooling (dimensional reductions are exaggerated for clarity in sketches)

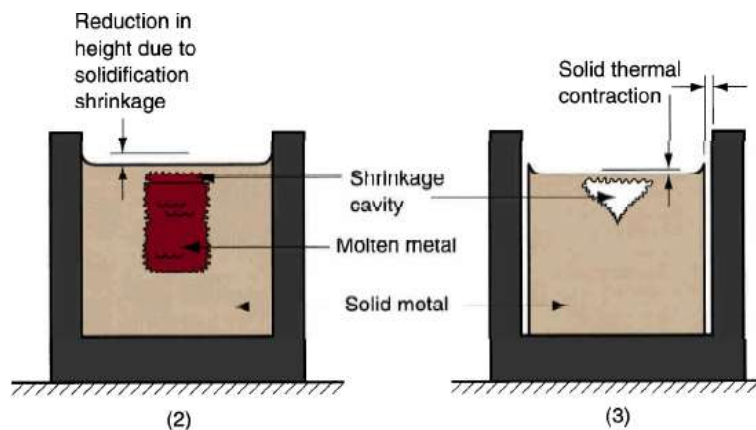


Figure 20 - (2) reduction in height and formation of shrinkage cavity caused by solidification shrinkage; (3) further reduction in height and diameter due to thermal contraction during cooling of the solid metal (dimensional reductions are exaggerated for clarity in our sketches)

Solidification Shrinkage

- Occurs in nearly all metals because the solid phase has a higher density than the liquid phase
- Thus, solidification causes a reduction in volume per unit weight of metal

- Exception: cast iron with high C content

--Graphitization during final stages of freezing causes expansion that counteracts volumetric decrease associated with phase change

Shrinkage Allowance

- Patternmakers account for solidification shrinkage and thermal contraction by making mold cavity oversized

- Amount by which mold is made larger relative to final casting size is called *pattern shrinkage allowance*

- Casting dimensions are expressed linearly, so allowances are applied accordingly

Directional Solidification

- To minimize damaging effects of shrinkage, it is desirable for regions of the casting most distant from the liquid metal supply to freeze first and for solidification to progress from these remote regions toward the riser(s)

Thus, molten metal is continually available from risers to prevent shrinkage voids

The term *directional solidification* describes this aspect of freezing and methods by which it is controlled

Achieving Directional Solidification

- Desired directional solidification is achieved using Chvorinov's Rule to design the casting itself, its orientation in the mold, and the riser system that feeds it

- Locate sections of the casting with lower V/A ratios away from riser, so freezing occurs first in these regions, and the liquid metal supply for the rest of the casting remains open

- Chills* - internal or external heat sinks that cause rapid freezing in certain regions of the casting

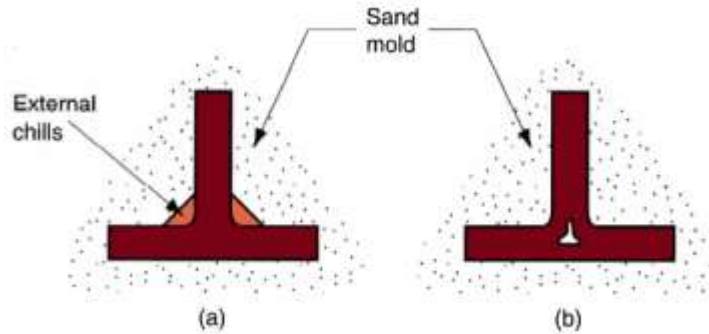


Figure 21 - (a) External chill to encourage rapid freezing of the molten metal in a thin section of the casting; and (b) the likely result if the external chill were not used

Riser Design

- Riser is waste metal that is separated from then casting and remelted to make more castings
- To minimize waste in the unit operation, it is desirable for the volume of metal in the riser to be a minimum
- Since the geometry of the riser is normally selected to maximize the V/A ratio, this allows reduction of riser volume as much as possible

Melting: Most widely used melting equipment include cupola, oil/gas fired furnaces (including crucible and rotary furnaces), direct arc furnace and induction furnace. The cupola is the simplest and the most economical, and most suited for grey iron. Layers of pig iron, coke and flux (limestone) are charged into the cupola; air for combustion is blown through several openings (tuyeres). Use of hot air blast and double row tuyeres improves cupola efficiency. Oil or gas fired crucible furnaces are suitable for melting small quantities of metal, usually non-ferrous. The crucible is usually made of graphite and clay. Rotary furnaces are made of steel shells lined with refractory, turning at a rate of 1-2 rpm. The charge is placed through a door in the middle; one end of the furnace is heated (by firing oil or gas) and the melt is taken out through the other end. Electric furnaces include direct arc and induction furnaces, which are more widely preferred by newer foundries owing to ease of control over temperature and composition, and high melting rate. In arc furnace, the heat is generated between the electrodes and transferred to the metal. In induction furnace, the heat is generated in the metal itself by eddy currents. Induction furnaces can be classified

depending on the location of the induction coil (cored and coreless), and frequency of current (high or medium).

Molten metal is prepared in a variety of furnaces, the choice of which is determined by the quality, quantity and throughput required.

Electric induction furnaces are the most common type used for batch melting of ferrous, copper and super alloys. This method involves the use of an electrical current surrounding a crucible that holds the metal charge. Furnace sizes range from < 100 kg up to 15 tons. For production of super alloys and titanium, melting may be undertaken in a vacuum chamber to prevent oxidation.

Cupolas are used solely by iron foundries for continuous production of molten iron. The cupola consists of a shaft in which a coke bed is established. Metal, coke and limestone are alternately charged into the furnace from the top. Molten metal trickles through the coke bed picking up essential carbon, while impurities react with the limestone to form waste slag. Both metal and slag are continuously tapped out at the bottom. Metal throughputs of 1 to 45 tons per hour are achieved in the UK.

Electric arc furnaces are still used by a few ferrous foundries in the UK, mainly producing steel castings, although most have been replaced by induction furnaces. Furnaces of 3 to 100 tons capacity are in use in the UK. The design involves the use of a holding bath into which electrodes are inserted. The heat generated by creating a charge between the electrodes causes the metal to melt.

Rotary furnaces are relatively uncommon in the UK but are used in some iron foundries. The furnace consists of a horizontal cylindrical steel shell mounted on rollers and lined with refractory material. The furnace is fired using gas or oil from one end and the furnace body is slowly rotated during melting.

Gas-fired shaft and resistance furnaces are used for melting of aluminium. Shaft furnaces provide a continuous melting and tapping capability, useful at high production facilities. Resistance furnaces are employed for melting of small batches.

Gas and oil-fired crucible furnaces are used for small batch melting of copper and aluminium alloys, although oil-fired units are less common now and tend to be limited to

smaller foundries. Unlike the larger furnaces where molten metal is tapped into a ladle for casting, the crucible is lifted out (or pops out) of the heating chamber and the molten metal can be poured directly into the mould.

2.4 Casting Applications

Castings can range in size: from a few grams (for example, watch case) to several tones (marine diesel engines), shape complexity: from simple (manhole cover) to intricate (6-cylinder engine block) and order size: one-off (paper mill crusher) to mass production (automobile pistons). The desired dimensional accuracy and surface finish can be achieved by the choice of process and its control. Castings enable many pieces to be combined into a single part, eliminating assembly and inventory and reducing costs by 50% or more compared to machined parts. Unlike plastics, castings can be completely recycled. Today, castings are used in virtually all walks of life. Major areas of applications are given below (see Fig. 1.3). The transport sector and heavy equipment (for construction, farming and mining) take up over 50% of castings produced.

Transport: automobile, aerospace, railways and shipping

Heavy equipment: construction, farming and mining

Machine tools: machining, casting, plastics moulding, forging, extrusion and forming

Plant machinery: chemical, petroleum, paper, sugar, textile, steel and thermal plants

Defense: vehicles, artillery, munitions, storage and supporting equipment

Electrical machines: motors, generators, pumps and compressors

Municipal castings: pipes, joints, valves and fittings

Household: appliances, kitchen and gardening equipment, furniture and fittings

Art objects: sculptures, idols, furniture, lamp stands and decorative items

Virtually any metal or alloy that can be melted can be cast. The most common ferrous metals include grey iron, ductile iron, malleable iron and steel. Alloys of iron and steel are used for high performance applications, such as temperature, wear and corrosion resistance. The most common non-ferrous metals include aluminum, copper, zinc and magnesium based alloys. The production and application of ductile iron and

aluminum castings are steadily increasing. Aluminum has overtaken steel in terms of production by weight. The consumption of magnesium alloys is rapidly increasing in automobile and other sectors, owing its high strength to weight ratio. Important and emerging metal titanium is stronger than steel, but has found limited applications owing to the difficulty in casting and machining. Table 3 lists the major metals in use today (by weight) along with their main characteristics and typical applications.

Table 3: Major cast metals

METAL	USE	CHARACTERISTICS	APPLICATIONS
Grey Iron	54%	Heat resistance, damping, low cost, high fluidity, low shrinkage.	Automobile cylinder block, clutch plate, brake drum, machine tool beds, housings
Ductile Iron	20%	Strength, wear and shock resistance, dimensional stability, machinability.	Crank shafts, cam shafts, differential housing, valves, brackets, rollers.
Aluminum	12%	Strength to weight ratio, corrosion resistance.	Automobile pistons, oil and fuel pumps, connecting rod, clutch housings.
Steel	9%	Strength, machinability, weldability	Machine parts, gears, valves
Copper base	2%	High ductility, corrosion resistance.	Marine impellers, valves, hydraulic pump parts.
Zinc base	1%		

Module-II

Casting defects, inspection, diagnosis and rectification, mechanization and automation in foundries, use of robots, casting design, near net shape casting, pollution control, energy and waste management in foundries.

Physics of welding arc, characteristics of arc, modes of metal transfer, welding fluxes, electrode coating, classification of electrode, characteristics of welding power source, pulsed and inverter type power source, power source for resistance welding, weldability, weldability tests, Weldability of cast iron, Plain carbon steel, Determination of preheating temperature, Stainless steel, use of Scheffler' s diagram.

3. Introduction to Casting Defects:

Some defects are common to any and all process. These defects are illustrated in Fig 22 and briefly described in the following:

There are numerous opportunities in the casting operation for different defects to appear in the cast product. Some of them are common to all casting processes:

Misruns: Casting solidifies before completely fill the mold. Reasons are low pouring temperature, slow pouring or thin cross section of casting.

Cold shut: Two portions flow together but without fusion between them. Causes are similar to those of a misrun.

Cold shots: When splattering occurs during pouring, solid globules of metal are entrapped in the casting. Proper gating system designs could avoid this defect.

Shrinkage cavity: Voids resulting from shrinkage. The problem can often be solved by proper riser design but may require some changes in the part design as well.

Microporosity: Network of small voids distributed throughout the casting. The defect occurs more often in alloys, because of the manner they solidify.

Hot tearing: Cracks caused by low mold collapsibility. They occur when the material is restrained from contraction during solidification. A proper mold design can solve the problem.

3.1 Some defects are typical only for some particular casting processes, for instance, many defects occur in sand casting as a result of interaction between the sand mold and the molten metal. Defect found primarily in sand casting are gas cavities, rough surface areas, shift of the two halves of the mold, or shift of the core, etc.

a) Misruns: A Misruns is a casting that has solidified before completely filling the mold cavity. Typical causes include

- 1) Fluidity of the molten metal is insufficient,
- 2) Pouring Temperature is too low,
- 3) Pouring is done too slowly and/or
- 4) Cross section of the mold cavity is too thin.

b) Cold Shut: A cold shut occurs when two portion of the metal flow together, but there is lack of fusion between them due to premature freezing, Its causes are similar to those of a Misruns.

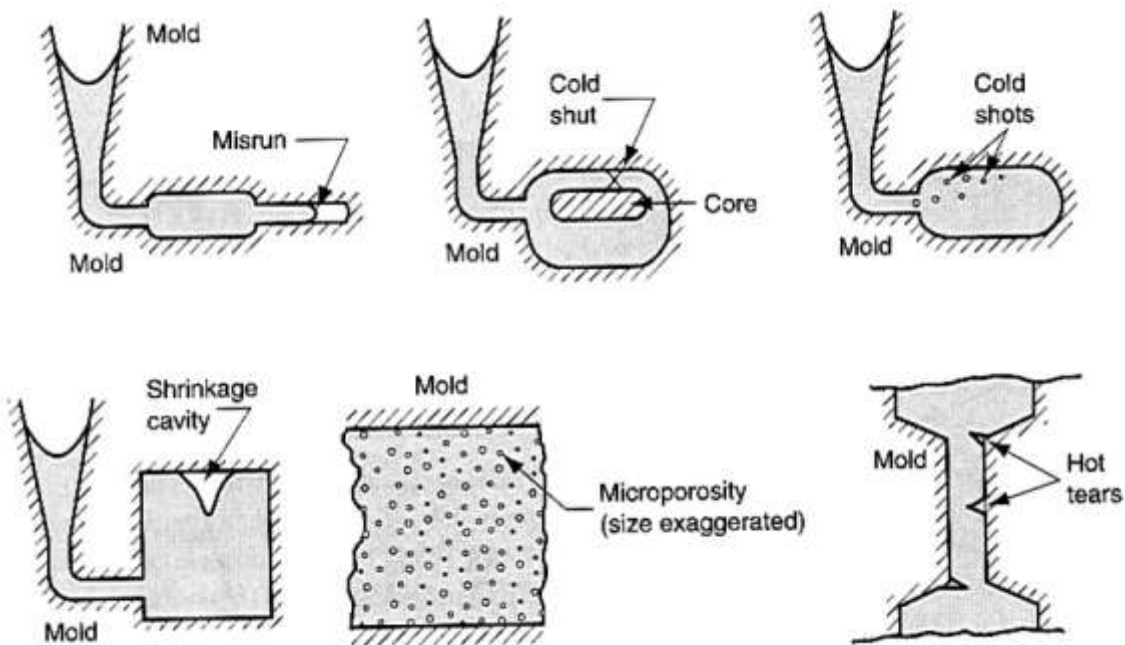


Fig. 22 Some common defects in castings

c) **Cold Shots:** When splattering occurs during pouring, solid globules of the metal are formed that become entrapped in the casting. Poring procedures and gating system designs that avoid splattering can prevent these defects.

d) **Shrinkage Cavity:** These defects are a depression in the surface or an internal void in the casting caused by solidification shrinkage that restricts the amount of the molten metal available in the last region to freeze. It often occurs near the top of the casting in which case it is referred to as a pipe. The problem can often be solved by proper riser design.

e) **Microporosity:** This refers to a network of small voids distributed throughout the casting caused by localized solidification shrinkage of the final molten metal in the dendritic structure. The defect is usually associated with alloys, because of the protracted manner in which freezing occurs in these metals.

f) **Hot Tearing:** This defect, also called hot cracking, occurs when the casting is restrained or early stages of cooling after solidification. The defect is manifested as a separation of the metal (hence the terms tearing or cracking) at a point of high tensile stress caused by metal's inability to shrink naturally. In sand casting and other expandable mold processes, compounding the mold to be collapsible prevents it. In permanent mold processes, removing the part from the mold immediately after freezing reduces hot tearing.

Some defects are related to the use of sand molds and therefore they occur only in sand castings. To a lesser degree, other expandable mold processes are also susceptible to these problems.

Defects found primarily in sand castings are shown in Fig 23 and describe here:

a) **Sand Blow:** This defect consists of a balloon-shaped gas cavity caused by release of mold gases during pouring. It occurs at or below the casting surface near the top of the

casting. Low permeability, poor venting and high moisture content of the sand mold are the usual causes.

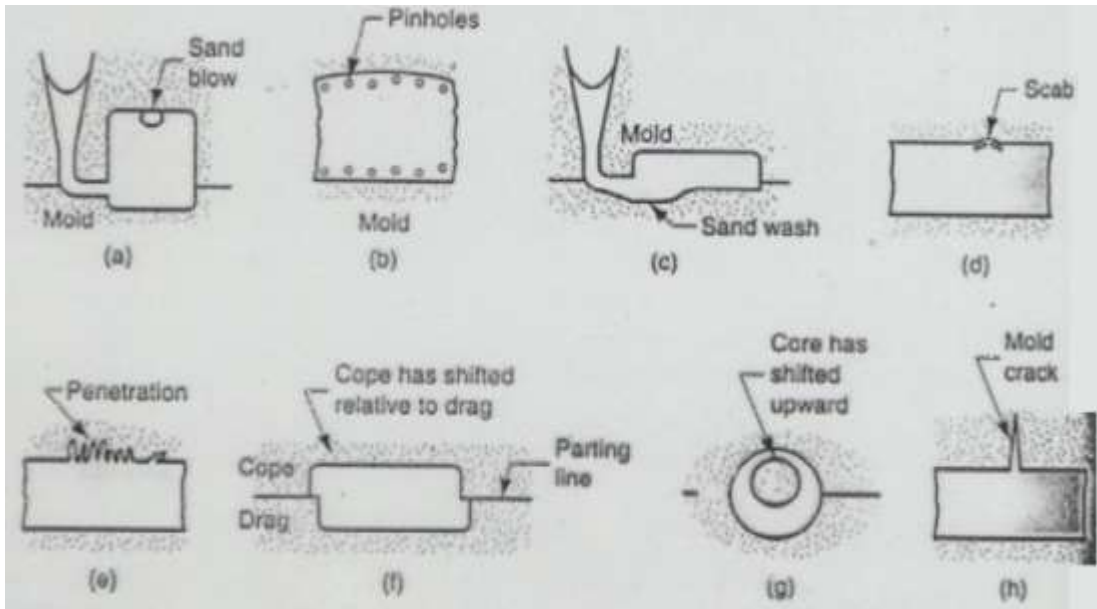


Fig. 23 Other defects found primarily in sand castings

b) **Pinholes**: A defect similar to a sand blow involves the formation of many small gas cavities at or slightly below the surface of the casting.

c) **Sand Wash**: A wash is an irregularity in the surface of the casting that results from erosion of the sand mold during pouring. The contour of the erosion is imprinted into surface of the final cast part.

d) **Scabs**: This is a rough area of the casting due to encrustations of sand and metal. It is caused by portions of the mold surface flaking off during solidification and becoming embedded in the casting surface.

e) **Penetration**: When the fluidity of the liquid metal is high, it may penetrate into the sand mold or sand core after freezing, the surface of the casting consists of a mixture of sand grains and metal. Harder packing of the sand molds helps to alleviate this condition.

f) **Mold Shift:** This is manifested as a step in the cast product at the parting line caused by sidewise displacement of the cope with respect to the drag.

g) **Core Shift:** A similar movement can happen with the core but the displacement is usually vertical. Core shift and mold shift are caused by buoyancy of the molten metal.

h) **Mold Crack:** If mold strength is insufficient a crack may develop in to which liquid metal can seep to form a fin on the final casting.

3.2 Issues in Casting

- Shrinkage
- Porosity
- Piping
- Microstructure

Shrinkage

- Can amount to 5-10% by volume
- Gray cast iron expands upon solidification due to phase changes
- Need to design part and mold to take this amount into consideration

TABLE 5.1

Metal or alloy	Volumetric solidification contraction (%)	Metal or alloy	Volumetric solidification contraction (%)
Aluminum	6.6	70%Cu–30%Zn	4.5
Al–4.5%Cu	6.3	90%Cu–10%Al	4
Al–12%Si	3.8	Gray iron	Expansion to 2.5
Carbon steel	2.5–3	Magnesium	4.2
1% carbon steel	4	White iron	4–5.5
Copper	4.9	Zinc	6.5

Porosity

- Types
 - due to gases – smooth bubbles
 - due to shrinkage – rough voids
- Not a problem for ingots
 - parts that will be deformation processed

- as long as it is not exposed to air (corrosion)
- can be healed

Porosity due to Gases

- Smooth bubbles
- result from entrapped gases
- solubility in liquid is high, in solid is low, so gas is rejected during cooling

Sievert's law

$$S = k p_g^{0.5}$$

- S = solubility
- k = constant
- p_g = partial pressure of gas over melt

Remedies for Gas Bubbles

- Control atmosphere
 - vacuum
 - gases with less solubility
- Proper venting to let gases out
- Proper design of runners and gates to avoid turbulence
- Add metallic elements to react with gases
 - Killed steels - highly deoxidized (Al, Si)
- high shrinkage due to gas removal - piping
 - Semi-killed steels - less deoxidized
- less piping, porosity
 - Rimmed steels - little deoxidization
- blow holes in ring at rim (sometimes break through)
- little piping because gas doesn't escape

Porosity due to Shrinkage

- Rough bubbles - voids

- Stages

- cooling liquid

- rejects latent heat at melting point

- alloys become slushy - liquid and solid co-exist

- cooling solid

Differential Cooling

- Transition between thicker and thinner sections can lead to porosity

Porosity / Shrinkage Solutions

- Risers allow molten metal to flow into mold to make up for shrinkage

- Design flow so no part freezes early

- large channels

- “Flexible” molds

- allow metal to shrink, not hold metal

Heating or cooling certain areas to maintain uniform cooling (thermit or chills)

- Uniform part thickness

- leads to uniform cooling, less residual stress

Pipe Defect

- Due to shrinkage giving rise to a funnel-like cavity

- Solutions

- insulate top (glass wool)

- heat top (exothermic mixture - thermit)

Microstructure

- Post-treatment may be necessary to get desired properties - grain structure

- annealing

- tempering

- cold working

Design Rules Summary

- Uniform wall thickness
- Flat parting lines
- Gradual thickness transitions
- Draft for removal
- tapers: 0.5 to 2 degrees
- Surface of mold gives surface of part

Cost Equation

$$C = C_m + \frac{C_c}{n} + \frac{C_L}{\dot{n}}$$

- C = cost/part
- C_m = material cost
- C_c = capital cost
- C_L = labor cost
- n = number produced
- \dot{n} = production rate

Process	Sand Casting	Low Pressure	Permanent Mold	Die Casting
Material, C _m (\$)	1	1	1	1
Labor, C _L (\$/hr)	20	20	20	20
Capital, C _c (\$)	0.9	4.4	700	3000
Rate, \dot{n} (#/hr)	6.25	22	10	50

Process Selection / Economics

- Probably pick low pressure casting, as a preliminary run of 100 is assured.
- If production run is needed, die casting will probably be used.
- The tough part is getting the process cost data.

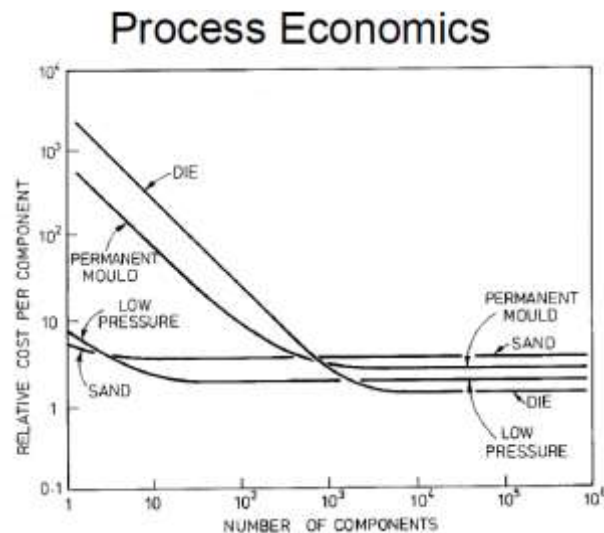


Fig 24

4. Inspections of Casting

Foundry inspection procedures include;

- a. Visual Inspection to detect obvious defects, such as Misruns, cold shut and severe surface flaws;
- b. Dimensional measurements to ensure that tolerances have been met;
- c. Metallurgical, chemical, physical and other tests concerned with the inherent quality of the cast metal. Tests in category 3 include
 - 1) Pressure testing to locate leaks in the casting
 - 2) Radiographic methods, magnetic particle tests, the use of fluorescent penetrants and supersonic testing to detect either surface or internal defects in the casting;
 - 3) Mechanical testing to determine properties such as tensile strength and hardness. If defects are discovered but are not too serious, it is often possible to save the casting by welding, grinding or other salvage methods to which the customer has agreed.

Visual inspection

Visible defects that can be detected provide a means for discovering errors in the pattern equipment or in the molding and casting process. Visual inspection may prove inadequate only in the detection of sub surface or internal defects.

Dimensional inspection

Dimensional inspection is one of the important inspections for casting. When precision casting is required, we make some samples for inspection the tolerance, shape size and also measure the profile of the cast. This dimensional inspection of casting may be conducted by various methods:

- Standard measuring instruments to check the size of the cast.
- Contour gauges for the checking of profile, curves and shapes
- Coordinate measuring and Marking Machine
- Special fixtures

X-Ray Radiography

In all the foundries the flaw detection test are performed in the casting where the defects are not visible. This flaw detection test is usually performed for internal defects, surface defects etc. These tests are valuable not only in detecting but even in locating the casting defects present in the interior of the casting. Radiography is one of the important flaw detection test for casting. The radiation used in radiography testing is a higher energy (shorter wavelength) version of the electromagnetic waves that we see as visible light. The radiation can come from an X-ray generator or a radioactive source.

Magnetic particle inspection

This test is used to reveal the location of cracks that extend to the surface of iron or steel castings, which are magnetic nature. The casting is first magnetized and then iron particles are sprinkled all over the path of the magnetic field. The particles align themselves in the direction of the lines of force. A discontinuity in the casting causes the lines of the force to bypass the discontinuity and to concentrate around the extremities of the defect.

Fluorescent dye-penetration test

This method is very simple and applied for all cast metals. It entails applying a thin penetration oil-base dye to the surface of the casting and allowing it to stand for some time so that the oil passes into the cracks by means of capillary action. The oil is then thoroughly wiped and cleaned from the surface. To detect the defects, the casting is painted with a coat of whitewash or powdered with tale and then viewed under ultraviolet light. The oil being fluorescent in nature, can be easily detect under this light, and thus the defects are easily revealed.

Ultrasonic Testing

Ultrasonic testing used for detecting internal voids in casting is based on the principle of reflection of high frequency sound waves. If the surface under test contains some defect, the high frequency sound waves when emitted through the section of the casting, will be reflected from the surface of defect and return in a shorter period of time.

The advantage this method of testing over other methods is that the defect, even if in the interior, is not only detected and located accurately, but its dimension can also be quickly measured without in any damaging or destroying the casting.

Fracture test

Fracture test is done by examining a fracture surface of the casting. it is possible to observe coarse graphite or chilled portion and also shrinkage cavity, pin hole etc. The apparent soundness of the casting can thus be judged by seeing the fracture.

Macro-etching test (macroscopic examination)

The macroscopic inspection is widely used as a routine control test in steel production because it affords a convenient and effective means of determining internal defects in the metal. Macro-etching may reveal one of the following conditions:

- Crystalline heterogeneity, depending on solidification
- Chemical heterogeneity, depending on the impurities present or localized segregation and
- Mechanical heterogeneity, depending on strain introduced on the metal, if any.

Sulphur Print test

Sulphur may exist in iron or steel in one of two forms; either as iron sulphide or manganese sulphide. The distribution of sulphur inclusions can easily examined by this test.

Microscopic Examination

Microscopic examination can enable the study of the microstructure of the metal alloy, elucidating its composition, the type and nature of any treatment given to it, and its mechanical properties. In the case of cast metals, particularly steels, cast iron, malleable iron, and SG iron, microstructure examination is essential for assessing metallurgical structure and composition. Composition analysis can also be done using microscopic inspection. Distribution of phase can be observed by metallographic

sample preparation of cast product. Grain size and distribution, grain boundary area can be observed by this procedure. Distribution of nonmetallic inclusion can also be found from this process of inspection.

Chill Test

Chill test offers a convenient means for an approximate evaluation of the graphitizing tendency of the iron produced and forms an important and quick shop floor test for ascertaining whether this iron will be of the class desired. In chill test, accelerated cooling rate is introduced to induce the formation of a chilled specimen of appropriate dimension. It is then broken by striking with a hammer in such a manner that the fracture is straight and midway of its length. The depth of chill obtained on the test piece is affected by the carbon and silicon present and it can therefore be related to the carbon equivalent, whose value in turn determines the grade of iron.

5. Application of Robots in Foundry

Like many other industries, foundries are constantly on the lookout for new ways to boost their productivity, cut costs and increase quality. But once the decision for ABB's leading high-performance robot technology has been made, there is no need to look any further: lower production costs and scrap rates, increased up-time and consistent, superior quality are the compelling benefits with ABB robots.

Following the automotive trend with the massive shift from iron to aluminium and other light alloys – for both ecological and economic reasons – foundries are investing heavily in new machinery. With the aluminium content in vehicles rising by 5.5 % each year, some 12 million tonnes of aluminium will be cast in 2010. To handle this workload, around 70 new foundries will have to be built annually. At ABB we are moving right along with this trend, providing the new businesses with proven robot-based solutions including progressive production cell technology.

Experienced solutions for downstream aluminium our commitment to foundry automation is based on almost 40 years of experience and covers every aspect of the

production process – all the way from smelter to the finished automotive part. ABB's robots are always there to gain efficiency along the entire value chain. This synergised-system concept based on specific robots designed for the need of each process offers many advantages like enormous flexibility, high levels of reliability, and consistent capacity utilisation all along the foundry line.

Even for a robot, a foundry is not a workplace like any other. The exceptionally tough work environment demands appropriate protection – the more comprehensive the better. ABB offers an extensive range of foundry-adapted robots with payloads up to 650 kg, by specialized high function controllers and a wide range of software products.

IRC5: the modularised way to success ABB's innovative IRC5 robot control system sets new standards with its modularised concept, a human-engineered Flex Pendant programming unit with special foundry applications interface and fully synchronous, simultaneous control of up to four robots using Multi Move. The patented True Move and Quick Move functions assure precise, rapid robot movements throughout the working range.

Robot Studio: for genuine offline programming Cost-efficient offline programming is the best way to maximise return on investment in robotics. ABB's simulation and offline programming software, Robot Studio, allows robot programming to be carried out in the office without shutting down production. It also enables robot programs to be prepared in advance, increasing overall productivity.

Teach Saver: more than a time-saver for a long time, the elaborate programming required was the biggest impediment to using robots to clean cast components. ABB's Teach Saver software package reduces this process by up to 90%. More: using a virtual offline robot cell also ensures significantly greater accuracy than with classical teaching.

Completely sealed, equipped with a two-component high-resistance enamel surface and IP67 certified, ABB's Foundry Plus range of fully foundry adapted industrial robots

can take more than just the heat. These robots are ready to meet the challenges of spits, sands and lubricants of modern high-performance foundries on a daily basis.

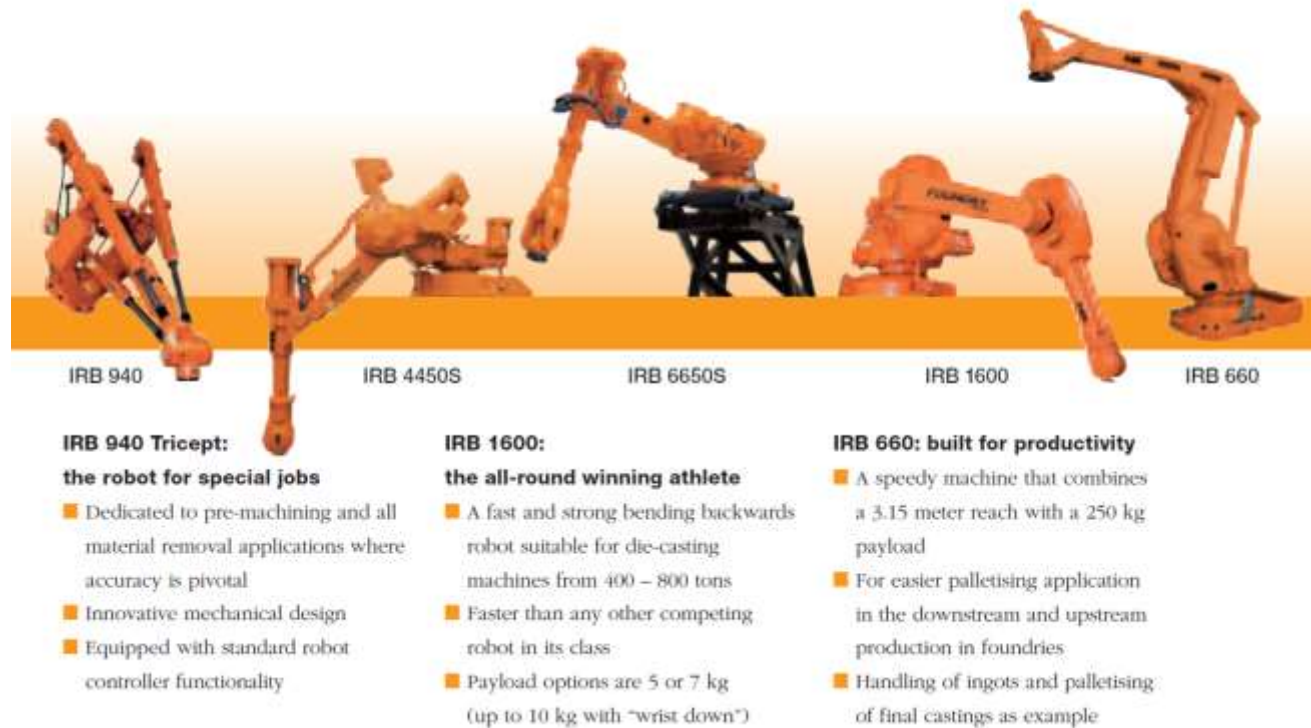


Fig 25 Typical Robots used in Foundry

Foundries are a very complex environment to work in. The automation of specialised tasks such as investment casting, ingot handling or forging requires detailed process know-how and the right hardware to handle castings and cores with power and precision. This is where ABB’s robots enter the arena.

Dipping wax trees in water based slurry to continuously build the ceramic shell with special sand, is a process in investment casting that is often robotised. With a reach of up to 3.5 m and a handling capacity of 150 kg, ABB’s IRB 7600 is the perfect alternative to get the job done. Furthermore, robots are frequently used for post processing applications such as grinding and polishing.

Ingot handling is an application found in casting shops where aluminium ingots are produced. When it comes to handling, the IRB 660 four-axis robot is the perfect tool for the task: it comes equipped with a special purpose pneumatic gripper for handling the solidified aluminium ingots and features a payload of up to 250 kg. For even heavier handling, the IRB 7600 is the perfect choice with a capacity of up to 650 kg.

Tending a zinc die-casting machine requires total reliability and efficiency in a harsh environment. The IRB 140 Foundry Plus robot featuring full IP67- classification is ready to take this challenge. Thanks to its compact dimensions, it is even suited for portable robot cells that can be moved away for tool changes and servicing of the die-casting machine.

6. Metal Casting Design

The principles of successful casting design involve a systematic blend of experience and engineering basics to allow the creation of a successful casting, from inception through production. The major components of the design process are outlined in the six steps listed below and described graphically and schematically in the figure shown.

Casting Design Steps

Physical Design of Part to be Cast

Purpose of Casting (Size, Shape), Tolerances (manufacturing and engineering), Dimensional change in processes, Relationship of this Part to Others to optimize its Design (Concurrent Engineering)

Material Selection for Part to be Cast

Mechanical and physical properties, castability, section size sensitivity, fluid flow Properties

Pattern Production For Molds and Cores

Gating and Riser Design, Fluid flow and Heat Transfer

Casting Process Selection, Casting Production

Limitations due to metal cast, casting size, dimensional requirements

Cost to Produce

After Casting Processing

Machining, heat treating, welding

Evaluation of Cast Product

The casting design process is an iterative procedure, requiring excellent communication in all steps of the process. This communication is illustrated through the use of arrows in the schematic below. Clearly the designer of the casting (often a mechanical engineer) needs to understand the fundamental material properties of the casting, its limitations as a material, and the limitations on the potential processes needed to produce that casting. General considerations by designers include: *Minimize Section Size Changes; Eliminate Sharp Corners; Understand the Mechanical Property Requirements of the Casting, the Machining Requirements, Tolerancing, the Locating Requirements, the Handling Requirements, the Process Limitations, and How Statistical Methods Can Be Used in Process Control.*

Experienced pattern makers with the help of fluid flow and heat transfer experts (often metallurgical engineers) will proceed to lay out the requirements for the molds and the cores necessary to produce the part. At this point in the process, or even in the design stage, simulation of the solidification of the proposed part is a desirable activity. Modern computers are currently being used with powerful software packages to give a preview of solidification, illustrating in color and in real time the path of solidification in the casting. This methodology is important in reducing the time between design and prototype castings, in providing valuable insight to the designer and the person who does the gating and risering.

General considerations applied to the prototype castings by the casting engineer include: Evaluate Dimensional Accuracy; Quantify Microstructural Integrity (presence of required microconstituents, casting defects, porosity, shrinkage, other); Understand Response to Machining, Heat Treatment or Welding; Determine Mechanical Properties in Critical Sections. Rapid prototyping of castings is currently being used to reduce the time between design and cast parts. Stereolithography, Selective Laser Sintering,

Fused Deposition Modeling, Laminated Object Manufacturing, Solid Ground Curing, and Direct Shell Production Casting are some of the methods used to produce patterns very quickly from the CAD models of the designer.

6.1 Pattern Design

Pattern making is a time-honored skill which is an integral part of the casting process.

Patterns are routinely produced from wood, plastics, and metals depending upon the complexity of the casting being produced, on the number of castings required and obviously on the capability of the pattern shop that is involved. The design of patterns must include the following components:

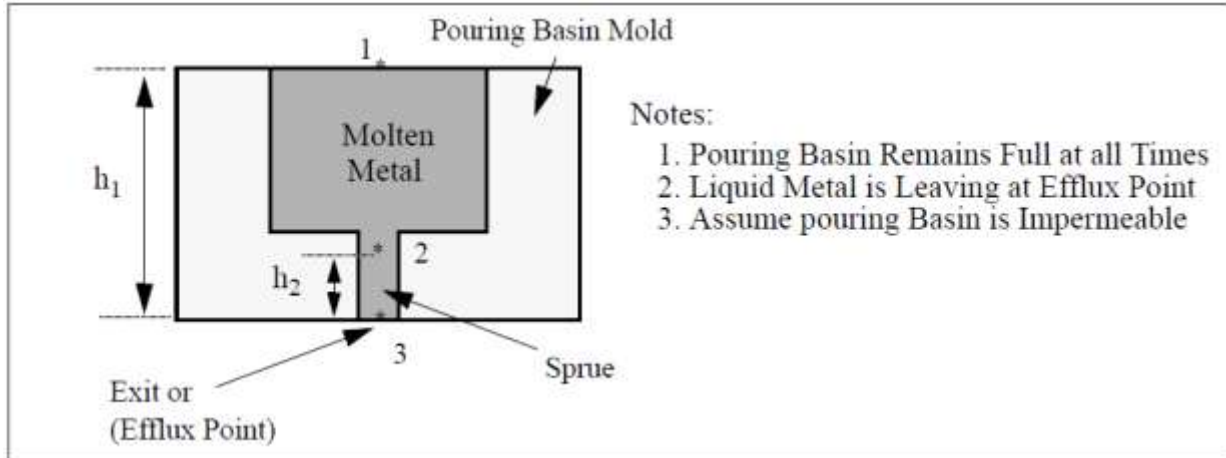
a). An allowance for the solid state shrinkage that will always accompany the casting as it cools from the melting temperature to room temperature. This will depend upon the metal being cast, each of which will have its own unique coefficient of thermal expansion, α . For example, α for aluminum at 20 °C is 23.9×10^{-6} in/in/°C, for iron is 11.7×10^{-6} in/in/°C and that for copper is 16.5×10^{-6} in/in/°C (see page 50 - 51). Thus the linear dimensions of the pattern will always be larger than the casting by an amount determined by the linear expansion coefficient. Of course the expansion coefficients for each of the above materials will change somewhat with temperature and so the pattern maker will usually give a generous allowance to cover the temperature dependence of the expansion coefficient.

b). Inclusion of a draft angle so that the pattern can be removed from the mold (or in the case of die casting or permanent mold casting, so the casting can be removed from the metal die) after the molding sand has been rammed around the pattern. These draft angles can vary from enough extra stock to allow for variations in casting dimensions due to mold preparation, pattern wear, etc. This amount will depend greatly upon the casting process being employed. For example the amount of "extra" stock will be typically greater for a sand casting than for a die casting. Machining and process tolerances are typically greater for sand castings than for permanent mold castings.

Details on pattern making can be found in several publications from the American Foundry Society (AFS).

6.2 Fluid Flow and Gating Design

A major factor in making a good casting is the ability to get the metal from the container into the mold with a minimum of turbulence, slag, entrapped sand or other materials in the mold or molten metal system which could get swept into the mold cavity. Accomplishing this task consistently requires a basic understanding of fluid flow principles as well as the insight provided by experience. Consider the following simple fluid flow system.



Law of Conservation of Mass

Along a line of flow matter is conserved so that

$$A_2 v_2 = A_3 v_3$$

where A_2 and A_3 are the cross sectional areas at points 2 and 3 and v_2 and v_3 are the fluid velocities at points 2 and 3.

Law of Conservation of Energy (Bernoulli's Law)

Energy, E , along a line of flow in a fluid can be expressed as:

$$E = h + v^2/2g + P/\rho + z$$

where:

E = energy in units of length (for ease of calculation)

h = Potential Energy or Head

$v^2/2g$ = Kinetic Energy

z = Catch-all term Containing Energy Losses due to Friction, Turbulence, Heat Loss

h = distance, in.

v = velocity, in/sec

g = acceleration of gravity, 384 in / sec²

P = Pressure, lbs / in²

ρ = Density, lbs / in³

Ideally the catch-all term z is equal to zero. However it will become clear from homework related to laboratory experimentation that it is a very significant item indeed. Bernoulli's Law states that energy is conserved along a line of flow, so that at any two points:

$$E_1 = E_2$$

$$\text{and therefore } h_1 + v_1^2/2g + P_1/\rho = h_2 + v_2^2/2g + P_2/\rho$$

In gating systems in sand molds the dependent variables of velocity, v , and pressure, P , are critical parameters which are important to control in filling a mold cavity quickly and cleanly. Examples of how velocity and pressure calculations can be utilized in gating design are given below.

Velocity at the Efflux Point

The velocity of flow within a gating system will determine the time required to fill a mold cavity. Using Bernoulli's Law at points 1 and 3 gives:

$$h_1 + v_1^2/2g + P_1/\rho = h_3 + v_3^2/2g + P_3/\rho.$$

Using the convention that the head is measured relative to the Efflux point, then $h_3 = 0$. Assuming that the system is operating in normal conditions of 1 atmosphere, then the free surfaces at points 1 and 3 require that $P_1 = P_3 = 14.7 \text{ lbs/in}^2$. Finally the assumption is always made that the pouring basin remains full so that at point 1, $v_1 = 0 \text{ in/sec}$. Therefore Bernoulli's Law reduces for points 1 and 3 to:

$$v_3 = (2gh)^{1/2}$$

$$\text{or } v_3 = 27.1 (h)^{1/2}$$

This velocity would also represent the velocity at the ingate in a so-called "pressurized" gating system, a system in which the smallest cross sectional area (the choke) occurs at the ingate. In this situation, then, the above velocity equation can be used to estimate mold cavity filling time, t_F .

$$t_F = (\text{Volume of Casting}) / (v_i A_i)$$

A typical gating system contains a pouring basin, a downsprue, a sprue well, a runner (usually in the drag), and ingates (usually in the cope on the parting line of the casting). This system is illustrated below for a **riserless** casting together with a calculation which uses the above velocity relationship to estimate casting filling time.

	<p>Ingate(Area, A_i) $A_S : A_R : A_i = 1 \text{ in}^2 : 2 \text{ in}^2 : 0.5 \text{ in}^2$ Problem: Assuming Bernoulli's Law holds with no losses due to friction, etc., compute the filling time of the casting given. Solution: Because the ingate represents the smallest cross sectional area of the system, and because the ingate is always at atmospheric pressure, the velocity at the ingate is constant and given by: $v_i = 27.71 (9)^{1/2}$ or $v_i = 83.13 \text{ in/sec}$ The time required to fill the casting is then $t_F = \text{Casting Volume} / v_i A_i$ $t_F = 96 / (83.13 \times 0.5) = 2.31 \text{ sec}$</p>
--	--

The above ratio of sprue base area to runner cross sectional area to ingate area is called the gating ratio, a common way to quantitatively describe gating systems. Filling

times for just such a casting has been experimentally measured at Michigan Tech for a number of years in which the head (Distance from top of pouring basin to the parting line) and the ingate cross sectional area were independently varied to control flow rates

Pressure at Intermediate Point in Gating System

It is important to keep the actual pressure within a flowing liquid in a sand mold above atmospheric pressure. If the pressure in the molten metal drops below 1 atmosphere then air can be drawn in or “aspirated” into the metal stream, thereby increasing the opportunity for defects within the casting. These defects could include the formation of metal oxides or gas porosity, a particularly troublesome problem in aluminum alloy castings which absorb hydrogen so readily in the liquid state. Consider the situation in the simple pouring basin sketch on page 39. Let us assume that the downsprue has the same cross sectional area at points 2 and 3. From the law of continuity then $v_2 = v_3$. Writing Bernoulli’s Law at points 2 and 3 gives:

$$h_2 + v_2^2/2g + P_2/\rho = h_3 + v_3^2/2g + P_3/\rho.$$

Solving for P_2 subject to the straight-sided sprue constraint gives:

$$P_2 = P_3 - h_2\rho.$$

Thus it can be seen that the pressure at point 2 is less than 1 atmosphere; gas aspiration will occur at this point in the system.

The number of gates needed to fill a casting cavity in an acceptable time is determined by the size of the casting as well as the casting complexity, both factors which are dealt with using experience and a certain amount of common sense.

6.3 Shrinkage, Riser Design

Risers are used in the production of castings for the purpose of providing molten metal for the solidifying and shrinking casting. Riser design in sand castings requires, at a minimum, that the riser solidify after the casting. A casting and riser are shown schematically in a sand mold below. The desired situation after solidification would result in all the shrinkage within the riser as illustrated in fig 26.

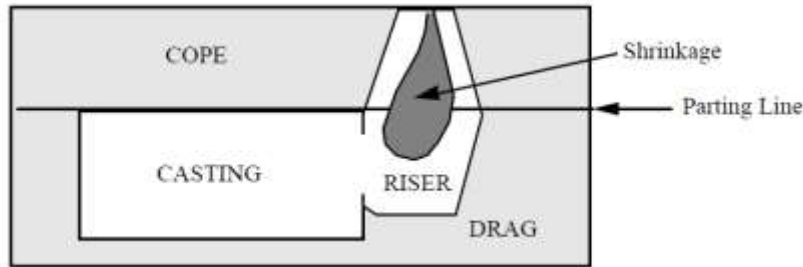
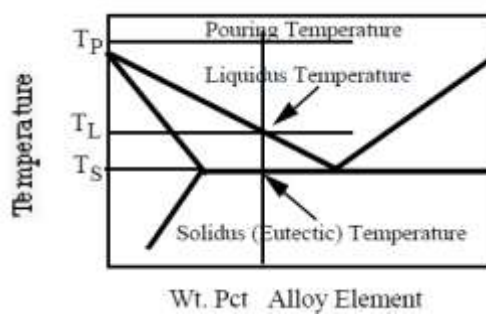


Fig 26 Schematic diagram of Shrinkage

Shrinkage in Metals during Solidification

The shrinkage that occurs during solidification of metals (that ideally all ends up in the shrinkage cavity in the riser shown above) results from three distinct contributions which are illustrated below for an alloy in a eutectic system which solidifies over a temperature range (most alloys do not solidify at one temperature).



SHRINKAGE COMPONENTS

- I. Thermal Contraction of L from T_P to T_L
- II. Thermal Contraction of Liquid and Solid from T_L to T_S
- III. Change in State from Liquid to Solid from T_L to T_S and at T_S

Fig 27 Shrinkage in Metals

The total amount of shrinkage experienced during solidification may be quite large, especially for aluminum alloys, which can shrink 6.5% during the change in state. The number of risers needed to effectively feed a casting depends upon casting geometry and feeding distance required.

Riser design in sand mold castings requires, as a minimum, that the riser solidify after the casting, i.e.:

$$t_S(\text{Riser}) > t_S(\text{Casting})$$

Thus by Chvorinov's Rule,

$$B_S(\text{R})\{V/A\}_R^2 > B_S(\text{C})\{V/A\}_C^2$$

where $B_S(\text{R})$ and $B_S(\text{C})$ are the mold constants for the riser and casting respectively, and $(V/A)_R$ and $(V/A)_C$ are the volume to area ratios of the riser and casting respectively. It is useful to define the ratio (V/A) as the modulus, M , so that,

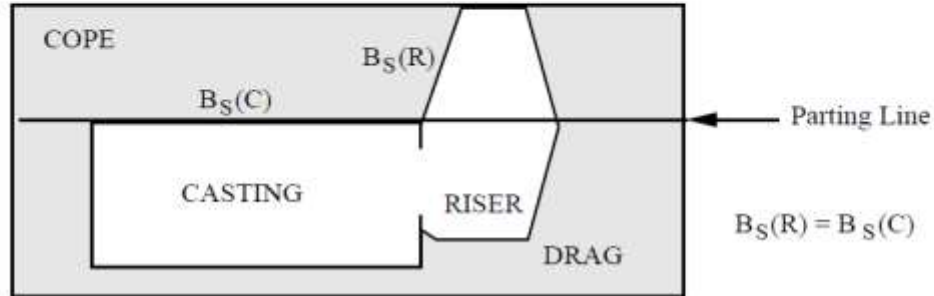
$$(V/A)_R = M_R \text{ (Modulus of Riser), and } (V/A)_C = M_C \text{ (Modulus of Casting)}$$

Thus for successful riser design,

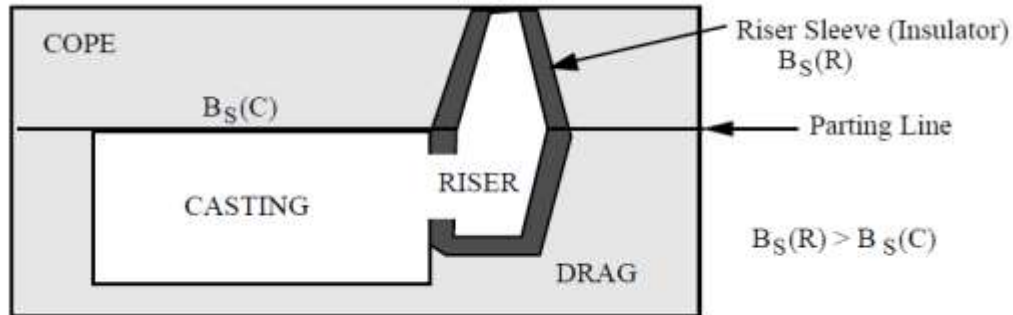
$$B_S(\text{R}) (M_R)^2 > B_S(\text{C}) (M_C)^2$$

It is clear on studying this equation that any of the terms present could, in principle, be varied independently to insure that $t_S(\text{R}) > t_S(\text{C})$. However, there are two most likely situations encountered in practice, situations defined below:

- I. $B_S(\text{R}) = B_S(\text{C})$, and then $M_R > M_C$ becomes the criterion that must be met to insure that the riser solidify after the casting. This is by far the most common situation encountered in practice, the situation in which the riser and the casting are molded into the same sand. In practice it has been observed that $M_R > 1.1 M_C$ is usually sufficient to effectively feed the solidifying casting. This situation is illustrated below:



II. $B_S(R) > B_S(C)$, such that $M_R < M_C$ and still the inequality $t_S(R) > t_S(C)$ is obeyed. This is the situation when an insulating riser sleeve is molded around the riser cavity. This allows a much smaller riser to be utilized thereby increasing casting yield (see page 59 for a definition of casting yield). This is illustrated below:



6.4 Design Recommendations for Casting

1. Compensate the shrinkage of the solidified molten metal by making patterns of slightly oversize.
2. In sand casting, it is more economical and accurate if the parting line is on a flat plane [Fig 28(a)]. Contoured parting lines are not economical. Further, some degree of taper, or draft is recommended to provide to the pattern for its easy removal [Fig 28(b)]. The recommended draft angles for patters under various conditions are given elsewhere.
3. In sand casting, it is recommended to attach the raiser near to the heavier section. The thinnest sections are farthest from the raiser and solidify first and then the solidification proceeds toward the direction of raiser i.e. towards the heavier section [Fig 28(c)].
4. Sharp corners in a casting design cause uneven cooling and lead to formation of hot spots in the final cast structure. Moreover sharp corner in a casting structure acts as a stress raiser. Rounding the corner decreases the severity of the hot spot and lessens the stress concentration [Fig 28(d)].
5. Abrupt changes in sections should be avoided. Fillets and tapers are preferable to sharp steps [Fig 28(e)].

6. The interior walls and sections are recommended to be 20% thinner than the outside members to reduce the thermal and residual stresses, and metallurgical changes [Fig 28(f)].
7. When a hole is placed in a highly stressed section, add extra material around the hole as reinforcement [Fig 28(g)].
8. To minimize the residual stresses in the gear, pulley or wheel casting, a balance between the section size of the rim, spokes and hub is maintained [Fig 28 (h)].
9. An odd number of curved wheel spokes reduce cast-in-residual stresses [Fig 28(i)].
10. Similar to sand casting, permanent mold castings also require draft for the easy withdrawal of the casting from the mold. The recommended draft angles are given elsewhere.
11. Due to pattern shrinkage, investment shrinkage and metal shrinkage during solidification, there is always a tendency for an investment part to “dish” (develop concave surfaces where flat surfaces are specified). This condition takes place in areas of thick cross section. Dishing is minimized by designing parts with uniformly thin walls [Fig 28(j)].


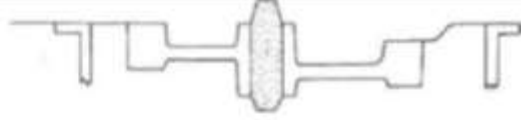
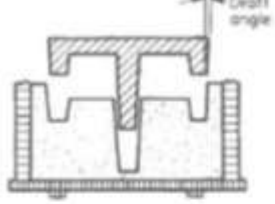
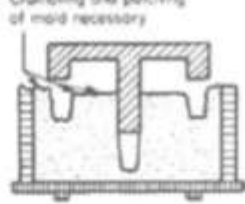


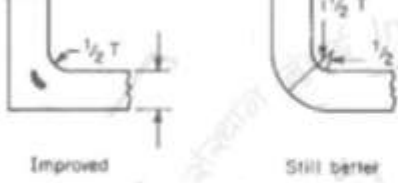
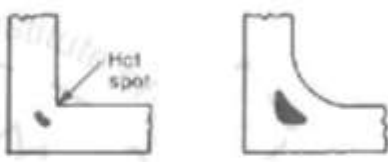
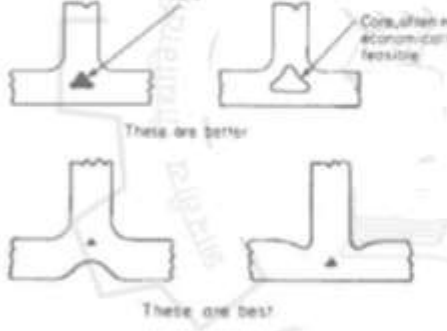
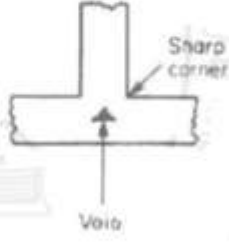
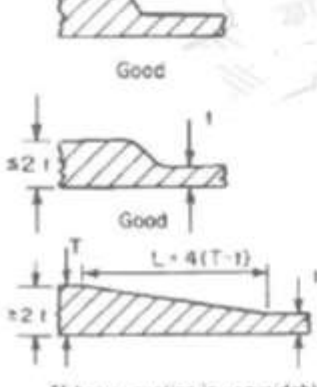
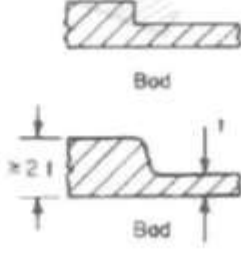
Fig. no.	Recommended	Not recommended
(a)		
(b)	 <p>Draft angle</p>	 <p>Crumbing and patching of mold necessary</p>
(c)		
(d)	 <p>Improved</p> <p>Still better</p>	 <p>Hot spot</p>
	 <p>Void</p> <p>Consulted with economically feasible</p> <p>These are better</p> <p>These are best</p>	 <p>Sharp corner</p> <p>Void</p>
(e)	 <p>Good</p> <p>Good</p> <p>Good</p> <p>$\approx 2t$</p> <p>t</p> <p>$L = 4(T-t)$</p> <p>If heavy section is unavoidable, use 4:1 taper.</p>	 <p>Bad</p> <p>Bad</p> <p>$\approx 2t$</p> <p>t</p>

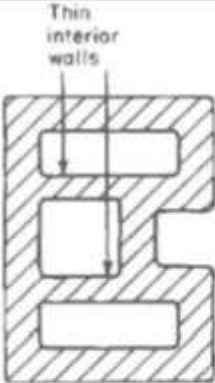
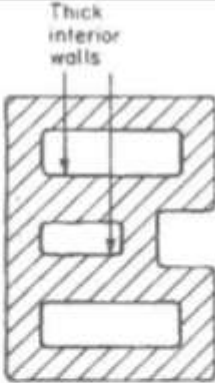

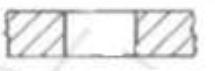

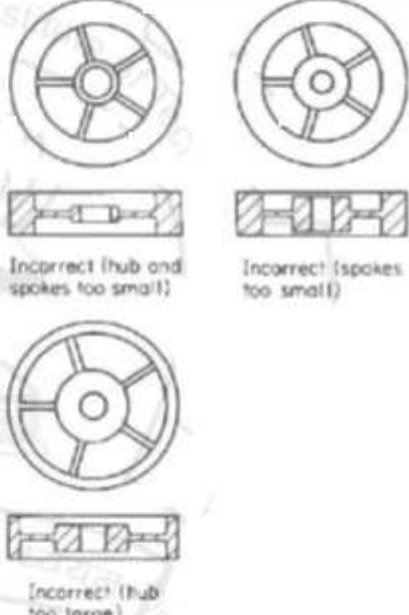

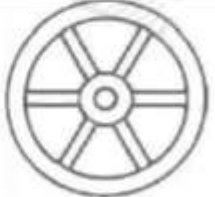
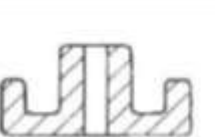
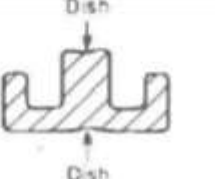
Fig. no.	Recommended	Not recommended
(f)		
(g)		
(h)	 <p data-bbox="347 1157 560 1207">Correct (balanced size of elements)</p>	 <p data-bbox="868 997 1047 1039">Incorrect (hub and spokes too small)</p> <p data-bbox="1096 997 1274 1039">Incorrect (spokes too small)</p> <p data-bbox="868 1323 1047 1365">Incorrect (hub too large)</p>
(i)		
(j)		

Figure 28 Recommended designs for casting

12. When keys and keyways are required, the recommended ratio of width to depth is 1.0 or more. The minimum castable key width is 2.3 mm for ferrous metals and 1.5 mm for nonferrous metals [Figure 29].
13. Heavy bosses connecting to the surface can cause “sinks” due to the shrinkage of the large mass of the metal in the boss during cooling. This shrinkage problem can be reduced by moving the boss away from the surface and connecting it to the surface with a short rib [Figure 30].

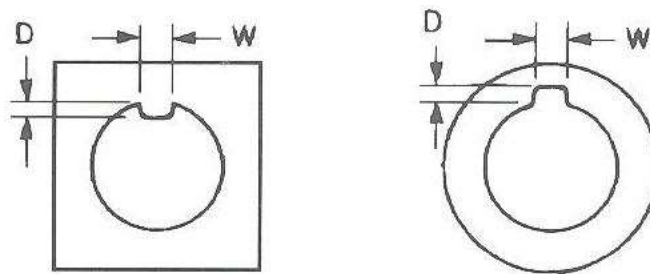


Figure 29 The recommended casting design for key and key ways for (a) ferrous metal, (b) Non-ferrous metal

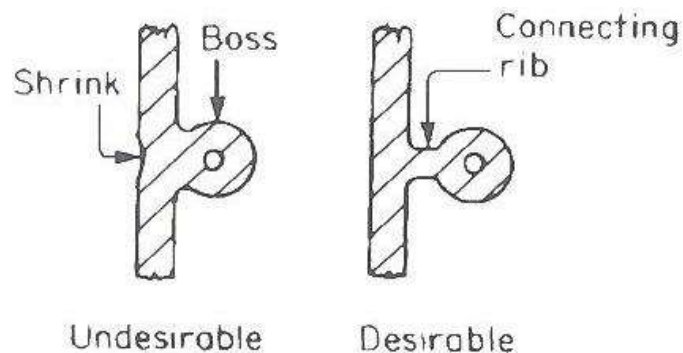


Figure 30 The recommended cast design to avoid surface shrink

7. **Waste management** in a testing foundry includes control, appropriate collecting, manipulation, storage, and removal of the waste, which is produced in casting process. The basic goal of the waste management is to define, and organize individuals, who are responsible for performing of particular procedures on such a way that human health is not in danger and with such methods, which reduce

environment pollution to minimum. It is especially important to prevent: • excessive air, water and soil polluting, • spreading bad odors and noise, • substantially deterioration of living conditions, and • bad influence on environment in the region.

In the testing foundry, formation of waste and environment pollution by manufacturing processes could be divided into the following groups: • waste gases emissions, • waste material emissions, • emissions of heat into environmental water, and • noise

Foundry management is because characteristic unclean production, which cause different influences on people, atmosphere, water, soil, vegetal and animal world in constant contact with ecological experts and make every effort to minimized those influences.

Waste management in foundries is gaining a higher ecological and economical importance. Waste is becoming an increasingly traded product, where excellent profits can be made. Due to the cost reduction and successful business operation in companies, waste has to be regenerated and used again as a material to the maximum possible extent. From the sustainable development point of view, waste management is most suitable since it ensures the material utilization of the waste reduces the consumption of natural renewable or non-renewable resources and makes efficient production capacity utilization possible. Sand, dust, slag and other mineral waste from foundries are increasingly being used as materials in other industries. The foundry Feniks was awarded with certification of the environmental management system according to the standard SIST EN ISO 14001 and confirmed its environmental credentials

8. Introduction to Arc Welding

A welding arc is an electric discharge that develops primarily due to flow of current from cathode to anode. Flow of current through the gap between electrode and work piece needs column of charged particles for having reasonably good electrical conductivity. These charged particles are generated by various mechanisms such as thermal emission, field emission secondary emission etc. Density of charged particles in gap governs the electrical conductivity of gaseous column. In an electric arc, electrons released from cathode (due to electric field or thermo-ionic emission) are accelerated towards the anode because of potential difference between work piece and electrode. These high velocity electrons moving from cathode toward anode collide with gaseous molecules and decompose them into charged particles i.e. electrons and ions. These charged particles move towards electrode and work piece as per polarity and form a part of welding current. Ion current becomes only about 1% of electron current as ions become heavier than the electrons so they move slowly. Eventually electrons merge into anode. Arc gap between electrode and work piece acts as pure resistance load. Heat generated in a welding arc depends on arc voltage and welding current.

8.1 Coated Electrodes are specified based on core wire diameter. Commonly used electrode diameters are 2, 2.5, 3.18, 4, 5 and 6 mm. Length of electrodes may depend on diameter of core wire ranging from 250 to 450 mm i.e. larger the core diameter larger the length. However, special electrodes may be of 8-10 mm diameter. Table 5.2 gives the details of electrode sizes and currents.

The electrodes are also specified based on ratio of diameter of coated portion of electrode to core wire diameter. If this ratio is lesser than 1.2 then electrodes are thin coated, if ratio ranges between 1.2 to 1.5 then medium coated and if ratio exceeds 1.5 then electrodes are heavy coated or thick coated. This ratio may vary slightly in different codes. Thin coated electrodes have very good bridgeability at the joint gap but weld bead has coarse ripples and penetration is also poor. Medium coated electrodes lead to reasonably good bridgeability, medium ripples in weld bead and modest penetration.

Thick coated electrodes have poor bridgeability, however, bead appearance is excellent with fine ripples and also excellent penetration.

The ingress of oxygen and nitrogen from the atmosphere to the weld pool and arc environment would cause embrittlement and porosity in the weld metal and this must be prevented. The Actual method of arc shielding from atmospheric nitrogen and oxygen attack varies with different type of electrodes which are in two main categories.

1. Bulk of covering material converts to a gas by the heat of the arc, only a small amount of slag is produced. Protection depends largely upon a gaseous shield to prevent atmospheric contamination as in case of cellulosic electrode.

2. Bulk of covering material converts to a slag, only a small volume of shielding gas produced as in the case of rutile and basic coated electrodes.

Electrode coating performs many functions depending upon coating constituents, during welding to improve weld metal properties. The important functions are as follows:

1. Improve the electric conductivity in the arc region to improve the arc ignition and stabilization of the arc.
2. Formation of slag, which;
 - (a) Influences size of droplet.
 - (b) Protects the droplet during transfer and molten weld pool from atmospheric gases.
 - (c) Protects solidified hot metal from atmospheric gases.
 - (d) Reduces the cooling rate of weld seam.
3. Formation of shielding gas to protect molten metal.
4. Provide deoxidizers like Si and Mn in form of FeSi and FeMn.
5. Alloying with certain elements such as Cr, Ni, Mo to improve weld metal properties.
6. Improve deposition rate with addition of iron powder in coating.

Various constituents of electrode coating are cellulose, calcium fluoride, calcium carbonate, titanium dioxide, clay, talc, iron oxide, asbestos, potassium / sodium silicate, iron powder, ferro-manganese, powdered alloys, silica etc. Each constituent performs either one or more than one functions.

Electrode metallic core wire is the same but the coating constituents give the different characteristics to the welds. Based on the coating constituents, structural steel electrodes can be classified in the following classes;

1. Cellulosic Electrodes

Coating consists of high cellulosic content more than 30% and TiO₂ up to 20%. These are all position electrodes and produce deep penetration because of extra heat generated during burning of cellulosic materials. However, high spatter losses are associated with these electrodes.

2. Rutile Electrodes

Coating consists of TiO₂ up to 45% and SiO₂ around 20%. These electrodes are widely used for general work and are called general purpose electrodes.

3. Acidic Electrodes

Coating consists of iron oxide more than 20%. Sometimes it may be up to 40%, other constituents may be TiO₂ 10% and CaCO₃ 10%. Such electrodes produce self detaching slag and smooth weld finish and are used normally in flat position.

4. Basic Electrodes

Coating consist of CaCO₃ around 40% and CaF₂ 15-20%. These electrodes normally require baking at temperature of approximately 250 ° C for 1-2 hrs or as per manufacturer's instructions. Such electrodes produce high quality weld deposits which has high resistance to cracking. This is because hydrogen is

removed from weld metal by the action of fluorine i.e. forming HF acid as CaF₂ generates fluorine on dissociation in the heat of arc.

Classification of Electrodes as per Indian Standard:

Structural steel electrodes were classified as per IS 814:1974 and this code was revised and the revised code is IS 814:1991.

The corresponding code is given on each packet of electrode.

IS 815:1974

As per IS 815 electrodes are designated with letters and digits.

P X X X X X X S

Prefix (P) is either E or R which indicates solid extruded (E) or reinforced extruded (R) Electrode.

1 st digit – Indicates type of coating.

2 nd digit – Indicates weld positions in which electrode can be used.

3 rd digit – Indicates welding current conditions.

4 th and 5 th digit – Indicate UTS and YS of all weld metal.

6 th digit – Requirement of minimum % elongation and absorbed energy in charpy V- notch impact test of weld metal.

Suffix (s) – P – Deep penetration electrode

H – Hydrogen controlled electrode

J, K and L – Amount of metal recovery in case of iron powder electrode

Suffix (s) are optional and may or may not be given if not applicable.

IS 814:1991

As per IS 814 electrodes are designated with letters and digits as given below:

E L X X X X S

In this code E indicates extruded solid electrode, L is a letter to designate type of coating, first digit indicates UTS and YS of deposited weld metal, second digit gives percentage elongation and impact values of weld metal deposited, third digit gives welding positions in which electrode can be used and fourth digit gives the current conditions for the use of electrode.

Suffix(s) are optional and indicate special characteristics of electrode such as H1, H2, and H3 indicate hydrogen controlled electrodes with different amount of diffusible hydrogen J, K, L indicate different amount of metal recovery in weld pool in case of iron powder electrodes and X means radiographic weld quality.

8.2 Emission of Free electrons

Free electrons and charged particles are needed between the electrode and work for initiating the arc and their maintenance. Ease of emitting electrons by a material assessed on the basis of two parameters work function and ionization potential.

Emission of electrons from the cathode metal depends on the work function. The work function is the energy (ev or J) required to get one electron released from the surface of material. Ionization potential is another measure of ability of a metal to emit the electrons and is defined as energy/unit charge (v) required for removing an electron from an atom. Ionization potential is found different for different metal. For example, Ca, K, and Na have very low ionization potential (2.1-2.3ev), while that for Al and Fe is on the higher side with values of 4 and 4.5 ev respectively. Common mechanisms through which free electrons are emitted during arc welding are described below:

Thermo-ionic emission

Increase in temperature of metal increases the kinetic energy of free electrons and as it goes beyond certain limit, electrons are ejected from the metal surface. This mechanism of emission of electron due to heating of metal is called thermo ionic emission. The temperature at which thermo-ionic emission takes place, most of the metals melt. Hence, refractory materials like tungsten and carbon, having high melting point exhibit thermo ionic electron emission tendency.

Field emission:

In this approach, free electrons are pulled out of the metal surface by developing high strength electro-magnetic field. High potential difference (107 V/cm) between the work piece and electrode is established for the field emission purpose.

Secondary emission

High velocity electrons moving from cathode to anode in the arc gap collide with other gaseous molecules. This collision results in decomposition of gaseous molecules into atoms and charged particles (electrons and ions).

Zones in Arc Gap

On establishing the welding arc, drop in arc voltage is observed across the arc gap. However, rate of drop in arc voltage varies with distance from the electrode tip to the weld pool (Fig. 5.1). Generally, five different zones are observed in the arc gap namely cathode spot, cathode drop zone, plasma, anode drop zone and anode spot (Fig. 5.2).

Cathode spot

This is a region of cathode wherefrom electrons are emitted. Three types of cathode spots are generally found namely mobile, pointed, and normal. There can be one or more than one cathode spots moving at high speed ranging from 5-10 m/sec. Mobile cathode spot is usually produced at current density 100-1000 A/mm². Mobile cathode spot is generally found during the welding of aluminium and magnesium. This type of cathode spot loosens the oxide layer on reactive metal like aluminium, Mg and stainless steel. Therefore, mobile cathode spot helps in cleaning action when reverse polarity is used i.e. work piece is cathode. Pointed cathode spot is formed at a point only mostly in case of tungsten inert gas welding at about 100A/mm². Pointed tungsten electrode forms the pointed cathode-spot. Ball shaped tip of coated steel electrode forms normal cathode spot.

Cathode drop region:

This region is very close to the cathode and a very sharp drop of voltage takes place in this zone due to cooling effect of cathode. Voltage drop in this region directly affects the heat generation near the cathode which in turn governs melting rate of the electrode in case of the consumable arc welding process with straight polarity (electrode is cathode).

Plasma:

Plasma is the region between electrode and work where mostly flow of charged particles namely free electrons and positive ions takes place. In this region, uniform voltage drop takes place. Heat generated in this region has minor effect on melting of the work piece and electrode.

Anode drop region:

Like cathode drop region, anode drop region is also very close to the anode and a very sharp drop in voltage takes place in this region due to cooling effect of the anode. Voltage drop in this region affects the heat generation near the anode & so melting of anode. In case of direct current electrode negative (DCEN), voltage drop in this zone affects melting of the work piece.

Anode spot:

Anode spot is the region of a anode where electrons get merged and their impact generates heat for melting. However, no fixed anode spot is generally noticed on the anode like cathode spot.

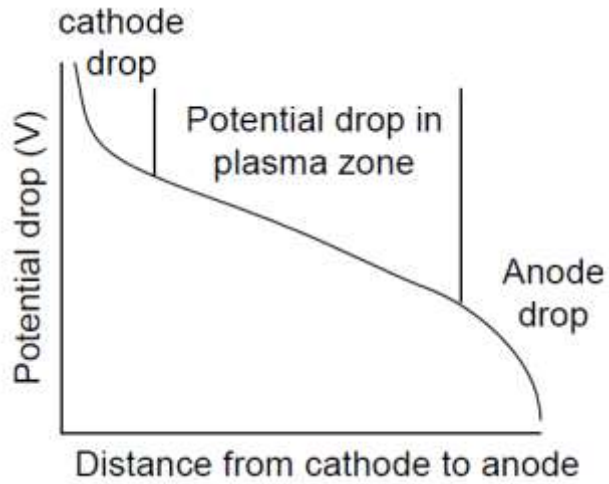


Fig. 31 Potential drop as function of distance from the cathode to anode

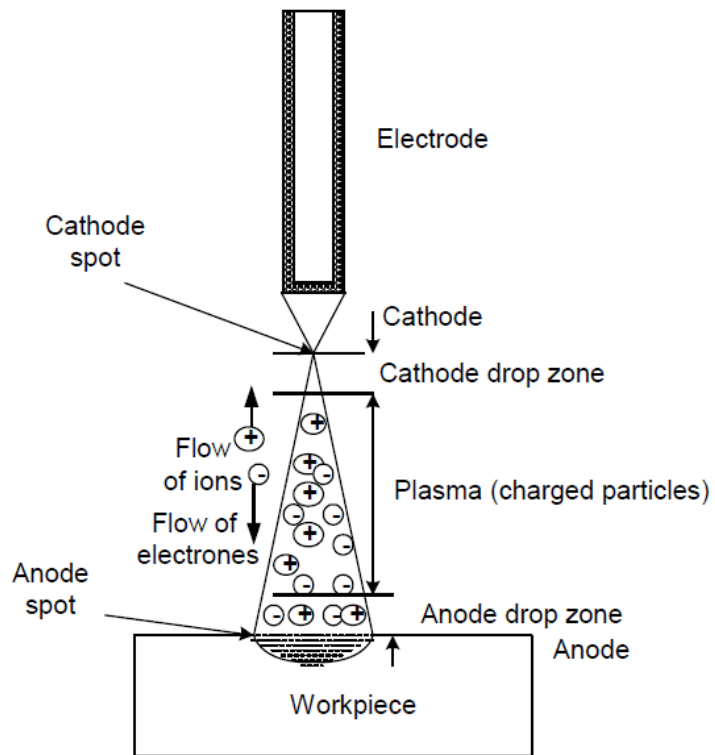


Fig. 32 Zones in arc gap of a welding arc

8.3 Electrical Fundamentals of Welding Arc

The welding arc acts as impedance for flow of current like an electric conductor. The impedance of arc is usually found a function of temperature and becomes inversely proportional to the density of charge particles and their mobility. Therefore, distribution of charged particles in radial and axial direction in the arc affects the total impedance of the arc. Three major regions have been noticed in arc gap that accounts for total potential drop in the arc i.e. cathode drop region, plasma and anode drop region. Product of potential difference across the arc (V) and current (I) gives the power of the arc indicating the heat generation per unit time. Arc voltage (V) is taken as sum of potential drop across the cathode drop region (V_c), potential drop across the plasma region (V_p), and potential drop across the anode drop region (V_a) as shown in Fig. 33.

$$\text{Power of the arc (P)} = (V_c + V_p + V_a)$$

Potential drop in different zones is expressed in terms of volt (V), welding current in ampere (A) and power of arc P is in watt (W). This equation suggests that the distribution of heat in three zones namely cathode, anode and arc plasma can be changed. Variation of arc length mainly affects plasma heat while shielding gas influences the heat generation in the cathode and anode drop zones. Addition of low ionization potential materials (namely potassium and sodium) reduces the arc voltage because of increased ionization in arc gap so increased electrical conductivity which in turn reduces the heat generation in plasma region. Heat generation at the anode and cathode drop zones is primarily governed by type of welding process and polarity associated with welding arc. In case of direct current (DC) welding, when electrode is connected to the negative terminal and workpiece is connected with positive terminal of the power source then it is termed as directcurrent electrode negative polarity (DCEN) or straight polarity and when electrode is connected to the positive terminal of the power source and workpiece is connected with negative terminal then it is termed as direct current electrode positive polarity (DCEP) or reverse polarity. TIG welding with argon as shielding gas shows 8-10 time higher current carrying capacity (without melting) than DCEP. The submerged arc welding with DCEP generates larger amount of heat at

cathode than anode as indicated by high melting rate of consumable electrode. Increase in spacing between the electrode and work-piece generally increases the potential of the arc because of increased losses of the charge carriers by radial migration to cool boundary of the plasma. Increase in the length of the arc column (by bulging) exposes more surface area of arc column to the low temperature atmospheric gas which in turn imposes the requirement of more number of charge carriers to maintain the flow of current. Therefore, these losses of charged particles must be accommodated to stabilize the arc by increasing the applied voltage. The most of the heat generated in consumable arc welding process goes to weld pool which in turn results in higher thermal efficiencies. This is more evident from the fact that the thermal efficiency of metal arc welding processes is found in range of 70- 80% whereas that for non-consumable arc welding processes is found in range of 40-60%.

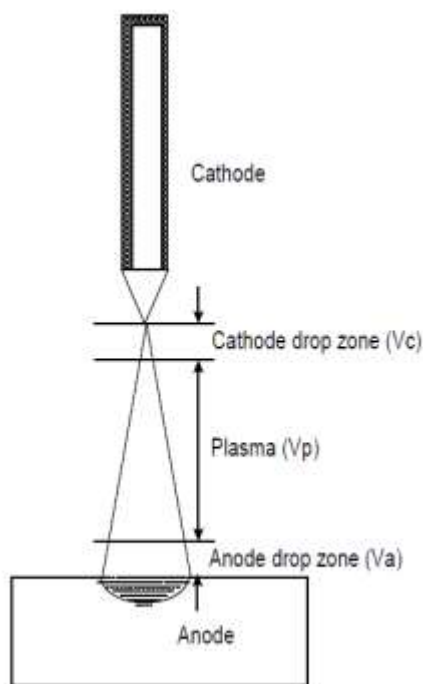


Fig. 33 Three different zone in which voltage drop takes place

Arc Initiation

There are two most commonly used methods to initiate an electric arc in welding processes namely touch start and field start. The touch start method is used in case of all common welding processes while the later one is preferred in case of automatic

welding operations and in the processes where electrode has tendency to form inclusion in the weld metal like in TIG welding or electrode remains inside the nozzle.

Touch Start

In this method, the electrode is brought in contact with the work piece and then pulled apart to create a very small gap. Touching of the electrode to the work piece causes short-circuiting resulting in flow of heavy current which in turn leads to heating, partial melting and even slight evaporation of the metal at the electrode tip. All these events happen in very short time usually within few seconds (Fig. 34 a, b). Heating of electrode produces few free electrons due to thermal ionization; additionally dissociation of metal vapours (owing to lower ionization potential of the metal vapours than the atmospheric gases) also produces charged particles (electron and positively charged ions). On pulling up of the electrode apart from the work piece, flow of current starts through these charged particles and for a moment arc is developed. To use the heat of electric arc for welding purpose it is necessary that after initiation of arc it must be maintained and stabilized.

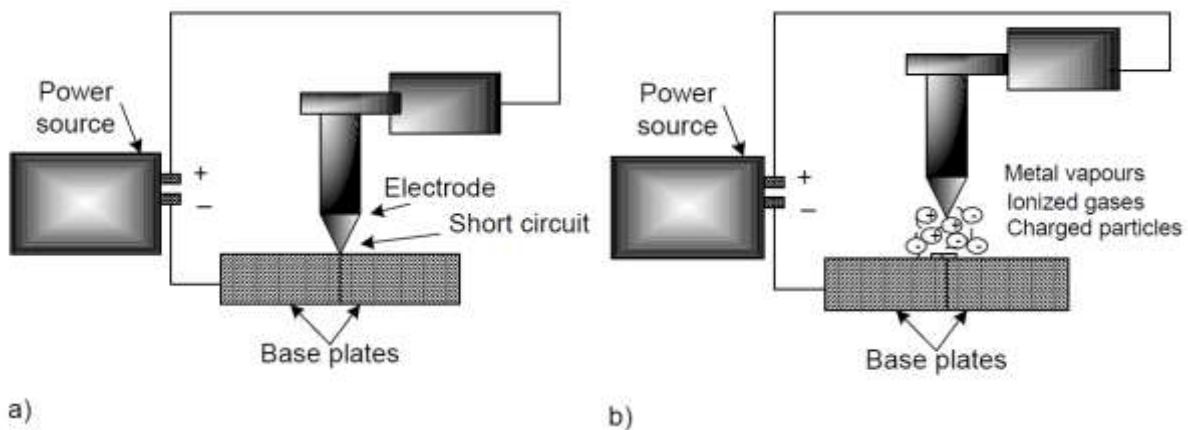


Fig. 34 Schematic diagram showing mechanism of arc initiation by touch start method
a) when circuit closed by touching electrode with work piece b) emission of electrode on putting them apart

Field Start

In this method, high strength electric field (107 V) is applied between electrode and work piece so that electrons are released from cathode electro-magnetic field emission (Fig. 35). Development of high strength field leads to ejection of electron from cathode spots. Once the free electrons are available in arc gap, normal potential difference between electrode and work piece ensures flow of charged particles to maintain a welding arc. This method is commonly used in mechanized welding processes such as plasma arc and GTAW process where direct contact between electrode and work piece is not preferred.

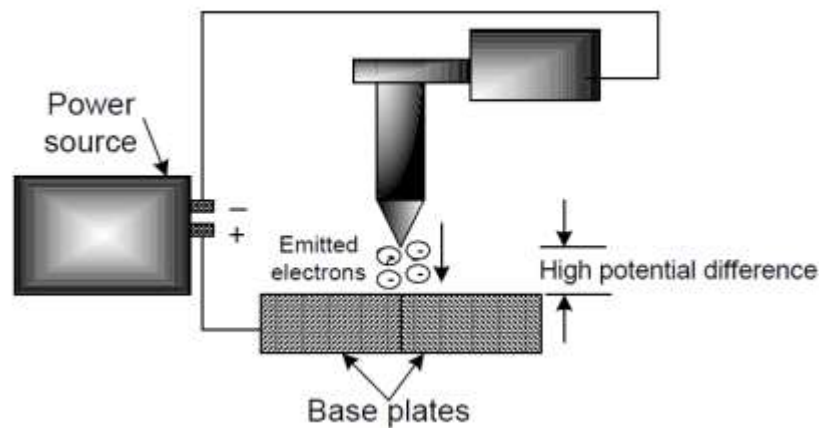


Fig. 35 Schematic diagram showing the field-start method of arc initiation

Maintenance of Arc

Once electric arc is initiated, next step is to maintain it to use the heat generated for welding purpose. For maintaining of the arc two conditions must be fulfilled (1) heat dissipation rate from the arc, region should be equal to that of heat generated to maintain the temperature of the arc and (2) number of electrons produced should be equal to that of electrons lost to the work piece and surroundings.

An electric arc primarily involves flow of current through the gap between the work piece and electrode hence there must be sufficient number of charged particles namely electrons and ions. However, some of the electrons are lost from the arc surface, to the weld pool and surroundings and few electrons reunite with ions. Loss of these electrons must be compensated by generation of new free electrons. In case of direct current,

magnitude and direction of current does not change with time hence maintaining the flow of electrons and so the arc becomes easy while in case of alternating current (A.C.) both magnitude and direction change with time and for a moment flow of current becomes zero. This makes re-ignition of an electric arc with AC somewhat difficult and therefore it needs extra precautions and provisions. There are two commonly used methods for maintaining the arc in A.C. welding: (1) use of low ionization potential elements in coatings flux and (b) use of low power factor power source.

Low Ionization Potential Elements

In this method, low ionization potential elements such as potassium, calcium and sodium are added in the flux covering of the electrode (coating). These elements release free electrons needed to have reasonably good electrical conductivity for maintaining welding arc even with small potential difference between electrode and work piece (Fig. 36).

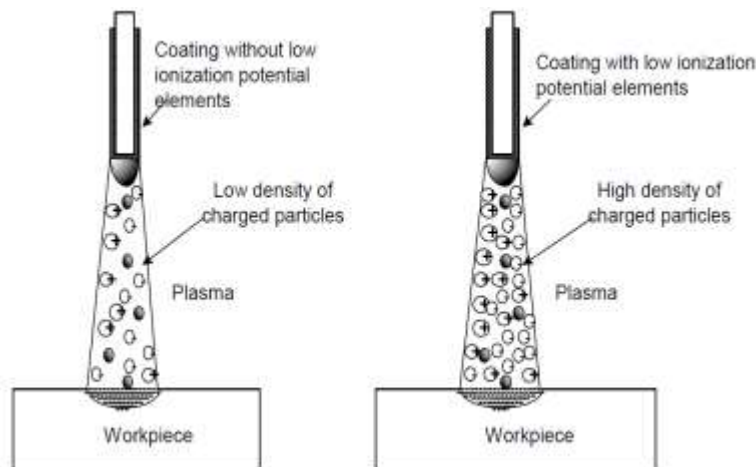


Fig. 36 Schematic representation of effect of low ionization potential elements on density of charged particles

Low Power Factor

Power factor of a system indicates how effectively power is being utilized and it is generally preferred to have high power factor of machine or system. Power factor is

defined as ratio of actual power drawn from the power source to perform the welding and apparent power drawn into the welding circuit line. Welding transformer operates at high power factor (>0.9). However, in welding usually low power factor is intentionally used to improve the arc stability and maintenance of welding arc. In this method, current and voltage are made out of phase by using proper low power factor (0.3) so that when current is zero, full open circuit voltage is available between electrode and work piece (Fig. 37). Full open circuit voltage across the electrode and work helps in release of free electrons to maintain flow of already existing electrons which is a prerequisite for maintenance of the arc.

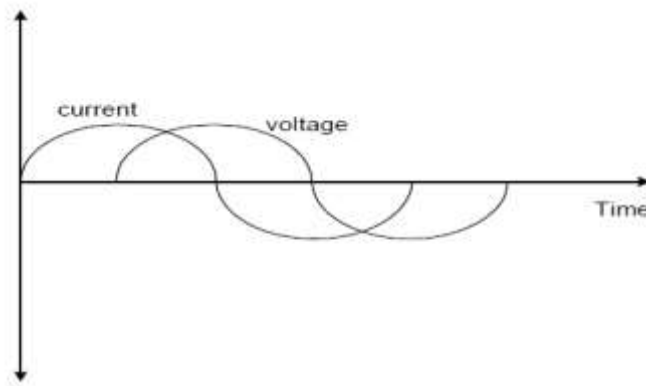


Fig. 37 setting proper power factor to have current and voltage out of phase

Arc Characteristic

Welding arc characteristic shows variation in the arc voltage with welding current. There are three different regions on the arc characteristic curve namely dropping, flat and rising characteristics zones (Fig. 38). Initially at low current when arc is thin, an increase in welding current increases the temperature of arc zone which in turn enhances the number of charged particles in plasma zone of the arc due to thermal ionization and thermo-ionic emission of electrons. As a result, electrical conductivity of arc zone increases which in turn decrease arc voltage decreases with initial increase in welding current in this zone. Arc tends to be stable in this region. This trend continues up to certain level of current and beyond that increase in current increases the diameter of cylindrical arc that increases the surface area of the arc. Increase in surface area of the

arc in turn increases loss of heat from the arc surface. Therefore, no significant rise in arc temperature takes place with increase of current hence arc voltage is not affected appreciably over a range of current in flat zone of the curve. Further, increase in current bulges the arc, which in turn increases the resistance to flow of current (due to increased losses of charge carriers and heat from arc) so arc voltage increases with increase in welding current in rising characteristic zone. These three zones of arc characteristic curve are called drooping, flat and rising characteristics. Increase in arc length in general increases arc voltage during welding. However, the extent of increase in arc voltage with increase in arc length varies with process as shown in Fig. 39. In general, arc voltage increases almost lineally with increase in arc length (within reasonable limits) and the same is attributed to increase in resistance to the flow of current due to reduction in charged particle density in arc zones with increase in arc length.

Variation in charged particle density in arc zones associated different arc welding processes such as SMAW, GMAW and GTAW is attributed to appreciable difference in arc voltage vs. arc length relationship (Fig. 39). For example, GTAW process due to tungsten electrode (having high electron emitting capability) results in higher charged particle density in arc region than GMAW and SMAW which in turn leads to lower arc voltage/arc length ratio for GTAW than LMAW & SMAW process.

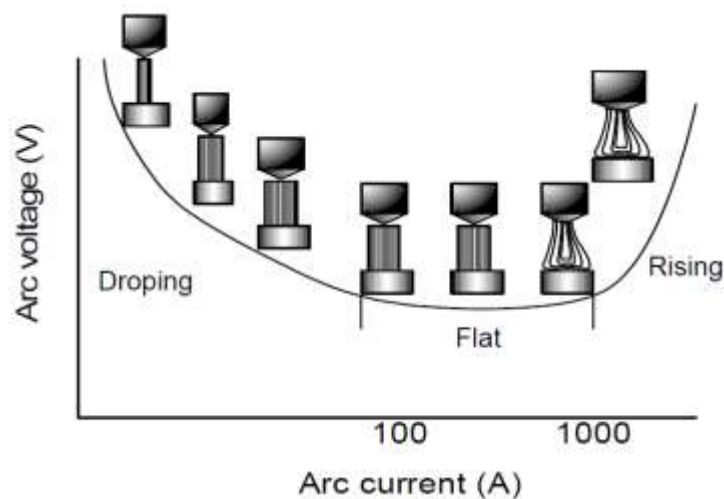


Fig. 38 Schematic diagram showing welding arc characteristic curve

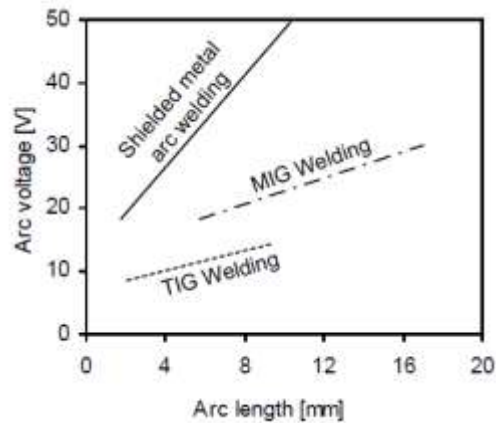


Fig. 39 Variation in arc voltage as function of arc length for different arc welding processes

Temperature of the Arc

In addition to arc voltage and current parameters (governing the power of arc), thermal properties (thermal conductivity) of shielding gases present in arc zone predominantly affect the temperature and its distribution in the arc region. Thermal conductivity of most of the gases (He, N, Ar) increases with rise in temperature however, this increase is not continuous for some of the gases such as Helium. Thermal conductivity of base metal/shielding gas governs temperature gradient in the arc region. Reduction in thermal conductivity increases the temperature gradient.

Therefore, a very rapid decrease in temperature of arc is observed with increase in distance from the axis (center) of the arc (Fig. 40). Maximum temperature is observed at core (along the axis of electrode) of the arc and it decreases rapidly with increase in distance away from the core. Temperatures in anode and cathode drop zones are generally lower than the plasma region due to cooling effect of electrode/work piece. Temperature of arc can vary from 5000-30,000K depending upon the current voltage shielding gas and plasma gas. For example, in case of SMAW, temperature of arc is about 6000K while that for TIG/MIG welding arc it is found in range of 20000-25000K.

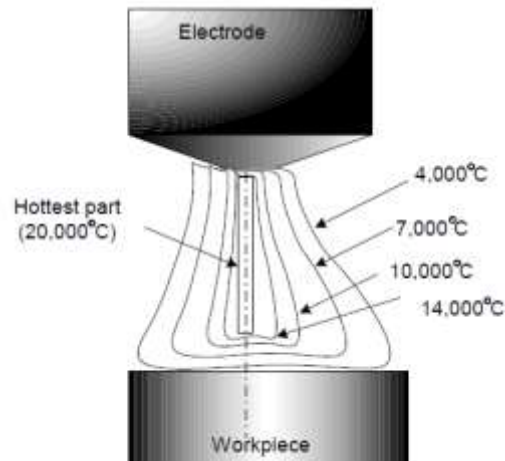


Fig. 40 Schematic diagram showing typical temperature distribution in the arc

8.4 Arc Efficiency

Arc welding basically involves melting of faying surfaces of base metal using heat generated by arc under a given set of welding conditions i.e. welding current and arc voltage. However, only a part of heat generated by the arc is used for melting purpose to produce weld joint and remaining is lost in various ways namely through conduction to base metal, by convection and radiation to surrounding (Fig. 41). Moreover, the heat generation on the work piece side depends on the polarity in case of DC welding while it is equally distributed in work piece and electrode side in case of AC welding. Further, it can be recalled that heat generated by arc is dictated by the power of the arc (VI) where V is arc voltage i.e. mainly sum voltage drop in cathode drop (V_C), plasma (V_p) and anode drop regions (V_a) apart from of work function related factor and I is welding current. Product of welding current (I) and voltage drop in particular region governs the heat generated in that zone e.g. near anode, cathode and in plasma region. In case of DCEN polarity, high heat generation at work piece facilitates melting of base metal to develop a weld joint of thick plates.

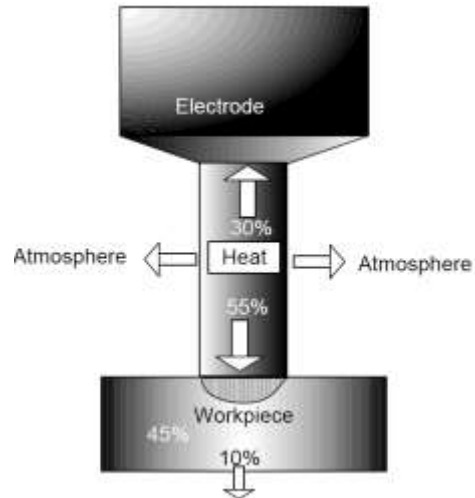


Fig. 41 Distribution of heat from the welding arc in DCEN polarity

Rationale behind variation in arc efficiency of different arc welding processes

Under simplified conditions (with DCEN polarity), ratio of the heat generated at anode and total heat generated in the arc is defined as arc efficiency. However, this ratio indicates the arc efficiency only in case of non-consumable arc welding processes such as GTAW, PAW, Laser and electron beam welding processes where filler metal is not commonly used. However, this definition doesn't reflect true arc efficiency for consumable arc welding processes as it doesn't include use of heat generated in plasma region and cathode side for melting of electrode or filler metal and base metal (Fig. 8.2). Therefore, arc efficiency equation for consumable arc welding processes must include heat used for melting of both work piece and electrode. Since consumable arc welding processes (SMAW, SAW, GMAW) use heat generated both at cathode and anode for melting of filler and base metal while in case of non-consumable arc welding processes (GTAW, PAW) heat generated at the anode only is used for melting of the base metal, therefore, in general, consumable arc welding processes offer higher arc efficiency than non-consumable arc welding processes. Additionally, in case of consumable arc welding processes (SMAW, SAW) heat generated is more effectively used because of reduced heat losses to surrounding as weld pool is covered by molten flux and slag. Welding processes in ascending order of arc efficiency are GTA, GMA, SMA, and SAW. GTAW offer's lower arc efficiency (21-48%) than SMAW/GMAW (66-85%) and SA welding (90-99%)

Determination of arc efficiency

Heat generated at the anode is found from sum of heat generated due to electron emission and that from anode drop zone.

$$q_a = [\phi + V_a] I \dots\dots\dots(\text{equation 8.1})$$

where q_a = is the heat at anode

$$\phi \text{ is work function of base metal at temperature } T = [(\phi_0 + 1.5 kT) \dots\dots\dots(\text{equation 8.2})$$

ϕ_0 is work function of base metal at temperature OK

k is the Boltzmann constant

T temperature in Kelvin

V_a anode voltage drop

I welding current

$$\text{Heat generated in plasma region } q_p = V_p I \dots\dots\dots(\text{equation 8.3})$$

Say it's a fraction m % of the heat generated in plasma region goes to anode/work piece for melting = m ($V_p I$) \dots\dots\dots(\text{equation 8.4})

$$\text{So arc efficiency} = \text{total heat used} / \text{total heat generated in arc} = [q_a + m (V_p I)] / VI \dots\dots\dots(\text{equation 8.5})$$

Where V is arc voltage = $V_a + V_p + V_c$

Another way is that $\{[\text{total heat generated in arc} - (\text{heat with plasma region} + \text{heat of cathode drop zone})] / \text{total heat generated in arc}\}$

$$\text{So arc efficiency} = \{[VI - (q_c + (1-m) (V_p I))] / VI\} \text{ or } \{[VI - |V_c| + (1-m) (V_p I)] / VI\} \dots\dots\dots(\text{equation 8.6})$$

Where q_c is the heat generated in cathode drop zone.

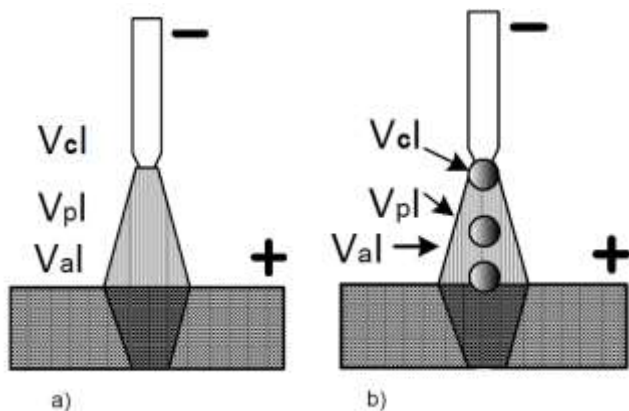


Fig. 42 Schematic of heat generation in different zones of the arc of a) non consumable arc and b) consumable arc welding processes.

8.5 Metal Transfer

Metal transfer refers to the transfer of molten metal from the tip of a consumable electrode to the weld pool and is of great academic and practical importance for consumable electrode welding processes as it directly affects the control over the handling of molten metal, slag and spattering. However, metal transfer is considered to be more of academic importance for GMA and SA welding than practical need. Shielding gas, composition of the electrode, diameter and extension of the electrodes are some of the arc welding related parameters, which affect the mode of metal transfer for a given power setting namely welding current and voltage. Four common modes of metal transfer are generally observed in case of consumable arc welding processes. These have been described in the following sections.

Short Circuit Transfer

This kind of metal transfer takes place, when welding current is very low but high enough to have stable arc and arc gap is small. Under these welding conditions, molten metal droplet grows slowly at the tip of the electrode and then as soon as drop touches weld pool, short-circuiting takes place. Due to narrow arc gap, molten drop does not attain a size big enough to fall down on its own (by weight) under gravitational force. On occurrence of short circuit, welding current flowing through the droplet to the weld pool increases abruptly which in turn results in excessive heat generation that makes the molten metal of droplet thinner (low surface tension). Touching of the molten metal drop to weld pool leads to transfer of molten metal into weld pool by surface tension effect. Once molten metal is transferred to the weld pool, an arc gap is established which in turn increases arc voltage abruptly. This increase in arc voltage (due to setting up of the arc-gap) re-ignites arc and flow of current starts. This whole process is repeated at a rate varying from 20 to more than 200 times per second during the welding. Schematically variation in welding current and arc voltage for short circuit metal transfer is shown in Fig. 43 (a).

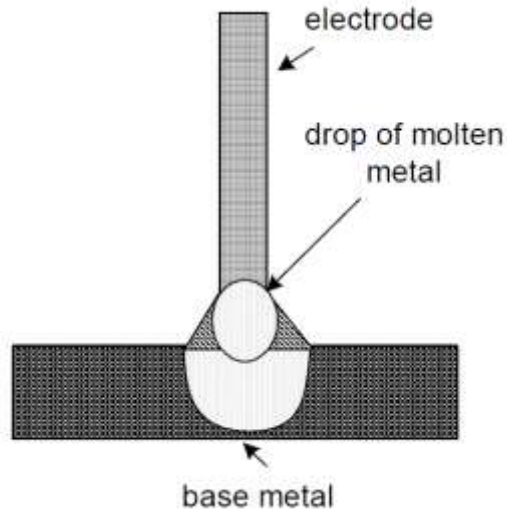


Fig. 43 (a) Schematic of short circuiting metal transfer

Globular Transfer

Globular metal transfer takes place when welding current is low (but higher than that for short circuit transfer) and arc gap is large enough so molten metal droplet can grow slowly (at the tip of the electrode) with melting of the electrode tip (Fig. 43 b). Drop continues to grow until gravitational force on drop (due to its own weight) exceeds the surface tension force other forces if any trying to add the drop at the tip of electrode. As soon as drop attains large size enough and so gravitational force becomes more than other drop-holding-forces such as surface tension force, drop detaches from the electrode tip and is transferred to the weld pool. The transfer of molten metal drop normally occurs when it attains size larger than the electrode diameter. No short-circuit takes place in this mode of metal transfer.

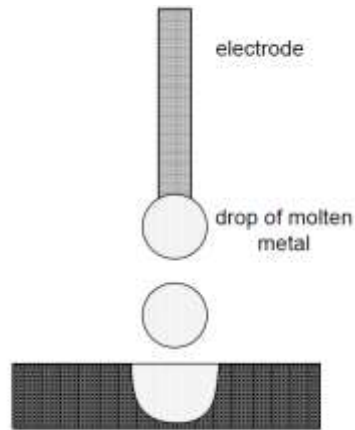


Fig. 43 (b) Schematic of globular metal transfer

Spray Transfer

This kind of metal transfer takes place when welding current density is higher than that is required for globular transfer. High welding current density results in high melting rate and greater pinch force as both melting rate and pinch force are directly related with welding current and are found proportional to square of welding current. Therefore, at high welding current density, droplets are formed rapidly and pinched off from the tip of electrode quickly by high pinch force even when they are of very small in size. Another reason for detachment of small droplets is that high welding current increases temperature of arc zone which in turn lowers the surface tension force. Reduction in surface tension force decreases the resistance to detachment of which in turn facilitates detachment of drops even when they are of small size enough drop from the electrode tip. The transfer of molten metal from electrode tip appears similar to that of spray in line of axis of the electrode (Fig. 43 c). This feature helps to direct the molten metal in proper place where it is required especially in difficult to access areas.

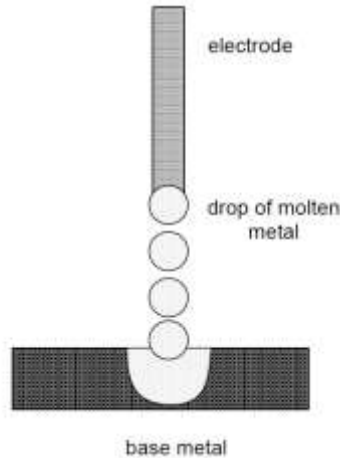


Fig. 43 (c) Schematic of spay metal transfer

Dip Transfer

Dip type of metal transfer is observed when welding current is very low and feed rate is high. Under these welding conditions, electrode is short-circuited with weld pool, which leads to the melting of electrode and transfer of molten drop (Fig. 43 d). Approach wise dip transfer is similar to that of short circuit metal transfer and many times two are used interchangeably. However, these two differ in respect of welding conditions especially arc gap that lead to these two types of metal transfers. Low welding current and narrow arc gap (at normal feed rate) results in short circuit mode of metal transfer while the dip transfer is primarily caused by abnormally high feed rate even when working with recommended range of welding current and arc gap.

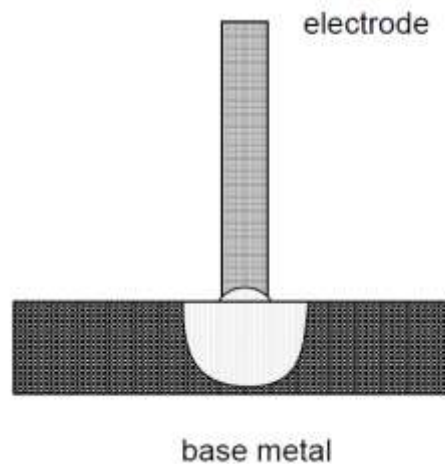


Fig. 43 (d) Schematic of dip transfer

8.6 Melting Rate

In consumable arc welding processes, weld metal deposition rate is governed by the rate at which electrode is melted during welding. Melting of the electrode needs the sensible and latent heat, which is supplied by arc through the electrical reactions i.e. heat generated at anode ($I.V_a$), cathode ($I.V_c$) and plasma zone ($I.V_p$). In case of DCEN polarity, heat generated in anode drop region and plasma region do not influence melting of electrode tip appreciably as electrode (cathode) in case of straight polarity (DCEN) gets very negligible heat from these two regions (anode and plasma). Hence, in case of straight polarity (DCEN), melting rate of electrode primarily depends on the heat generated by a) cathode reaction and b) electrical resistance heating. Accordingly, melting rate of electrode for consumable arc welding processes is given by following equation:

$$\text{Melting Rate} = a \times I + b \times L \times I^2 \dots\dots\dots(\text{equation 8.7})$$

Where a & b are constant {(independent of electrode extension (L) and welding current (I)}

Value of constant "a" depends on ionization potential of electrode material (ability to emit the charge carriers), polarity, composition of electrode and anode/cathode voltage drops while another constant "b" accounts for electrical resistance of electrode (which in turn depends on electrode diameters and resistivity of electrode metal).

Melting rate equation suggests that first factor ($a \times I$) accounts for electrode melting due to heat generated by anode/cathode reaction and second factor ($b \times L \times I^2$) considers the melting rate owing to heat generated by electrical resistance heating. Melting rate is mainly governed by the first factor when welding current is low, electrode diameter is large and extension is small, whereas second factor significantly determines the melting rate of electrode when welding current in high, electrode diameter is small, extension is large and electrical resistivity of electrode metal is high.

Factors Limiting the Melting Rate

Difference in values of constant a and b and welding parameters lead to the variation in melting rate of the electrode in case of different welding processes. To increase the melting rate, welding current for a specific welding process can be increased up to a limit. The upper limit of welding current is influenced by two factors a) extent overheating of electrode caused by electrical resistance heating and so related thermal degradation of the electrode and b) required mode of metal transfer for smooth deposition of weld metal with minimum spatter. For example, in semiautomatic welding process such MIG/SAW, minimum welding current is determined by the current level at which short circuit metal transfer starts and upper level of current is limited by appearance of rotational spray transfer. For a given electrode material and diameter, upper limit of current in case of SMAW is dictated by thermal composition of the electrode coating and that in case of GTAW is determined by thermal damage to tungsten electrode. Lower level of current in general determined is by arc stability (the current at which stable arc is developed) besides other minimum requirement of weld such as penetration, proper placement of the weld metal and control over the weld pool especially in vertical and overhead welding positions and those related with poor accessibility. Depending upon these factors higher and lower limits of welding current melting rate are decided.

Example

A TIG welding process uses DCEN polarity, arc voltage of 30 V and welding current of 120 A for welding of 2 mm thin plate. Assuming a) the voltage drop in anode, cathode and plasma regions is 16 V, 10 V, 4 V respectively and b) 20 % of heat generated in plasma zone is used for melting of base metal and c) all heat generated in anode drop zone is used for welding. Neglecting the voltage drop on account of work function of metal during welding, calculate the arc efficiency.

Solution

Arc efficiency: $(\text{Heat generated in anode drop zone} + \text{heat generated in plasma used welding}) / \text{all heat produced by welding arc}$

$: V_a \times I + m(V_p \times I)/V \sim (V_a + mV_p)/V$

$(16 \times 0.2 \times 4)/30 \sim 16.8/30$

Arc efficiency: 0.56~56%

8.7 Arc Welding Power Source

One of the main requirements of a welding power source is to deliver controllable current at a voltage desired according to the demands of the welding process. Each welding process has distinct features from other processes in the form of process controls required. Therefore, arc welding power sources play very important role in successful welding. The conventional welding power sources are: Power Source Supply (i) Welding Transformer AC (ii) Welding Rectifier DC (iii) Welding Generators AC/DC (IV) Inverter type welding power source DC

Welding transformers, rectifiers and DC generators are used in shops while engine coupled DC and AC generators are used at site where domestic line supply is not available. Rectifiers and transformers are usually preferred because of lower noise, higher efficiency and lower maintenance as compared to generators. The inverter type welding power source first transforms the AC into DC. The DC power is then fed into a step-down transformer to produce the desired welding voltage/current. The pulse of high voltage and high frequency DC is fed to the main step-down transformer and there it is transformed into low voltage and high frequency DC suitable for welding. Finally, low voltage and high frequency DC is passed through filters and for rectification. The switching on and off is performed by solid state switches at frequencies above 10,000. The high switching frequency reduces the volume of the step down transformer. The inverter type of power source provides better features for power control and overload protection. These systems are found more efficient and better in respect of control of welding parameters than other welding system. The invertors with microcontrollers allow changes in electrical characteristics of the welding power by software in real time. This can be done even on a cycle by cycle basis so as to provide features such as pulsing the welding current, variable ratios and current densities, stepped variable frequencies.

Selection of a power source mainly depends on the welding process and welding consumables to be used for arc welding. The open circuit voltage normally ranges between 70-90 V in case of welding transformers while that in case of rectifiers varies from 20-60 V. Moreover, welding arc voltage becomes lower than open circuit voltage of the power source. Welding power sources can be classified based on different parameters related with them as under:

□ Type of current: A.C., D.C. or both. □ Cooling medium: Air, water, oil cooled. □ Cooling system: Forced or natural cooling □ Static characteristics: Constant current, constant voltage, rising characteristics.

Characteristics of power source

Each welding power source has set of characteristics indicating the capability and quality of the power source. These characteristics help in selection of suitable welding power source for a given welding condition. Basic characteristics of a welding power source are given below: □ Open circuit voltage (OCV) □ Power factor (pf)

□ Static characteristics □ Dynamic characteristics □ Current rating and duty cycle □ Class of Insulation

Open circuit voltage (OCV)

OCV shows the potential difference between the two terminals of the power source when there is no load. Setting up of correct open circuit voltage is important for stability of welding arc especially when AC is used. The selection of an optimum value of OCV (50-100V) depends on the type of base metal, composition of electrode coating, type of welding current and polarity, type of welding process etc. Base metal of low ionization potential (indicating ease of emitting free of electrons) needs lower OCV than that of high ionization potential metal. Presence of low ionization potential elements such as K, Na and Ca in electrode coating/flux in optimum amount reduces OCV setting required for welding. AC welding needs higher OCV compared with DC owing to problem of arc stability as in case of AC welding current continuously changes its direction and magnitude while in case DC it remains constant. In the same line, GTAW needs lower OCV than GMAW and other welding processes like SMAW and SAW because GTAW

uses tungsten electrode which has good free electron emitting capability by thermal and field emission mechanism. Abundance of free electron in GTAW under welding conditions lowers the OCV needed for having stable welding arc. Too high OCV may cause electric shock. OCV is generally found to be different from arc voltage. Arc voltage is potential difference between the electrode tip and work piece surface when there is flow of current. Any fluctuation in arc length affects the resistance to flow of current through plasma and hence arc voltage is also affected. Increase in arc length or electrode extension increases the arc voltage. Further, electrical resistance heating of electrode increases with electrode extension for given welding parameters.

Power factor (p_f)

Power factor of a power source is defined as a ratio of actual power (KW) used to produce the rated load (which is registered on the power meter) and apparent power drawn from the supply line (KVA) during welding. It is always desired to have high power factor (p_f). Low power factor indicates unnecessary wastage of power and less efficient utilization of power for welding. Welding transformers usually offer higher power factor than other power sources. However, sometimes low power factor is intentionally used with welding transformers to increase the stability of AC welding arc. Application of a welding power source with high power factor offers many advantages such as: □ Reduction of the reactive power in a system, which in turn reduces the power consumption and so drop in cost of power □ More economic operations at an electrical installation (higher effective power for the same apparent power) □ Improved voltage quality and fewer voltage drops □ Use of low cable cross-section □ Smaller transmission losses

Static Characteristic of power source

Static characteristic of a welding source exhibits the trend of variation in voltage with current when power source is connected to pure resistive load. This variation may be of three types, namely constant current (CC), constant voltage (CV), rising voltage (RV). Constant current power source the volt ampere output curves for constant current power source are called 'drooper' because of substantial downward or negative slope

of the curves. With a change in arc voltage, the variation in welding current is small and, therefore, with a consumable electrode welding process, electrode melting rate remains fairly constant even with a minor change in arc length (Fig. 44). These power sources are required for processes that use relatively thicker consumable electrodes which may sometimes get stuck to workpiece or with non-consumable tungsten electrode where touching of electrode with base metal for starting of arc may lead to damage of electrode if current is unlimited. Under these conditions, the short circuiting current shall be limited which would provide safety to power source and the electrode.

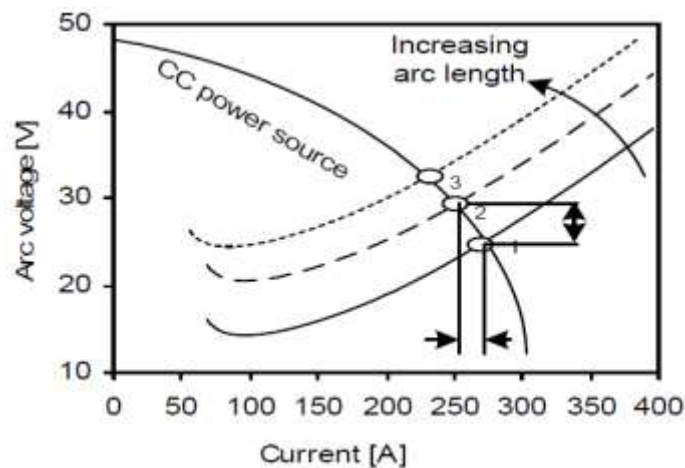


Fig. 44 Static characteristics of constant current welding power source

In constant current power source, variation in welding current with arc voltage (due to fluctuations in arc length) is very small therefore welding current remains more or less constant despite of fluctuations in arc voltage / length. Hence, this type of power source is also found suitable for all those welding processes where large fluctuation in arc length is likely to take place e.g., MMA and TIG welding. Constant voltage power source In CV power sources, a small variation in arc voltage (due to fluctuations in arc length) causes significant change in welding current. Since arc voltage remains almost constant during welding despite of fluctuations in arc length therefore this type of power source is called constant voltage type. Moreover, the constant voltage power sources do not offer true constant voltage output as current- voltage relationship curve shows slightly downward or negative slope. This negative slope is attributed to internal

electrical resistance and inductance in the welding circuit that causes a minor droop in the output volt-ampere characteristics of the power source (Fig. 44). This type of power sources is found more suitable for all those welding processes where fluctuations in arc length during welding is limited like in semiautomatic welding process MIG, SAW.

and PAW. The power source shall supply necessary current to melt the electrode at the rate required to maintain the preset voltage or arc length. The speed of electrode drive is used to control feed rate of the electrode which in turns affects the arc gap/voltage. The variation arc voltage changes the average welding current. The use of such power source in conjunction with a constant speed electrode wire feed drive results in a self regulating or self adjusting arc system. Due to some internal or external fluctuation if the change in arc length occurs, then it regulates the electrode melting rate MR (by regulating current) to regain the desired arc length.

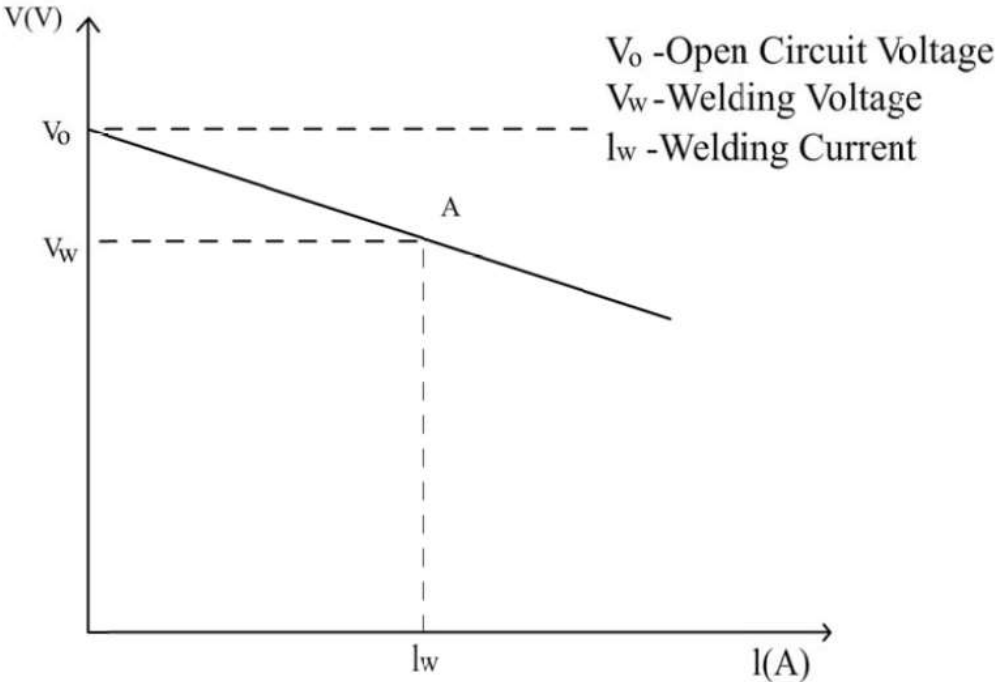


Fig 44: Static characteristics of constant voltage welding power source

Self regulating arc

In semiautomatic welding processes where constant voltage power source is used in association with automatically fed (constant speed) small diameter consumable electrode, arc length is maintained by self-regulating arc. Self-regulating arc is one, which governs the melting/burn off rate of the electrode (by changing the current) so that feed rate becomes equal to melting rate for maintaining the arc length. For example, increase in arc length due to any reason shifts the operating point from 2 to 3 thus increases the arc voltage (Fig. 45). Operating point is the point of intersection of power source characteristics with arc characteristics. Rise in arc voltage decreases the welding current significantly. Decrease in welding current lowers the melting rate (see melting rate equation) of the electrode thus decreases the arc gap if electrode is fed at constant speed. Reverse phenomenon happens if arc length decreases (shifting the operating point from 2 to 1).

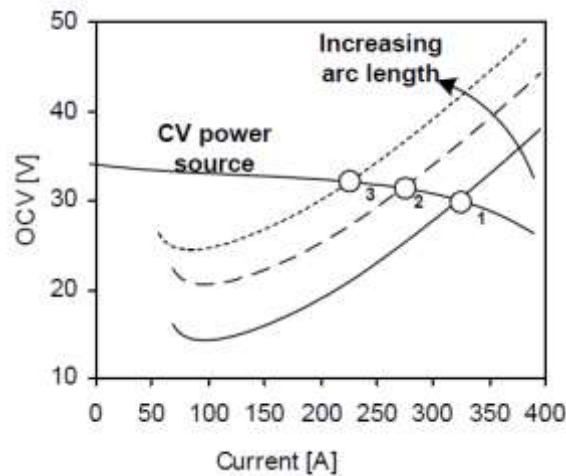


Fig. 45 Static characteristics of constant voltage welding power showing operating points with increasing arc length

Rising Characteristics

Power sources with rising characteristics show increase in arc voltage with increase of welding current (Fig. 45a). In automatic welding processes where strictly constant voltage is required, power sources with rising characteristics are used.

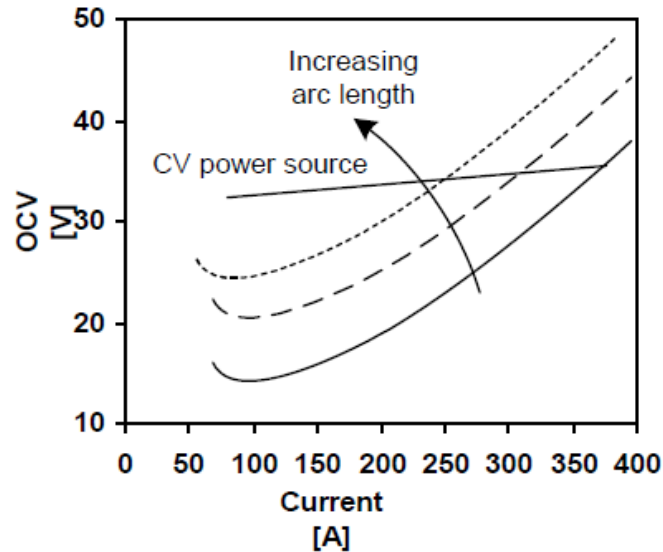


Fig. 45a Static characteristics of rising voltage welding power showing operating points with different arc length

Dynamic characteristic

Welding arc is subjected to severe and rapid fluctuations in arc voltage (due to continuous minor changes in arc length) and welding current (Fig. 46). Number from 1 to 4 in figure 5 indicates different stages of welding arc during welding, suggesting that welding arc is never in a steady state. It causes transients in starting, extinction and re-ignition after each half cycle in A.C. welding. To cope up with these conditions power source should have good dynamic characteristics to obtain stable and smooth arc. Dynamic characteristic of the power source describes the instantaneous variation in arc voltage with change in welding current over an extremely short period of welding. A power source with good dynamic characteristic results in an immediate change in arc voltage and welding current corresponding to the changing welding conditions so as to give smooth and stable arc.

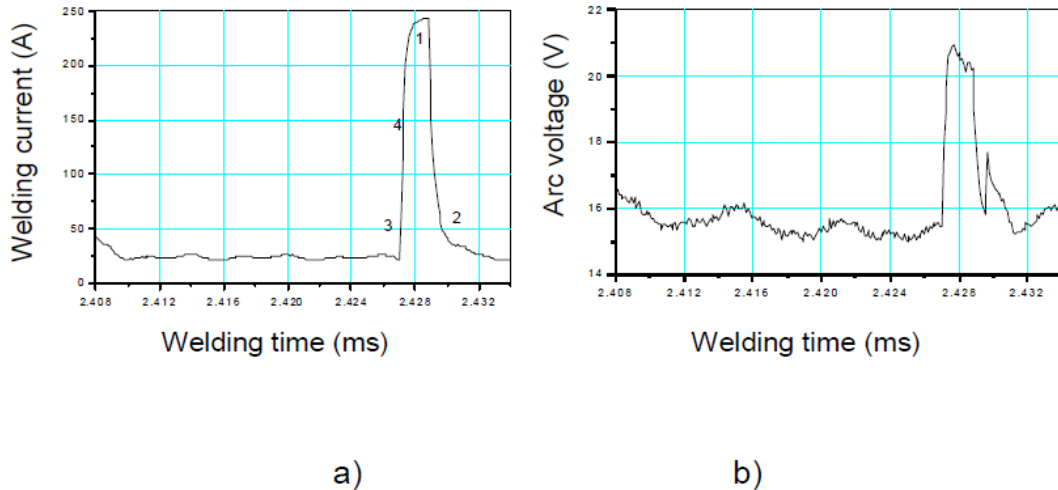


Fig. 46 Dynamic characteristics of a power source showing a) current vs time and b) voltage vs time relationship.

8.8 Duty Cycle

Duty cycle is defined as ratio of arcing time to the weld cycle time multiplied by 100. Welding cycle time is either 5 minutes as per European standards or 10 minutes as per American standard and accordingly power sources are designed. If arcing time is continuous for 5 minutes then as per European standard it is considered as 100% duty cycle and that will be 50% duty cycle as per American standard. At 100% duty cycle, minimum current is drawn from the welding power source. Welding power source operating at low duty cycle allows high welding current for welding purpose safely. The welding current which can be drawn at a duty cycle can be evaluated from the following equation;

$$D_R \times I_R^2 = I_{100}^2 \times D_{100} \dots\dots\dots$$

Where I - Current at 100% duty cycle

D_{100} - 100% duty cycle

I_R - Current at required duty cycle

D_R - Required duty cycle

Example

Current rating for a welding power source is 400 A at 60% duty cycle. Determine the welding current for automatic continuous welding i.e. 100% duty cycle.

Solution:

Rated current: 400 A

Rated duty cycle: 60%

Desired duty cycle: 100%

Desired current ?

Desired duty cycle = $\frac{(\text{rated current})^2 \times \text{rated duty cycle}}{(\text{desired current})^2}$

$$100 = \frac{(400)^2 \times 60}{(\text{desired current})^2}$$

Answer: Desired current: 310A

Importance of duty cycle

During the welding, heavy current is drawn from the power source. Flow of heavy current through the transformer coil and connecting cables causes electrical heating. Continuous heating during welding for long time may damage coils and cables. Therefore, welding operation should be stopped for some time depending upon the level of welding current being drawn from the power source. The total weld cycle is taken as sum of actual welding time and rest time. Duty cycle refers to the percentage of welding time of total welding cycle i.e. welding time divided by welding time plus and rest time. Total welding cycle of 5 minutes is normally taken in India as in European standard. For example, welding for 3 minutes and followed by rest of 2 minutes in total welding cycle of 5 minutes corresponds to 60% duty cycle. Duty cycle and associated welding current are important as it ensures that power source is safe and its windings are not damaged due to increase in temperature due to electrical resistance heating beyond specified limit. Moreover, the maximum current which can be drawn from a power source at given a duty cycle depends upon size of winding wire, type of insulation and cooling system of the power source. In general, large diameter cable wire, high temperature resistant insulation and force cooling system allow high welding current drawn from the welding source at a given duty cycle.

8.9 Class of Insulation

The duty cycle of a power source for a given current setting is primarily governed by the maximum allowable temperature of various components (primary and secondary coils, cables, connectors etc.), which in turn depends on the quality and type of insulation and materials of coils used for manufacturing of power source. The insulation is classified as A, E, B, F & G in increase order of their maximum allowable temperature 60, 75, 80, 100 & 125 °C respectively.

8.10 High Frequency Unit

Some power sources need high frequency unit to start the arc like in TIG and plasma arc welding. High frequency unit is introduced in the welding circuit.

Filters are used between the control circuit and HF unit to avoid damage of control circuit. High frequency unit is a device which supplies pulses of high voltage (of the order of few kV) and low current at high frequency (of few kHz). The high voltage pulse supplied by HF unit ionizes the gaseous medium between electrode and workpiece/nozzle to produce starting pilot arc which ultimately leads to the ignitions of the main arc. Although high voltage can be fatal for operator but at high frequencies current passes through the skin and does not enter the body. This is called skin effect i.e. current passes through the skin without any damage to the operator.

8.11 Feed drives for constant arc length

Two types of feed systems are generally used for maintaining the arc length a) constant speed feed drive and b) variable speed feed drive. In constant speed feed drives, feed rollers rotating at fixed speed are used for pushing/pulling wire to feed into the weld so as to maintain the arc length during welding (Fig. 10.4 a). This type drive is normally used with constant voltage power sources in conjunction with small diameter electrodes where self-regulating arc helps to attain the constancy in arc length. In case of variable speed feed drives, feed rollers used for feeding electrode wire (in consumable arc welding processes like SAW and GMAW) are rotated at varying speed as per need to maintain the arc length during welding. Fluctuation in arc length due to any reason is

compensated by increasing or decreasing the electrode feed rate. The electrode feed rate is controlled by regulating the speed of feed rollers powered by electric motor (Fig. 47). Input power to the variable speed motor is regulated with help of sensor which takes inputs from fluctuations in the arc gap. For example, an increase in arc gap sensed by sensor increases the input power to the variable speed motor to increase the feed rate of electrode so as to maintain arc gap.

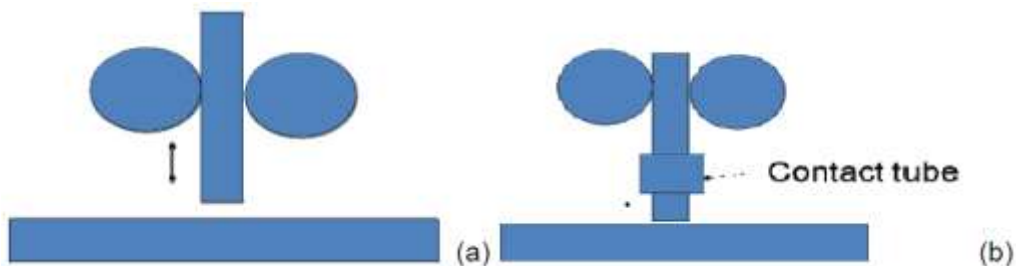


Fig. 47 Schematics diagrams show electrode feed drives for controlling arc length a) variable speed feed drive and b) constant speed feed drive

8.12 Resistance Welding Equipment - Power Supplies

As with weld heads, resistance welding power supplies are available in many varieties to suit requirements based on price, control, and speed. The four basic variants are Alternative Current (AC), Capacitor Discharge (CD), High Frequency Inverter (HF), and Direct Current (DC). Their individual advantages and limitations are discussed below:

- Alternating Current (AC)

As the name implies, this type of power supply sends out energy where the current changes direction every half cycle. The power supplies takes in high-voltage low-current signal from the power lines and converts switches it to a low-voltage high-current signal. In the process, the power supply does some conditioning of the AC pulse by chopping off part of the cycle and counting the number of cycles. These type of power supplies work well where a long weld pulse is required and control does not have to be very precise.

- **Capacitor Discharge (CD)**
In these power supplies, the energy is stored in capacitor banks and delivered through a transformer to the weld head. These units work well for applications requiring short burst of energy such as for conductive materials and projection welds. However, precise control of the weld pulse shape is difficult.
- **Direct Current (DC)**
DC power supplies take in AC energy from the power lines and convert it into DC energy for welding. Energy can be controlled to provide fixed current, voltage, or power. Peak currents are limited for such power supplies to under 6 kA.
- **High Frequency Inverters (DC)**
Inverters are designed to mimic the signal from a DC unit but with the capability of supplying much higher current levels, up to 100 kA. Like DC units, HF inverters can be operated in current, voltage, and power mode. Some of the newer units also offer a combo mode. These units have become the workhorses in applications requiring precise control and speed (rate of welding). However, they are more expensive than AC welders at similar energy levels.

9. Advancements in pulse gas metal arc welding

Gas metal arc welding (GMAW) is widely used in industries for welding wide variety of ferrous and non-ferrous materials. GMAW achieves coalescence of metals by melting continuously fed current-carrying wire. However, attractive looking GMAW needs consistent, high-quality welding procedures to achieve good quality. This need is due to continuous control metal transfer that is necessary in GMAW. At relatively low currents, GMAW operates in the globular metal transfer mode. When current is increased, the process transits to spray mode. Globular mode is characterized by periodic formation of big droplets at the end of electrodes (which detach due to gravitational force in to the weld pool) and suffers from lack of control over molten droplets and arc instability due to formation of big droplets. Spray mode offers high deposition rate but minimum current

for spray mode is too high for some materials, large heat input to workpiece, wide bead, and only downhand positional capability are some of its drawbacks.

During the mid-1960s, an alternative transfer technique of GMAW-P was invented. This mode of metal transfer overcomes the drawbacks of globular mode while achieving the benefits of spray transfer. This mode is characterized by pulsing of current between low-level background current and high-level peak current in such a way that mean current is always below the threshold level of spray transfer. The purpose of background current is to maintain arc whereas peak currents are long enough to make sure detachment of the molten droplet. Due to existence of number of metal transfer modes, the knowledge of the transition current zone between the globular and spray mode has great importance in the GMAW process, because it determines the working conditions of the process. This region of operation for pulse is very narrow and is dependent upon number of changing welding conditions during welding operation. Hence good process stability and quality of weld fillet can only be obtained by controlling the mode of metal transfer. With the advent of electronics, significant progress has been made in the development of high-performance arc welding equipment.

9.1 *Advancement in power source design*

The basic function of a welding power source is to produce and control current and voltage required for arc welding. Market demands for reduction in size, cost, weight and improved reliability has seen many changes in the design of power sources. These advancements in the design have been possible because of advances in electronics industry and better understanding of welding arc phenomena.

Conventional transistorised power sources

Conventional transistorised power sources were in-phase regulator type utilising paralleled connected banks of small power transistors, which serves as variable load resistor. Welding machines of this design are simple and robust in nature. The drawbacks of this design are high cost, large size due to water-cooling units and lacks advanced control feature needed for GMAW-P.

Secondary transistor-controlled series regulators

The secondary transistor-controlled series regulators operate in two modes through secondary transistor: periodic on and off at a switching frequency or by adjusting the ratio of the make-time to the break-time (pulse width modulation). Higher output is attained by large switching frequency or by higher ratio of make-time to the break-time. Benefits from machines of this design is reduced power dissipation, air cooled comparatively smaller size, smooth output and are well suited for the pulsed GMAW due to improved response rate and better control. Popular variations like chopper control power sources are available, yet they are still inefficient, available in restricted ranges of control and operation, bulky and expensive to manufacture.

Primary transistor switched inverter technology

Primary transistor switched inverter technology transform input signal to high operating frequency using high-speed transistor switches. Operations at high frequency give direct benefits in the form of portability, lesser weight, arc stability, faster response times, energy efficient and reduced running cost. Indirect benefits are in form of reduction in labour and transportation cost. A brief comparison between inverters and other forms of power source design is tabulate in [Table 1](#).

Table 1
Comparison of various power source designs

Power sources	Traditional	Inverter
Power consumed	More	Less
Electrical efficiency	Poor	Good
Size	Large	Compact
Weight	More	Less
Areas of usage	Research only	Wide range
Frequency of operation	Low	High
Running cost	High	Low
Cost of production	High	Low
Labour cost	High	Low
Material cost	High	Low
Number of tapings in transformer	More	None
Design	Simpler	Complex
Repair	Possible	Replace mostly
Control of metal transfer mode	Poor	Better
Arc stability	Low	High

9.2 Advancement in pulse waveform

Principal factors and influences

GMAW-P offers significant benefits. However, in order to achieve these advantages, careful setting of large number of welding parameters is required. Complete explanation of influence of individual parameters is beyond the scope of this paper.

Pulse waveforms

Waveforms are response of welding power source to actions of electric arc. The area under the waveform determines the amount of energy transmitted by a single droplet to the workpiece. Waveform allows heat transfer to workpiece in a more effective manner and has the ability to manipulate travel speeds, heat input, fumes, spatter and appearance of weld.

In order to improve control of metal transfer, waveforms can now be tailor made to suit different welding conditions as the power sources respond to changes demanded by the software instantaneously. New way of achieving better penetration is through use of two distinct series of welding pulses and pulsing wire-feed rate. Two of the pulse waveforms employing this technique have been shown in [Fig. 48](#).

In Alu-Plus, combinations of hot and cold series of pulses at a fixed frequency are employed. Set of cold pulses maintains the arc length, preheats both the electrode wire and the material surface, stabilises weld pool and produces a weld ripple each time it is fired. Set of hot pulses improves control over weld pool and penetration. Pulsing of wire-feed rate produces acceleration and deceleration phases resulting in ripples on weld bead. During acceleration phase, arc energy grows and achieves better weld penetration. In deceleration phase, arc energy reduces and stabilizes weld pool.

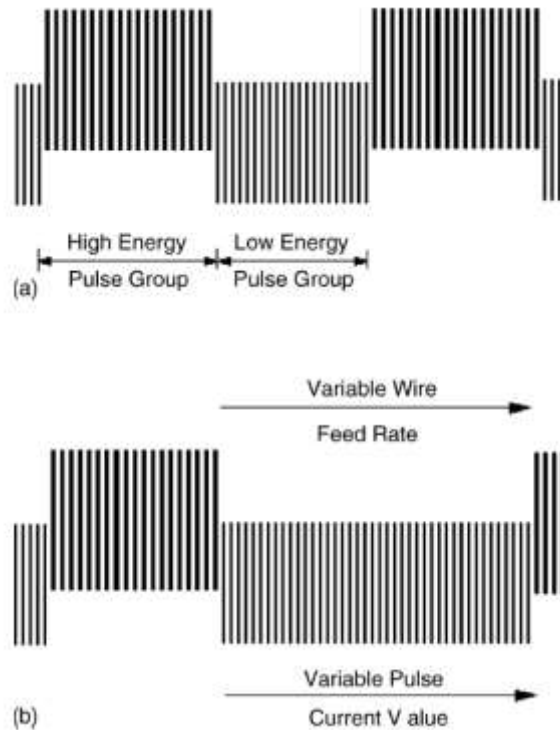


Fig. 48 Different pulse waveforms for GMAW-P: (a) Alu-Plus and (b) Double Pulse

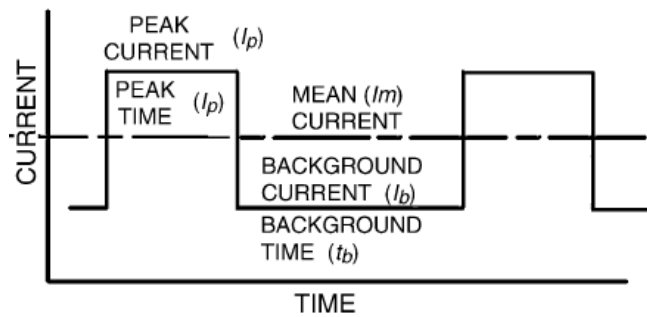


Fig. 48c Perfectly rectangular signal

9.3 Advancement in control features

With increasing use of automation in welding systems, need for automatic control system for achieving better quality and improved control has grown. In a welding system, principal sources of disturbances, which need constant control and adjustments, are welding parameters. For achieving controlled transfer during pulse welding, it is essential that wire-feed rate is balanced by burn rate. This means achieving one drop per pulse condition all the time, which involves constant control of all

the pulse parameters. Synergic control is defined as – ‘any system (open or closed loop) by which a significant pulse parameter (or the corresponding wire-feed speed) is amended such that an equilibrium condition is maintained over a range of wirefeed speeds (or average current levels)’. Synergic has been practically implemented into modern welding machine in two forms: one-knob control and microcomputer control.

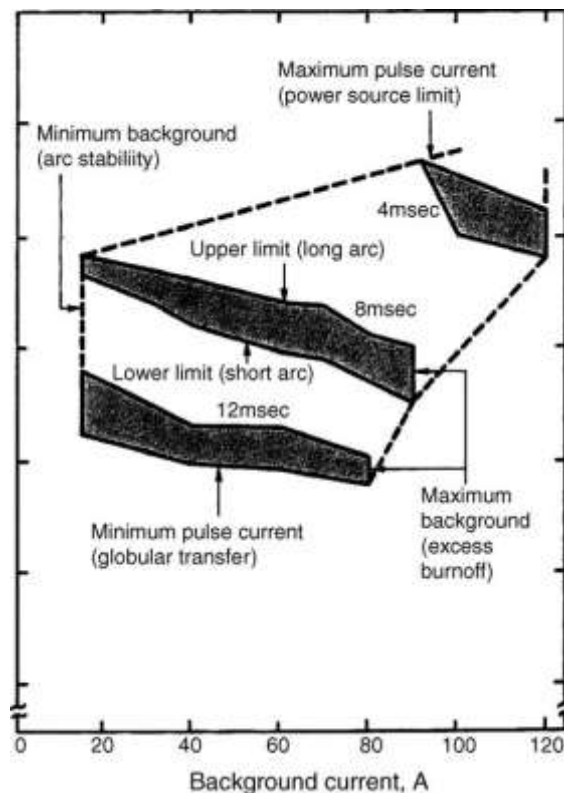


Fig. 49 Pulse parametric zone

One-knob control

One-knob control achieves manipulation of all pulse variables by using a single control or knob. This type of control eases the jobs of welder, allowing him to manipulate all welding parameters over wide range of wire-feed rate and current. This system uses tacho generator reading as input to hardwired electrical unit, which generates appropriate square waveform based on input. Logic of one-knob control is implemented in two ways.

Synergic control

This mode can also be regarded as wire-feed speed control of mean current [12]. Power supply and wire-feeder are directly linked in such a way that means current is determined by wire-feed rate to ensure stable arc. The pulse waveform (see Fig. 48a) produced by this type of control has constant peak duration and excess current. Variable pulse parameters are peak current, base current and base current duration. This control can only be operated in the fixed ranges of mean current as large mean current might produce multiple droplets detachments per pulse.

Self-regulating control

This mode can also be regarded as voltage control of mean current or error voltage system. The welding voltage varies according to the arc length in GMAW. This system always tries to restore arc length to set reference voltage by automatically modifying the burn off rate.

One-knob control

One-knob control achieves manipulation of all pulse variables by using a single control or knob. This type of control eases the jobs of welder, allowing him to manipulate all welding parameters over wide range of wire-feed rate and current. This system uses tacho generator reading as input to hardwired electrical unit, which generates appropriate square waveform based on input. Logic of one-knob control is implemented in two ways.

Synergic control

This mode can also be regarded as wire-feed speed control of mean current. Power supply and wire-feeder are directly linked in such a way that means current is determined by wire-feed rate to ensure stable arc. The circuit arrangement for this system is shown in Fig. 50.

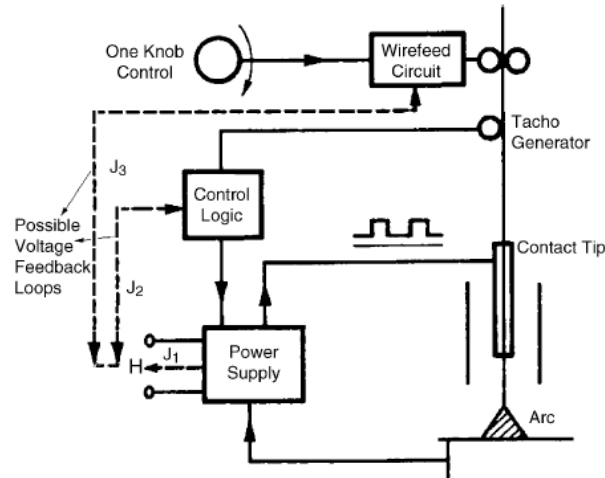


Fig. 50 Synergic control

The pulse waveform (see Fig. 48a) produced by this type of control has constant peak duration and excess current. Variable pulse parameters are peak current, base current and base current duration. This control can only be operated in the fixed ranges of mean current as large mean current might produce multiple droplets detachments per pulse.

Self-regulating control

This mode can also be regarded as voltage control of mean current or error voltage system. The welding voltage varies according to the arc length in GMAW. This system always tries to restore arc length to set reference voltage by automatically modifying the burn off rate. The circuit arrangement for this system is shown in Fig. 51.

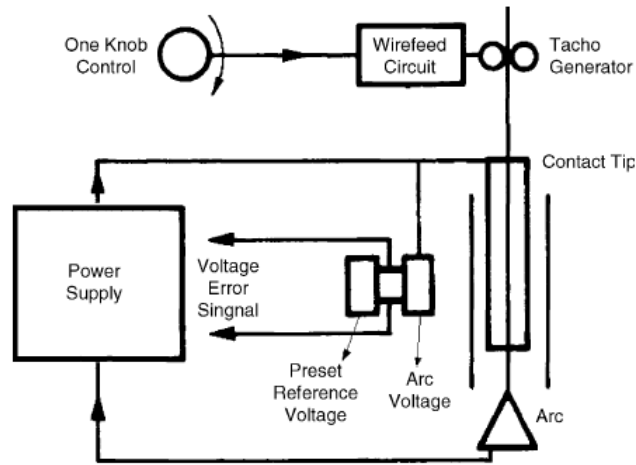


Fig. 51 Self-regulating control

The pulse waveform produced by this type of control has constant peak duration, peak current and base current. Only variable pulse parameter is base current duration. This control logic is poorly defined as base current influences droplet size and requires constant adjustment to electrical stick out (or arc length).

One-knob control also suffers from need for calibration at the start that requires considerable operator skills, cannot incorporate other system variables such as shielding flow gas rate control, seam tracking, etc., and simpler design gives poor flexibility as it restricts search.

Microcomputer control

Latest generation of advanced electronic power sources are controlled by microprocessor or microcontroller. They have replaced traditional hard-wired systems for controlling, sequencing and timing of operations to achieve optimum output. The microprocessors increase flexibility by quick retrieval of predetermined process parameters and storing algorithms, which can compute relationship between various pulsing parameters. Synergic relationships between pulse parameters can be stored in some form of memory system, e.g., EPROM, EEPROM (electrical erasable programmable read only memory) or FLASH ROM, etc. Microcomputer control for synergic systems first takes wire material and diameter as input to compute molten

metal droplet volume. Based on droplet volume, pulsing parameters, wire-feed rate and arc length are automatically selected from memory. The possible disturbances in the system can be extinguishment of arc and change in wire-feed rate or arc length. Former is overcome by initiating the arc again by supplying a high level DC current. Latter is automatically corrected by resetting freshly calculated values of pulsing parameters from synergic relationships defined in the memory. Various types of controls developed with help of digital technology by using microprocessor are as follows.

Arc length regulation control

Arc regulation in modern welding power source is achieved through control of arc voltage. Any change in arc length will possibly result in longer arc length or short-circuiting, which can be detected by monitoring arc voltage. Voltage drop below predetermined threshold arc voltage causes short circuit to occur. To clear short circuit, short pulse of high current is applied. Pulse then returns to its normal form. Wire-feed arc voltage control achieves the control by modifying wire-feed rate. If arc length is increased, wire-feed rate is increased to maintain constant arc length. This method is currently not popular due to poor stability and comparatively slower response rate of wire-feeders. Frequency arc voltage control achieves the control by modifying pulse frequency, which in turn modifies mean current. This mode basically restores the arc length by decreasing the number of drops transferred to the workpiece. CC/CV arc voltage control depends upon dynamic characteristics of the welding power source. CV mode is characterized by large change in current for small voltage change.

10. Chemical Reaction in Welds

Welding process and cleanliness of the weld

In fusion welding, the application of heat of the arc or flame results in the melting of the faying surfaces of the plates to be welded. At high temperature metals become very reactive to atmospheric gases such as nitrogen, hydrogen and oxygen present in and around the arc environment. These gases either get dissolved in weld pool or form their compound. In both the cases, gases adversely affect the soundness of the weld joint and mechanical performance. Therefore, various approaches are used to protect the

weld pool from the atmospheric gases such as developing envelop of inactive (GMAW, SMAW) or inert gases (TIGW, MIGW) around arc and weld pool, welding in vacuum (EBW), covering the pool with molten flux and slag (SAW, ESW). The effectiveness of each method for weld pool protection is different. That is why adverse effect of atmospheric gases in weld produced by different arc welding processes is different (Fig. 52).

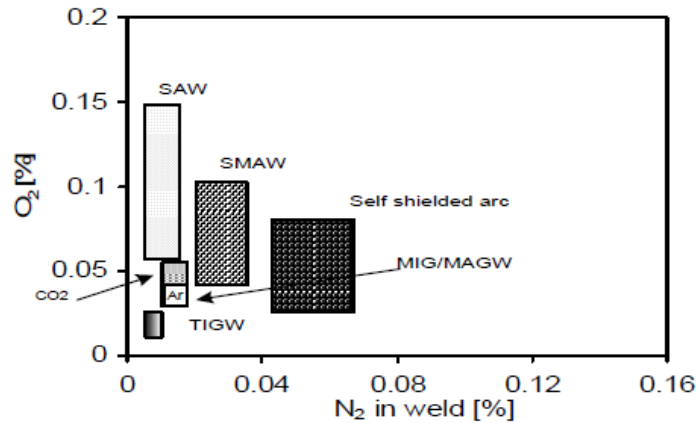


Fig. 52 Schematic diagram showing nitrogen and oxygen content in different welding processes

Amongst the most commonly used arc welding processes, the cleanest weld (having minimum nitrogen and oxygen) is produced by gas tungsten arc welding (GTAW) process due to two important factors associated with GTAW: a) short arc length and b) very stable arc produced by using non-consumable tungsten electrode. A combination of short and stable arc with none-consumable tungsten electrode results a firm shielding of arc and protection of the weld pool by inert gases restricts the entry of atmospheric gases in the arc zone. Gas metal arc welding (GMAW) also offers clean weld but not as clean as produced by GTAW because in case of GMAW arc length is somewhat greater and arc stability is poorer than GTAW. Submerged arc weld (SAW) joints are usually high in oxygen and less in nitrogen because SAW uses flux containing mostly metallic oxides. These oxides decompose and release oxygen in arc zone. The self-shielded fluxed cored metal arc welding processes use electrodes having fluxes in core act as de-oxidizer and slag formers to protect the weld pool. However, weld produced by the

self-shielded fluxed arc welding processes are not as clean as those produced with GMAW.

Effect of atmospheric gases on weld joint

The gases present in weld zone (atmospheric or dissolved in liquid metal) affect the soundness of weld joint. Gases such as oxygen, hydrogen, nitrogen etc. are commonly present in and around the liquid metal. Both oxygen and hydrogen are very important in welding of ferrous and non-ferrous metals; these are mostly produced by decomposition of water vapours (H_2O) in high arc temperature. Oxygen reacts with carbon in case of steel to form CO or CO_2 . These gases should escape out during the solidification; due to high solidification rate encountered in welding processes these gases may not come up to the surface of molten metal and may get trapped. This causes gaseous defects in the weldment, like porosity, blowhole etc. Chances for these defects further increases if the difference in solubility of these gases in liquid and solid state is high. Oxygen reacts with aluminium and form refractory alumina which forms inclusions and reduces the weldability. It's formation can be reduced by proper shielding of arc zone either by inert or inactive gases. Only source of nitrogen is atmosphere and it may form nitrides but it creates fewer problems. Hydrogen is a main problem creator in welding of steel and aluminium alloy due to high difference in liquid and solid state solubility. In case of steel, besides the porosity and blow holes hydrogen causes the problem of cold cracking even if it is present in very small amount, whereas in case of aluminium hydrogen causes pin hole porosity.

Oxides and nitrides formed by these gases if not removed from the weld, act as site of weak zone in form of inclusions which in turn lower the mechanical performance of the weld joint e.g. iron reacts with nitrogen to form hard and brittle needle shape iron nitride (Fe_4N) as shown in Fig. 52. These needle shape micro-constituents offer high stress concentration at the tip of particle matrix interface which under external tensile stresses facilitate the easy nucleation and propagation of crack, therefore fracture occurs at limited elongation (ductility). Similar logic can be given for reduction in mechanical performance of weld joints having high oxygen/oxide content. However, the presence of

N₂ in weld metal is known to increase the tensile strength due to the formation of hardness and brittle iron nitride needles.

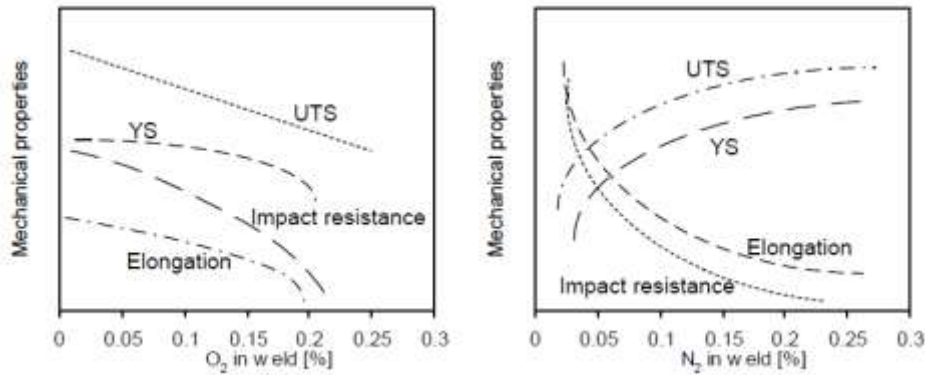


Fig. 52 Influence of oxygen and nitrogen as impurities on mechanical properties of steel weld joints

Additionally, these inclusions formed by oxygen, nitrogen and hydrogen break the discontinuity of metal matrix which in turn decreases the effective load resisting cross section area. Reduction in load resisting cross sectional area lowers the load carrying capacity of the welds. Nitrogen is also a austenite stabilizer which in case of austenitic stainless steel (ASS) welding can place crucial role. Chemical composition of ASS is designed to have about 5-8% ferrite in austenite matrix to control solidification cracking of weld. Presence of nitrogen in weld metal either from atmosphere or with shielding gas (Ar) stabilizes the austenite (so increases the austenite content) and reduces ferrite content in weld which in turn increases the solidification cracking tendency because ferrite in these steels acts as sink for impurities like P and S which otherwise increase cracking tendency of weld.

Effect on weld compositions

Presence of oxygen in arc environment not only increases chances of oxide inclusion formation tendency but also affects the element transfer efficiency from filler/electrode to weld pool due to oxidation of alloying elements (Fig. 53). Sometime composition of the weld is adjusted to get desired combination of mechanical, metallurgical and chemical properties by selecting electrode of suitable composition. Melting of electrode

and coating and then transfer of the= elements from the electrode across the arc zone causes the oxidation of some of the highly reactive elements which may be removed in form of slag. Thus transfer of especially reactive elements to weld pool is reduced which in turn affects the weld metal composition and so mechanical and other performance characteristics of weld.

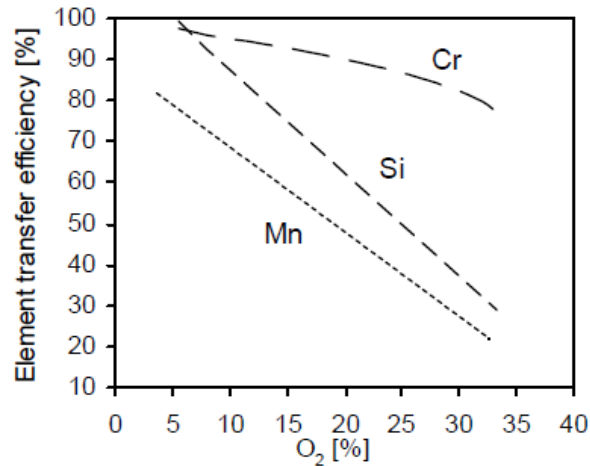


Fig. 53 Influence of oxygen concentration on element transfer efficiency of common elements

Effect of hydrogen on steel and aluminium weld joints Hydrogen

Hydrogen in weld joints of steel and aluminium is considered to be very harmful as it increases the cold cracking tendency in hardenable steel and porosity in aluminium welds. Hydrogen induced porosity in aluminium welds is formed mainly due to high difference in solubility of hydrogen in liquid and solid state. The hydrogen rejected by weld metal on solidification if doesn't get enough time for escaping then it is entrapped in weld and results in hydrogen induced fine porosity. Welds made using different processes produce varying hydrogen concentration owing to difference in solidification time, moisture associated with consumable and protection of the weld pool from atmospheric gases, use of different consumables (Fig. 54). Hydrogen in steel and aluminium weld joint is found mainly due to high difference in solubility of hydrogen in liquid and solid state (Fig. 54).

Cold cracking is caused by hydrogen especially when hard and brittle martensitic structure is formed in the weld and HAZ of hardenable steel. Many theories have been

advanced to explain the cold cracking due to hydrogen. Accordingly to one of hypothesis, hydrogen diffuses towards the vacancies, grain boundary area and other crystallographic imperfections. At these locations, segregation of the hydrogen results in first transformation of atomic hydrogen into gaseous molecules and then builds up the pressure until it is high enough to cause growth of void by propagation of cracks in one of directions having high stress concentration as shown in Fig. 54. Thereafter, process of building up of the pressure and growth of crack is repeated until complete fracture of the weld without any external load occurs. Existence of external or residual tensile stresses further accelerate the crack growth rate and so lower the time required for failure to occur by cold cracking. Presence of both of above discontinuities (cracks and porosity) in the weld decreases mechanical performance of weld joint. Hydrogen in arc zone can come from variety of sources namely:

- Moisture (H₂O) in coating of electrode or on the surface of base metal,
- Hydrocarbons present on the faying surface of base metal in the form of lubricants paints etc
- Inert gas (Ar) mixed with hydrogen to increase the heat input
- Hydrogen in dissolved state in metal (beyond limits) being welded such as aluminium and steel

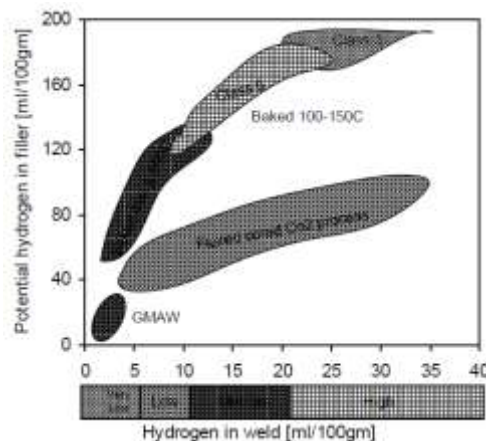


Fig. 54 hydrogen content in weld developed using different welding processes

It has been reported that proper baking of electrodes directly reduces the cold cracking tendency and time for failure delayed cracking. Therefore, attempt should be made to avoid the hydrogen from above sources by taking suitable corrective action.

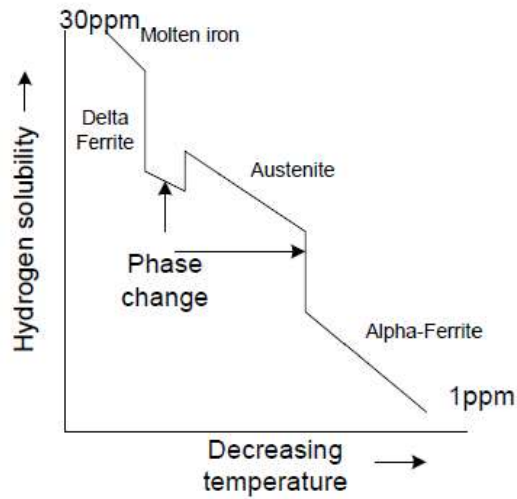


Fig. 55

Schematic of hydrogen solubility as a function of temperature of iron



Hydrogen induced crack

Fig.56

11. Flux in welding

Fluxes are commonly used to take care of problems related with oxygen and nitrogen. Variety of fluxes is used to improve the quality of the weld. These fluxes are grouped in three categories namely halide fluxes (mainly composed of chlorides and fluorides of Na, K, Ba, Mg) and oxide fluxes (oxides of Ca, Mn, Fe, Ti, Si) and mixture of halide and oxide fluxes. Halide fluxes are free from oxides and therefore these are mainly used for welding highly reactive metals having good affinity with oxygen such as Ti, Mg and Al alloys while oxide fluxes are used for welding of low strength and non-critical welds joints of steel. In general, calcium fluoride in flux reduces hydrogen concentration in weld (Fig. 36.4). Halide-oxide type fluxes are used for semi-critical application in welding of high strength steels.

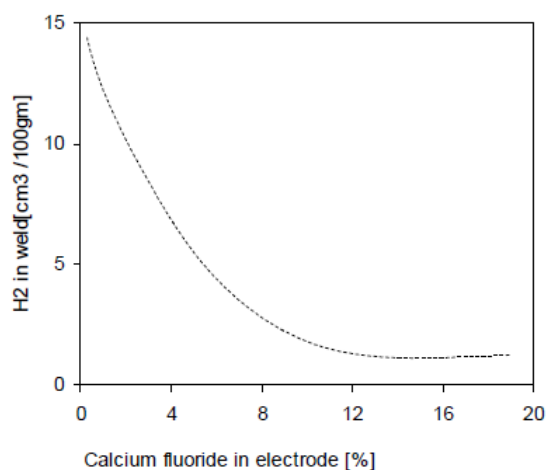


Fig. 57 Influence of calcium fluoride on hydrogen concentration in weld joints

Basicity of the flux

The composition of fluxes is adjusted so as to get proper basicity index as it affects the ability of flux to remove impurities like sulphur and oxygen from melt. The basicity index of the flux refers to ratio of sum of amount of all basic oxides and that of non-basic oxides. Basic oxides (CaO is most common) are donors of the oxygen while acidic oxides (such as SiO₂) are acceptor of oxygen. Common acidic and basic oxides are shown in table below. Flux having BI <1 is called acidic flux, neutral fluxes have 1 < BI < 1.2 while basic fluxes have BI > 1.2. Increase in BI of the flux from 1 to 5 results in significant decrease in sulphur content of the weld. The basic oxides act de-sulphurizer as sulphur is removed from the weld in the form of SO₂ by reaction between oxygen released by basic oxides and S. Thus, the weld is de-sulphurized (Table 4).

Table 4

Type of oxide	Decreasing Strength						
	1	2	3	4	5	6	7
Acidic	SiO ₂	TiO ₂	P ₂ O ₅	V ₂ O ₅			
Basic	K ₂ O	Na ₂ O	CaO	MgO	BaO	MnO	FeO
Neutral	Al ₂ O ₃	Fe ₂ O ₃	Cr ₂ O ₃	V ₂ O ₃	ZnO		

In general, an increase in basicity of the flux up to 1.5 decreases the S and oxygen concentration (from about 900 PPM to 250 PPM) in weld joints as shown in Fig. 58 (a, b). Thereafter, oxygen content remains constant at about 200-250 PPM level despite of using fluxes of high basicity index. Further, there is no consensus among the researchers on the mechanism by which an increase in basicity index decreases the oxygen content.

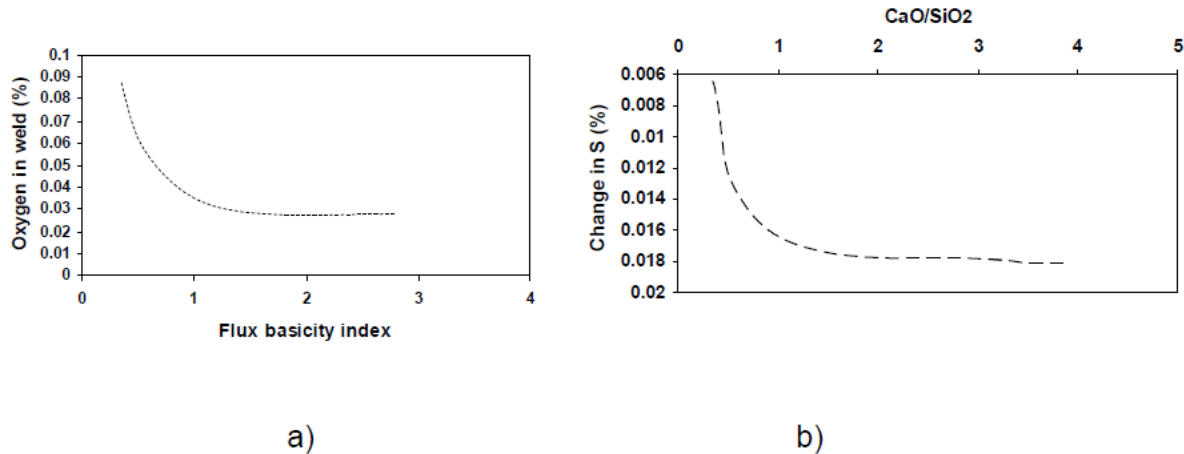


Fig. 58 Influence of basicity of flux on a) oxygen and b) sulphur concentration in weld.

These oxides get decomposed at high temperature in arc environment. Stability of each oxide is different. Oxides with decreasing stability are as follows: (i) CaO, (ii) K₂O, (iii) Na₂O and TiO₂, (iv) Al₂O₃, (v) MgO, (vi) SiO₂, (vii) MnO and FeO. On decomposition, these oxides invariably produce oxygen and result-in oxidation of reactive elements in weld metal.

12. Understanding weldability

Weldability is considered as ease of accomplishing a satisfactory weld joint and can be in determined from quality of the weld joint, effort and cost required for developing the weld joint. Quality of the weld joint however, can be determined by many factors but the weld must fulfil the service requirements. The characteristics of the metal determining the quality of weld joint includes tendency to cracking, hardening and softening of HAZ, oxidation, evaporation, structural modification and affinity to gases. While efforts required for producing sound weld joint are determined by properties of metal system in

consideration namely melting point, thermal expansion coefficient, thermal and electrical conductivity, defects inherent in base metal and surface condition. All the factors adversely affecting the weld quality and increasing the efforts (& skill required) for producing a satisfactory weld joint will in turn be decreasing the weldability of metal.

In view of above, it can be said that weldability of metal is not an intrinsic property as it is influenced by a) all steps related with welding procedure, b) purpose of the weld joints and c) fabrication conditions. Welding of a metal using one process may show poor weldability (like Al welding with SMA welding process) and good weldability when the same metal is welded with some other welding process (Al welding with TIG/MIG). Similarly, a steel weld joint may perform well under normal atmospheric conditions and the same may exhibit very poor toughness and ductility at very low temperature condition. Steps of the welding procedure namely preparation of surface and edge, preheating, welding process, welding parameters, post weld treatment such as relieving the residual stresses, can influence the weldability of metal appreciably. Therefore, weldability of a metal is considered as a relative term.

Weldability of steels

To understand the weldability of steel, it important to look into the different phases, phase mixtures and intermetallic generally found in steel besides the changes in phase that can occur during welding due to heating and cooling cycles. All these aspects can be understood by going through following section presenting significance of Fe-C diagram, time-temperature-transformation diagram and continuous cooling transformation diagram.

Fe-C Equilibrium Phase Diagram

Fe-C diagram is also called iron-iron carbide diagram because these are the two main constituents observed at the room temperature in steel while the presence of other phases depends on the type and amount of alloying elements. It shows the various phase transformations as a function of temperature on heating / cooling under equilibrium conditions.

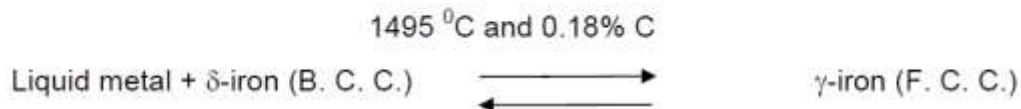
Allotropy and critical temperatures

Change in crystal structure of an element with rise in temperature is termed as allotropy. Iron shows the allotropic behaviour at temperature 910 °C and 1390 °C. Iron changes its crystal structure first from BCC to FCC at 910 °C and then from FCC to BCC at 1390 °C. Therefore, solubility of carbon in iron varies with temperature especially above 910 °C and 1390 °C.

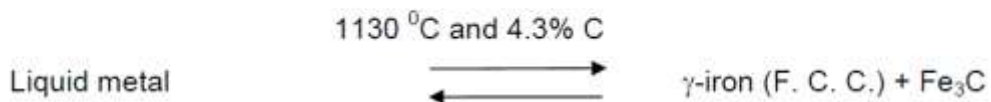
Isothermal Transformations in Fe-C diagram

Three are main reaction points in Fe-C diagram namely peritectic, eutectoid and eutectic, which are of great academic and practical importance. All three reactions take place at a fixed temperature and composition.

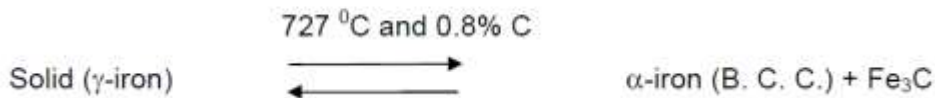
Peritectic reaction



Eutectic reaction



Eutectoid reaction



Proportions of various phases of these transformations can be obtained using lever rule. Fulcrum of the lever depends upon the alloy composition i.e. carbon content. Since these transformations take place at constant temperatures therefore it is easy to find the tie line. Terminal phases (and their compositions) can be obtained using the tie line and alloy compositions.

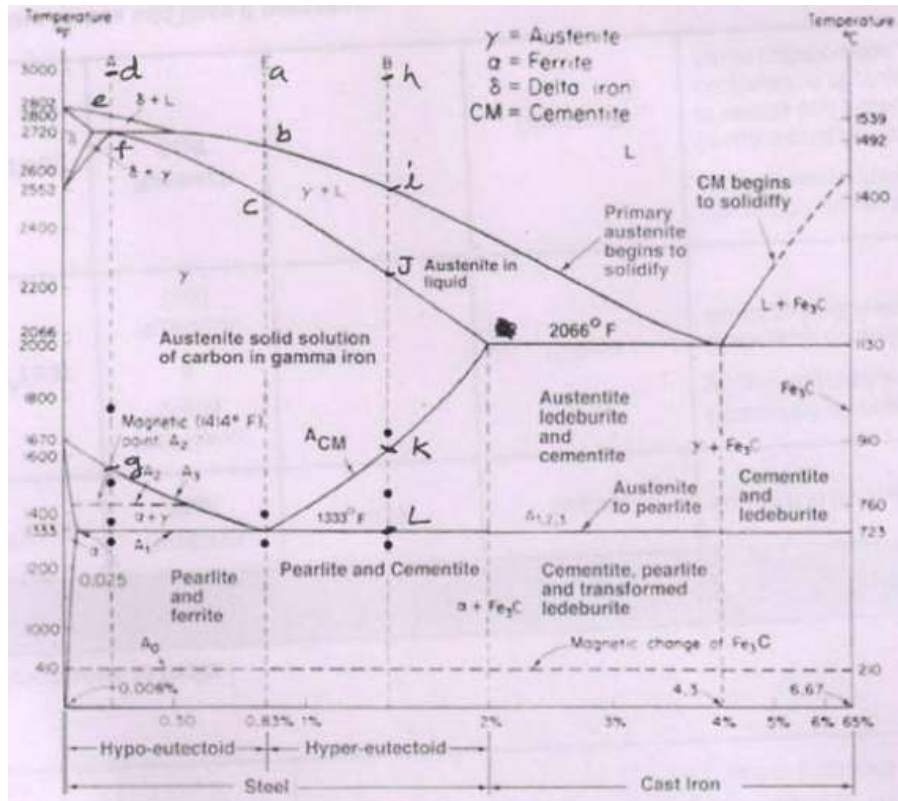


Fig. 59 Fe-C diagram (source: Materials Science and Metallurgy, 4th ed., Pollack, Prentice-Hall, 1988)

Phases appearing in Fe-C diagram are ferrite (α -Fe), austenite (γ -Fe), cementite (Fe_3C), δ iron and mixtures of phases such as pearlite (α -Fe + Fe_3C) and ledeburite (γ -Fe + Fe_3C). Pearlite and ledeburite are the result of eutectoid and eutectic reactions respectively. Details of these phases and their mechanical properties are presented in following section.

Ferrite

Ferrite is an interstitial solid solution of carbon in iron having B. C. C. structure. Solubility of carbon in iron having B. C. C. structure at room temperature is about 0.005% while that at eutectoid temperature (727°C) is 0.025%. Ferrite is a soft, low strength, tough and ductile (50% elongation) phase.

Austenite

Austenite is an interstitial solid solution of carbon in iron having F. C. C. structure. This is not stable below eutectoid temperature (7270C) in plain Fe-C system as it transforms into pearlite below this temperature. Solubility of carbon in iron having F. C. C. structure at temperature 13300C is 2.0% while that at eutectoid temperature (7270C) is 0.8%. Austenite is a comparatively harder, stronger, tougher but of lower less ductility (%elongation) than the ferrite.

Cementite

Cementite is an inter-metallic compound of iron and carbon i.e. iron's carbide (Fe_3C). Cementite contains 6.67% of carbon and has orthorhombic structure. It is the hardest amongst all phases appearing in Fe-C diagram. Its hardness is extremely high while strength is very poor.

Pearlite

Pearlite is a phase mixture of ferrite and cementite and is a result of eutectoid transformation. The pearlite has alternate layers (lamellas) of cementite and ferrite. Strength of pearlite is more than any of the individual phases of which it is made. Mechanical properties i.e. strength, ductility, toughness and hardness of pearlite depends on the inter-lamellar spacing. Thinner plates (layers) of alpha ferrite, Fe_3C results in better mechanical properties.

Ledeburite

Ledeburite is also a phase mixture of austenite and cementite and is formed as a result of eutectic transformation but is observed only above the eutectoid temperature in Fe-C diagram as below this temperature austenite of ledeburite transforms into pearlite.

Effect of Phases on Mechanical Properties

It is important to note that every phase or phase mixture has its own mechanical properties. Some of the phases are very soft (ferrite) and some are extremely hard (cementite). Therefore, variation in proportions / relative amounts of these phases will affect the mechanical properties of steel as a whole. Increase in carbon content in steel linearly increases proportion of pearlite but at the cost of ferrite. Since ferrite is of low strength, soft and ductile while pearlite is hard, strong and of poor ductility and

toughness, hence increase in percentage of pearlite increases strength, hardness and reduces the ductility and toughness of steel as a whole. Cementite appears as an individual phase only above eutectoid composition (steel having carbon > 0.8%). It tends to form a network along the grain boundary of pearlite depending upon carbon content. Complete isolation of pearlite colonies with the cementite (as a result of continuous network of cementite) decreases tensile strength and ductility because mechanical properties of the alloy / steel to a large extent depend upon the properties of phase which is continuous in alloy. Increase in the carbon content above the eutectoid compositions (0.8% C) therefore reduces the strength and ductility because in hypereutectoid steel, network of cementite is formed along the grain boundaries of pearlite and cementite has very low tensile strength (3.0MPa).

Phase Transformation

Steel having 0.8% carbon is known as eutectoid steel. Steels with carbon lesser than 0.8% are known as hypoeutectoid and those having more than 0.8% and less than 2% carbon are called hypereutectoid steels. Fe-C systems having carbon more than 2% are called cast irons. Cast iron having 4.3% carbon is known as eutectic cast iron. Cast irons with carbon less than 4.3 % are known as hypoeutectic and those having more than 4.3% are called hypereutectic cast iron.

12.1 Steel

Eutectoid steel

Transformation of eutectoid steel into various phases on cooling from molten state to the room temperature can be shown by drawing a vertical line through the composition point on E axis (called composition line). No phase transformation occurs until temperature of liquid metal goes down from point 'a' to 'b' on the liquidus. At the point 'b' solidification starts and first of all austenite (with 0.3%C) is formed. Further decrease in temperature results in formation of more and more proportion of austenite whose composition changes along the solidus whereas composition of liquid changes along the liquidus. It shows that carbon content in molten metal increases with the reduction in temperature until it goes down to the point 'c'. On completion of solidification, steel

attains the austenitic state thereafter no phase transformation takes place until it attains eutectoid temperature (723°C). Reduction in temperature decreases the solubility of carbon in austenite. Austenite is supersaturated with carbon as temperature goes below the eutectoid temperature hence austenite rejects the excess carbon leading to the nucleation of cementite along the grain boundary. As rejection of carbon from austenite continues, cementite layer grows toward the center of austenite grain and a very small zone which is depleted of carbon is formed on both the sides of the cementite plate. As concentration of carbon in carbon depleted zone reduces to such an extent when it is enough to dissolve in iron having B. C. C. structure at that temperature austenite transforms into ferrite. Thickness of the cementite or ferrite plates depends on the rate of diffusion and time available for the transformation to take place. As this transformation occurs by nucleation and growth mechanism which is based on diffusion of atoms. Slower the cooling rate, greater is the time available for the transformation and phases to grow hence thicker cementite and ferrite plates are produced. This process continues until whole austenite is transformed into pearlite.

Hypoeutectoid Steel

Transformation of 0.18% C steel during the cooling from molten state to the room temperature is shown by vertical line through the composition point. It is observed that no phase transformation takes place until temperature of liquid metal goes down from point 'd' to 'e' on the liquidus. At the point 'e' solidification starts and first of all δ iron (with 0.03% C) is formed. Further, decrease in temperature results in formation of more and more δ iron whose composition changes along the solidus whereas composition of liquid changes along the liquidus. Liquidus shows that carbon content in molten metal increases with the reduction in temperature. At the temperature of 1495°C, liquid metal (with 0.5% C) and solid δ iron (0.1% C) transform into austenite by peritectic reaction. On completion of solidification, steel attains the complete austenitic state thereafter no phase transformation takes place until it attains temperature corresponding to the point 'g' (i.e. 850°C). At about 850°C, austenite transforms into the ferrite. Further, transformation of austenite into ferrite continues with reduction in temperature until eutectoid temperature is attained. During this transformation, the

composition of austenite changes continuously with increase in carbon content in austenite. As eutectoid temperature is attained carbon content in austenite rises to 0.8% i.e. eutectoid composition. At this temperature, austenite of eutectoid composition transforms into pearlite as discussed above. Proeutectoid phase i.e. ferrite, is formed first from austenite in hypoeutectoid steel and subsequently austenite transforms into pearlite. Hence ferrite is found along the grain boundaries of pearlite. Continuity of ferrite network depends upon the carbon content in hypoeutectoid steel. Reduction in carbon content increases the continuity of ferrite network around the pearlite grains. Increase in carbon content reduces the amount of ferrite and increases the amount of pearlite.

Hypereutectoid steel:

Transformation of hypereutectoid steel is similar to that of hypoeutectoid steel except that proeutectoid phase is cementite instead of ferrite. In this case no phase transformation takes place until temperature of liquid metal goes down from point 'h' to 'l' on the liquidus. At the point 'i' solidification starts and first of all austenite (with 0.8%C) is formed. Further, decrease in temperature results in formation of more and more amount of austenite whose composition changes along the solidus whereas composition of liquid metal goes along the liquidus. It shows that carbon content in molten metal increases with the reduction in temperature until it goes down to the point 'j'. On completion of solidification, steel attains the austenitic state and thereafter no phase transformation takes place until it attains temperature corresponding to the point 'k' (1000°C). At eutectoid temperature, austenite becomes supersaturated with carbon hence austenite rejects the excess carbon which leads to the nucleation of cementite along the grain boundary. Further, decrease in temperature results in formation of more and more cementite from the austenite whose composition changes along the kl. As eutectoid temperature is attained, carbon content in austenite decreases up to the eutectoid composition (0.8%C). At this temperature, austenite of eutectoid composition transforms into pearlite as discussed above. Proeutectoid phase i.e. cementite is formed first from austenite in hypereutectoid steel subsequently austenite transforms pearlite. Hence, cementite is found along the grain boundaries of pearlite.

12.2 Time Temperature Transformation (TTT) Diagram

This diagram shows the transformation of meta-stable austenite phase at constant temperature into various phases as a function of time (Fig. 60). Therefore, it is also known as isothermal transformation diagram. Transformation of austenite into various phases such as pearlite, bainite and martensite depends on the transformation temperature. Time needed to start the transformation of austenite into pearlite or bainite is called incubation period which is initially low at lower transformation temperature and then increases as transformation temperature increases. TTT Diagram for eutectoid C-steel has C shape due to variation in time needed to start and end the transformation of austenite at different transformation temperature. This curve has a nose at about 550°C. Transformation of austenite into pearlite takes place on exposure at any constant temperature above the nose. It is observed that higher the transformation temperature more is the time required for starting and completing the transformation. Transformation of austenite into pearlite or bainite occurs by nucleation and growth process. Hence, at high temperature high growth rate, low nucleation rate coupled with longer transformation time results in coarse pearlitic structure whereas at low transformation temperatures fine pearlitic structure is produced because of low growth rate, high nucleation rate and short transformation time. High transformation temperature lowers the strength and hardness of steel owing to the coarse pearlitic structure.

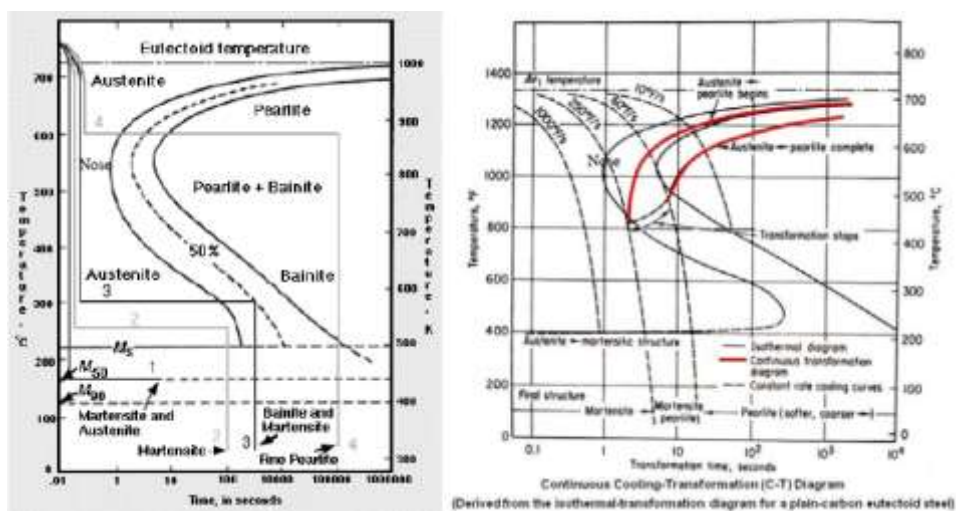


Fig. 60 Time-temperature-transformation diagram a) isothermal transformation and b) TTT diagram superimposed with different cooling curves

Transformation of austenite at a temperature below the nose of the curve results in bainitic structure. Bainite is a very fine intimate mixture of ferrite and cementite like pearlite. However, pearlite is a mixture of lamellar ferrite and cementite. That is why bainite offers much better strength, hardness and toughness than the pearlite. Degree of fineness of bainite also increases with the reduction in transformation temperature like pearlitic transformation. Bainite formed at high temperature is called feathery bainite while that formed at low temperature near the M_s temperature is called acicular bainite. Transformation of austenite at a temperature below the M_s temperature results in hard and brittle phase called martensite structure. Martensite is a supersaturated solid solution of carbon in iron having body centered tetragonal (B.C.T) structure. This austenite to martensite transformation is a thermal transformation as it takes place by diffusionless process. Rapid quenching/cooling from austenitic temperature to a temperature below the ' M_s ' prevents any kind of atomic diffusion. Therefore carbon atoms, which are easily accommodated within FCC unit cell (in austenite) at high temperature, should be rejected at low temperature because of reduction in solid solubility. But at such a low temperature (below ' M_s ') diffusion is prevented and that leads to formation of supersaturated solid solution of carbon in iron having BCC structure. This super saturation of carbon in iron (BCC) causes the distortion of the BCC lattice structure and makes it BCT by increasing the c/a ratio more than 1. Degree of distortion is measured in terms of c/a ratio. This ratio depends up on the carbon content. Increase in carbon content up to 0.8%, increases the c/a ratio. The c/a ratio can be directly related with the increase in hardness, as there is linear relation between the two up to 0.8% carbon content. Position of transformation lines and nose depends on steel composition, homogeneity of austenite and grain size. For each composition of steel, there will be just one TTT diagram. Steel other than eutectoid composition will have one more line initiating from the nose in TTT diagram corresponding to transformation of austenite into proeutectoid phase. In case of hypoeutectoid steel, first austenite forms ferrite as a proeutectoid phase, subsequently it transforms into pearlite whereas the proeutectoid phase for hypereutectoid steel is cementite. Addition or reduction in carbon % in steel with respect to eutectoid composition shifts the nose of TTT diagram. For hypoeutectoid steels nose of the curve is shifted towards the left (reduced incubation

time) whereas for hypereutectoid steels nose is shifted to right as compared to that for eutectoid steel. Temperature corresponding to start (M_s) and end (M_f) of martensite transformation is found a function of alloy compositions. Addition of alloying elements lowers these temperatures.

12.3 Continuous Cooling Transformation (C.C.T.) Diagram

CCT curve shows the transformation of austenite into various phases as a function of time at different cooling rates but not at constant temperature like in TTT diagram. This diagram is similar to that of TTT diagram except that under continuous cooling conditions (when temperature changes continuously) nose of the curve is shifted to right in downward direction and bainite transformation part as obtained in TTT diagram (below the nose) is absent in CCT diagram. Hence, continuous cooling diagram for eutectoid steel has only two lines above M_s , corresponding to the start and end of pearlite transformation (Fig. 61). Various lines AB, KN, QR, ZO showing the reduction in temperature with time representing the different cooling rates called cooling curves. A very low cooling rate 'AB' results in the transformation of austenite into coarse pearlite starts at T_{s1} temperature and ends at T_{s2} temperature. Therefore, transformation takes place over a range of temperature from T_{s1} to T_{s2} . Such low cooling rates are used for annealing of steels which increases the softness. At somewhat higher cooling rate (KN) the transformation of austenite into pearlite starts at T_{s3} temperature and ends at T_{s4} temperature. Therefore, effective transformation takes place over a range of temperature from T_{s3} to T_{s4} . Grain size depends on the transformation temperature. High transformation temperature produces coarse grain. Since the continuous cooling conditions result in transformation over a range of temperature say T_{s1} to T_{s2} hence the grain size also varies accordingly. Therefore, at start of transformation coarser pearlite grains are formed than that at end of transformation. High cooling rate reduces the effective transformation temperature hence fine grain structure is produced. Such cooling rates are used for normalizing of steel. Normalizing increases the strength, hardness and toughness due to finer grain structure.

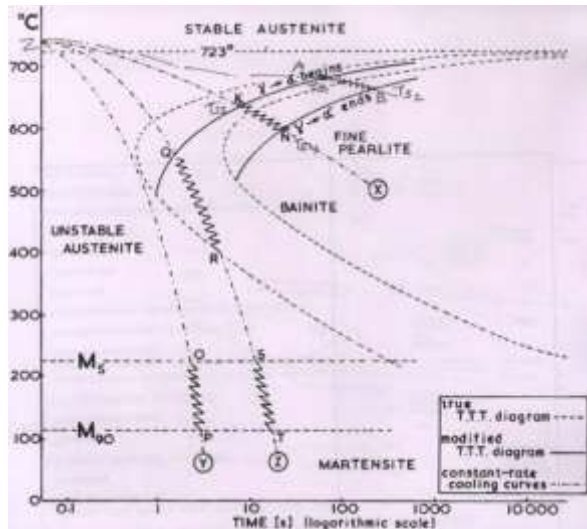


Fig. 61 Continuous cooling transformation diagram

Cooling curve 'QR' is tangential to 25% transformation line where 25% austenite has transformed into pearlite and 75% austenite is yet to transform. Thereafter, transformation of austenite stops and no further transformation takes place until its temperature goes down to M_s . As austenite crosses the M_s temperature remaining 75% austenite begins to transform into the martensite. This transformation line is expected to result in about 75% of martensite and approx. 25% pearlite. Further, higher cooling rate line 'ZO', which is tangential to the nose of the CCT diagram does not cause any transformation of austenite into pearlite. Austenite remains stable until M_s temperature is reached. Further reduction in temperature transforms the austenite into the martensite. Moreover, complete transformation of austenite into martensite depends on the quenching temperature. If quenching temperature is below the ' M_f ' then only whole austenite is expected to transform into the martensite; otherwise some un-transformed austenite is left in steel called retained austenite. Retained austenite is comparatively soft, therefore, its presence reduces the hardness of steel. Amount of retained austenite depends on the quench temperature between M_s and M_f . Lower the transformation temperature (between M_s and M_f), smaller is the amount of retained austenite in steel. There is non-linear relationship between the amount of austenite transforming into martensite and quenching temperature in range of M_s and M_f . Minimum cooling rate that ensures complete transformation of austenite into martensite and avoids the formation

of soft phases/phase mixtures (like pearlite) is called critical cooling rate (CCR). Critical cooling rate depends on the position of the nose, which is governed by the alloy composition, grain size and homogeneity of austenite. To take into account the effect of all alloying elements on the critical cooling rate, carbon equivalent is used.

High carbon equivalent lowers the critical cooling rate hence less drastic cooling is required for hardening. In general, presence of all alloying elements (except Co) shifts the nose of CCT diagram towards right (conversely increase the incubation period to begin transformation) which in turn reduces the critical cooling rate and increases hardenability. Reduction in carbon content increases the critical cooling rate and makes hardening of steel more difficult. Fine grained austenite starts the transformation earlier so nose of curves is shifted to left (reduces the incubation period for transformation). This increases the critical cooling rate. On the other hand coarse grain structure reduces the critical cooling rate which in turn increases the hardenability. Similarly inhomogeneous austenite (due incomplete transformation/austenitizing during heating) also reduces the transformation time, shifting nose of CCT curve to left and so increases the critical cooling rate.

12.4 Weldability of steel and composition

Weldability of steels can be judged by two parameters (a) cleanliness of weld metal and (b) properties of HAZ. Cleanliness of weld metal is related with presence of inclusion in the form of slag or gases whereas HAZ properties are primarily controlled by hardenability of the steel. Proper shielding of arc zone and degassing of molten weld metal can be used to control first factor. Proper shielding can be done by inactive gases released by combustion of electrode coatings in SMA or inert gases (Ar, He, Co₂) in case of TIG, MIG welding. Hardenability of steel is primarily governed by the composition. All the factors increasing the hardenability adversely affect the weldability because steel becomes more hard, brittle and sensitive to fracture/cracking, therefore it needs extra care. So, more the precautions should be taken to produce a sound weld joint. Addition of all alloying elements (C, Mn, Ni, W, Cr etc.) except cobalt increases the hardenability which in turn decreases the weldability. To find the combined effect of alloying elements on hardenability/weldability, carbon equivalent (CE) is determined.

The most of the carbon equivalent (CE) equations used to evaluate weldability depends type of steel i.e. alloy steel or carbon steel.

Common CE equation for low alloy steel is as under:

$$CE = C + Mn/6 + (Cr + Mo + V)/5 + (Ni + Cu)/15$$

(elements are expressed in weight percent amounts)

For low carbon steels and micro-alloy steels, CE is obtained using following equation:

$$CE = C + Si/25 + (Mn + Cr)/16 + (Cr + Ni + Mo)/20 + V/15$$

From the Welding Journal, for low carbon, micro-alloyed steels, Ito-Besseyo carbon equivalent:

$$C_{eq} = C + Si/30 + (Mn + Cu + Cr)/20 + Ni/60 + Mo/15 + V/10 + 5 \cdot B$$

Since the effect of different alloying elements on hardenability of steel is different therefore, their influence on weldability will also be different. In general, high the CE steel need high preheat temperature to produce crack free weld joint. Following point can be kept in mind as broad guidelines for welding steel.

❖	CE < 0.45	No preheat required,
❖	0.45 < CE < 0.7	200-500 ⁰ C of preheat may be used
❖	CE > 0.7	Can not be welded

Thickness of plate to be welded affects the cooling rate which in turn influences the hardening and cracking tendency. To take into account the thickness of plate above criteria is modified to get compensated carbon equivalent (CCE) relation.

$$CCE = CE + 0.00425t$$

Where t is the thickness of plate in mm

CCE < 0.4 No preheat required,

0.4 < CCE < 0.7 200-500⁰C of preheat may be used

CCE > 0.7 Cannot be welded

From the weldability point of view, steels can be placed in five categories based on chemical composition, mechanical properties, heat treatment conditions, and high temperature properties: a) carbon steel, b) high strength low alloy steel, c) quench and tempered steel, d) heat treatable steel and e) Cr-Mo steel. These steels need to be

welded in different forms such as sheets, plates, pipes, forgings etc. In case of steel welding, it is important to consider thickness of base metal as it affects the heat input, cooling rate and restraint conditions during welding.

12.5 Different types of steel and welding

Carbon steel generally welded in as rolled condition (besides annealed and normalized one). The weldable carbon steel is mostly composed of carbon about 0.25 %, Mn up to 1.65%, Si up to 0.6% with residual amount of S and P below 0.05%. High strength low alloy steel (HSLA) is designed to have yield strength in range of 290-550 MPa using alloying concentration lesser than 1% in total. These can be welded in conditions same as that of carbon steel. Quench and tempered (Q & T) steels can be a carbon steel or HSLA steel category that are generally heat treated to impart yield strength in range of 350 to 1030 MPa. Heat treatable steels generally contain carbon more than carbon steel or HSLA steels, to increase their response to the heat treatment (Kou, S welding metallurgy, John Willey, 2003). However, presence of high carbon in these steels increases the hardenability which in turn decreases the weldability owing to increased embrittlement and cracking tendency of heat affected zone. Further, PWHT of heat treatable steel weld joints is done to enhance their toughness and induce ductility because presence of high carbon in these heat treatable steels. Cr-Mo steels are primarily designed to have high resistance to corrosion, thermal softening and creep at elevated temperature (up to 700 °C). Therefore, these are commonly used in petrochemical industries and thermal power plants. Weld joints of Cr-Mo steels are generally given PWHT to regain ductility, toughness, and corrosion resistance and reduce the residual stresses.

13. Common problems in steel welding

Cracking of HAZ due to hardening

The cooling rate experienced by the weld metal and HAZ during welding generally exceeds the critical cooling (CCR) which in turn increases the chances martensitic transformation. It is well known from the physical metallurgy of the steels that this transformation increases the hardness and brittleness and generates tensile residual

stresses. This combination of high hardness and tensile residual stresses makes the steel prone to the cracking.

Cold cracking

Another important effect of solid state transformation is the cold cracking. It is also termed as delayed/hydrogen induced cracking because these two factors (delay and hydrogen) are basically responsible for cold cracking. It can be observed that increase in stress decreases the time required for initiation and complete fracture by cold cracking. Origin of this problem lies in the variation of solubility of hydrogen in the steel with the temperature. Reduction in temperature decreases solubility of hydrogen in solid state due to change in crystal structure from F. C. C. to B. C. C. High temperature transformation (like austenite to pearlite or bainite) allows escape of some of excess hydrogen (beyond the solubility) by diffusion. But in case of low temperature transformation (austenite into martensite), when rate of diffusion reduces significantly, hydrogen cannot escape and is trapped in steel as solid solution. Dissolved hydrogen has more damaging effect in presence of martensite and the same has been explained below. Hydrogen dissolved in atomic state at low temperature tends to diffuse out gradually toward the vacancies and other cavities. At these locations atomic hydrogen converts into diatomic H₂ gas and with time, continued diffusion of hydrogen towards these discontinuities as this gas starts to build up pressure in the cavities (Fig. 62). If the pressure exceeds the fracture stress of metal, cavities expands by cracking. Cracking of metal increases the volume which in turn reduces the pressure. Due to continuous diffusion of hydrogen toward the cavities after some time again as pressure exceeds the fracture stress, and crack propagates further. This process of building up on pressure and propagation of cracks is repeated until complete fracture takes place without external load. Since this type cracking and fracture takes place after some time of welding hence it is called delayed cracking. Delay for complete fracture depends on the following factors:

Hardenability of steel

Amount of hydrogen dissolved in atomic state

Magnitude of residual tensile stress

Hardenability of steel affects the critical cooling rate. Steel of high hardenability promotes the martensitic transformation therefore it has high hardness and brittleness. High hardness increases the cracking tendency whereas soft and ductile metals reduce it. Crack tips are blunted in case of ductile metals so they reduce the cracking sensitivity and increases the stress level for fracture. As a result crack propagation rate is reduced in case of ductile and low strength metal. Therefore, steels of low hardenability will therefore minimize the cold/delayed cracking. Larger the amount of dissolved hydrogen faster will be the delayed/hydrogen induced cracking.

Remedy

Use of low hydrogen electrodes.

Preheating of plates to be welded.

Use of austenitic electrodes.

Use of low hydrogen electrodes will reduce the hydrogen content in weld metal. Preheating of the plate will reduce the cooling rate, which will allow longer time for gases to escape during the liquid to solid state and solid-solid transformation. It may also reduce the cooling rate below the critical cooling rate so that martensitic transformation can be avoided and austenite can be transformed into softer phases and phase mixtures like pearlite, bainite etc. These soft phases further reduce the cracking tendency. Use of austenitic electrode also avoids the martensite formation and provides mainly austenite matrix in weld zone. Austenite is a soft and tough phase having high solubility (%) for hydrogen. All these characteristics of austenite reduce the cold/delayed cracking.

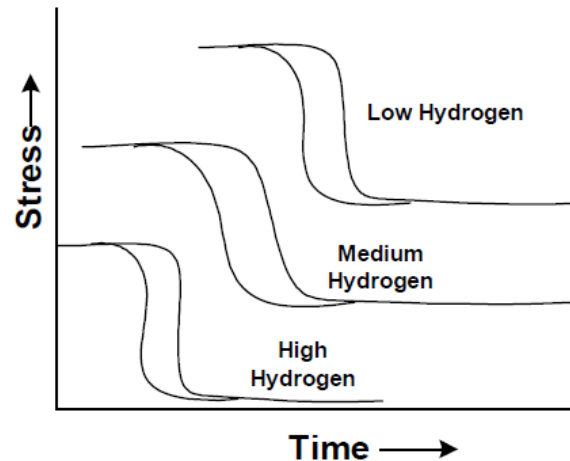


Fig. 62 Schematic diagram showing effect of hydrogen concentration on cold cracking at different stress levels

14. Schaeffler diagram

Steel is referred to as "high-alloy" if it contains at least 5% alloying elements. Properties which characterise these steels are:

- Corrosion resistance
- High temperature resistance
- Heat and scale resistance
- Low-temperature impact resistance

The combination and interaction of the alloying elements form different structures in the steel. These structures benefit certain properties of the steel.

Alloying elements fall basically into two groups.

- Ferrite formers:
 - These limit or inhibit the formation of austenite.
- Austenite formers:
 - These increase the level of austenite.

Chromium and nickel are among the most important alloying elements here. All ferrite formers have a chromium equivalent and all austenite formers a nickel equivalent.

Our EWM Schaeffler program is a powerful tool to determine the right EWM welding consumable, depending on which parent metal and expected dilution you select or enter.

Ferrite is important in avoiding hot cracking in during cooling from welding of austenitic stainless steels. 'Constitution diagrams' are used to predict ferrite levels from the composition by comparing the effects of austenite and ferrite stabilising elements. The Schaeffler and Delong diagrams are the original methods of predicting the phase balances in austenitic stainless steel welds.

Nickel and chromium equivalents

A 'nickel equivalent' is calculated for the austenite stabilising elements and a 'chromium equivalent' ferrite stabilising elements. These are used as the axes for the diagrams, which show the compositional equivalent areas where the phases austenite, ferrite, martensite (and mixtures of these) should be present. Although intended to show the phase balance of weld fillers, these diagrams can also be used to illustrate the phase balance of the 'parent' material. There are different diagrams for different alloy systems.

Schaffler Diagram

The nickel and chromium equivalents use the formulae.

$$\text{Ni (eq)} = \text{Ni} + (30 \times \text{C}) + (0.5 \times \text{Mn})$$

$$\text{Cr (eq)} = \text{Cr} + \text{Mo} + (1.5 \times \text{Si}) + (0.5 \times \text{Nb})$$

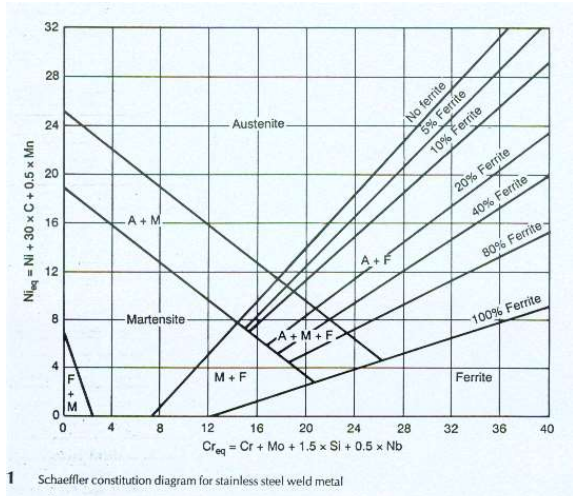


Fig 63

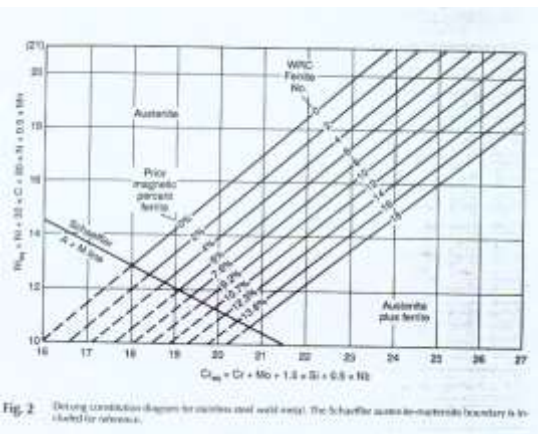


Fig 64

Delong Diagram

This refines the Schaeffler diagram by taking account of the strong austenite stabilising tendency of nitrogen. The chromium equivalent is unaffected but the nickel equivalent is modified to

$$Ni (eq) = Ni + (30 \times C) + (0.5 \times Mn) + (30 \times N)$$

The diagram, identifying the phase boundaries is shown below. This shows the ferrite levels in bands, both as percentages, based on metallographic determinations and as a ferrite number 'FN', based on magnetic determination methods.

Module-III

Heat flow in welding, significance, theory of heat flow, cooling rate determination, selection of welding parameters based on heat flow analysis, residual stress and its measurement, types and control of distortion.

15. Introduction to Heat Flow in Welding

Arc welding processes involve the melting of the faying surfaces and the filler metal, if any, followed by solidification of the molten weld metal. Melting and solidification steps of welding are associated with the flow of heat and are affected by rate of heat transfer in and around the weld metal. Metallurgical structure of metal in weld and region close to the weld metal is mainly determined by the extent of rise in temperature and then cooling rate experienced by the metal at particular location of HAZ and weld. Further, differential heating and cooling experienced of different zones of weld joint cause not only metallurgical heterogeneity but also non-uniform volumetric change which in turn produces the residual stresses. These residual stresses adversely affect the mechanical performance of the weld joint besides distortion in the welded components if proper care is not taken. Since heating, soaking and cooling cycle affect the metallurgical & mechanical properties, development of residual stresses and distortion of the weld joints therefore it is pertinent to study various aspects related with heat flow in welding such as weld thermal cycle, cooling rate and solidification time, peak temperature, width of heat affected zone. Further, mechanisms of development of residual stresses and common methods relieving residual stresses apart from the distortion and their remedy will be discussed on heat flow in welding.

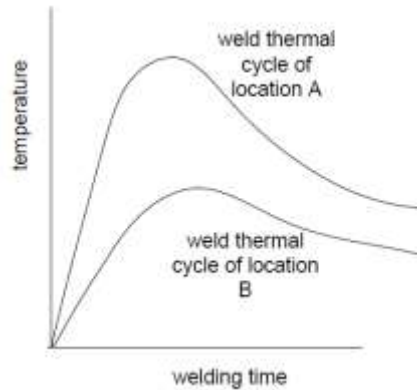


Fig. 65 Schematic of weld thermal cycle of two different locations away from the weld centerline

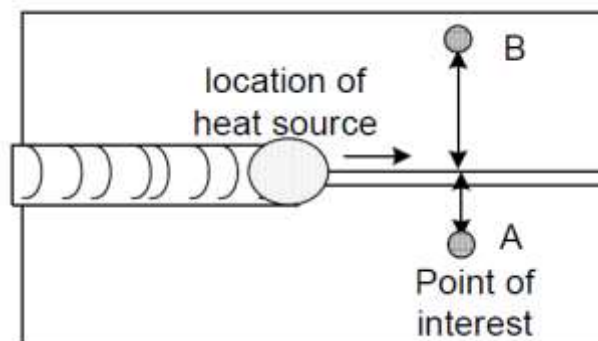


Fig. 66 Schematic of welding showing location of two points A & B

15.1 Weld Thermal Cycle

Weld thermal cycle shows variation in temperature of a particular location (in and around the weld) during the welding as a function of welding time. As the heat source (welding arc or flame) approaches close to the location of interest first temperature increases heating regime followed by gradual decrease in temperature cooling regime. A typical weld thermal cycle shows (Fig. 65) the rate of heating (slope of a b), peak temperature, and time required for attaining the peak temperature, cooling rate (slope of b c). Since distance of the point of interest away from the weld centerline directly affects all the above parameters heating and cooling rate, peak temperature of weld thermal cycle therefore each location/point offers different and unique weld thermal cycle (Fig. 66). In general, an increase in distance of point of interest away from the weld centerline:

- decreases the peak temperature

- decreases the rate of heating and cooling
- increases time to attain peak temperature
- decreases rate of cooling with increase in time

Factors affecting welding thermal cycle

However, weld thermal cycle varies with distance from the weld center line but it is also influenced by heat input rate, amount of heat supplied for welding, weldment geometry, thermal properties of base metal and initial plate temperature. Rate of heat input is primarily governed by the energy density of heat input source which to a great extent depends upon the welding process being used for development of weld joints besides the welding parameters. High energy density processes like plasma arc welding and laser beam welding offer higher rate of heating, peak temperature and cooling rates than low energy density processes such as gas welding, shielded metal arc welding as shown in Fig. 67. Higher is the energy density of welding process, lower will be the heat input. Weld geometry parameters such as thickness of plates being welded also affect the heating rate, soaking time and cooling rate for a given rate of heat input (welding parameters) owing to changes in heat transfer conditions. In general, an increase in thickness of plate increases the rate of heat transfer from the weld pool/heat affected zone to the base metal which in turn a) decreases the high temperature retention time of HAZ, b) decreases the solidification time and c) increases the cooling rate experienced by the HAZ and weld metal.

Thermal properties of metal like thermal conductivity and specific heat also have effect on weld thermal cycle similar to that of thickness of plates as they increase the rate of heat transfer from the weld metal and HAZ. Preheating of the plates reduces the rate of heating and cooling and increases the peak temperature and soaking period above certain temperature because preheating reduces the rate of heat transfer away from the weld zone. Peak temperature near the weld fusion boundary decides the width of heat affected zone (HAZ). Heating and cooling rate affect the microstructure of weld metal and HAZ therefore weld thermal cycle of each point becomes of great interest especially in structure sensitive metals like high carbon steels.

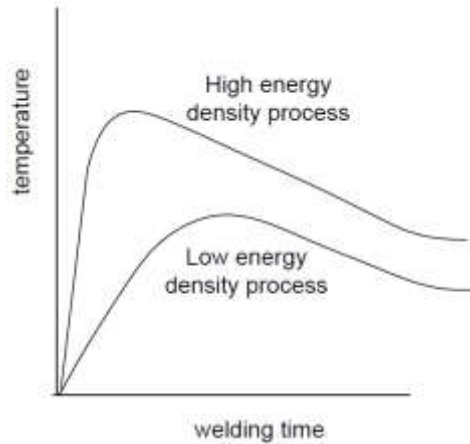


Fig. 67 Influence of energy density of heat source related with welding process on weld thermal cycle of HAZ.

15.2 Cooling Rate

The final microstructure of weld zone and HAZ is primarily determined by the cooling rate (CR) from the peak temperature attained due to weld thermal cycle during welding. Cooling rate above a particular temperature say 550°C for plain carbon eutectoid steel is of great importance in case of hardenable steel where a cooling rate (CR) determines the final microstructure and mechanical properties of weldment and HAZ. Since microstructure of hardenable steel has direct correlation with mechanical properties therefore, structure sensitive mechanical properties are affected by the cooling rate experienced by the weld metal and heat affected zone.

This is evident from the continuous cooling diagram of hypo-eutectoid steel as shown in Fig. 68. In the diagram, letter A, F, P, B, M indicates regions of austenite, ferrite, pearlite, bainite and martensite respectively.

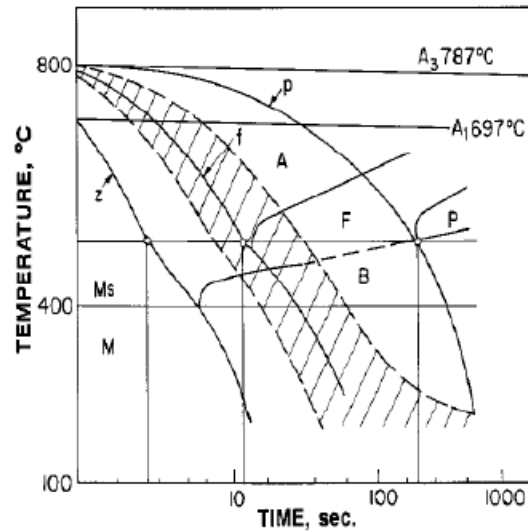


Fig. 68 Effect of cooling on structure of weld joints shown in form of CCT diagram

Weld thermal cycle indicates both heating and cooling rate. Cooling rate varies as a function of time, location of point of interest and temperature (at any moment on commencement of the cooling) during cooling regime of weld thermal cycle. The cooling rate calculation for HAZ of hardenable steel weld joint is mostly made at 550°C (corresponding to nose temperature of CCT) as cooling rate at this temperature predominantly decides the end microstructure and mechanical properties of the HAZ and weld joint. During welding, two welding parameters dictate the cooling rate a) net heat input during the welding and b) initial plate temperature besides the thermal and dimensional properties of material being welded. In general, increases in heat input decreases the cooling rate while reverse happens with increase of initial plate temperature during welding of a given metal having specific thickness and thermal properties. An increase in both heat input and initial plate temperature raises temperature of base metal around the weld which in turn decreases the rate of transfer away from the weld zone primarily due to reduction in temperature difference between the weld zone and surrounding base metal. Reduction in heat transfer rate from the weld metal to the base metal with increase in heat input and initial plate temperature means decrease in cooling rate. In view of above, major practical application of cooling

rate equation is to determine the preheat requirement for plate to be welded so as to avoid critical cooling rate in weld and HAZ.

Net heat input (H_{net}) during welding is obtained using following relationship:

$$H_{net} = f \cdot VI/S$$

where V is arc voltage (V), I welding current (A) and S welding speed mm/sec and f is the fraction of heat generated and transferred to the plate.

Example

Calculate the net heat input used during welding of plates if welding of steel plate is given below:

- Welding current: 150 A
- Arc voltage: 30 V
- Welding speed: 0.5 mm/sec
- 80 % of heat generated by the arc is used for welding.

Solution

$$\begin{aligned} \text{Net heat input: } H_{net} &= f \cdot VI/S \\ &= 0.8 \times 30 \times 150 / 0.5 \\ &= 600 \text{ J/mm} \\ &= 0.6 \text{ kJ/mm} \end{aligned}$$

15.3 Critical cooling rate (CCR) under welding conditions

To determine the critical cooling rate for a steel plate under welding conditions, bead on plate welds are made with varying heat input. On the basis of thickness of the plate (5 mm) to be welded suitable electrode diameter is chosen first and then accordingly welding current and arc voltage are selected (20V, 200A, $T_o=300C$) for bead-on-plate (BOP) welding. Number of BOP welds is deposited using increasing welding speed (8, 9, 10, 11, 12.....mm/sec). Once the BOP weld is completed at different welding speed, transverse section of weld is cut to measure the hardness.

Thereafter, hardness vs. welding speed plot is made to identify the welding speed above which abrupt increase in hardness of the weld and HAZ takes place. This welding

speed is identified as critical welding speed (say 10mm/min in this case) above which cooling rate of the weld & HAZ becomes greater than critical cooling rate. This abrupt increase in hardness of the weld and HAZ is attributed to martensitic transformation during welding as cooling rate becomes greater than critical cooling rate owing to the reduction in heat input (H_{net}) with increase of welding speed. Using welding conditions corresponding to this critical welding speed for a given steel plate, critical cooling rate can be calculate using appropriate cooling rate equation.

Corresponding $H_{net} = f \times VI/S = 0.9 \times 20 \times 200 / 10 = 360 \text{ J/mm}$ or 0.36 kJ/mm .

Calculate relative plate thickness (RPT) parameter for these conditions: $h [(T_i - T_0)C/H_{net}]^{1/2} : 0.31$

RPT suggests use of thin plate equation for calculating the cooling rate:

$$2\pi k\rho c(h/Q)(t_c - t_0)^3$$

Cooling Rate (R):

$5.8 \text{ } ^\circ\text{C/s}$ and it will be safer to consider CCR: $6 \text{ } ^\circ\text{C/s}$

Similarly these equations can also be used for calculating the cooling rate or identifying the preheat temperature to avoid CCR for a particular location under a given set of welding conditions.

Peak temperature and Heat Affected Zone

The weld thermal cycle of a particular location exhibits peak temperature and cooling rate as function of time apart from other factors.

Peak temperature distribution around the weld-centre line determines a) shape of the weld pool, b) size of heat affected zone and c) type of metallurgical transformation and so mechanical properties of weld and HAZ.

Variation in heat input and initial plate temperature affects the peak temperature distribution on the plates along the weld line during welding. An increase in heat input by increasing the welding current (for a given welding speed) in general increases the peak temperature of a particular location and makes the temperature distribution equal around the welding arc (almost circular or oval shape weld pool). Increase in welding speed however makes the weld pool (peak temperature distribution) of tear drop shape

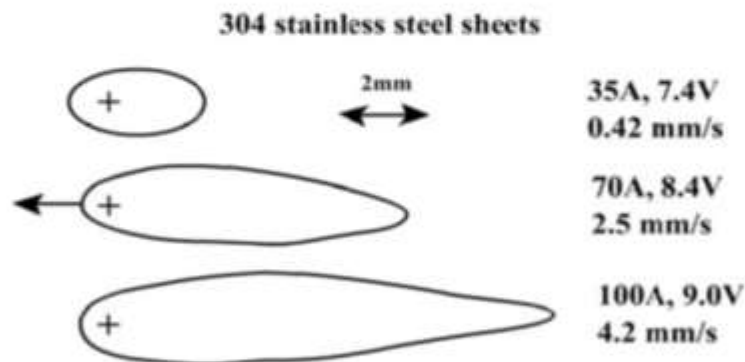


Fig 69 Effect of welding parameters on weld pool profile as dictated by peak temperature

Cooling from the peak temperature determines final microstructure of the weld and heat affected zone. Therefore, peak temperature in the region close to the fusion boundary becomes of great engineering importance as metallurgical transformations (hence mechanical properties) at a point near fusion boundary are influenced by peak temperature (Fig. 20.2). Peak temperature at any point near the fusion boundary for single pass full penetration weld can be calculated using following equation.

$$1/(t_p - t_o) = (4.13\rho chY / H_{net}) + (1/(t_m - t_o)) \dots \dots \dots (3)$$

Similarly these equations can also be used for calculating the cooling rate or identifying the preheat temperature to avoid CCR for a particular location under a given set of welding conditions.

Peak temperature and Heat Affected Zone

The weld thermal cycle of a particular location exhibits peak temperature and cooling rate as function of time apart from other factors.

Peak temperature distribution around the weld-centre line determines a) shape of the Where t_p is peak temperature in $^{\circ}\text{C}$, t_0 is initial temperature in $^{\circ}\text{C}$, t_m is melting temperature in $^{\circ}\text{C}$, H_{net} is net heat input, J/mm, h is plate thickness in mm, Y is width of HAZ in mm and ρc is volumetric specific heat ($\text{J}/\text{mm}^3\text{ }^{\circ}\text{C}$).

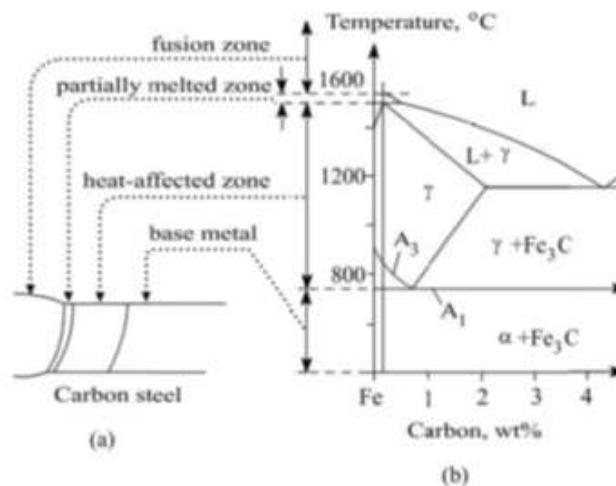


Fig 70 Schematic showing relationship between Fe-C diagram and different zones of weld joints (S Kou, Welding metallurgy, 2003)

This equation can be used for a) calculating peak temperature at a point away from the fusion boundary, b) estimating width of heat-affected zone and c) studying the effect on initial plate temperature/preheating and heat input on width of HAZ. Careful observation of equation reveals that an increase in initial plate temperature and net heat input will increase the peak temperature at y distance from the fusion boundary and so width of heat affected zone.

To calculate the width of HAZ, it is necessary to mention the temperature of interest/ critical temperature above which microstructure and mechanical properties of a metal will be affected by application of welding heat. For example, the plain carbon steels are subjected to metallurgical transformation above 727°C i.e. lower critical temperature, hence temperature of interest/ critical temperature for calculating of HAZ width becomes 727°C . Similarly a steel tempered at 300°C after quenching

On replacing of values of different factors, in $1/(t_p-t_o) = (4.13\rho chY / H_{net}) + (1/(t_m-t_o))$ the peak temperature at distance 3 mm, 1.5 mm and 0 mm is obtained as 1184 °C, 976°C and 1510 °C respectively.

15.4 Solidification Rate

The solidification of weld metal takes place in three stages a) reduction in temperature of liquid metal, b) liquid to solid state transformation and c) finally reduction in temperature of solid metal up to room temperature. The time required for solidification of weld metal depends up on the cooling rate. Solidification time is the time interval between start to end of solidification. Solidification time is also of great importance as it affects the structure, properties and response to the heat treatment of weld metal. It can be calculated using following equation:

$$\text{Solidification time of weld (S}_t\text{)} = LQ/2\pi k\rho c(t_m-t_o)^2 \text{ in sec.....(5)}$$

Where L is heat of fusion (for steel 2 J/mm³)

Above equation indicates that solidification time is the function of net heat input, initial plate temperature and material properties such as latent heat of fusion (L), thermal conductivity (k), volumetric specific heat (ρC) and melting point (t_m). Long solidification time allows each phase to grow to a large extent which in turn results in coarse-grained structure of weld metal. An increase in net heat input (with increase in welding current / arc voltage or reduction in welding speed) increases the solidification time. An increase in solidification time coarsens the grain structure which in turn adversely affects the mechanical properties. Non-uniformity in solidification rates in different regions of molten weld pool also brings variation in grain structure and so mechanical properties. Generally, centerline of the weld joint shows finer grain structure (Fig. 71) and better mechanical properties than those at fusion boundary primarily because of difference in solidification times. Micrographs indicate the coarser structure near the fusion boundary than the weld center.

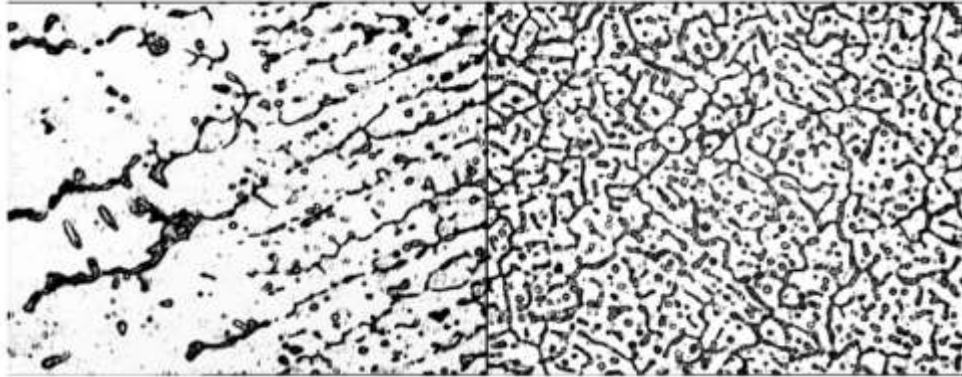


Fig. 71 Variation in microstructure of weld of Al-Si alloys of a) fusion boundary and b) weld centre owing to difference in cooling rate (200X)

Example

A single pass full penetration weld pass is made using net heat input at the rate of 500 J/mm on steel having $\rho c = 0.0044 \text{ J/mm}^3 \text{ }^\circ\text{C}$, $t = 5 \text{ mm}$, $t_0 = 25^\circ\text{C}$, $t_m = 1540^\circ\text{C}$, and thermal conductivity $k = 0.025 \text{ J/mm}\cdot\text{s}\cdot^\circ\text{C}$ and latent heat of fusion 2.4 J/mm^3 .

Determine the solidification time.

Solution

Solidification time: $LQ/2\pi k\rho c(t_m - t_0)^2$ in sec

Solidification time: $2.4 \times 500 / (2\pi \times 0.025 \times 0.0044 (1540 - 25)^2)$ in sec

Solidification time : $1200/1585.54$

Solidification time : 0.75 sec

15.5 Residual stresses

Residual stresses are locked-in stresses present in the engineering components even when there is no external load and these develop primarily due to non-uniform volumetric change in metallic component irrespective of manufacturing processes such as heat treatment, machining, mechanical deformation, casting, welding, coating etc. However, maximum value of residual stresses doesn't exceed the elastic limit of the metal because stresses higher than elastic limit leads to plastic deformation and thus residual stresses greater than elastic limit are accommodated in the form of distortion of components. Residual stresses can be tensile or compressive depending up on the location and type of non-uniform volumetric change taking place due to differential

heating and cooling like in welding and heat treatment or localized stresses like in contour rolling, machining and shot peening etc.

Residual stresses in welding

Residual stresses in welded joints primarily develop due to differential weld thermal cycle (heating, peak temperature and cooling at the any moment during welding) experienced by the weld metal and region closed to fusion boundary i.e. heat affected zone (Fig. 71). Type and magnitude of the residual stresses vary continuously during different stages of welding i.e. heating and cooling. During heating primarily compressive residual stress is developed in the region of base metal which is being heated for melting due to thermal expansion and the same (thermal expansion) is restricted by the low temperature surrounding base metal.

After attaining a peak value compressive residual stress gradually decreases owing to softening of metal being heated. Compressive residual stress near the faying surfaces eventually reduces to zero as soon as melting starts and a reverse trend is observed during cooling stage of the welding. During cooling as metal starts to shrink, tensile residual stresses develop (only if shrinkage is not allowed either due to metallic continuity or constraint from job clamping) and their magnitude keeps on increasing until room temperature is attained. In general, greater is degree of constraint and elastic lami of melt higher will be the value of residual stresses.

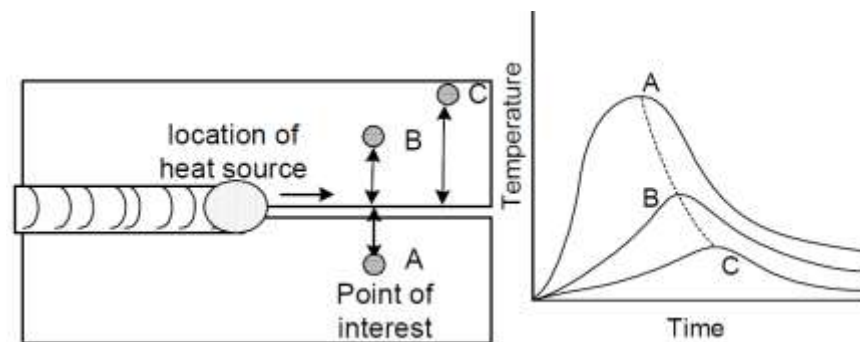


Fig. 71 weld thermal cycle of a) locations A, B, C and b) temperature vs time relation of A, B and C

Mechanisms of residual stress development

The residual stresses in the weld joints develop mainly due to typical nature of welding process i.e. localized heating and cooling leading to differential volumetric expansion and contraction of metal around the weld zone. The differential volumetric change occurs both at macroscopic and microscopic level. Macroscopic volumetric changes occurring during welding contribute to major part of residual stress development and are caused by a) varying expansion and contraction and b) different cooling rate experienced by top and bottom surfaces of weld & HAZ.

Microscopic volumetric changes mainly occur due to metallurgical transformation (austenite to martensitic transformation) during cooling. Further, it is important to note that whenever residual stresses develop beyond the yield point limit, the plastic deformation sets in the component. If the residual stress magnitude is below the elastic limit then a stress system having both tensile and compressive stresses for equilibrium is developed.

Differential heating and cooling

Residual stresses develop due to varying heating and cooling rate in different zones near the weld as function of time are called thermal stresses. Different temperature conditions lead to varying strength and volumetric changes in base metal during welding. The variation in temperature and residual stresses owing to movement of heat source along the centerline of weldment is shown schematically in Fig. 72. As heat source comes close to the point of interest, its temperature increases. Increase in temperature decreases the yield strength of material and simultaneously tends to cause thermal expansion of the metal being heated. However, surrounding low temperature base metal restricts any thermal expansion which in turn develops compressive strain in the metal during heating. Compressive strain initially increases non-linearly with increase in temperature due to variation in yield strength and expansion coefficient of metal with temperature rise. Further, increase in temperature softens the metal, therefore, compressive strain reduces gradually and eventually it is vanished. As the heat source crosses the point of interest and starts moving away from the point of interest, temperature begins to decrease gradually.

Reduction in temperature causes the shrinkage of hot metal in base metal and HAZ. Initially at high temperature contraction occurs without much resistance due to low yield strength of metal but subsequently shrinkage of metal is resisted as metal gains strength owing to reduction in temperature during cooling regime of weld thermal cycle (Fig. 73). Therefore, further contraction in shrinking base and weld metal is not allowed with reduction in temperature. This behavior of contraction leaves the metal in strained condition which means that metal which should have contracted, is not allowed to do so and this leads to development of the tensile residual stresses (if the contraction is prevented). The magnitude of residual stresses can be calculated from the product of locked-in strain and modulus of elasticity of metal being welded.

The residual stress along the weld is generally tensile in nature while balancing compressive residual stress is developed adjacent to the weld in heat affected zone on cooling to the room temperature as evident from the Fig. 72 (b).

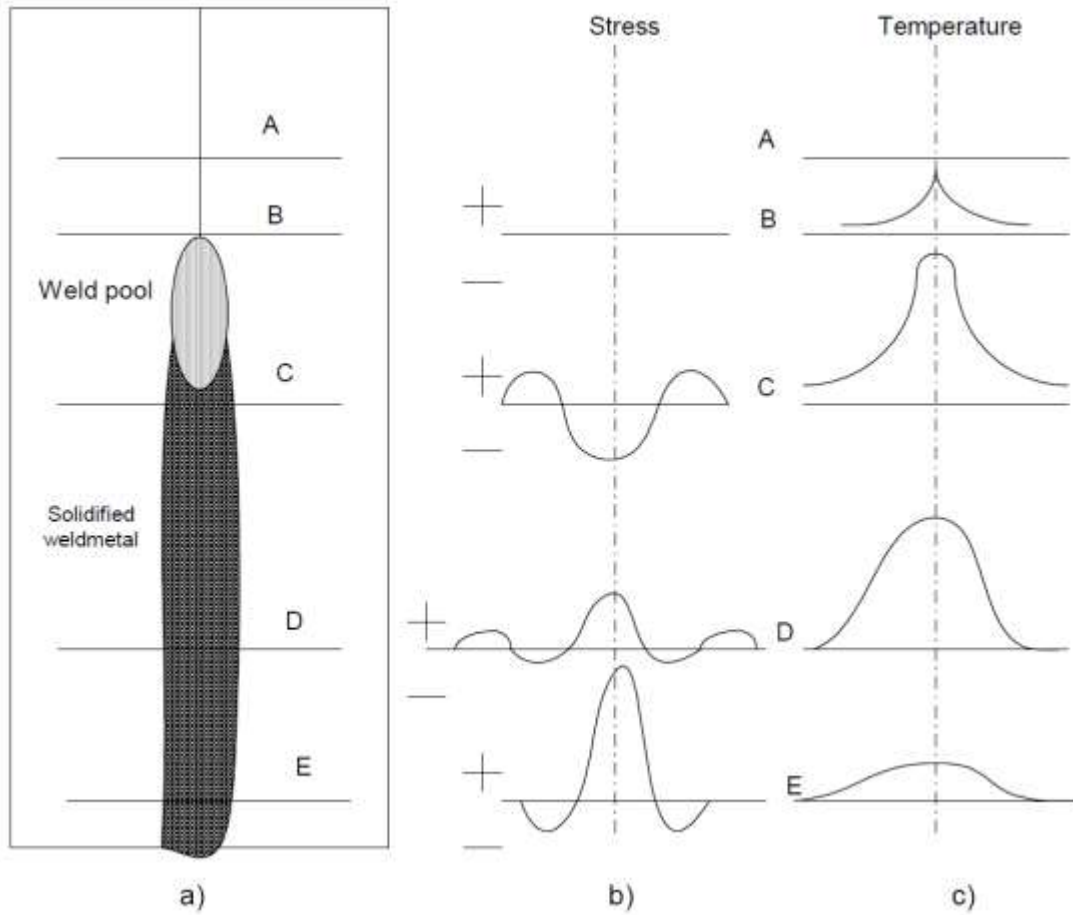


Fig. 72 Schematic diagram showing a) plate being welded, b) stress variation across the weld centerline at different locations and c) temperature of different locations

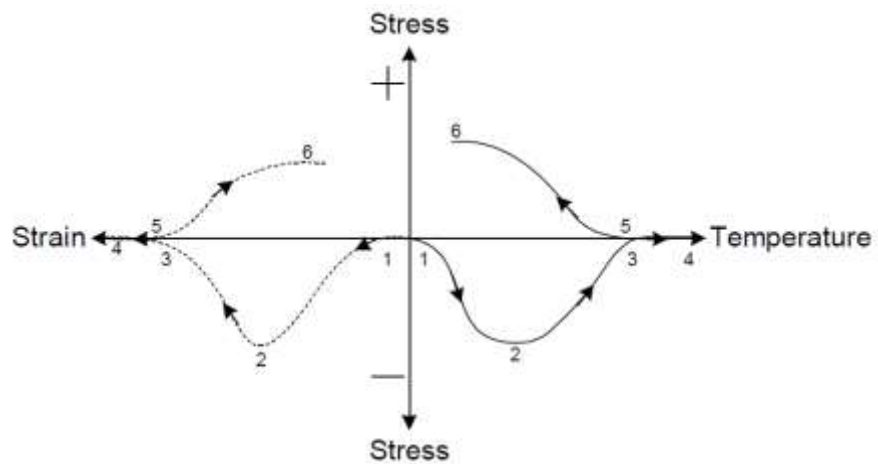


Fig. 73 Effect of temperature on variation in stress and strain during welding

Differential cooling rate in different zone

During welding, higher cooling rate is experienced by the top and bottom surfaces of weld joint than the core/middle portion of weld and HAZ (Fig. 74). This causes differential expansion and contraction through the thickness (direction) of the plate being welded. Contraction of metal near the surface starts even when material in core portion is still hot. This leads to the development of compressive residual stresses at the surface and tensile residual stress in the core.

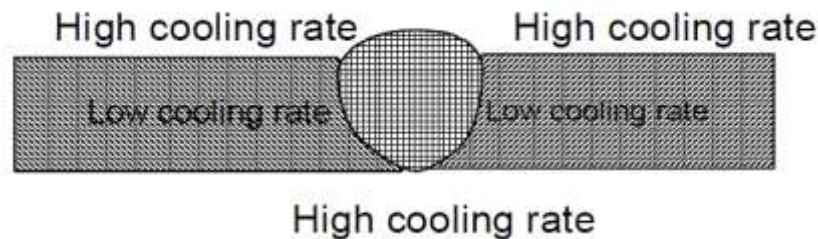


Fig. 74 Schematic showing different cooling rates at surface and core regions of the weld

Metallurgical Transformation

During welding, heat affected zone of steel and weld zone invariably experience transformation of austenite into other phases phase mixture like pearlite, bainite or martensite. All these transformations occur with increase in specific volume at microscopic level. The transformations (from austenite to pearlite and bainite) occurring at high temperature are easily accommodated with this increase in specific volume owing to low yield strength and high ductility of these phases and phase mixtures at high temperature (above 550 0C) therefore such metallurgical transformations don't contribute much towards the development of residual stresses.

Transformation of austenite into martensite takes place at very low temperature with significant increase in specific volume. Hence, this transformation contributes significantly towards development of residual stresses. Depending upon the location of the austenite to martensitic transformation, residual stresses may be tensile or compressive. For example, shallow hardening causes such transformation from

austenite to martensite near the surface layers only and develops compressive residual stresses at the surface and balancing tensile stress in core while through section hardening develops reverse trend of residual stresses i.e. tensile residual stresses at the surface and compressive stress in the core.

Effect of residual stresses

The residual stresses whether they are tensile or compressive type predominantly affect the soundness, dimensional stability and mechanical performance of the weld joints. Since magnitude of residual stresses increases gradually to peak value until weld joint is cooled down to the room temperature therefore mostly the effects of residual stresses are observed either near the last stage of welding or after some time of welding in the form of cracks (hot cracking, lamellar tearing, cold cracking), distortion and reduction in mechanical performance of the weld joint (Fig. 75).

Presence of residual stresses in the weld joints can encourage or discourage failures due to external loading as their effect is additive in nature. Conversely, compressive residual stresses decrease failure tendency under external tensile stresses primarily due to reduction in net tensile stresses acting on the component (net stress on the component: external stresses + residual stresses). Residual stress of the same type as that of external one increases the failure tendency while opposite type of stresses (residual stress and externally applied stress) decrease the same.

Since more than 90% failure of mechanical component occurs under tensile stresses by crack nucleation and their propagation under tensile loading conditions therefore presence of tensile residual stresses in combination with external tensile loading adversely affect the performance in respect of tensile load carrying capacity while compressive residual stresses under similar loading conditions reduce the net stresses and so discourage the failure tendency.

Hence, compressive residual stresses are intentionally induced to enhance tensile and fatigue performance of mechanical components whereas efforts are made to reduce

tensile residual stresses using various approaches such as post weld heat treatment, shot peening, spot heating etc.

In addition to the cracking of the weld joint under normal ambient conditions, failure of weld joints exposed in corrosion environment is also accelerated in presence of tensile residual stresses by a phenomenon called stress corrosion cracking.

Presence of tensile residual stresses in weld joints causes cracking problems which in turn adversely affect their load carrying capacity. The system residual stress is usually destabilized during machining and may lead to distortion of the weld joints. Therefore, residual stresses must be relieved from the weld joint before undertaking any machining operation.

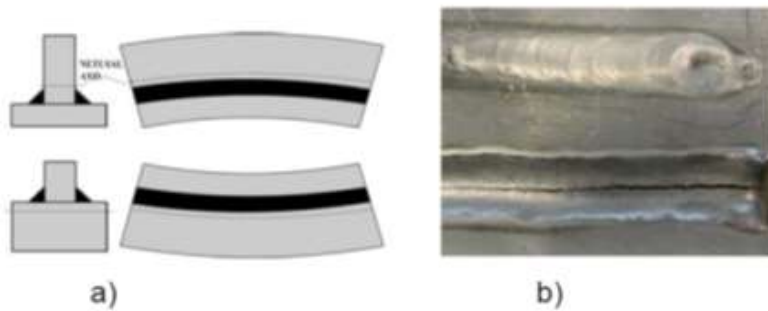


Fig 75 Typical problems associated with residual stress a) distortion and b) solidification cracking

Controlling the residual stresses

The critical applications frequently demands relieving residual stresses of weld joints by thermal or mechanical methods. Relieving of residual stresses is primarily based on releasing the locked-in strain by developing conditions to facilitate plastic flow so as to relieve stresses.

- (a) *Thermal method* is based on the fact that the yield strength and hardness of the metals decrease with increase of temperature which in turn facilitates the release of locked in strain thus relieves residual stresses. Reduction in residual stresses depends on "how far reduction in yield strength and hardness take place with increase of temperature". Greater is the softening more will be the relieving of residual stresses. Therefore, in general, higher is the temperature of thermal treatment of the weld joint greater will be reduction in residual stresses.
- (b) *Mechanical method* is based on the principle of relieving residual stresses by applying external load beyond yield strength level to cause plastic deformation so as to release locked-in strain. External load is applied in an area which is expected to have peak residual stresses.
- (c) *Mechanical Vibration* : The vibrations of a frequency close to natural frequency of welded joint is applied on the component to be stress relieved. The vibratory stress can be applied in whole of the components or in localized manner using pulsators. The development of resonance state of mechanical vibrations on the welded joints helps to release the locked in strains so to reduce residual stresses.

15.6 Weld Distortion

Weld distortions due to solidification shrinkage and thermal contraction of the weld metal during welding.

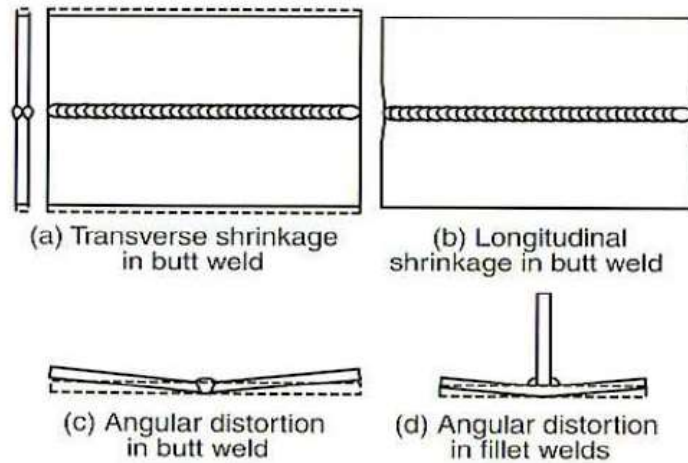


Fig 76: Distortion in welded structure

Angular distortion

Upward angular distortion usually occurs when the weld is made from the top of the workpiece alone. The weld tends to be wider at the top than the bottom, causing more solidification shrinkage and thermal contraction.

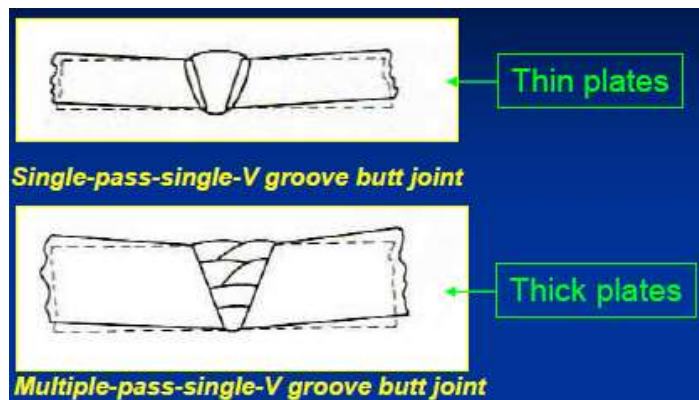


Fig 77: Angular Distortions in butt welded plates

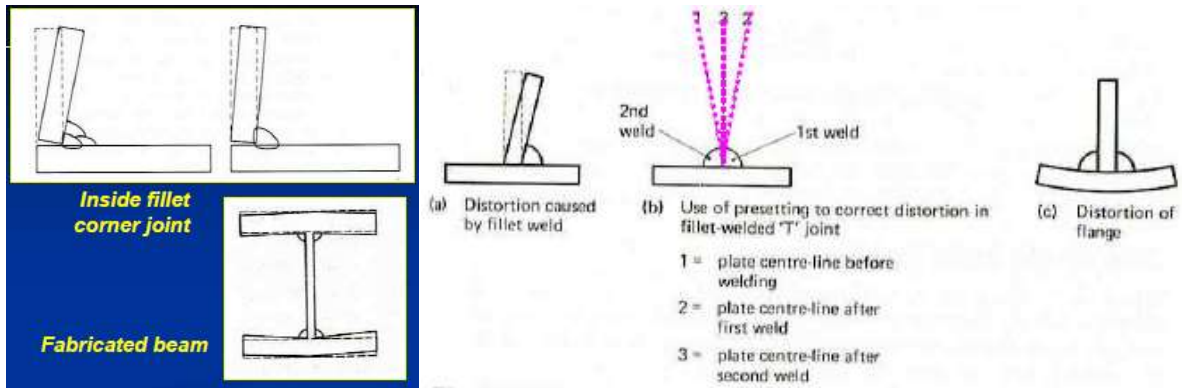


Fig 78: Angular Distortions in fillet joint

Remedies for angular distortion

There are several techniques used to reduce angular distortion.

- Reducing volume of weld metal
- Using double-V joint and alternate welding
- Placing welds around neutral axis
- Controlling weld distortion

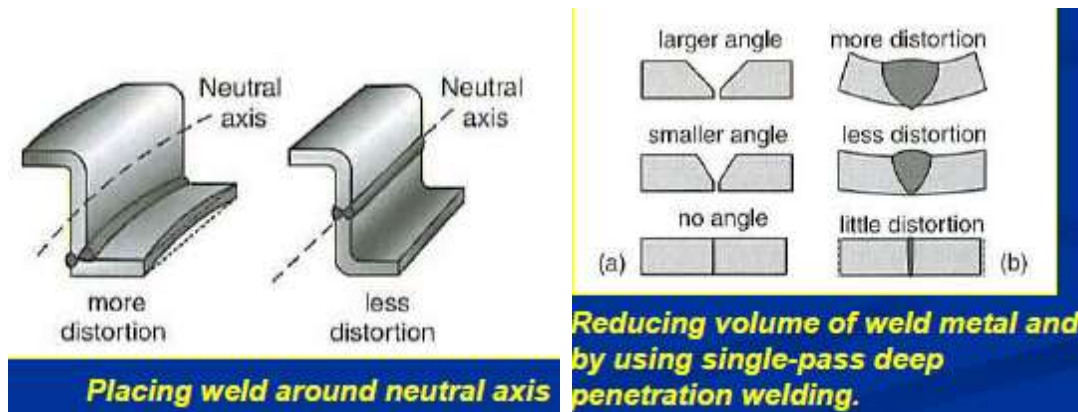


Fig 79: Angular Distortions prevention techniques

Balancing the angular weld distortion on either side of the double V joint

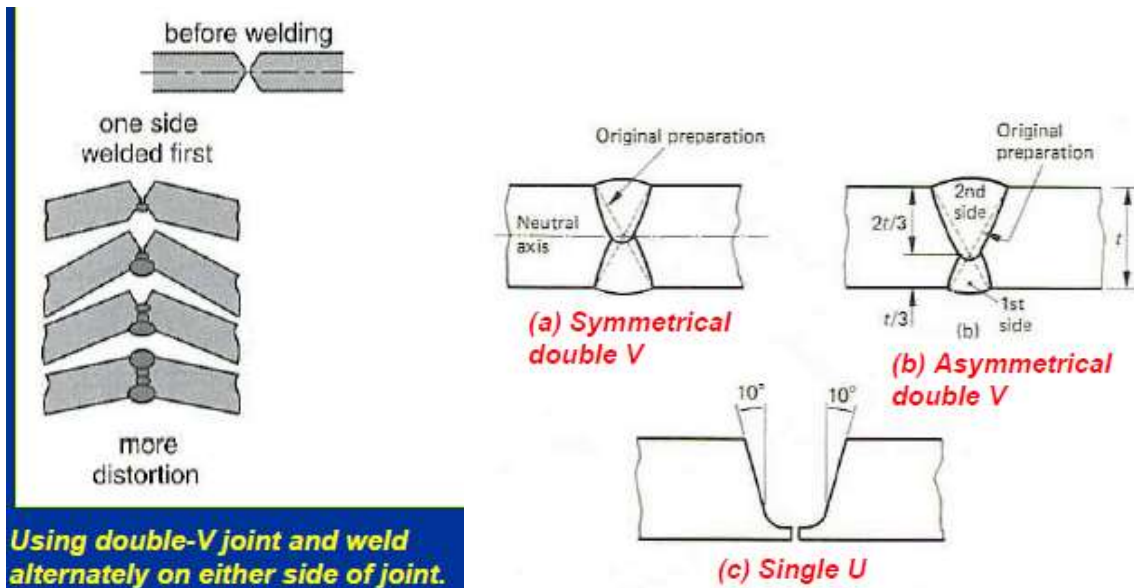


Fig 80: Angular Distortions prevention for different grooves

- Double V-joints balance the shrinkage _ almost same amount of contraction on each side (a).
- Asymmetrical double V: The first weld always produces more angular distortion _ the second side is larger too pull back the distortion when the first weld is made (b).
- A single U joint gives a uniform weld with through the section (c).

Methods for controlling weld distortion:

- Presetting
- Springing
- Preheating

- Presetting: by compensating the amount of distortion to occur in welding.
- Elastic prespringing can reduce angular changes after restraint is removed.
- Preheating and post weld treatment

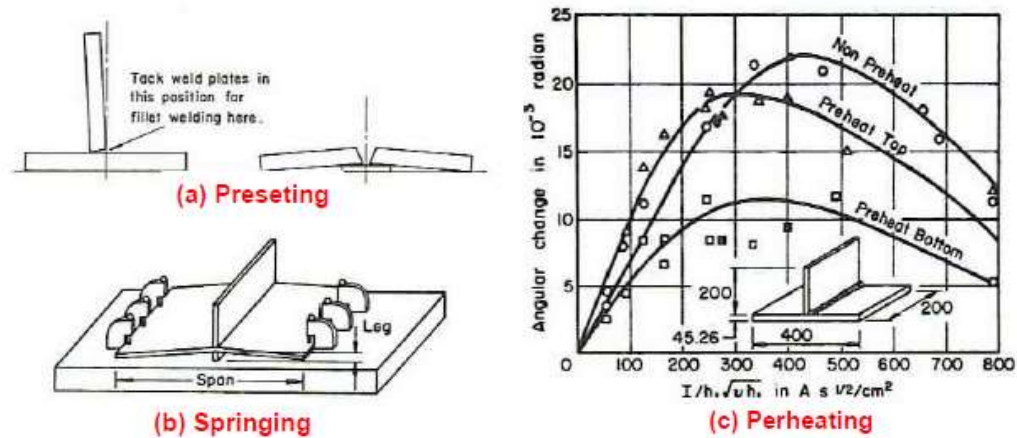


Fig: 81a Methods for controlling weld distortion

Longitudinal distortion

- Heating and cooling cycles along the joint during welding build up a cumulative effect of longitudinal bowing.

Remedies

- Welding short lengths on a planned or random distribution are used to controlled this problem.
- Mechanical methods: straightening press, jacks, clamps
- Thermal methods: local heating to relieve stresses (using torches) but cannot be used for highly conductive metal such as Al and Cu.

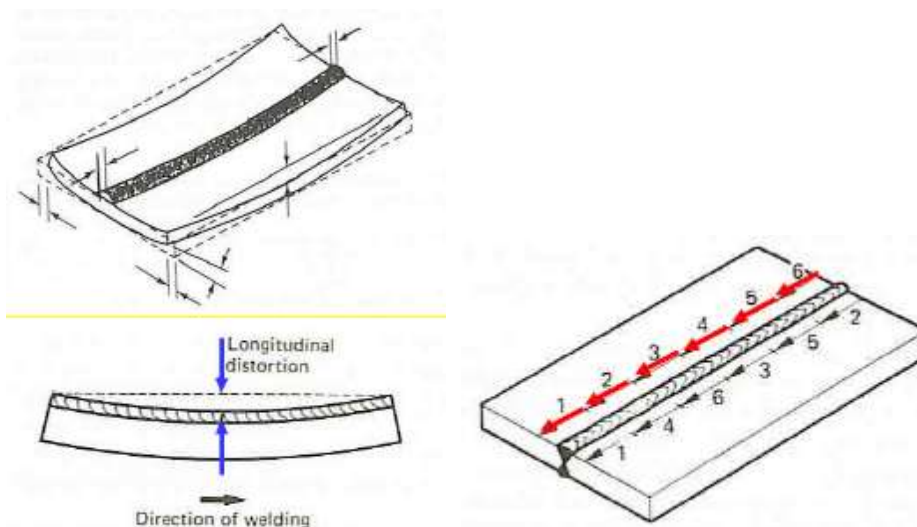


Fig: 81b Methods for controlling weld distortion

Sequences for welding short lengths of a joint to reduce longitudinal bowing

- Angular distortion and longitudinal bowing can also be observed in joints made with fillet welds such as fillet-welded T joint

Remedies

- Back-step technique is also used. Each small increment will have its own shrinkage pattern which then becomes insignificant to the whole pattern of weldment. (But time consuming)
- Using the smallest possible weld size.

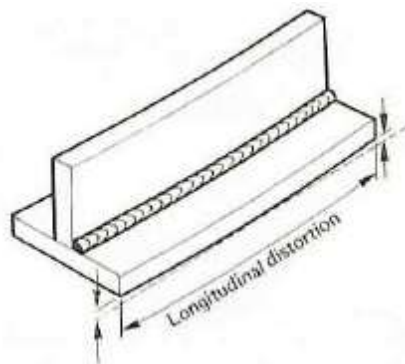


Fig: 81c Longitudinal bowing in a fillet welded T joint

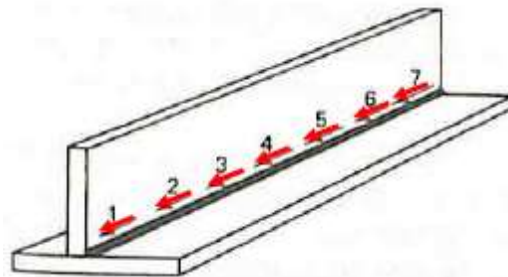


Fig: 81d Back step technique

Module-IV

Analysis of fatigue of welded joint, fracture and toughness testing and its application on welded joint, automated welded joint, microprocessor based of control resistance and arc welding, quality assurance in welding, effects of welding fumes on environment.

16. Fatigue analysis of welded joints

Fatigue of welds is even more complex. Welding strongly affects the material by the process of heating and subsequent cooling as well as by the fusion process with additional filler material, resulting in inhomogeneous and different materials. Furthermore, a weld is usually far from being perfect, containing inclusions, pores, cavities, undercuts etc. The shape of the weld profile and non-welded root gaps create high stress concentrations with widely varying geometry parameters. Last but not least residual stresses and distortions due to the welding process affect the fatigue behaviour. As a consequence, fatigue failures appear in welded structures mostly at the welds rather than in the base metal, even if the latter contains notches such as openings or re-entrant corners. For this reason, fatigue analyses are of high practical interest for all cyclic loaded welded structures, such as ships, offshore structures, cranes, bridges, vehicles, railcars etc. In view of the complexity of the subject and the wide area of application it is not surprising that several approaches for fatigue analysis of welded joints exist. However, it is almost impossible to follow up the great amount of related literature dealing with fatigue testing and the development or application of approaches to consider all the different influence parameters.

16.1 *Fatigue analysis approaches*

Different approaches exist for the fatigue analysis of welded joints, which can be distinguished by the parameters used for the description of the fatigue life N or fatigue strength. In general, the approaches can be subdivided into the following categories:

- * Nominal stress approach, using the nominal stress range determined by the external or internal loads and by the related cross section properties.
- * Structural or hot-spot stress approach, using the structural stress range at the weld to consider additionally the effect of the structural discontinuity.

Notch stress and notch intensity approach, using the elastic notch stress range or an equivalent parameter such as the stress intensity to take the notch effect of the weld toe or root into account.

* Notch strain approach, using the local elastic–plastic strain range and/or other parameters describing the relevant damage process in the material.

* Crack propagation approach, using special parameters such as the J-integral or the range of the stress intensity to describe the increase of the crack length per cycle, i.e. the crack propagation rate.

To produce quality weld joints, it is necessary to keep an eye on what is being done in three different stages of the welding

- Before welding such as cleaning, edge preparation, baking of electrode etc. to ensure sound and defect free weld joints.
- During welding various aspects such as manipulation of heat source, selection of input parameters (pressure of oxygen and fuel gas, welding current, arc voltage, welding speed, shielding gases and electrode selection) affecting the heat input and so melting, solidification and cooling rates besides protection of the weld pool from atmospheric contamination.
- After welding steps, if any, such as removal of the slag, peening, post welding treatment

Selection of optimal method and parameters of each of above steps and their execution meticulously in different stages of production of a weld joint determine the quality of the weld joint. Inspection is mainly carried out to assess ground realities in respect of progress of the work or how meticulously things are being implemented. Testing helps to: a) assess the suitability of the weld joint for a particular application and b) to take decision on whether to go ahead (with further processing or accept/reject the same) at any stage of welding and c) quantify the performance parameters related with soundness and performance of weld joints.

Testing methods of the weld joint are broadly classified as destructive testing and non-destructive testing. Destructive testing methods damage the test piece to more or less extent. The extent of damage on (destructive) tested specimens sometime can be up to complete fracture (like in tensile or fatigue testing) thus making it un-useable for the intended purpose while in case of non-destructive tested specimen the extent of damage on tested specimen is either none or negligible which does not adversely affect their usability for the intended purpose in anyways.

Weld joints are generally subjected to destructive tests such as hardness, toughness, bend and tensile test for developing the welding procedure specification and assessing the suitability of weld joint for a particular application.

Visual inspection reflects the quality of external features of a weld joint such as weld bead profile indicating weld width and reinforcement, bead angle and external defects such as craters, cracks, distortion etc. only.

16.2 Destructive Test

Tensile test

Tensile properties of the weld joints namely yield and ultimate strength and ductility (%age elongation, %age reduction in area) can be obtained either in ambient condition or in special environment (low temperature, high temperature, corrosion etc.) depending upon the requirement of the application using tensile test which is usually conducted at constant strain rate (ranging from 0.0001 to 10000 mm/min). Tensile properties of the weld joint are obtained in two ways a) taking specimen from transverse direction of weld joint consisting base metal heat-affected zone-weld metal-heat affected zone-base metal and b) all weld metal specimen as shown in Fig. 82 (a, b).

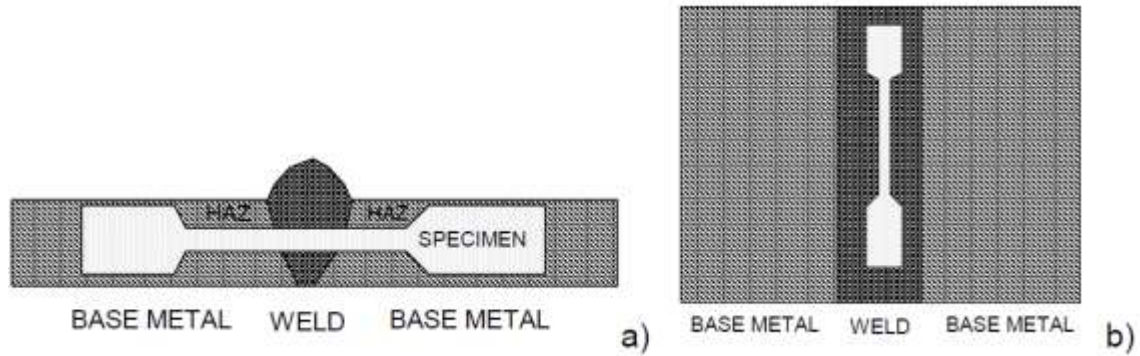


Fig. 82 Schematic of tensile specimens from a) transverse section of weld joints and b) all weld specimen

Tensile test results must be supported by respective engineering stress and strain diagram indicating modulus of elasticity, elongation at fracture, yield and ultimate strength (Fig. 83). Tests results must include information on following point about test conditions

- Type of sample (transverse weld, all weld specimen)
- Strain rate (mm/min)
- Temperature or any other environment in which test was conducted if any
- Topography, morphology, texture of the fracture surface indicating the mode of fracture and respective stress state

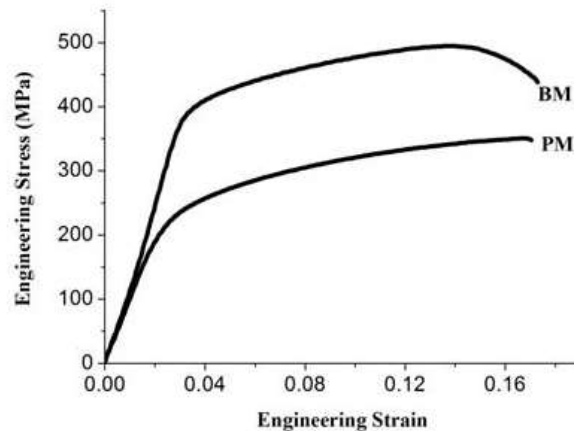


Fig. 83 Typical stress strain diagram for AA 7039 in as received (BM) and friction stir processed (PM) condition

Bend test

Bend test is one of the most important and commonly used destructive tests to determine the ductility and soundness (for the presence porosity, inclusion, penetration and other macro-size internal weld discontinuities) of the weld joint produced using under one set of welding conditions. Bending of the weld joint can be done from face or root side depending upon the purpose i.e. whether face or root side of the weld is to be assessed. The root side bending shows the lack of penetration and fusion if any at the root. Further, bending can be performed using simple compressive/bending load and die of standard size for free and guided bending respectively (Fig. 84, 85). Moreover, free bending can be face or root bending while guided bending is performed by placing the weld joint over the die as needs for bending is better and controlled condition as shown in Fig. 84.



Fig. 84 Schematics of free bend tests

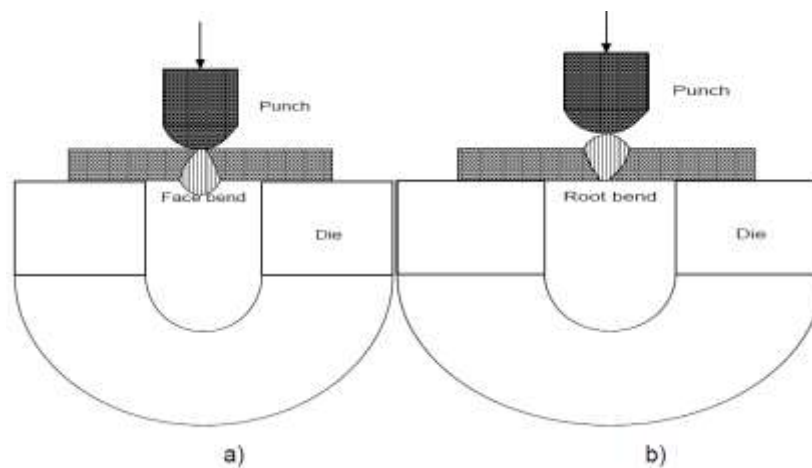


Fig. 85 Schematics of guided bend tests a) face bend and b) root bend

For bend test, the load increased until cracks start to appear on face or root of the weld for face and root bend test respectively and angle of bend at this stage is used as a measure of ductility of weld joints. Higher is bend angle (needed for crack initiation) greater is ductility of the weld. Fracture surface of the joint from the face/root side due to bending reveals the presence of internal weld discontinuities if any.

Hardness test

Hardness is defined as resistance to indentation and is commonly used as a measure of resistance to abrasion or scratching. For the formation of a scratch or causing abrasion, a relative movement is required between two bodies and out of two one body must penetrate/indent into other body. Indentation is the penetration of a pointed object (harder) into other object (softer) under the external load. Resistance to the penetration of pointed object (indenter) into the softer one depends on the hardness of the sample on which load is applied through the indenter.

All methods of hardness testing are based on the principle of applying the standard load through the indenter (a pointed object) and measuring the penetration in terms of diameter/diagonal/depth of indentation (Fig. 86). High penetration of an indenter at a given standard load suggests low hardness. Various methods of hardness testing can be compared on the basis of following three criteria 1) type of indenter, 2) magnitude of load and 3) measurement of indentation.

Parameter	Brinell	Rockwell	Knoop	Vickers
Load	500-2000 kg	Minor: 10 kg Major: 60 to 200 kg as dictated by scale to be used (A-C)	10 to 3000 g	
Indenter	Ball	Ball or cone	Cone	Pyramid
Measurement	Diameter	Depth	Diagonal	Diagonal

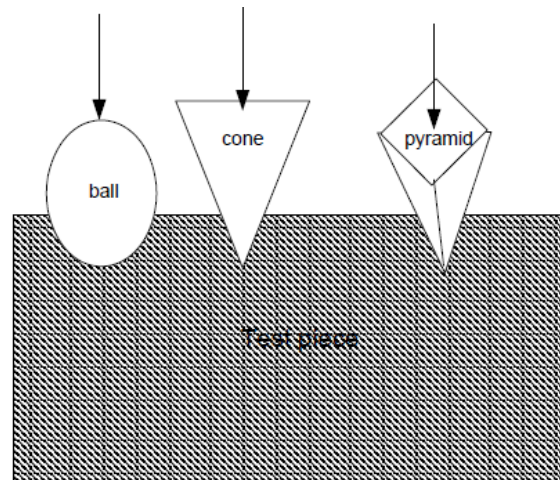


Fig. 86 Schematic diagram showing indentation using different indenters corresponding to different hardness test methods

Penetration due to applied normal load is affected by unevenness on the surface and presence of hard surface films such as oxides, lubricants, dust and dirt etc. if any. Therefore, surface should be cleaned and polished before hardness test. In case of Brinell hardness test, full load is applied directly for causing indentation for measuring hardness while in case of Rockwell hardness test, minor load (10 kN) is applied first before applying major load. Minor load is applied to ensure the firm metallic contact between the indenter and sample surface by breaking surface films and impurities if any present on the surface. Minor load does not cause indentation. Indentation is caused by major load only. Therefore, cleaning and polishing of the surface films becomes mandatory for accuracy in hardness test results in case of Brinell test method as major load is applied directly. Steel ball of different diameters (D) is used as an indenter in Brinell hardness test. Diameter of indentation (d) is measured to calculate the projected area and determine the hardness. Brinell hardness test results are expressed in terms of pressure generated due to load (P). It is calculated by the ratio of load applied and projected contact area. Load in the range of 500 to 3000 kg can be applied depending upon the type of material to be tested. Higher load is applied for hardness testing of hard materials as compared to soft materials.

$$\text{BHN} = \frac{2P}{\pi D [D - (D^2 - d^2)^{1/2}]}$$

In case of Rockwell hardness test first minor load of 10 kg is applied and then major load of 50-150kg is applied on the surface of the work-piece through the indenter and the same is decided by scale (A, B, C and D) to be used as per type of material to be tested. Minor load is not changed. Out of mainly scales, B and C scales are commonly used. Different indenter and major load are required for each scale. Steel ball and diamond cone are two types of indenters used in Rockwell testing. B scale uses hardened steel ball and major load of 90kg whereas C scale uses diamond cone and major load of 140kg accordingly hardness is written in terms of HRB and HRC respectively.

Vickers hardness test uses square pyramid shape indenter of diamond and load ranging from 1 to 120 kg. Average length (L) of two diagonals of square indentation is used as a measure of hardness. Longer is average diagonal length lower is hardness. Vickers hardness number (VHN) or diamond pyramid hardness (DPH) is the ratio of load (P) and apparent area of indentation given by the relation:

$$DPH = \frac{1.854P}{L^2}$$

In actual practice, engineering components during service are invariably subjected to various kinds of loads namely static and dynamic loads which are classified on the basis of the rate of change in magnitude of load and direction.

Dynamic loads are characterized by high rate of change in load magnitude and direction. Reverse happens in case of static loads. In the hardness test and tensile tests, load is increased very slowly that corresponds to the behaviour of material under more or less static loading condition. Moreover, very wide range rate of loading (0.0001 to 1000mm/min) can be used in tensile test. Rate of loading governs the strain rate and so rate of hardening which can affect mechanical behavior of material. For example, material at low rate of loading showing the ductile behaviour can exhibit brittle behaviour under high rate of loading conditions.

The toughness test simulates service conditions often encountered by components of the system used in transportation, agricultural, and construction equipment. A material high impact resistance is said to be a tough material. Toughness is the ability of a material to resist both fracture and deformation. Toughness is the combination of strength and ductility.

must exhibit both fairly good strength and ductility to resist cracking and deformation under impact loading. Notches are made intentionally in impact test specimens to increase the stress concentration so as to increase tendency to fracture as most of the mechanical components have stress raisers. To withstand an impact force, a notched material must be tough.

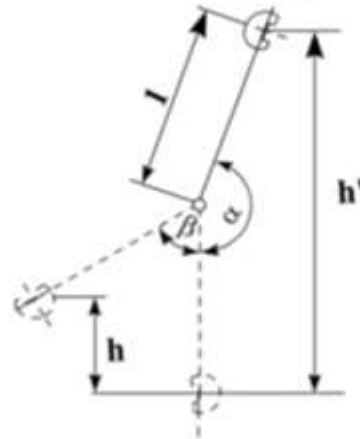


Fig 87 Principle diagram of toughness test.

To study the behaviour of material under dynamic load conditions (at high rate of loading) toughness test is frequently conducted. There are two methods used for toughness testing namely Izod and Charpy test, based on the common principle of applying the load at high rate and measuring the amount of energy absorbed (kg m or Joule) in breaking the sample due to impact (Fig. 32.1). However, there are some differences also in these two methods in terms of sample size and shape, method of holding of the sample and maximum energy content of pendulum that hits the sample during the test.

Sr. No.	Toughness test	Sample	Holding
1	Izod	Held vertically on anvil as cantilever	Cantilever type and notch faces the pendulum
2	Charpy	Held horizontally on anvil as simply supported beam	Simply supported type and notch is opposite side of pendulum impact (not facing to pendulum)

Standard sample for both testing methods having a notch and is mounted on the machine in specific ways i.e. notch faces to pendulum in case Izod test while pendulum hits the sample from back of the notch in Charpy test

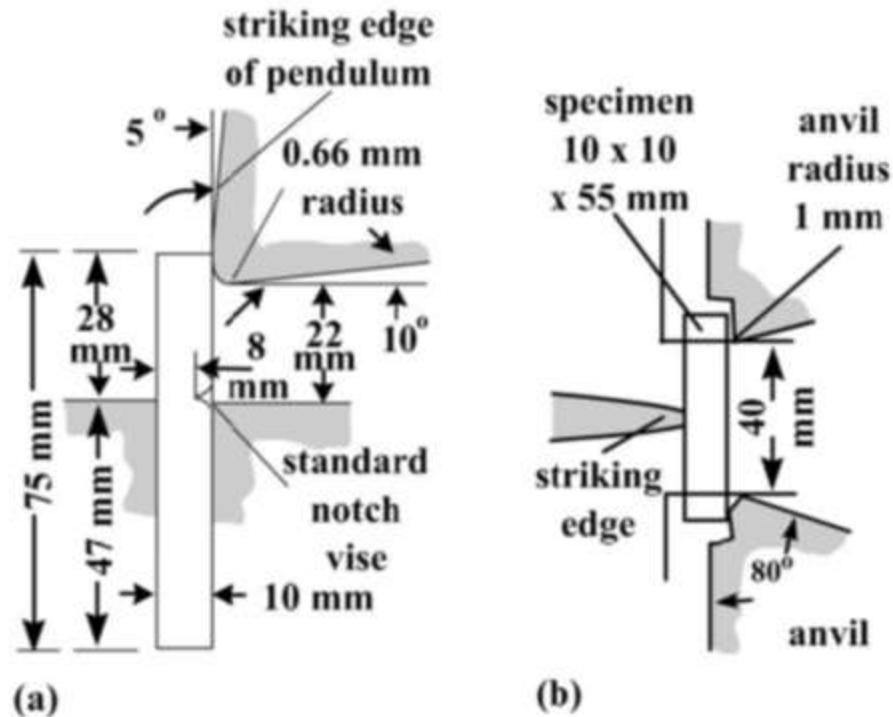


Fig 88 Standard specimens for a) izod and b) charpy impact test

Since most of the engineering components are invariably designed with notch and stress raisers therefore, it becomes important to know about the behaviour of material with notch under impact loading. Hence, toughness test is usually conducted using sample with notch. Moreover, un-notched samples can also be used for the toughness test and the results are expressed accordingly.

Results of impact tests are expressed in terms of either amount of energy absorbed (Nm) or amount of energy absorbed per unit cross sectional area (Nm/cm^2) by standard sample. It may be noted that values of toughness are not directly used for design purpose but these only indicate the ability of the material to withstand against shock/impact load i.e. load applied at very high rate. These tests are useful for comparing the resistance to impact loading of different materials or the same material in different processing conditions such as heat treatment, procedure and mechanical

working etc. Resistance to the impact loading of a material appreciably depends on the surrounding temperature (Fig. 89). Therefore, temperature at which toughness test is conducted must be reported with results.

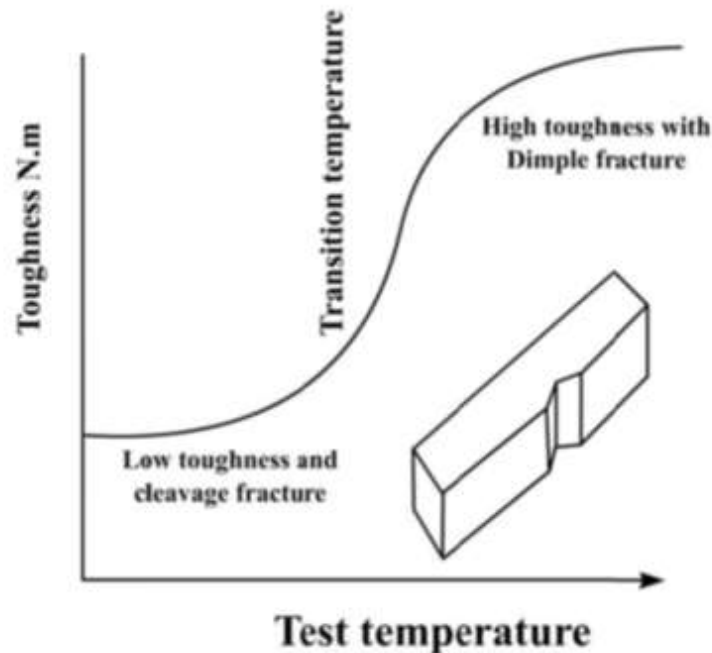


Fig. 89 Schematic diagram showing influence of test temperature on toughness

Fatigue behaviour of weld joint

The fatigue performance of the metallic components in general is determined in two ways a) endurance limit i.e. indicating the maximum stress, stress amplitude or stress range for infinite life (typically more than 20 million of load cycles) and b) number of load cycle a joint can be withstand for a set of loading conditions as desired. Two types of samples are generally prepared for fatigue studies as per ASTM 466 (Fig. 90 a, b). Reduced radius sample generally ensures fracture from weld joint or any specific location of interest (Fig. 90 a, b). The fatigue performance is appreciably influenced by the various variable related with fatigue test namely stress ratio, type of stress (tension-tension, reverse bending, tension-compression, zero-tension), maximum stress, stress range, loading frequency and surrounding environmental conditions such as temperature, corrosion, vacuum, tribological conditions. Each and every parameter to be used for the fatigue test must be carefully selected and recorded with results while reporting. The fatigue test results should include following.

- Test conducted according to ASTM E466 standard
- Type of loading: axial pulsating/reverse bending/tension-compression
- Maximum stress:
- Stress ratio (ratio of minimum stress to maximum stress)
- Temperature: ambient/vacuum/corrosion
- Frequency of pulsating load: load cycles per min
- Type of sample

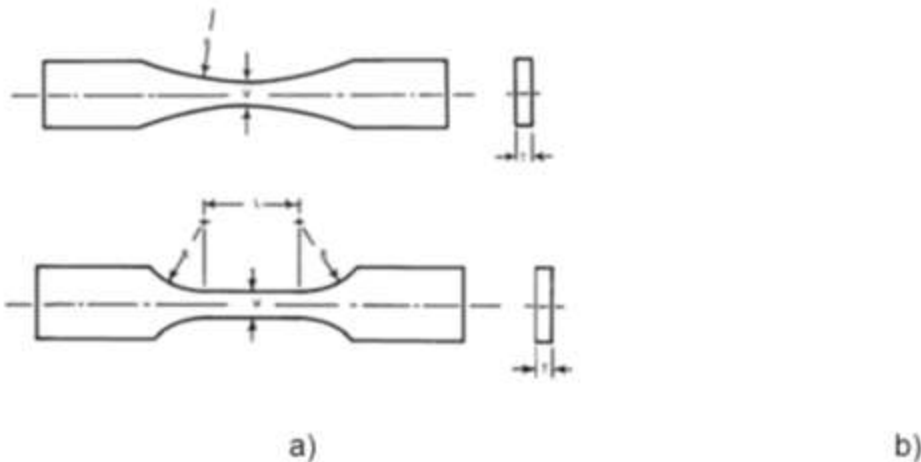
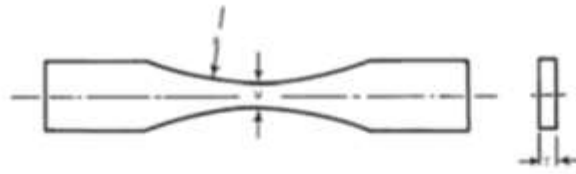


Fig 90 Standard specimen for fatigue testing

To conducting fatigue test, first step is conduct the tensile test on the weld joint for establishing the yielding strength of metal as maximum stress becomes 0.9 times of yield strength of material. For plotting the stress-number of cycle (S-N) curve, fatigue test is first conducted with maximum applied tensile load corresponding to 0.9 times of yield strength of weld joint under study to determine the number of load cycle required for fracture and then in the same way test is repeated at 0.85, 0.8, 0.75, 0.7 times of yield strength of weld joint until endurance limits or desired fatigue life is not achieved

Typical dimensions of a standard specimen as per ASTM 466 are as-under.

- Continuous radius (R): 100mm
- Width (W): 10.3mm
- Thickness *T): 11mm (as received)
- Gripping length: 50mm



a)



b)

FIG 91 Fatigue test sample a) Schematic diagram of standard fatigue test sample with continuous radius between ends and b) photograph of typical specimen

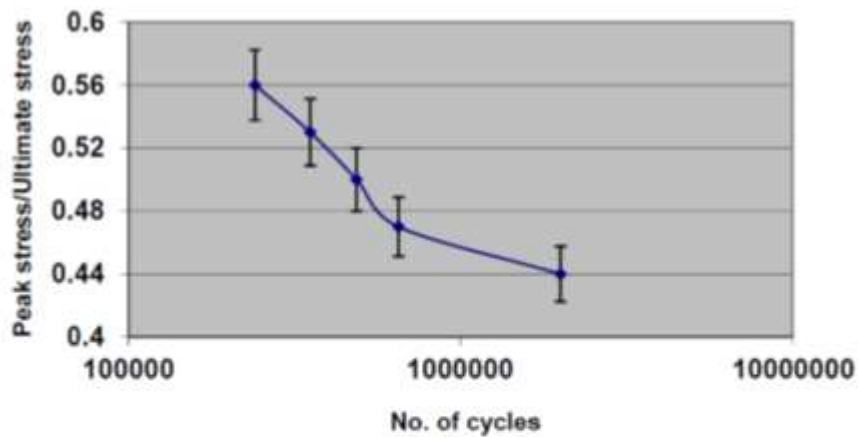


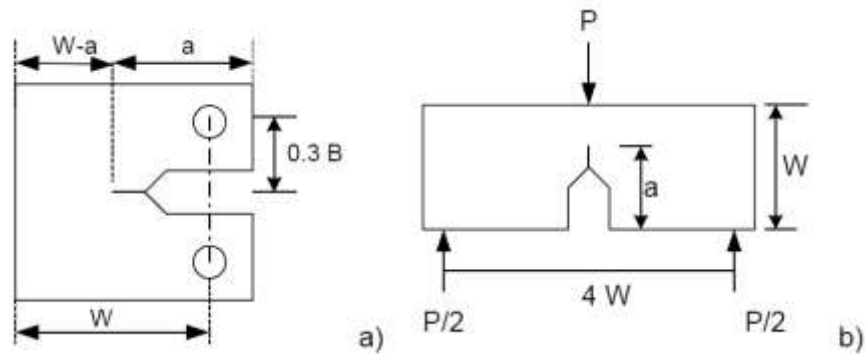
Fig 92 Typical data on fatigue test showing peak stress/ultimate stress vs. number of cycle relationship for structure steel

Fracture toughness

The resistance to fracture conversely resistance to crack growth is known as fracture toughness and is measured using various parameters such as a) stress intensity around

the crack tip (K), opening of crack mouth also called crack tip opening displacement (CTOD) and energy requirement for growth of crack (J or G). The mechanical properties namely yield strength and ductility and thickness of the weld joint under study primarily dictate the suitable parameter to be used for determining the fracture toughness. The fracture toughness parameter namely stress intensity factor (K) is commonly used for weld joint of heavy sections of high strength and low ductility material developing plain strain conditions, while crack tip opening displacement and energy based methods (G and J integral) are used for comparatively thinner sections made of low strength and high ductility material and those develop plain stress condition under external loading.

Measurement of fracture toughness using any of above parameters is performed using two types of samples a) compact tension specimen (CT) and b) three point bending specimen (TPB). Schematics of two type of specimen are shown in Fig. 93. In general, in these tests, applied external load is increased until strain/crack opening displacement/energy vs. load relationship becomes non-linear. This critical value of load (P) is used for calculations of fracture toughness using relevant formulas.



$W=2B$, $a=B$, $W-a=B$ and radius of hole $r = 0.25B$ where B is plate thickness

Fig. 93 Schematic of fracture toughness specimens using a) compact tension and b) three point bending approaches

Although different standards have historically been published for determining K , CTOD and J -integral, the tests are very similar, and generally all three values can be established from one type of test. In general, stress intensity factor (K) decreases with increase in specimen thickness. This trend continues up to a limit of thickness thereafter

K becomes independent of the plate thickness. The corresponding value of K is called critical stress intensity factor (K_{Ic}) and occurs in *plane strain condition*. K_{Ic} is used for the estimation of the critical stress need to apply to a specimen with a given crack length for catastrophic fracture to take place.

$$\sigma_C \leq K_{Ic} / (Y(\pi a)^{1/2})$$

Where K_{Ic} is the stress-intensity factor, measured in $\text{MPa}\cdot\text{m}^{1/2}$, σ_C is the critical stress applied to the specimen, a is the crack length for edge crack or half crack length for internal crack and Y is a geometry factor.

16.3 Non-destructive testing (NDT)

To determine the presence of surface and surface imperfections, non-destructive testing of weld joints can be carried out using variety of techniques as per needs. Apart from the visual inspection, many non-destructive testing methods including dye penetrant test (DPT), magnetic particle test (MPT), eddy current test (ECT), ultrasonic test (UT), radiographic test (RT) etc. are used in manufacturing industry for assessing the soundness of weld joints. In following section, principle and capability of some nondestructive testing methods have been described.

Dye penetrant test

This is one of the simplest non-destructive testing methods primarily used for detecting the presence of surface defects only. In this method surface to be tested a thin low viscosity and low surface tension liquid containing suitable dye is applied (Fig. 94). The thin liquid penetrates (by capillary action) into fine cavities, pores and cracks, if any, present on the surface. Excess liquid present at surface is wiped out. Then suitable developer like talc or chalk powder is sprinkled over the surface. Developer sucks out thin liquid with dye wherever it is present inside the surface discontinuities present on the weld joints. Dye with liquid changes colour of developer and indicates location, and size of surface defects.

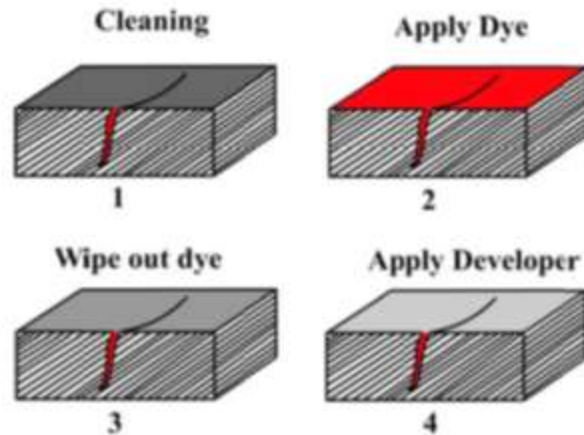


Fig 94 Schematic showing four steps of dye penetrant test

Magnetic particle testing

This method is mainly used for assessing the surface and near surface defects in magnetic material. It is based on the simple principle of the flow of magnetic line of forces. Magnetic flux flows easily through metal from south to north-pole. The component to be evaluated is magnetized using electrical energy or suitable permanent magnetic. The electro-magnetization is performed using suitable yoke which is applied across the location / area to be tested. Presence of any dis-continuity in the form of crack, porosity, near surface defects in the path of flow of these lines results in leakage of magnetic flux forming two additional poles. The magnetic powder particles (in dry form or suspension form in thin liquid) are sprinkled over the surface of components to be tested. The magnetic particles tend to migrate toward the location wherever leakage of magnetic flux had taken place and then get piled up (Fig. 94). The particles align along discontinuities on the surface, near or shallow sub-surface discontinuities. The location and pattern of piled up magnetic powder particles suggest the location, size, type of discontinuity present on the surface or near surface region. Hazy pile of powder particle indicates the sub-surface defect. Formation of very thin line of powder particles suggests presence of crack with details of size and location of crack. However, this method of testing is found fit for ferromagnetic metal only.

metal being tested, ultrasonic vibrations are reflected so they don't reach up to the receiving end and so no signal is received. Under this condition, only one peak is observed in the oscilloscope and absence of another peak from bottom surface suggests presence of discontinuity in the metal tested. One by one entire surface area of the component to be tested is scanned using transmitting and receiving probes. However, transmission approach is not very useful due to two reasons a) requirement of access to both sides of component to be tested and b) difficulty in placement of receiving probe in line of transmitting probe sending ultrasonic vibrations especially in case of components having thick sections.

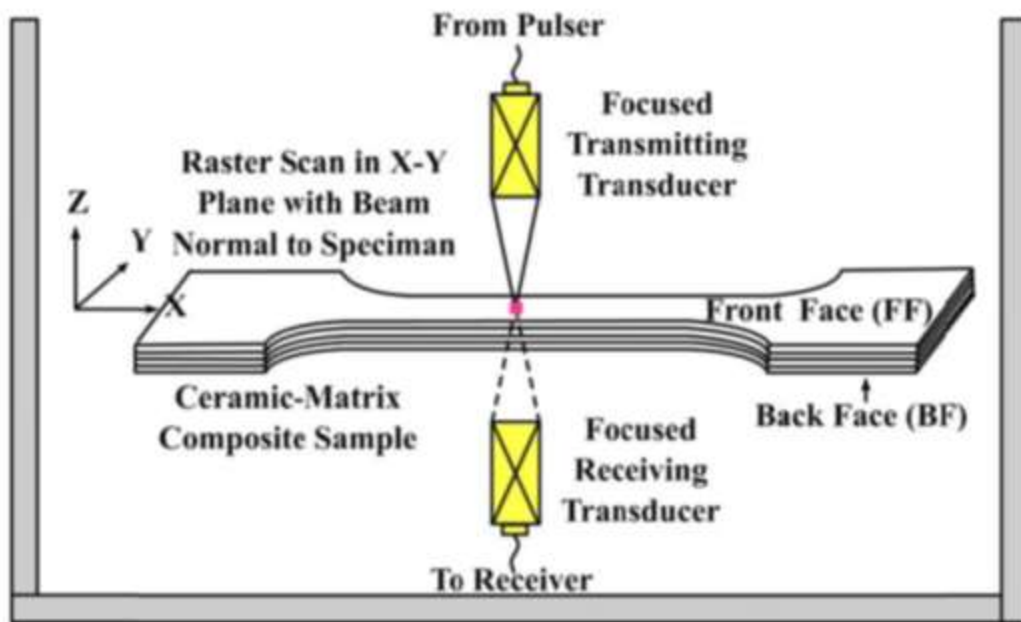


Fig 96 Transmission type of ultrasonic testing

17. Microprocessor-Based Electrode Movement Controller

In normal practice, the welding current, pressure applied to the workpiece, and weld time are all preset for a particular application depending upon the material properties of the workpiece to be welded, and upon the electrode tip geometry. Satisfactory machine settings will guarantee a good weld quality of the workpiece. However, even when the machine variables are held constant, there is considerable variation in the weld quality

from part to part. This is due to variation in the welding current which is caused by changes in the surface condition of the workpiece, changes in the electrode tip diameter fit-up, and changes in the impedance of the welding circuit. The shunting effect which may be a consequence of the presence of other spot welds is another source of quality variation. This necessitates the development of in-process control techniques that can produce a uniform weld quality regardless of the welding environment changes. Many variables associated with the welding process have been examined for the quality monitoring. More frequently referred variables seem to be the dynamic resistance and the electrode movement. Several attempts have been made to correct weld quality utilizing these variables. One such method is to utilize the dynamic resistance as a quality control variable but essentially an ON-OFF feedback system. Recently a resistance tracking method has been attempted to explore the possibility of using the instantaneous resistance value as an on-line feedback signal. The performance of this tracking control showed that more uniform weld strength can be obtained with this controller. But the control performance appeared to be very sensitive to the choice of controller gain parameters due to the complex shape of the resistance curve. Besides these methods, welding voltage and welding current have been used as a control variable, but these techniques are essentially regulating the control variables to the specified input values and do not use the process state variables for on-line feedback control.

In this approach a new digital control technique is developed to obtain uniform weld quality regardless of the changing welding environments. The control system utilizes a proportional (P) control algorithm, incorporating with the electrode movement as an output feedback variable. In this controller the welding current is generated so as to track a desired trace of the electrode movement (reference electrode movement curve) throughout welding time. The electrode movement trace was measured by a non contacting displacement sensor and sampled via an A/D converter to compute the command control current. A series of experiments was performed to evaluate the performance of this tracking controller. The results show that, as a result of the

electrode movement tracking, the weld strengths of all the weldments approach to a desired strength level.

18. Quality

The word quality comes from Latin and means state or nature. Quality is a word that describes the characteristics of a product or service. The meaning of the word quality differs depending on who you ask and which product or service that is being referred to. The right quality is when the demands put on a product or service is fulfilled. Substandard quality is only when the demands put on a product or service are not fulfilled. Above standard quality is when a product or service fulfills more than what is demanded.

As an example, the demands put on a car used for short trips between your home and your place of work is, for most people, that is reliable and cheap to run. A Rolls Royce fulfils the demand on reliability by a long way and is also very comfortable. In this particular case, the quality of a Rolls Royce is above standard. However, it does not fulfil the requirement of being cheap in mileage costs as the initial purchase price, fuel consumption and insurance together will give a high mileage cost. On the other hand a car that is 15 - 20 years old and has gone more than 200.000 km can be very charming but could not be called reliable and will therefore represent substandard quality. A car buyer's choice, that is to say the one with the right quality in this case, would probably be a small car, perhaps just a few years old but reliable and inexpensive in fuel consumption.

A standardized definition of quality is: "*All the combined characteristics and properties of a given product that gives it the ability to satisfy expressed or implied needs*"

Another definition could be: "*The quality has two dimensions: "must-be quality" "Conformance to specifications" or "fitness for use" (defined by the customer) or and "attractive quality". The latter is what the customer would love, but has not yet thought about. "*

Quality policy

A quality policy describes the company's aims and intentions with regard to quality. The executive management of a company establishes and signs the company's quality policy. This is a requirement specified in the ISO 9000 quality system. A company's quality policy is often briefly described using one or more phrases.

Quality control

A system for verifying and maintaining a desired level of quality in a product or process by careful planning, use of proper equipment, continued inspection, and corrective action as required.

The operations of a company are controlled to give products the right level of quality. This means that the daily activities follow the company's quality system, applying the directions contained in the quality manual and the instructions that are to be available at each workplace.

Quality assurance

A standard definition is that quality assurance is " all planned and systematic activities to give sufficient confidence that a product will fulfil given demands on quality"

Quality Assurance covers all activities from design, development, production, installation, servicing and documentation, this introduced the rules: "fit for purpose" and "do it right the first time". It includes the regulation of the quality of raw materials, assemblies, products and components; services related to production; and management, production, and inspection processes.

In-Process Quality Assurance or IPQA is an emerging field of enquiry in manufacturing technology originating in the 1980s and recently expanding in several areas of welding for aerospace applications. Herein we review the underlying technology for In-Process Quality Assurance as well as recent applications to aerospace and other critical parts manufacture. The historical context of the concept is traced as applied to the aerospace industry in particular.

In-Process Quality Assurance is the direct interrogation of process physics and dynamics as opposed to exclusive reliance on machine tool monitoring or post-process

inspection. In-Process Quality Assurance is complimentary to these other technologies and provides valuable process information not available through other means. Applications to real-time closed loop control are also possible. In this modality of operation, In-Process Quality Assurance is used to preclude the occurrence of defects altogether.

Quality system

A company's quality system gives guidelines to how the business should be organized, managed and controlled as well as how responsibility is to be distributed. The objective of a company's business is to provide products or services with the right level of quality. A quality system describes the procedures, methods and processes that are to be applied.

Quality manual

All the documents describing the quality system in a company must be entered into a quality manual. The contents and appearance of the quality manual usually varies from company to company. The quality manual describes everything from the company's quality policy to the procedures and processes used to attain the quality objectives.

Certification

In order to prove they have a working quality system, a company can apply to be certified. A certification involves an inspection to ensure that the requirements applying to the quality concerned are fulfilled. Such an inspection is called quality audit.

Certifications may be perpetual, may need to be renewed periodically, or may be valid for a specific period of time (e.g. the life-time of the product upon which the individual is certified). Certifications are offered through a certification body. This is usually a business organization. Sometimes, the organization's business is directly related to the certification, In other cases, an organization (often a not-for-profit organization) exists wholly, or in large part, to offer a particular certification. Whatever its nature, the certifying body determines the policies of the certification program. Potential consumers of a certification wish to understand the nature of the certifying body and the certification process.

Personnel

The ability to follow verbal or written instructions and testing of the skill are important factors in ensuring the quality of a welded product. Testing of the skill will be done according to the relevant standard or guideline. Such a test will then lead to a certificate or a diploma. Although it is common in regards to certificates and diplomas, sometimes as part or whole of the renewal of an individual's certification, the individual must show evidence of continual learning — often termed continuing education or life-long-learning.

Accredited certification

Certification carried out according to an accredited certification body. An accredited certification body has received an accreditation from the National accreditation body.

Inspection

To ensure that a product has the right level of quality, some form of inspection is often required. This can involve such things as measuring the dimensions of a welded part, destructive or non-destructive testing and so forth.

A standard definition of Inspection is: " Measurement, investigation, testing or other classification of one or more characteristics or properties of a product and the comparison of the results with the set requirements to determine whether they are fulfilled."

Welding coordination

ISO 14731 "Welding Coordination - Tasks and Responsibilities" is the standard that covers supervision of welding processes and thereby the role and competence of the welding coordinator.

Welding is a special process which requires the coordination of welding operation in order to establish confidence in welding fabrication and reliable performance in service. The tasks and responsibilities of personnel involved in welding and related activities, e.g. planning, executing, supervising and inspection should be clearly defined.

For all tasks assigned, welding coordination personnel shall be able to demonstrate adequate technical knowledge to enable such tasks to be performed satisfactorily. The following factors should be considered:

-general technical knowledge

-special technical knowledge relevant to the assigned tasks. This may be attained by a combination of theoretical knowledge, training and/or experience.

The extent of required manufacturing experience, education and technical knowledge should be decided by the manufacturing organization and will depend on the assigned tasks and responsibilities.

Authorized welding coordination personnel should normally be allocated from one of the following groups. This will depend on the nature and/or complexity of the production. Adequate manufacturing experience need not necessarily be longer than three years.

ISO 3834

For welded constructions to be effective and free from serious problems in production and in service, it is necessary to provide controls, from the design phase, through material selection, into fabrication and subsequent inspection.

For example, poor design for welding may create serious and costly difficulties in the workshop, on site, or in service. Incorrect material selection may result in welding problems, such as cracking. Welding procedures have to be correctly formulated and approved to avoid imperfections. Supervision needs to be implemented to ensure that the specified quality will be achieved.

For the manufacturing industries a set standards, ISO 3834, with appropriate guidelines have been developed. These guidelines are intended to be used for the following purposes:

a) providing interpretation of the requirements in the EN ISO 9000 series of standards, as a guideline for specification and establishment of the part of the quality system related to control of welding as a "Special Process".

b) providing guidelines to establish specifications and welding quality requirements where a quality system according to EN ISO 9001 and EN ISO 9003 is not involved

c) assessment of the welding quality requirements mentioned in a) and b) above.

The applicable party of ISO 3834 (2, 3 or 4) for stand alone assessment and certification of welded operations and activities will depend on the nature of the welding activities required to meet the agreed specifications and influenced by how critical the welding operations are to the quality and fitness of the final product.

Common to all three levels of ISO 3834;

- All welders must take a welding test in compliance with EN 287 or EN ISO 9606 series of standards.
- All welding operators must take a welding test in compliance with EN 1418.
- Welding Inspectors for NDT must be qualified in compliance with EN 473
- Demands on description (not ISO 3834-4) and maintenance of equipment such as welding power sources and heating chambers
- A WPS (Welding Procedure Specification) or a WI (Welding Instruction) is used to control the welding process(Not ISO 3834-4)
- Filler material must be handled in accordance to the manufacturer's instruction.

As can be seen above, even quality control of welding process in compliance with the simplest and least comprehensive standard, ISO 3834-4, demands the application of the most important parts of the new European standards.

19. Welding Gases and Fumes

Welding gases and fumes can be hazardous to your health. The health risks and effects associated with welding gases and fumes are determined by: the length of time that you are exposed to them the type of welding you do the work environment the protection you use. All welding processes produce hazardous gases. Gases are invisible to the eye, and may or may not have an odour. The heat in both the flame and the arc, and the ultraviolet radiation from the arc, produce gases such as carbon monoxide, carbon dioxide, oxides of nitrogen and ozone. Other gases and vapours may be produced as by-products from the breakdown of solvents or coatings on the metal. Gases used for arc shielding, or as a fuel, are also given off during welding. Welding also produces fumes. Fumes are formed when hot metal vapours cool and condense into very small particles that stay suspended in the vapour or the gas. The particles may be metal or metal compounds, and are often smaller than one micrometre (one-fiftieths) the width of a human hair). Fumes may be visible or not. Welding “smoke” is an example of a visible fume. But even if the fume can’t be seen, its particles are still present.

Gases, vapours and fumes enter the body through the air we breathe. Different gases and fumes affect us in various ways. A healthy body can rid itself of some gases and fumes without lasting effects. Gases such as carbon dioxide and argon, for example, are relatively non-toxic unless inhaled in large quantities. However, gases such as carbon monoxide, nitrogen oxides and ozone are extremely toxic.

The health effects of inhaling fumes depend on the type of fume inhaled. Iron oxides, which are produced during most manual welding processes, are relatively non-toxic. The effects, as currently known, are not permanent unless tobacco smoke or other substances, such as silica and asbestos, have already affected your lungs. Effects such as breathing problems tend to disappear over time — once exposure is reduced or stopped. Fumes such as those produced during the welding of stainless steel may produce serious and long-lasting problems. These can include chronic breathing difficulty and cancer, in the case of exposure to chromium.

References:

1. John A Schey, *Introduction to Manufacturing Processes, Mcgraw Hill, 3rd Edition, 2000.*
2. A. Ghosh and A. K. Mallik, *Manufacturing Science, Affiliated East-West Press Private Limited, New Delhi, 2001.*
3. J. Campbell, *Casting, Butterworth-Heinemann, 2003.*
4. M F Ashby, *Material Selection in Mechanical Design, Butterworth-Heinemann, 1999.*
5. G E Dieter, *Mechanical Metallurgy, McGraw-Hill, 1961.*
6. J. B. Bralla, *“Design for manufacturability handbook”, McGraw hill handbooks, 2nd edition, New york.*
7. <http://www.substech.com/dokuwiki/>
8. Deter G. E., *Engineering Design, Mc Graw-Hill, 1999*