

---

## SYLLABUS

Subject Code: 15ELE15/25  
No. of Lecture Hrs./ Week : 04  
Total No. of Lecture Hrs. : 50

IA Marks : 20  
Exam Hours : 03  
Exam Marks : 80

### Course objectives:

- Impart a basic knowledge of electrical quantities such as current, voltage, power, energy and frequency to understand the impact of technology in a global and societal context.
- Provide working knowledge for the analysis of basic DC and AC circuits used in electrical and electronic devices.
- Develop selection skill to identify the type of generators or motors required for particular application
- Highlight the importance of transformers in transmission and distribution of electric power.
- Emphasize the effects of electric shock and precautionary measures.
- Improve the ability to function on multi-disciplinary teams

### Module – 1

**1a. D.C.Circuits:** Ohm's Law and Kirchhoff's Laws, analysis of series, parallel and series-parallel circuits excited by independent voltage sources. Power and Energy. Illustrative examples.

**1b. Electromagnetism:** Review of field around a conductor, coil, magnetic flux and flux density, magneto motive force and magnetic field intensity, reluctance and permeability, definition of magnetic circuit and basic analogy between electric and magnetic circuits. **5 Hours**

**Electromagnetic induction:** Definition of Electromagnetic Induction, Faradays Laws, Fleming's right hand rule, Lenz's Law, Statically and dynamically induced emf. Concept of self-inductance, mutual inductance and coefficient of coupling. Energy stored in magnetic field. Illustrative examples. Force on current carrying conductor placed in a magnetic field, Fleming's left hand rule. **5 Hours**

**Module – 2**

**2a. D.C. Machines:** Working principle of D.C. Machine as a generator and a motor. Types and constructional features. Types of armature windings, Emf equation of generator, relation between induced emf and terminal voltage with an enumeration of brush contact drop and drop due to armature reaction. Illustrative examples, neglecting armature reaction. Operation of D.C. motor, back emf and its significance, torque equation. Types of D.C. motors, characteristics and applications. Necessity of a starter for D.C. motor. Illustrative examples on back emf and torque.

**7 Hours**

**2b. Measuring Instruments:** Construction and Principle of operation of dynamometer type wattmeter and single phase induction type energy meter.

**3 Hours****Module – 3**

**3a. Single-phase A.C. Circuits :** Generation of sinusoidal voltage, frequency of generated voltage, definition and numerical values of average value, root mean square value, form factor and peak factor of sinusoidally varying voltage and current, phasor representation of alternating quantities. Analysis, with phasor diagrams, of R, L, C, R-L, R-C and R-L-C circuits and, parallel and series- parallel circuits. Real power, reactive power, apparent power and power factor. Illustrative examples.

**7 Hours**

**3b. Domestic Wiring:** Service mains, meter board and distribution board. Brief discussion on concealed conduit wiring. Two-way and three-way control. Elementary discussion on Circuit protective devices: fuse and Miniature Circuit Breaker (MCB's). Electric shock, precautions against shock–Earthing, Earth leakage circuit breaker (ELCB) and Residual current circuit breaker (RCCB).

**3 Hours****Module – 4**

**4a. Three Phase Circuits :** Necessity and advantages of three phase systems, generation of three phase power. Definition of Phase sequence, balanced supply and balanced load. Relationship between line and phase values of balanced star and delta connections. Power in balanced three-phase circuits, measurement of power by two-wattmeter method. Determination power factor using wattmeter readings. Illustrative examples.

**6 Hours**

**4b. Three Phase Synchronous Generators:** Principle of operation, Types and constructional features, Advantages of rotating field type alternator, Synchronous speed, Frequency of generated voltage, Emf equation. Concept of winding factor (excluding the derivation of distribution and pitch factors). Illustrative examples on emf equation. **4 Hours**

### **Module – 5**

**5a. Single Phase Transformers:** Necessity of transformer, Principle of operation and construction of single-phase transformers (core and shell types). Emf equation, losses, variation losses with respect to load, efficiency, Condition for maximum efficiency, Voltage regulation and its significance (Open Circuit and Short circuit tests, equivalent circuit and phasor diagrams are excluded). Illustrative problems on emf equation and efficiency only. **6 Hours**

**5b. Three Phase Induction Motors:** Principle of operation, Concept and production of rotating magnetic field, Synchronous speed, rotor speed, Slip, Frequency of the rotor induced emf, Types and Constructional features. Slip and its significance. Applications of squirrel - cage and slip – ring motors. Necessity of a starter, starting of motor using stars-delta starter. Illustrative examples on slip calculations. **4 Hours**

### **TEXT BOOKS**

- 1 “Basic Electrical Engineering”, D C Kulshreshtha, TMH, 2009 Edition.
- 2 “Fundamentals of Electrical Engineering”, Rajendra Prasad, PHI, Second Edition, 2009.

### **REFERENCE BOOKS:**

1. "Electrical Technology", E. Hughes International Students 9<sup>th</sup> Edition, Pearson, 2005.
2. “Basic Electrical Engineering”, Abhijit Chakrabarti, Sudiptanath, Chandan Kumar Chanda, TMH, First reprint 2009.
3. Problems in Electrical Engineering, Parker Smith, CBS Publishers and Distributors, 9<sup>th</sup> Edition, 2003.

**CONTENTS**

<b>Sl. No</b>	<b>TOPICS</b>	<b>PAGE NO.</b>
<b>1.</b>	<b>Module-1: 1a) DC Circuits 1b) Electromagnetism</b>	<b>5-19</b>
<b>2.</b>	<b>Module-2: 2 a) D.C. Machines 2 b) Measuring Instruments</b>	<b>20-36</b>
<b>3.</b>	<b>Module-3 3a) Single-phase A.C. Circuits 3 b) Domestic Wiring</b>	<b>37-88</b>
<b>4.</b>	<b>Module-4 4 a) Three Phase Circuits 4 b) Three Phase Synchronous Generators</b>	<b>89-106</b>
<b>5.</b>	<b>Module-5 5 a) Single Phase Transformers 5 b) Three Phase Induction Motors</b>	<b>107-134</b>

## MODULE – 1

### 1. D. C. Circuits

Ohm's Law: the current flowing through the electric the electric circuit is directly proportional to the potential difference across the circuit and inversely proportional to the resistance of the circuit, provided the temperature remains constant.

The limitations of the Ohm's law are,

- 1) It is not applicable to the nonlinear devices such as diodes, zener diodes, voltage regulators ect.
- 2) It does not hold good for non-metallic conductors such as silicon carbide.

The law for such conductors is given by,

$$V = K I^m \quad \text{where } k, m \text{ are constants.}$$

(I) Current is what flows on a wire or conductor like water flowing down a river. Current flows from negative to positive on the surface of a conductor. Current is measured in (A) amperes or amps.

(E) Voltage Ohm's Law defines the relationships between (P) power, (E) voltage, (I) current, and (R) resistance. One ohm is the resistance value through which one volt will maintain a current of one ampere is the difference in electrical potential between two points in a circuit. It's the push or pressure behind current flow through a circuit, and is measured in (V) volts.

(R) Resistance determines how much current will flow through a component. Resistors are used to control voltage and current levels. A very high resistance allows a small amount of current to flow. A very low resistance allows a large amount of current to flow. Resistance is measured in  $\Omega$  ohms.

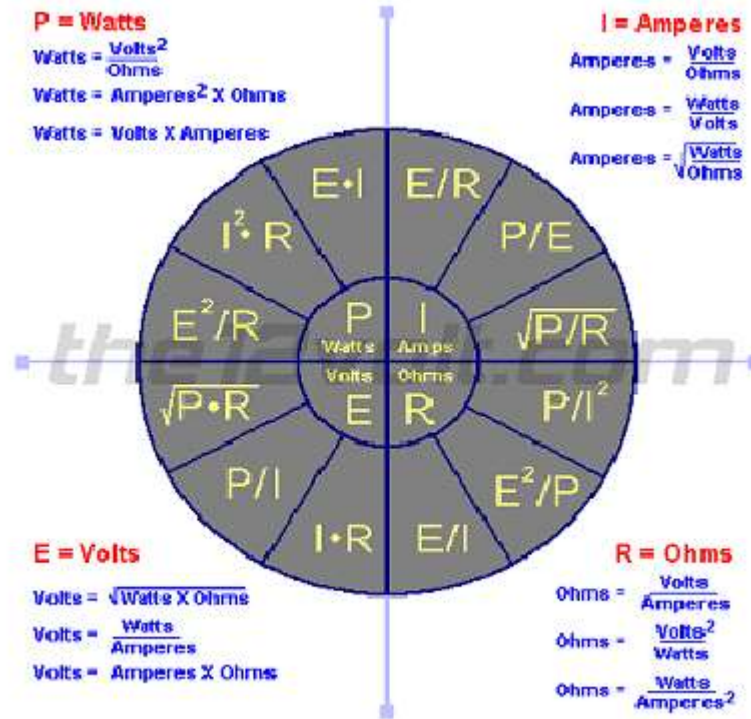

To make a current flow through a resistance there must be a voltage across that resistance. Ohm's Law shows the relationship between the voltage (V), current (I) and resistance (R). It can be written in three ways:

$$V = I \times R \quad \text{or} \quad I = \frac{V}{R} \quad \text{or} \quad R = \frac{V}{I}$$

**where:** V = voltage in volts (V)      **or:** V = voltage in volts (V)  
I = current in amps (A)                      I = current in milliamps (mA)  
R = resistance in ohms (Ω)                      R = resistance in kilohms (kΩ)

**State and explain Kirchhoff's laws.**

Kirchhoff's current law:

The law can be stated as,

The total current flowing towards a junction point is equal to the total current flowing away from that junction point.

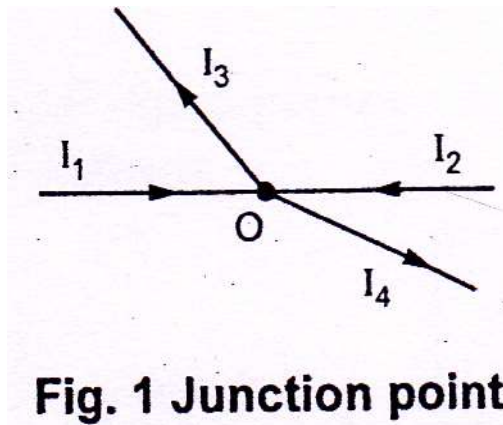

**Fig. 1 Junction point**

- The word algebraic means considering the signs of various currents.

$$\sum I \text{ at junction point} = 0$$

- Sign convention : Currents flowing towards a junction point are assumed to be positive while currents flowing away from a junction point assumed to be negative.
- e.g. Refer to Fig. 1, currents  $I_1$  and  $I_2$  are positive while  $I_3$  and  $I_4$  are negative.
- Applying KCL,  $\sum I \text{ at junction } \mathbf{0} = 0$
- $I_1 + I_2 - I_3 - I_4 = 0$  i.e.  $I_1 + I_2 = I_3 + I_4$
- The law is very helpful in network simplification.

**Kirchhoff's voltage law :**

“In any network, the algebraic sum of the voltage drops across the circuit elements of any closed path (or loop or mesh) is equal to the algebraic sum of the e.m.f s in the path”

In other words, “the algebraic sum of all the branch voltages, around any closed path or closed loop is always zero.”

$$\text{Around a closed path } \sum V = 0$$

- The law states that if one starts at a certain point of a closed path and goes on tracing and noting all the potential changes (either drops or rises), in any one particular direction, till the starting point reached again, he must be at the same potential with which he started tracing a closed path.
- Sum of all the potential rises must be equal to sum of all the potential drops while tracing any closed path of the circuit. The total change in potential along a closed path is always zero.
- This law is very useful in loop analysis of the network.
- A circuit consists of two parallel resistors having resistance of  $20 \Omega$  and  $30\Omega$  respectively connected in series with  $15\Omega$  .If current through  $15\Omega$  resistor is 3 A,

**Resistance**

Resistance is the property of a component which **restricts the flow of electric current**. Energy is used up as the voltage across the component drives the current through it and this energy appears as heat in the component.



Resistors connected in Series

When resistors are connected in series their combined resistance is equal to the individual resistances added together. For example if resistors R1 and R2 are connected in series their combined resistance, R, is given by: Combined resistance in **series**:

$$R = R1 + R2$$

This can be extended for more resistors:  $R = R1 + R2 + R3 + R4 + \dots$

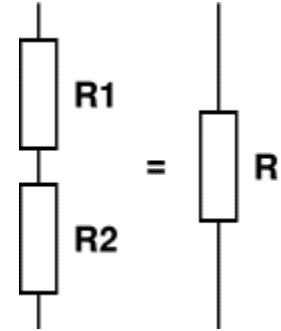

Note that the **combined resistance in series** will always be **greater** than any of the individual resistances.

Resistors connected in Parallel

When resistors are connected in parallel their combined resistance is less than any of the individual resistances. There is a special equation for the combined resistance of **two** resistors R1 and R2:

Combined resistance of **two resistors in parallel**:  $R = \frac{R1 \times R2}{R1 + R2}$

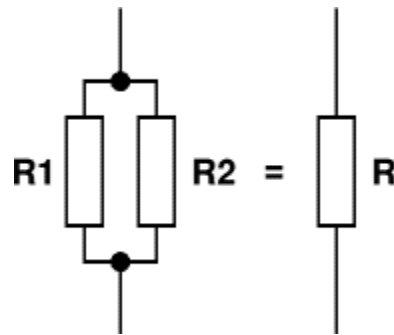

For more than two resistors connected in parallel a more difficult equation must be used. This adds up the **reciprocal** ("one over") of each resistance to give the **reciprocal** of the combined resistance, R:

$$\frac{1}{R} = \frac{1}{R1} + \frac{1}{R2} + \frac{1}{R3} + \dots$$

The simpler equation for **two** resistors in parallel is much easier to use!

Note that the **combined resistance in parallel** will always be **less** than any of the individual resistances.

( P ) **Power** is the amount of current times the voltage level at a given point measured in wattage or watts.

**electrical energy** - energy made available by the flow of electric charge through a conductor; "they built a car that runs on electricity" measured in k Watt Hour

$$\text{Energy} = VIt \text{KWhour}$$

### **Faraday's Laws:**

1<sup>st</sup> law: Whenever magnetic flux linking with a coil changes with time an emf is induced in that coil or whenever a moving conductor cuts the magnetic flux, an emf is induced in the conductor.

2<sup>nd</sup> law: The magnitude of the induced emf is equal to the product of the number of turns of the coil and the rate of change of flux linkage.

### **Lenz's law :**

It states that the direction of an induced emf produced by the electromagnetic induction is such that it sets up a current which always opposes the cause that is responsible for inducing the emf.

In short the induced emf always opposes the cause producing it which is represented by negative sign, mathematically in its expression

Consider a solenoid as shown in Fig.1. Let a bar magnet is moved towards coil such that N-pole of magnet is facing a coil which will circulate the current through the coil.

According to Lenz's law, the direction of current due to induced emf is so as to oppose the cause. The cause is motion of bar magnet towards coil So emf will set up a current through coil in such a way that the end of solenoid facing bar magnet will become N-pole. Hence two like poles will face each other experiencing force of repulsion which is opposite to the motion of bar magnet as shown in the above

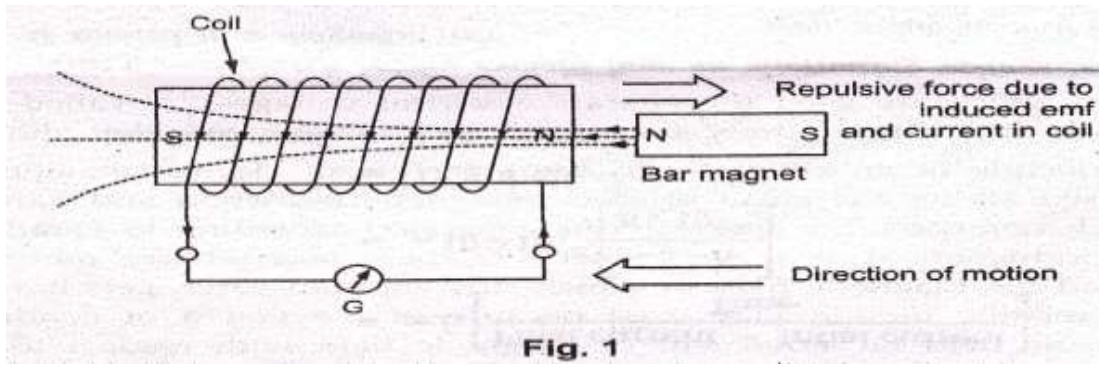
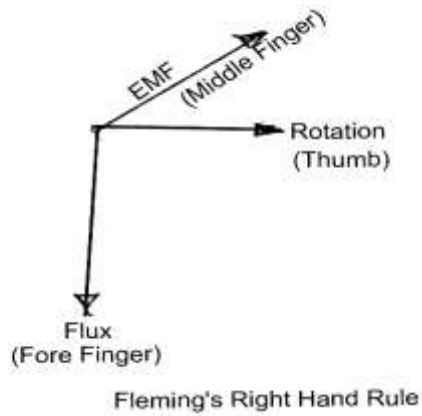

Fig. 1

**Fleming’s rules:**

1. Fleming’s Right hand rule: This rule helps in deciding the direction of the induced emf.



- Hold the right hand thumb, fore finger and the middle finger set at right angles to each other and the *thumb* points the direction of the *motion* of the conductor and the *fore finger* points the direction of the *field* and the *middle finger* points the direction of the induced *emf*.
2. Fleming’s Left hand rule: This rule helps in deciding the direction of force acting on a conductor.

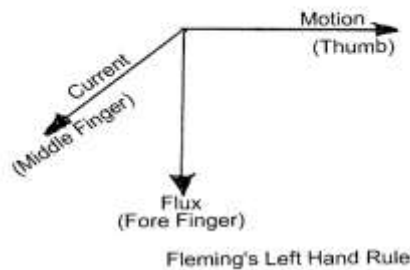

- **Hold the left hand thumb, fore finger and the middle finger set at right angles to each other and the *thumb* points the direction of the *force* acting on the conductor and the direction of the *fore finger* points the direction of the *magnetic field* and the *middle finger* points the direction of the *current in the conductor***

The emf induced in a coil due to change of flux linked with it (change of flux is by the increase or decrease in current) is called statically induced emf. Transformer is an example of statically induced emf. Here the windings are stationary, magnetic field is moving around the conductor and produces the emf.

### **Dynamically induced emf**

The emf induced in a coil due to relative motion of the conductor and the magnetic field is called dynamically induced emf.

**Example:** dc generator works on the principle of dynamically induced emf in the conductors which are housed in a revolving armature lying within magnetic field

### **Statically induced e.m.f**

The change in flux lines with respect to coil can be achieved without physically moving the coil or the magnet. Such induced e.m.f. in a coil which is without physical movement of coil or a magnet is called **statically induced e.m.f.**

To have an induced e.m.f there must be change in flux associated with a coil. Such a change in flux can be achieved without any physical movement by increasing and decreasing the current producing the flux rapidly, with time.

Consider an electromagnet which is producing the necessary flux for producing e.m.f. Now let current through the coil of an electromagnet be an alternating one. Such alternating current means **it changes its magnitude periodically with time**. This produces the flux which is also alternating i.e. changing with time. Thus there exists  $\frac{d\phi}{dt}$  associated with coil placed in the vicinity of an electromagnet. This is responsible for producing an e.m.f in the coil. This is called statically induced e.m.f.

There is no physical movement of magnet or conductor; it is the alternating supply which is responsible for such an induced e.m.f.

Such type of an induced e.m.f. is available in transformers.

**Dynamically induced e.m.f.**

The change in the flux linking with a coil, conductor or circuit can be brought about by its motion relative to magnetic field. This is possible by moving flux with respect to coil conductor or circuit or it is possible by moving conductor, coil, circuit with respect to stationary magnetic flux.

Such an induced e.m.f. which is due to **physical movement** of coil, conductor with respect to flux or movement of magnet with respect with to stationary coil, conductor is called **dynamically induced e.m.f. or motional induced e.m.f.**

This type of induced e.m.f. is available in the rotating machines such as alternators, generator etc.

**Self inductance :**

According to Lenz's law the direction of this induced e.m.f. will be so as to oppose the cause producing it. The cause is the current  $I$  hence self-induced e.m.f will try to set up a current which is in opposite direction to that of current  $I$ . When current is increased, self-induced e.m.f. reduces the current tries to keep to its original value. If current is decreased, self-induced e.m.f. increases the current and tries to maintain it back to its original value. So any change in current through coil is opposed by the coil.

This property of the coil which opposes any change in the current passing through it is called self-inductance or only inductance.

It is analogous to electrical inertia or electromagnetic inertia.

The formula for self-inductance is given by,

$$L = \frac{N\Phi}{I}$$

It can be defined as flux linkages per ampere current in it. Its unit is Henry (H)

**Expressions for coefficient of self-inductance (L):**

$$L = \frac{N\Phi}{I}$$

$$\text{But } \Phi = \frac{\text{mmf}}{\text{reluctance}}$$

$$= \frac{NI}{S}$$

$$\therefore L = \frac{N \cdot NI}{I \cdot S}$$

$$\therefore L = \frac{N^2}{S} \text{ henries}$$

Now  $s = \frac{1}{\mu a}$

$$L = \frac{N^2}{\left(\frac{1}{\mu a}\right)}$$

$$\therefore L = \frac{N^2 \mu a}{l} = \frac{N^2 \mu_0 \mu_r a}{l} \text{ Henries}$$

Where  $l$  = length of magnetic circuit

$a$  = area of cross-section of magnetic circuit which flux is passing.

### Derive an Expression for energy stored in the inductor:

Let the induced e.m.f. in a coil be,

$$e = -L \frac{di}{dt}$$

This opposes a supply voltage. So supply voltage 'V' supplies energy to overcome this, which ultimately gets stored in the magnetic field.

$$\therefore V = -e = -\left[-L \frac{di}{dt}\right] = L \frac{di}{dt}$$

$$\therefore \text{Power supplied} = V \times I = L \frac{di}{dt} \times I$$

$\therefore$  Energy supplied in time  $dt$  is,

$$E = \text{power} \times \text{time} = L \frac{di}{dt} \times I \times dt$$

$$= L di \times I \text{ joules.}$$

This is energy supplied for a change in current of  $dI$  but actually current changes from zero to  $I$ .

$\therefore$  Integrating above total energy stored is,

$$E = \int_0^I L di \ I = L \int_0^I di \ I$$

**State i) Fleming's right hand rule, and**

**ii) Fleming's left hand rule. And Mention their applications.**

**Fleming's right hand rule :** The Fleming's left hand rule is used to get direction of force experienced by conductor carrying current placed in magnetic field while Fleming's right hand rule can be used to get direction of induced e.m.f. when conductor is moving at right angles to the magnetic field.

According to this rule, outstretch the three fingers of right hand namely the thumb, fore finger and the middle finger, perpendicular to each other. Arrange the right hand so that finger point in the direction of flux lines ( from N to S ) and thumb in the direction of motion of conductor with respect to the flux then the middle finger will point in the direction of the induced e.m.f. ( or current ).

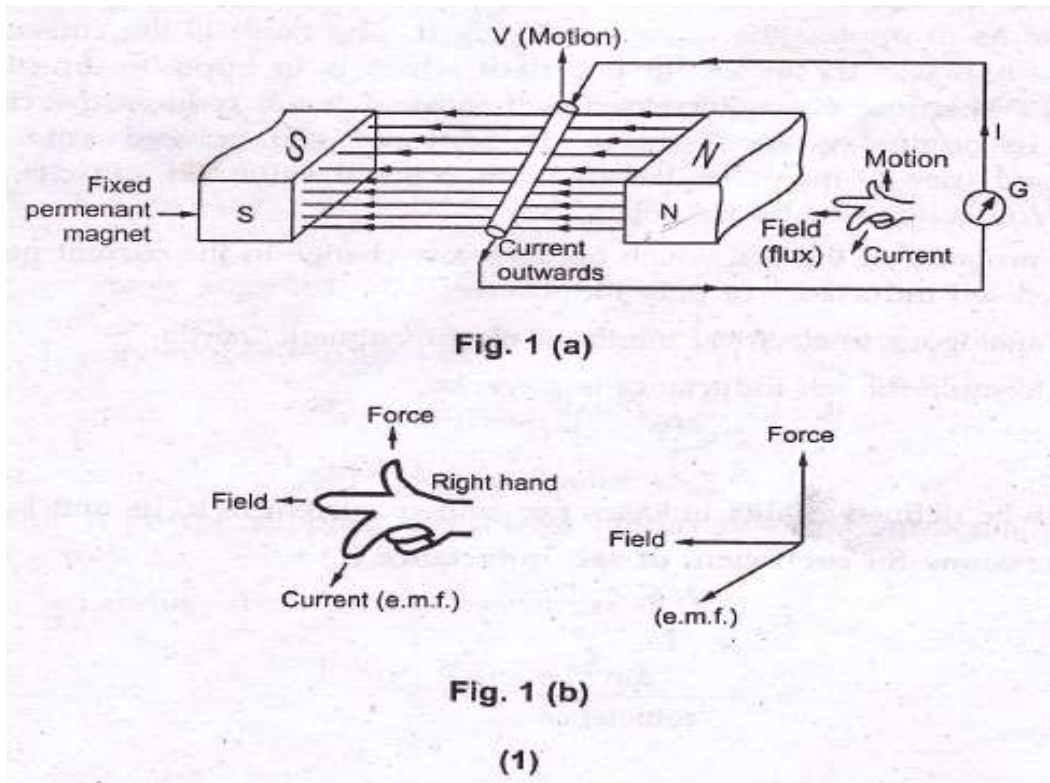

**Fleming’s left hand rule:** The direction of the force experienced by the current carrying conductor placed in magnetic field can be determined by a rule called ‘Fleming’s left hand rule’. The rule states that ‘ outstretch the three fingers on the left hand namely the first finger, middle finger and thumb such that they are mutually perpendicular to each other. Now point the first finger in the direction of magnetic field and middle finger in the direction of the current then the thumb gives the direction of the force experienced by the conductor.’

The rule is explained in the diagrammatic form in fig. 2.

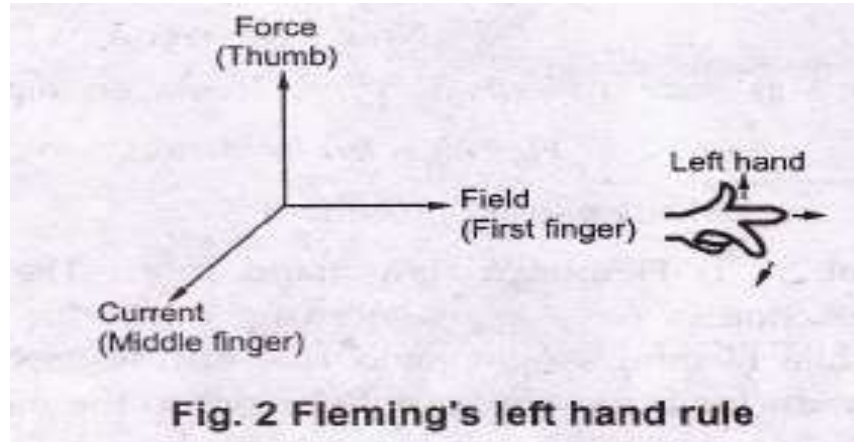

**Applications:** Fleming's right hand rule is used to get the direction of induced emf in case of generators and alternators while left hand rule is used to get the direction of torque induced in motors.

### Mutual inductance:

Magnitude of mutually induced e.m.f

Let

$N_1$  = Number of turns of coil A

$N_2$  = Number of turns of coil B

$I_1$  = Current flowing through coil A

$\Phi_1$  = Flux produced due to current  $I_1$  in webers.

$\Phi_2$  = Flux linking with coil B

According to Faraday's law, the induced e.m.f. in coil B is,

$$e_2 = -N_2 \frac{d\Phi_2}{dt}$$

Negative sign indicates that this e.m.f will set up a current which will oppose the change of flux linking with it.

Now

$$\Phi_2 = \frac{\Phi_2}{I_1} \times I_1$$

If permeability of the surroundings is assumed constant then  $\Phi_2 \propto I_1$  and hence  $\Phi_2/I_1$  is constant.

$\therefore$  Rate of change of  $\Phi_2 = \frac{\Phi_2}{I_1} \times$  Rate of change of current  $I_1$

$$\therefore \frac{d\Phi_2}{dt} = \frac{\Phi_2}{I_1} \cdot \frac{dI_1}{dt}$$

$$\therefore e_2 = -N_2 \cdot \frac{\Phi_2}{I_1} \cdot \frac{dI_1}{dt}$$



$$\therefore e_2 = - \left( \frac{N_2 \phi_2}{I_1} \right) \frac{dI_1}{dt}$$

Here  $\left( \frac{N_2 \phi_2}{I_1} \right)$  is called coefficient of mutual inductance denoted by M

$$e_2 = -M \frac{dI_1}{dt} \quad \text{Volts}$$

Coefficient of mutual inductance is defined as the property by which e.m.f gets induced in the second coil because of change in current through first coil.

Coefficient of mutual inductance is defined as the property by which e.m.f gets induced in the second coil because of change in current through first coil.

Coefficient of mutual inductance is also called mutual inductance. It is measured in Henries.

#### Definitions of mutual inductance and its unit:

- 1) The coefficient of mutual inductance is defined as the flux linkages of the coil per ampere current in other coil.
- 2) It can also be defined as equal to e.m.f induced in volts in one coil when current in other coil changes uniformly at rate of one ampere per second.

#### Similarly its unit is defined as follows:

- 1) Two coils which are magnetically coupled are said to have mutual inductance of one henry when a current of one ampere flowing through one coil produces a flux linkage of one Weber turn in the other coil.
- 2) Two coils which are magnetically coupled are said to have mutual inductance of one Henry when a current changing uniformly at the rate of one ampere per second in one coil, induces an e.m.f of one volts in the other coil.

#### Expressions of the mutual inductance (M):

$$1) \quad M = \frac{N_2 \phi_2}{I_1}$$

- 2)  $\phi_2$  is the part of the flux  $\phi_1$  produced due to  $I_1$ . Let  $K_1$  be the fraction of  $\phi_1$  which is linkage with coil B.

$$\therefore \phi_2 = K_1 \phi_1$$

$$M = \frac{N_2 K_1 \phi_1}{I_1}$$

3) The flux  $\phi_1$  can be expressed as,

$$\phi_1 = \frac{\text{m.m.f}}{\text{reluctance}} = \frac{N_1 I_1}{S}$$

$$M = \frac{N_2 K_1}{I_1} \left( \frac{N_1 I_1}{S} \right)$$

$$M = \frac{K_1 N_1 N_2}{S}$$

If all the flux produced by the coil A links with coil B  $K_1 = 1$ .

$$M = \frac{N_1 N_2}{S}$$

4) Now  $S = \frac{l}{\mu a}$  and  $K_1 = 1$

Then 
$$M = \frac{N_1 N_2}{\left(\frac{l}{\mu a}\right)} = \frac{N_1 N_2 a \mu}{l}$$

$$M = \frac{N_1 N_2 a \mu_0 \mu_r}{l}$$

5) If second coil carries current  $I_2$ , producing flux  $\phi_2$ , the part of which links with coil A i.e.  $\phi_1$  then,

$$\phi_1 = K_2 \phi_2 \quad \text{and}$$

$$M = \frac{N_1 \phi_2}{I_2}$$

$$M = \frac{N_1 K_2 \phi_2}{I_2}$$

Now 
$$\phi_2 = \frac{N_2 I_2}{S}$$

$$M = \frac{N_1 K_2 N_2 I_2}{I_2 S} \quad \text{therefore} \quad M = \frac{N_1 K_2 N_2}{S}$$

**Coupling Coefficient:** The coefficient of coupling is define as the ratio of the actual mutual inductance present between the two coils as the maximum possible value of the mutual inductance. It gives an idea about magnetic coupling between the two coils. This coefficient indicates the amount of linking with other coil which is produced by one coil.

Let  $N_1$  = Number of turns of first coil

$N_2$  = number of turns of second coil

$I_1$  = current through first coil

$I_2$  = current through by first coil

$\phi_1$  = flux produced by first coil

$\phi_2$  = flux produced by second coil

$$\therefore M = \frac{N_2 K_1 \phi_1}{I_1} \quad \text{and} \quad M = \frac{N_1 K_2 \phi_2}{I_2}$$

Multiplying the two expressions,

$$M \times M = \frac{N_2 K_1 \phi_1}{I_1} \times \frac{N_1 K_2 \phi_2}{I_2}$$

$$M_2 = K_1 K_2 \left[ \frac{N_1 \phi_1}{I_1} \right] \left[ \frac{N_2 \phi_2}{I_2} \right]$$

But  $\frac{N_1 \phi_1}{I_1} = L_1$  = self-inductance of first coil

And  $\frac{N_2 \phi_2}{I_2} = L_2$  = self-inductance of second coil

$$\therefore M_2 = K_1 K_2 L_1 L_2$$

$$\therefore M = \sqrt{K_1 K_2} \sqrt{L_1 L_2}$$

Let  $K = \sqrt{K_1 K_2}$  = coefficient of coupling

$$\therefore M = K \sqrt{L_1 L_2}$$

$K = \frac{M}{\sqrt{L_1 L_2}}$
--------------------------------

**MODULE – 2****2a. D.C.Machines:**

A machine which works on direct current is defined as a **D.C.Machine**.

D.C.Machines are of two types. (i) **D.C.Generator** and (ii) **D.C.Motor**.

Sl.No.	D.C. Generator	D.C.Motor
1	<p><b><u>Definition:</u></b></p> <p>A generator is a rotating machine which converts mechanical energy into electrical energy</p>	<p><b><u>Definition:</u></b></p> <p>A motor is a machine which converts electrical energy into mechanical energy</p>
2	<p><b><u>Principle:</u></b></p> <p>Whenever a coil is rotated in a magnetic field an e.m.f. will be induced in this coil and is given by <math>e=Blv\sin\theta</math> volts/coil side</p> <p>where, B=The flux density in Tesla, l=the active length of the coil side in meters, v=the velocity with which the coil is moved in meters/sec and <math>\theta</math> is the angle between the direction of the flux and the direction of rotation of the coil side.</p>	<p><b><u>Principle:</u></b></p> <p>Whenever a current coil is placed under a magnetic field the coil experiences a mechanical force, and is given by <math>F= BI\sin\theta</math> Newtons/coil side.</p> <p>Where, I is the current through the coil in ampere.</p>
3	<p>The direction of the emf induced is fixed by applying the Fleming's right hand rule</p>	<p>The direction of the force acting is fixed by applying the Fleming's left hand rule.</p>

**Types and constructional features**

Salient parts of a D.C.machine are:

- Field system (poles)
- Coil arrangement (armature)
- Commutator
- Brushes
- Yoke

Fig shows the details of a four pole D.C. machine with both shunt and series field windings.

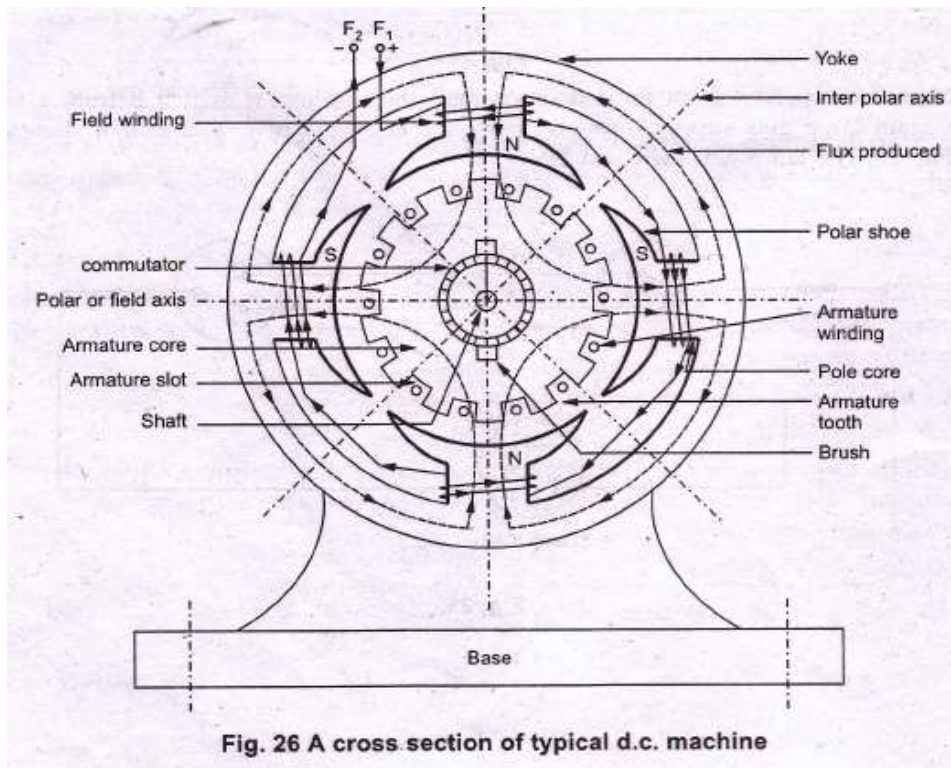

It consists of the following parts:

### Yoke:

#### a) Functions:

- i) It serves the purpose of outermost cover of the d.c. machine. So that the insulating materials get protected from harmful atmospheric elements like moisture, dust and various gases like  $SO_2$ , acidic fumes etc.
- ii) It provides mechanical support to the poles.
- iii) It forms a part of the magnetic circuit. It provides a path of low reluctance for magnetic flux. The low reluctance path is important to avoid wastage of power to provide same flux. Large current and hence the power is necessary if the path has high reluctance, to produce the same flux.

**b) Choice of material:** To provide low reluctance path, it must be made up of some magnetic material. It is prepared by using cast iron because it is cheapest. For large machines rolled steel, cast steel, silicon steel is used which provides high permeability i.e. low reluctance and gives good mechanical strength. As yoke does not need any machining or

good finishing as it rough, casting is the best method of construction of yoke.

### Poles:

Each pole is divided into two parts Namely,

a) pole core and b) pole shoe This is shown in fig. 27.

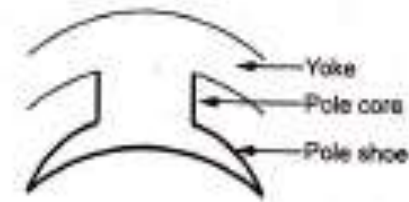

Fig. 27 Pole structure

#### a) Function of pole core and pole shoe:

- i) pole core basically carries a field winding which is necessary to produce the flux.
- ii) It directs the flux produced through air gap to armature core, to the next pole.
- iii) pole shoe enlarges the area of armature core to come across the flux, which is necessary to produce larger induced e.m.f. to achieve this, pole shoe has given a particular shape.

**b) Choice of material:** It is made up of magnetic material like cast iron or cast steel.as it requires a definite shape and size; laminated construction is used. The laminations of required size and shape are stamped together to get a pole, which is then bolted to the yoke.

### Field winding [F1-F2]:

The field winding is wound on the pole core with a definite direction.

**a) Functions:** i) To carry current due to which pole core on which the winding placed behaves as an electromagnet, producing necessary flux.

As it helps in producing the magnetic field i.e. exciting the pole as electromagnet it is called 'Field winding' or 'Exciting winding'.

3) **Explain Choice of material:** As it has to carry current hence obviously made up of some conducting material. So aluminium or copper is the choice. But field coils are required to take any type of shape and bend about pole core and copper has good pliability i.e. it can bend easily. So copper is the proper choice.

Filed winding is divided into various coils called bas field coils. These are connected in series with each other and wound in such a direction around pole cores, such that alternate 'N' and 'S' poles are formed.

By using right hand thumb rule for current carrying circular conductor, it can be easily determined that how a particular core is going to behave as 'N' or 'S' for a particular winding direction around it.

**Armature:**

It is further divided into two parts namely,

I) Armature core and II) Armature winding

I) Armature core is cylindrical in shape mounted on the shaft. It consists of slots on its periphery and the air ducts to permit the air flow through armature which serves cooling purpose.

**a) Functions:**

- i) Armature core provides house for armature winding i.e. armature conductors.
- ii) To provide a path of low reluctance to the magnetic flux produced by the field winding.

**b) Choice of material:** As it has to provide a low Reluctance path to the flux, it is made up of magnetic **material** like cast iron or cast steel.

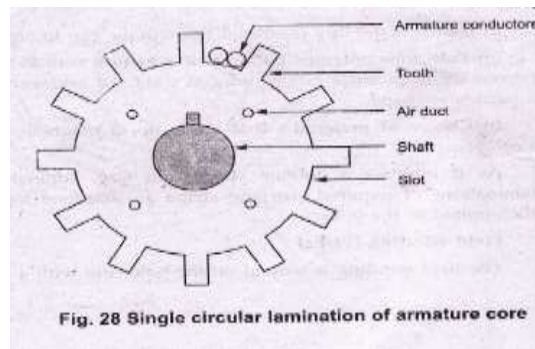

It is made up of laminated Construction to keep eddy current Loss as low as possible. A single circular Lamination used for the construction of the armature core is shown in Fig. 28.

II) Armature winding is nothing but the interconnection of the armature conductors, placed in the slots provided on the armature core periphery. When the armature is rotated, in case of generator, magnetic flux gets cut by armature conductors and e.m.f. gets induced in them.

**a) Functions:**

- i) Generation of e.m.f. takes place in the armature winding in case of generators.
- ii) To carry the current supplied in case of d.c. motors
- iii) To do the useful work in the external circuit.

**b) Choice of material:** As armature windings carries entire current which depends on external load, it has to be made up of conducting material, which is copper.

Armature winding is generally former wound. The conductors are placed in the armature slots which are lined with tough insulating material.

### **Commutator:**

We have seen earlier that the basic nature of e.m.f induced in the armature conductors is alternating. This needs rectifications in case of d.c. generator which is possible by device called commutator.

#### **a) Functions:**

- i) To facilitate the collection of current from the armature conductors.
- ii) To convert internally developed alternating e.m.f. to unidirectional (d.c.) e.m.f.
- iii) To produce unidirectional torque in case of motors.

**b) Choice of material:** As it collects current from armature, it is also made up of copper segments.

It is cylindrical in shape and is made up of wedge shaped segments of hard drawn, high conductivity copper. Those segments are insulated from each other by thin layer of mica. Each commutator segment is connected to the armature conductor by means of copper lug or strip. This connection is shown in the fig.

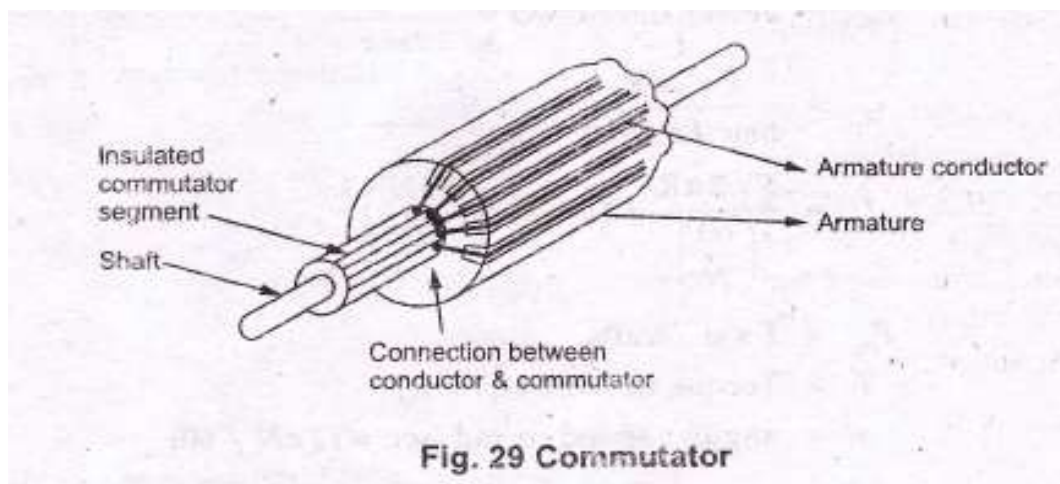



**Brushes and brush gear:**

Brushes are stationary and resting on the surface of the commutator.

**a) Functions:**

i) To collect current from commutator and make it available to the stationary external circuit.

**b) Choice of material:** Brushes are normally made up of soft material like carbon. Brushes are rectangular in shape. They are housed in brush holders, which are usually of box type. The brushes are made to press on the commutator surface by means of a spring, whose tension can be adjusted with the help of lever. A flexible copper conductor called pig tail is used to connect the brush to the external circuit.

**Bearings:**

Ball bearings are usually as they are more reliable. For heavy duty machines, roller bearings are preferred.

**Generated E.M.F. or E.M.F. Equation of a Generator**

Let  $\Phi$  = flux/pole in weber  
 $Z$  = total number of armature conductors

= No. of slots  $\times$  No. of conductors/slot  
 $P$  = No. of generator poles  
 $A$  = No. of parallel paths in armature  
 $N$  = armature rotation in revolutions per minute (r.p.m.)  
 $E$  = e.m.f. induced in any parallel path in armature

Generated e.m.f.  $E_g$  = e.m.f. generated in any one of the parallel paths *i.e.*  $E$ .

Average e.m.f. generated/conductor =  $\frac{d\Phi}{dt}$  volt ( $\because n = 1$ )

Now, flux cut/conductor in one revolution  $d\Phi = \Phi P$  Wb

No. of revolutions/second =  $N/60$   $\therefore$  Time for one revolution,  $dt = 60/N$  second

Hence, according to Faraday's Laws of Electromagnetic Induction,

E.M.F. generated/conductor =  $\frac{d\Phi}{dt} = \frac{\Phi P N}{60}$  volt

### For a simplex wave-wound generator

No. of parallel paths = 2

No. of conductors (in series) in one path =  $Z/2$

$$\therefore \text{E.M.F. generated/path} = \frac{\Phi PN}{60} \times \frac{Z}{2} = \frac{\Phi ZPN}{120} \text{ volt}$$

### For a simplex lap-wound generator

No. of parallel paths =  $P$

No. of conductors (in series) in one path =  $Z/P$

$$\therefore \text{E.M.F. generated/path} = \frac{\Phi PN}{60} \times \frac{Z}{P} = \frac{\Phi ZN}{60} \text{ volt}$$

In general generated e.m.f.  $E_g = \frac{\Phi ZN}{60} \times \left(\frac{P}{A}\right)$  volt

where  $A = 2$ -for simplex wave-winding  
 $= P$ -for simplex lap-winding

### Comparison of lap and wave windings:

LAP	WAVE
Number of armature parallel paths is equal to the number of poles.	Number of parallel paths is always equal to two.
Preferred when large current at lesser voltage is the requirement.	Preferred when large voltage with lesser current is the requirement.

1. A 500V shunt motor has 4 poles and a wave connected winding with 492 conductors. The flux per pole is 0.05 Wb. The full load current is 20 Amps. The armature and shunt field resistances are  $0.1\Omega$  and  $250\Omega$  respectively. Calculate the speed and the developed torque.

Sol:

$$P = 4, V = 500 \text{ volts}$$

$$\Phi = 0.05 \text{ Wb}$$

$$Z = 492$$

$$I_L = I_{F.L.} = 20 \text{ A}$$

$$R_a = 0.1\Omega$$

$$R_{sh} = 250\Omega, A = 2 \text{ for wave winding}$$

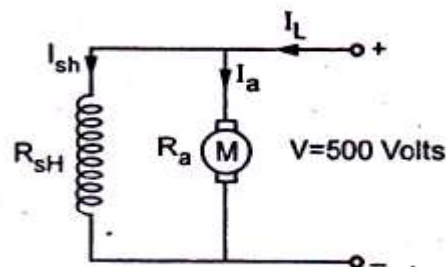

Fig. 11

$$I_{sh} = \frac{V}{R_{sh}} = \frac{500}{250} = 2A$$

$$I_L = I_a + I_{sh} \quad \therefore I_a = I_L - I_{sh} = 20 - 2 = 18A$$

$$\text{Now, } E_b = \frac{\phi ZNP}{60A} = \frac{0.05 \times 492 \times N \times 4}{60 \times 2}$$

$$\text{But, } E_b = V - I_a R_a = 500 - (18)(90.1) = 500 - 1.8$$

$$\therefore 498.2 = \frac{0.05 \times 492 \times N \times 4}{60 \times 2}$$

$$\therefore N = \frac{498.2 \times 2 \times 60}{492 \times 0.05 \times 4}$$

$$\therefore N = 607.56 \text{ rpm}$$

$$\text{Now, } E_b \cdot I_a = T_a \times \omega$$

$$T_a = \frac{E_b \cdot I_a}{\omega} = \left[ \frac{498.2 \times 18}{2\pi \times 607.56} \right]$$

$$T_a = \frac{498.2 \times 18 \times 60}{2\pi \times 607.56}$$

$$T_a = 140.94 \text{ N-m) A 250 KVA, 11000/415V, 50 Hz single phase}$$

**Principle:** Whenever a current coil is placed in a magnetic field the coil experiences a Mechanical force, and is given by

$F = BIl \sin \theta$  newtons. Where B is the flux density in Tesla

I is the current through the coil

l is the active length of the coil side

$\theta$  is the angle between the movement of the

coil and the direction of the flux

The direction of the force acting can be decided by applying Fleming's left hand rule.

The construction of a D.C.Motor is same as the construction of a D.C.generator.

**Types of D.C.Motors:**

Depending on the interconnection between the armature and the field circuit D.C.Motors are classified as (i) Shunt Motor, (ii) Series Motor and (iii) Compound motors just like D.C.Generators.

**Back EMF:**

Whenever a current coil is placed under a magnetic field the coil experiences a mechanical force due to which the coil starts rotating. This rotating coil again cuts the magnetic lines of force resulting an EMF induced in it whose direction is to oppose the applied EMF (as per Fleming's right hand rule), and hence the name **BACK EMF** or **Counter Emf**.

**Significance of Back EMF:** Back EMF is a must in a motor which helps to regulate the armature current and also the real cause for the production of torque.

Expression for the back Emf is given by  $E=V-I_aR_a$ ,

Where E is the back emf, V is the applied emf,  $I_a$  is the armature current and  $R_a$  is the armature circuit resistance. And also  $E= PZN\Phi/60A$  volts, from the machine parameters.

**Production of torque in a D.C. Motor.**

The production of torque in a d.c. motor can be well explained with the help of the following figures.

Fig (a) represents the magnetic field distribution between a bipolar magnet from North pole to South pole.

Fig(b) shows the field set up around a current carrying coil

In fig © the current carrying coil is brought under the influence of bipolar magnetic field.

The resultant field around the coil due to the inter action of the main field and the coil field is seen in fig (d) where in the flux is strengthened in the left part of the upper coil side and weakened in the right part of the upper coil side and vice-versa in the lower coil side. The resultant flux which strengthened at one point exerts a force on the conductor as per Fleming's left hand rule and thereby the coil side experiences a mechanical force.

In the construction it is seen that several coils sides are on the armature and the tangential force acting on each of these coil sides add each other and resulting in a unidirectional movement which makes the armature to rotate at a uniform speed thereby torque is produced.

**TORQUE EQUATION:**

Let  $P$  be the total number of poles,  $Z$  be the total number of armature conductors arranged in  $A$  number of parallel paths. Let  $\Phi$  be the flux per pole,  $N$  be the speed of rotation in rpm, and  $T$  be the torque in Nm.

We know that the back emf  $E = V - I_a R_a$

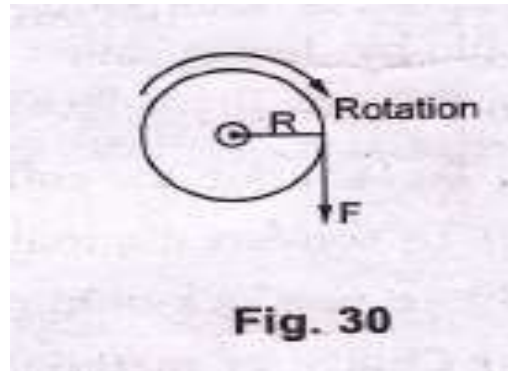

**Fig. 30**

It is seen that the turning or twisting force about an axis is called torque.

Consider a wheel of radius  $R$  meters, acted upon by a Circumferential force of  $F$  Newton's as shown in fig. 30.

The wheel is rotating at a speed of  $N$  r.p.m.

Then angular speed of the wheel is,

$$\omega = \frac{2\pi N}{60} \text{ rad/sec}$$

So work done in one revolution is,

$$\begin{aligned} W &= F \times \text{distance travelled in one revolution} \\ &= F \times 2\pi R \text{ joules} \end{aligned}$$

And  $P_m = \text{power developed} = \frac{\text{work done}}{\text{time}}$

$$= \frac{F \times 2\pi R}{\text{time for 1 rev}}$$

$$= \frac{F \times 2\pi R}{\frac{60}{N}} = (F \times R) \times \left( \frac{2\pi N}{60} \right)$$

$$P_m = T \times \omega$$

where

$$T = \text{Torque in N-m} = (F \times R)$$

$$\omega = \text{angular speed in rad/sec} = (2\pi N/60)$$

Let  $T_a$  be the gross torque developed by the armature of the motor. It is also called armature torque. The gross mechanical power developed in the armature is  $E_b I_a$ , as seen from the power equation. So if speed of the motor is  $N$  r.p.m. then,

Power in armature = Armature torque  $\times \omega$

$$E_b I_a = T_a \frac{2\pi N}{60}$$

But  $E_b$  in a motor given by,  $E_b = \frac{\phi P N Z}{60 A}$

$$\therefore \frac{\phi P N Z}{60 A} \times I_a = T_a \times \frac{2\pi N}{60}$$

$$\therefore T_a = \frac{1}{2\pi} \phi I_a \times \frac{PZ}{A}$$

$$\therefore T_a = 0.159 \phi I_a \frac{PZ}{A} \text{ N-m}$$

This is the torque equation of a d.c. motor.

**2. A 4 pole generator with wave wound armature has 51 slots, each having 24 conductors. The flux per pole is 0.01 Weber. At what speed must the armature rotate to give an induced emf of 220 V? What will be the voltage developed if the winding is lap and the armature rotates at the same speed?**

sol.:  $P = 4$ , for wave winding  $A = 2$

Number of slots = 51, conductors/slot = 24

$$\phi = 0.01 \text{ wb;}$$

$$E = 220 \text{ volts}$$

$$Z = \text{Number of slots} \times \text{conductors/slots}$$

$$= 51 \times 24$$

$$= 1224$$

$$E = \frac{\phi Z N P}{60 A}$$

$$\therefore N = \frac{E \times 60 A}{\phi Z P} = \frac{220 \times 60 \times 2}{0.01 \times 1224 \times 4}$$

$$\therefore N = 539.21 \text{ rpm}$$

Now speed is same but winding is lap  $\therefore A = P$

$$E = \frac{\phi ZNP}{60A} = \frac{\phi ZN}{60} = \frac{0.01 \times 1224 \times 539.21}{60}$$

∴ E = 110 volts

2. A 4 pole, 220 V. lap connected DC shunt motor has 36 slots, each slot containing 16 conductors. It draws a current of 40 A from the supply. The field resistance and armature resistance are 110Ω, 0.1 Ω respectively. The motor develops an output power of 6 kW. The flux per pole is 40 mwb. Calculate

a) the speed b) the torque developed by the armature and c) the shaft torque

Sol.: P = 4, V = 220 volts, slots = 36, A = P = 4

Conductors/slot = 16, Z = 36 × 16 = 576

I<sub>L</sub> = 40 A

R<sub>sh</sub> = 110Ω R<sub>a</sub> = 0.1Ω

P<sub>output</sub> = 6 KW, φ = 40 × 10<sup>-3</sup> wb

$$I_{sh} = \frac{V}{R_{sh}} = \frac{220}{110} = 2A$$

I<sub>L</sub> = I<sub>a</sub> + I<sub>sh</sub>

∴ I<sub>a</sub> = I<sub>L</sub> - I<sub>sh</sub>

$$= 40 - 2 = 38A$$

E<sub>b</sub> = V - I<sub>a</sub>R<sub>a</sub>

∴ E<sub>b</sub> = 220 - (38)(0.1)

$$= 220 - 3.8$$

∴ E<sub>b</sub> = 216.2 volts

Now, 
$$E_b = \frac{\phi ZNP}{60A} \quad \therefore N = \frac{E_b \times 60A}{\phi \cdot Z \cdot P} = \frac{(216.2)(60)(4)}{(40 \times 10^{-3})(576)(4)}$$

∴ N = 563 rpm

$$T_a = 0.159 \phi Z \frac{I_a P}{A} = 0.159 \phi Z I_a$$

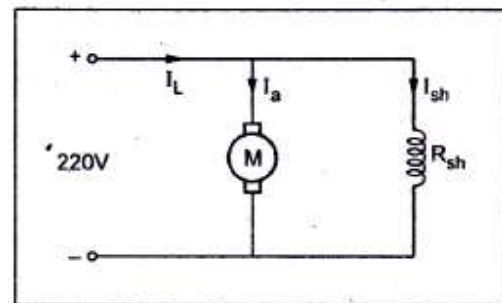

Fig. 9

$$= (0.159) (40 \times 10^{-3}) (576) (38)$$

$$\therefore T_a = 139.20 \text{ N-m}$$

$$P_{\text{out}} = T_{\text{sh}} \cdot \frac{2\pi N}{60}$$

$$T_{\text{sh}} = \frac{P_{\text{out}} \times 60}{2\pi N} = \frac{6 \times 10^3 \times 60}{2\pi \times 563} = 101.76 \text{ N-m}$$

$$\therefore T_{\text{sh}} = 101.76 \text{ N-m}$$

**Characteristics of D.C.Motors:** To study the performance of a motor it is necessary to study the variation of its speed and torque with the variations of the load on it.

There are two types of characteristics: (i) Speed v/s load characteristics

(ii) Torque v/s load characteristics

### 1. Speed/Load characteristics: (a) D.C.Shunt Motor:

In a shunt motor the flux is considered to be constant because of the reason that the field circuit is connected across a constant power supply. Also as the applied voltage is constant the speed is directly proportional to the armature current only, and also as the load is increased the armature current also increases at the same rate and the speed becomes constant. But due to the increased friction at the bearings with the increase of the load there is a small decrease in the speed. The characteristic is shown in the fig. and is compared with the ideal characteristics. The drop in the speed can be reduced by slightly de-exciting the field flux, there by the speed is controlled.

### (b) Series Motor:

In a series motor the flux is solely dependent on the armature current hence the speed variation with load is not like shunt motor. At no load condition only residual flux is in action which is very very small resulting in a dangerously high speed. Therefore series motors are not to be started on no load, which result in the initial speed of dangerously high value called **RUN AWAY SPEED** which severely damages the motor. Hence in series motors there is a provision



of a fly wheel fixed to the shaft which acts like a mechanical load to prevent the motor to attain this high speed.

characteristics of D.C. i) series and ii) shunt motors. Mention two applications of each motor

**DC series motor :**

i)  $N=1$  characteristics :



**Fig. 2 N Vs Ia for series motor**

ii) T-I characteristics :

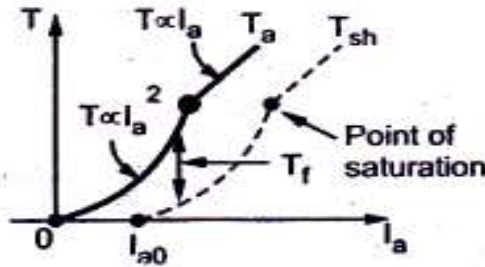
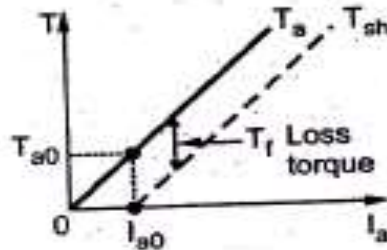

**Fig. 3 T Vs Ia for series motor**

Applications: Cranes, trolleys .

**2. DC shunt motor :**

i) N-I characteristics



**Fig. 4 T Vs Ia for shunt motor**

ii) T-I characteristics:

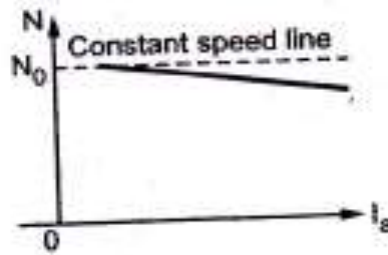
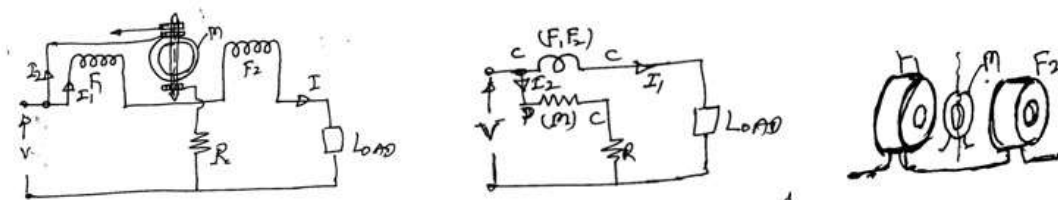

Fig. 5 N Vs Ia for shunt motor

**2b. Measuring Instruments:**

**DYNAMOMETER WATTMETER:-**

In this type there will not be any permanent magnets and there will be a pair of fixed coils connected in series when energized gives the same effect as that of the permanent magnets. In the field of these fixed coils there will be a moving coil which when energized acted upon by a torque by which it deflects



F<sub>1</sub> F<sub>2</sub>: Fixed coils

M: Moving coil

R: High resistance in series with m

I<sub>1</sub> : load current

$I_2$ : current through

The two fixed coils in series act as the current coil and the moving coil in series with R act as the potential coil. The moving coil is pivoted between the two fixed coils carries a current  $I_2$  proportional to V. This current is fed to m through two springs which also provides the necessary controlling torque. This instrument can be used on both ac and dc circuits as both the coils are energized simultaneously by a common source due to which a unidirectional torque is produced.

### INDUCTION TYPE ENERGY METER:-

This is a measuring instrument/device which works on the principle of induction and measures the energy consumed over a definite period.

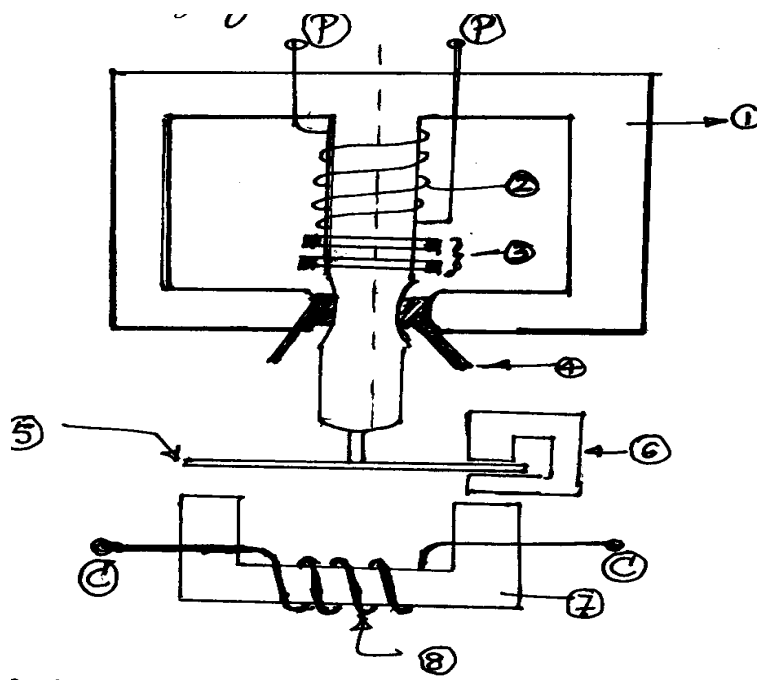

- 1) Upper Magnet/ shunt magnet (P.P)
- 2) Potential coil/ Voltage coil
- 3) Copper Shading bands
- 4) Friction compensator
- 5) Aluminium disc
- 6) Brake magnet

7) Lower magnet/Series magnet

8) Current coil (C-C)

This instrument consisting two electromagnets as in fig.

1. **Upper magnet or Shunt magnet:** which carries the potential coil on its central limb which also carries one or two copper shading bands for the power factor adjustment.
2. **Lower magnet or Series magnet:** Which carries the current coil as shown. An aluminum disc is between the fields of the upper and lower electro magnets. There is a friction compensator in the upper magnets for the measurement at very low loads. The aluminum disc rotates in the field of a brake magnet whose position can be set so that the disc rotates at proper speeds at higher loads.

This instrument works on the principle of induction that when both the shunt and series coils are energized by ac, there will be two alternative fluxes are in the shunt coil and one in the series coil these time varying fluxes are cut by a stationary disc. Inducing currents in the disc. These currents interacts with the fluxes and results in a torque which is given by

$T \propto (k_1 \phi_{sh} i_{se} + K_2 \phi_{se} i_{sh})$  there by the disc rotates in a particular direction and the number and speed of rotations depends on the energy consumed by the load.

Sometimes the energy meters disc rotates slowly even on no load conditions as the potential coil is continuously energized and this effect is called the 'CREEP' and the speed is called the 'CREEP SPEED' to minimum this creep one pair of diametrically opposite holes are made in the aluminum disc which alters the reluctance and minimizes the creep effect.

## MODULE – 3

### 3a.Single-phase A.C. Circuits:

#### **Generation of sinusoidal AC Voltage:**

Alternating voltage may be generated:

- a) By rotating a coil in a magnetic field as shown in Fig.3.1.
- b) By rotating a magnetic field within a stationary coil as shown in Fig.3.2.

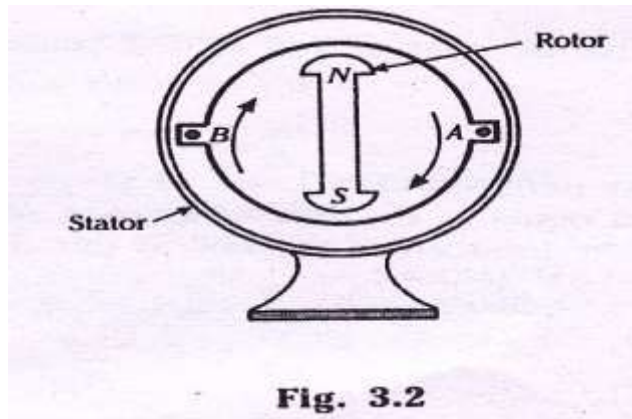
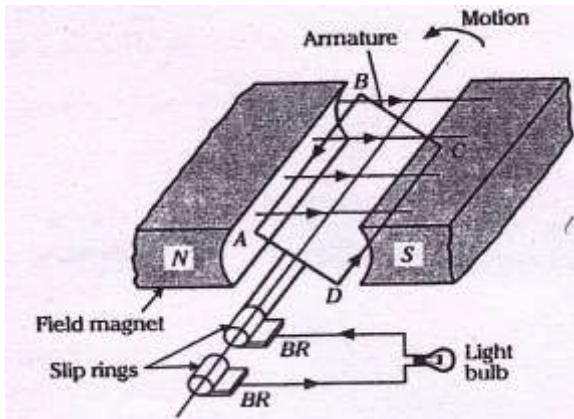

**Fig. 3.2**

“ In each case, the value of the alternating voltage generated depends upon the number of turns in the coil, the strength of the field and the speed at which the coil or magnetic field rotates.”

The alternating voltage generated has regular changes in magnitude and direction. If a load resistance (e.g. a light bulb) is connected across this alternating voltage, an alternating current flows in the circuit. When there is a reversal of polarity of the alternating voltage, the direction of current flow in the circuit also reverses.

#### **Equation of Alternating E.M.F.**

Let us take up the case of a rectangular coil of  $N$  turns rotating in the anticlockwise direction, with an angular velocity of  $\omega$  radians per second in a uniform magnetic field as shown in Fig.3.3. let the time be measured from the instant of coincidence of the plane of the coil with the

X-axis. At this instant maximum flux  $\phi_{\max}$  links with the coil. As the coil rotates, the flux linking with it changes and hence e.m.f. is induced in it. Let the coil turn through an angle  $\theta$  in time ‘t’ seconds, and let it assume the position as shown in Fig.3.3. Obviously  $\theta = \omega t$ .

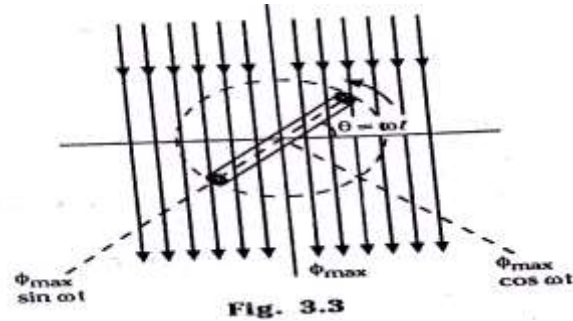

When the coil is in this position, the maximum flux acting vertically downwards can be resolved into two components, each perpendicular to the other, namely:

- a) Component  $\phi_{\max} \sin \omega t$ , parallel to the plane of the coil. This component does not induce e.m.f. as it is parallel to the plane of the coil.
- b) Component  $\phi_{\max} \cos \omega t$ , perpendicular to the plane of coil. This component induces e.m.f. in the coil.

$\therefore$  flux linkages of coil at that instant (at  $\theta^0$ ) is

$$= \text{No. of turns} \times \text{flux linking}$$

$$= N \phi_{\max} \cos \omega t$$

As per Faraday's Laws of Electromagnetic induction, the e.m.f. induced in a coil is equal to the rate of change of flux linkages of the coil. So, instantaneous e.m.f. 'e' induced in the coil at this instant is:

$$\begin{aligned} e &= -\frac{d}{dt} (\text{flux linkages}) \\ &= -\frac{d}{dt} (N \phi_{\max} \cos \omega t) \\ &= -N \phi_{\max} \frac{d}{dt} (\cos \omega t) \\ &= -N \phi_{\max} \omega (-\sin \omega t) \end{aligned}$$

$$\therefore e = + N \phi_{\max} \sin \omega t \text{ volts} \quad \dots (1)$$

It is apparent from eqn.(1) that the value of 'e' will be maximum ( $E_m$ ), when the coil has rotated through  $90^\circ$  (as  $\sin 90^\circ = 1$ )

$$\text{Thus } E_m = N \omega \phi_{\max} \text{ volts} \quad \dots (2)$$

Substituting the value of  $N \omega \phi_{\max}$  from eqn.(2) in eqn.(1), we obtain:

$$e = E_m \sin \omega t \quad \dots (3)$$

We know that  $\theta = \omega t$

$$\therefore e = E_m \sin \theta$$

It is clear from this expression of alternating e.m.f. induced in the coil that instantaneous e.m.f. varies as the sin of the time angle ( $\theta$  or  $\omega t$ ).

$\omega = 2\pi f$ , where 'f' is the frequency of rotation of the coil. Hence eqn.(3) can be written as

$$e = E_m \sin 2\pi ft \quad \dots (4)$$

If  $T =$  time of the alternating voltage  $= \frac{1}{f}$ , then eqn.(iv) may be re-written as

$$e = E_m \sin\left(\frac{2\pi}{T}t\right)$$

so, the e.m.f. induced varies as the sine function of the time angle,  $\omega t$ , and if e.m.f. induced is plotted against time, a curve of sine wave shape is obtained as shown in Fig.3.4. Such an e.m.f. is called sinusoidal when the coil moves through an angle of  $2\pi$  radians.

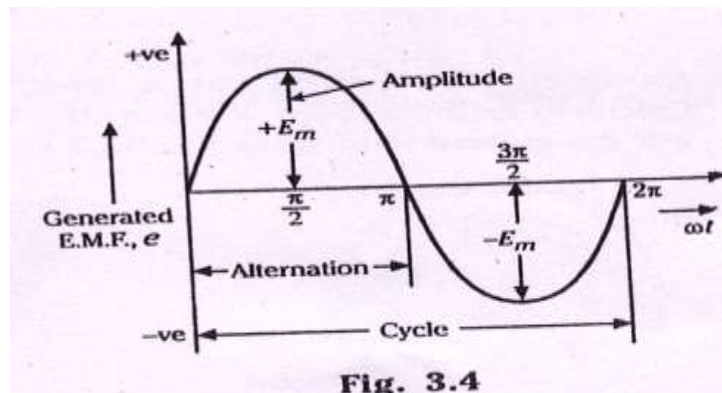

Fig. 3.4

### Equation of Alternating Current

When an alternating voltage  $e = E_m \sin \omega t$  is applied across a load, alternating current flows through the circuit which will also have a sinusoidal variation. The expression for the alternating current is given by:

$$i = I_m \sin \omega t$$

In this case the load is resistive (we shall see, later on, that if the load is inductive or capacitive, this current-equation is changed in time angle).

**Important Definitions**

Important terms/definitions, which are frequently used while dealing with a.c. circuits, are as given below:

1. Alternating quantity: An alternating quantity is one which acts in alternate positive and negative directions, whose magnitude undergoes a definite series of changes in definite intervals of time and in which the sequence of changes while negative is identical with the sequence of changes while positive.
2. Waveform: “The graph between an alternating quantity (voltage or current) and time is called waveform”, generally, alternating quantity is depicted along the Y-axis and time along the X-axis. fig.4.4 shows the waveform of a sinusoidal voltage.
3. Instantaneous value: The value of an alternating quantity at any instant is called instantaneous value.

The instantaneous values of alternating voltages and current are represented by ‘e’ and ‘I’ respectively.

4. Alternation and cycle: When an alternating quantity goes through one half cycle (complete set of +ve or –ve values) it completes an alternation, and when it goes through a complete set of +ve and –ve values, it is said to have completed one cycle.
5. Periodic Time and Frequency: The time taken in seconds by an alternating quantity to complete one cycle is known as periodic time and is denoted by T.

The number of cycles completed per second by an alternating quantity is known as frequency and is denoted by ‘f’. In the SI system, the frequency is expressed in hertz.

The number of cycles completed per second = f.

Periodic Time T – Time taken in completing one cycle =  $\frac{1}{f}$

$$\text{Or } f = \frac{1}{T}$$

In India, the standard frequency for power supply is 50 Hz. It means that alternating voltage or current completes 50 cycles in one second.



6. Amplitude: The maximum value, positive or negative, which an alternating quantity attains during one complete cycle, is called amplitude or peak value or maximum value. The amplitude of alternating voltage and current is represented by  $E_m$  and  $I_m$  respectively.

### Different Forms of E.M.F. Equation

The standard form of an alternating voltage, as already mentioned in sec.3.2 is

$$e = E_m \sin \theta = E_m \sin \omega t = E_m \sin 2\pi f t = E_m \sin \frac{2\pi}{T} t$$

on perusal of the above equations, we find that

- a) The amplitude or peak value or maximum value of an alternating voltage is given by the coefficient of the sine of the time angle.
- b) The frequency 'f' is given by the coefficient of time divided by  $2\pi$ .

Taking an example, if the equation is of an alternating voltages is given by  $e = 20 \sin 314t$ , then its maximum value is 20 V and its frequency is

$$f = \frac{314}{2\pi} 50 \text{ Hz}$$

In a like manner, if the equation is of the form

$$e = I_m \sqrt{(R^2 + 4\omega^2 L^2)} \sin 2 \omega t, \text{ then its maximum value is}$$

$$E_m = I_m \sqrt{(R^2 + 4\omega^2 L^2)} \text{ and the frequency is}$$

$$\frac{2\omega}{2\pi} \text{ Or } \frac{\omega}{\pi} \text{ Hertz}$$

### Root-mean-square (R.M.S.) Value:

The r.m.s. or effective value, of an alternating current is defined as that steady current which when flowing through a given resistance for a given time produces the same amount of heat as produced by the alternating current, when flowing through the same resistance for the same time.

Let us take two circuits with identical resistance, but one is connected to a battery and the other to a sinusoidal voltage source. Wattmeters are employed to measure heat power in each circuit. The voltage applied to each circuit is so adjusted that the heat power produced in each circuit is the same. In this event the direct current  $I$  will equal  $\frac{I_m}{\sqrt{2}}$ , which is termed r.m.s. value of the sinusoidal current.

The following method is used for finding the r.m.s. or effective value of sinusoidal waves.

The equation of an alternating current varying sinusoid ally is given by  $i = I_m \sin \theta$ .

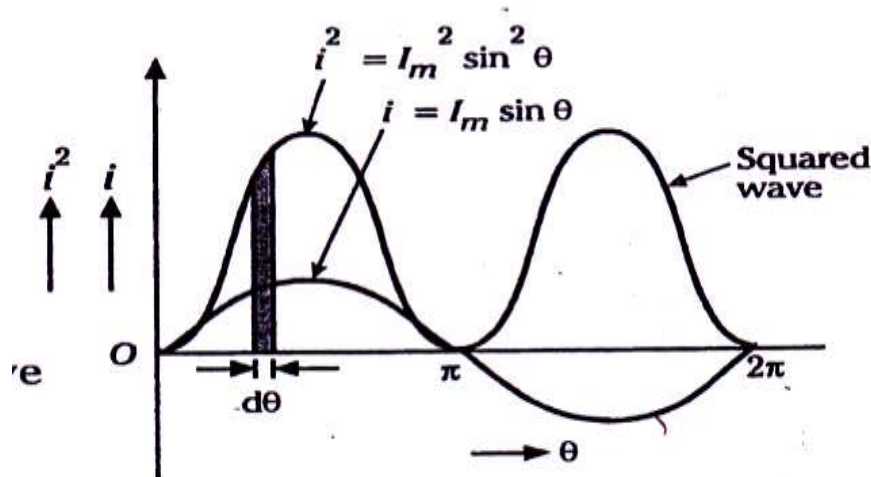

**Fig. 3.5**

Let us consider an elementary strip of thickness  $d\theta$  in the first cycle of the squared wave, as shown in Fig.3.5.

Let  $i^2$  be mid-ordinate of this strip.

$$\text{Area of the strip} = i^2 d\theta$$

Area of first half-cycle of squared wave

$$= \int_0^{\pi} i^2 d\theta$$

$$= \int_0^{\pi} (I_m \sin \theta)^2 d\theta \quad (\because I = I_m \sin \theta)$$

$$= \int_0^{\pi} I_m^2 \sin^2 \theta d\theta$$

$$\begin{aligned}
 &= I_m^2 \int_0^\pi \frac{1 - \cos 2\theta}{2} d\theta && (\because \sin^2 \theta = \frac{1 - \cos 2\theta}{2}) \\
 &= \frac{I_m^2}{2} \int_0^\pi (1 - \cos 2\theta) d\theta \\
 &= \frac{I_m^2}{2} \left[ \theta - \frac{\sin 2\theta}{2} \right]_0^\pi \\
 &= \frac{I_m^2}{2} [(\pi - 0) - (0 - 0)] \\
 &= \frac{\pi I_m^2}{2} \\
 \therefore I &= \sqrt{\frac{\text{Area of first half cycle of squared wave}}{\text{base}}} \\
 &= \sqrt{\frac{\pi I_m^2}{2} \times \frac{1}{\pi}} \\
 &= \sqrt{\frac{I_m^2}{2}} \\
 &= \frac{I_m}{\sqrt{2}} = 0.707 I_m
 \end{aligned}$$

Hence, for a sinusoidal current,

R.M.S. value of current = 0.707 x maximum value of current.

Similarly,  $E = 0.707 E_m$

### Average Value

The arithmetical average of all the values of an alternating quantity over one cycle is called **average value**.

In the case of a symmetrical wave e.g. sinusoidal current or voltage wave, the positive half is exactly equal to the negative half, so that the average value over the entire cycle is zero. Hence, in this case, the average value is obtained by adding or integrating the instantaneous values of current over one alternation (half-cycle) only.

The equation of a sinusoidally varying voltage

Is given by  $e = E_m \sin \theta$ .

Let us take an elementary strip of thickness  $d\theta$  in the first half-cycle as shown in Fig.3.6. let the mid-ordinate of this strip be 'e'.

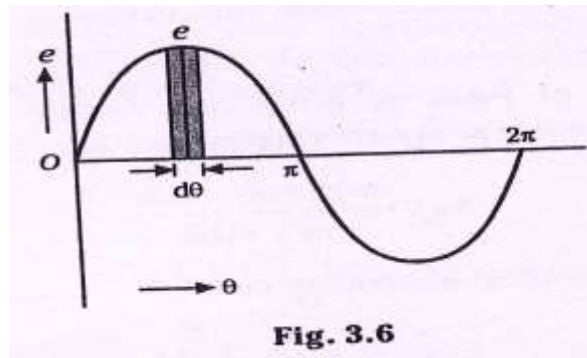

Area of the strip =  $e d\theta$

Area of first half-cycle

$$\begin{aligned}
 &= \int_0^{\pi} e d\theta \\
 &= \int_0^{\pi} E_m \sin \theta d\theta \quad (\because e = E_m \sin \theta) \\
 &= E_m \int_0^{\pi} \sin \theta d\theta \\
 &= E_m [-\cos \theta]_0^{\pi} = 2E_m
 \end{aligned}$$

$$\therefore \text{Average value, } E_{av} = \frac{\text{Area of half cycle}}{\text{base}} = \frac{2E_m}{\pi}$$

$$\text{Or } E_{av} = 0.637 E_m$$

In a similar manner, we can prove that, for alternating current varying sinusoidally,

$$I_{av} = 0.637 I_m$$

**$\therefore$  Average value of current = 0.637 x maximum value**

### **Form Factor and crest or peak or Amplitude Factor ( $K_f$ )**

A definite relationship exists between crest value (or peak value), average value and r.m.s. value of an alternating quantity.

1. Form Factor: The ratio of effective value (or r.m.s. value) to average value of an alternating quantity (voltage or current) is called form factor, i.e.

$$\text{Form Factor, } K_f = \frac{\text{r.m.s. value}}{\text{average value}}$$

For sinusoidal alternating current,

$$K_f = \frac{0.707I_m}{0.637I_m} = 1.11$$

For sinusoidal alternating voltage,

$$K_f = \frac{0.707V_m}{0.637V_m} = 1.11$$

Hence, the R.M.S. value (of current or voltage) is 1.11 times its average value.

2. Crest or Peak or Amplitude Factor ( $K_a$ ): It is defined as the ratio of maximum value to the effective value (r.m.s. value) of an alternating quantity. i.e.,

$$K_a = \frac{\text{maximum value}}{\text{r.m.s.value}}$$

For sinusoidal alternating current,

$$K_a = \frac{I_m}{\frac{I_m}{\sqrt{2}}} = \sqrt{2} = 1.414$$

For sinusoidal alternating voltage,

$$K_a = \frac{V_m}{\frac{V_m}{\sqrt{2}}} = 1.414$$

The knowledge of Crest Factor is particularly important in the testing of dielectric strength of insulating materials; this is because the breakdown of insulating materials depends upon the maximum value of voltage.

### Phase

An alternating voltage or current changes in magnitude and direction at every instant. So, it is necessary to know the condition of the alternating quantity at a particular instant. The location of the condition of the alternating quantity at any particular instant is called its phase.

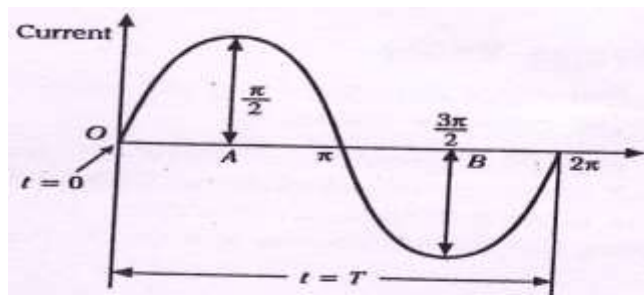

Fig. 3.7

We may define the phase of an alternating quantity at any particular instant as the fractional part of a period or cycle through which the quantity has advanced from the selected origin.

Taking an example, the phase of current at point A (+ve maximum value) is  $T/4$  second, where  $T$  is the time period, or expressed in terms of angle, it is  $\pi/2$  radians (Fig.3.7). In other words, it means that the condition of the wave, after having advanced through  $\pi/2$  radians ( $90^\circ$ ) from the selected origin (i.e.,0) is that it is maximum value (in the positive direction).similarly, -ve maximum value is reached after  $3\pi/2$  radians ( $270^\circ$ ) from the origin, and the phase of the current at point B is  $3T/4$  second.

### Phase Difference (Lagging or Leading of Sinusoidal wave)

When two alternating quantities, say, two voltages or two currents or one voltage and one current are considered simultaneously, the frequency being the same, they may not pass through a particular point at the same instant.

One may pass through its maximum value at the instant when the other passes through a value other than its maximum one. These two quantities are said to have a phase difference. Phase difference is specified either in degrees or in radians.

The phase difference is measured by the angular difference between the points where the two curves cross the base or reference line in the same direction.

The quantity ahead in phase is said to lead the other quantity, whereas the second quantity is said to lag behind the first one. In Fig.3.8, current  $I_1$ , represented by vector  $OA$ , leads the current  $I_2$ , represented by vector  $OB$ , by  $\phi$ , or current  $I_2$  lags behind the current  $I_1$  by  $\phi$ .

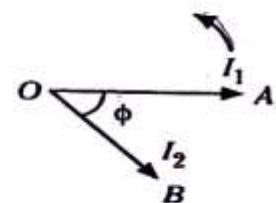
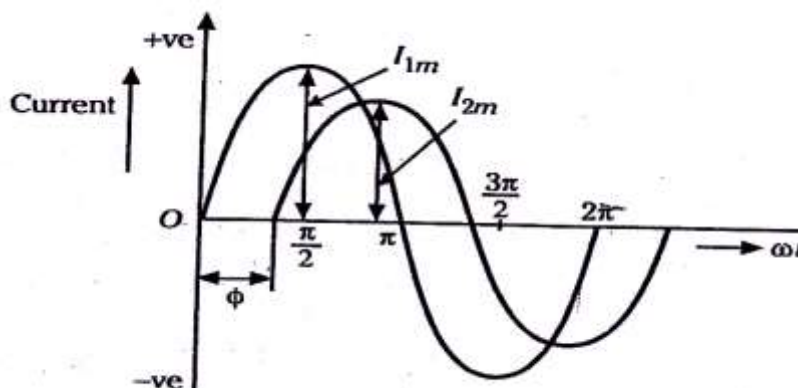

Fig. 3.8

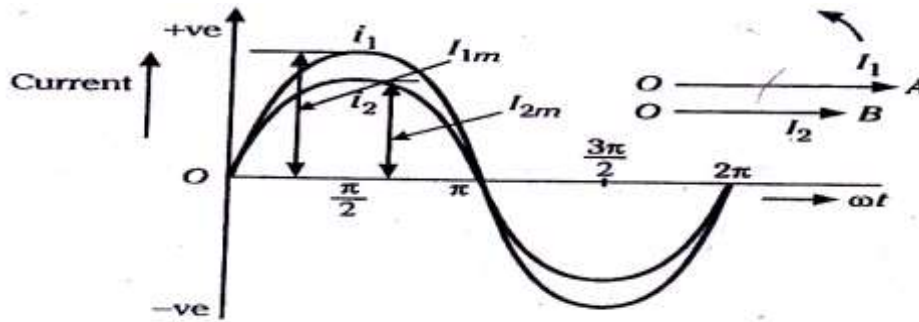

Fig. 3.9

The leading current  $I_1$  goes through its zero and maximum values first and the current  $I_2$  goes through its zero and maximum values after time angle  $\phi$ . The two waves representing these two currents are shown in Fig.3.8. if  $I_1$  is taken as reference vector, two currents are expressed as

$$i_1 = I_{1m} \sin \omega t \quad \text{and} \quad i_2 = I_{2m} \sin (\omega t - \phi)$$

The two quantities are said to be in phase with each other if they pass through zero values at the same instant and rise in the same direction, as shown in Fig.3.9. However, if the two quantities pass through zero values at the same instant but rise in opposite, as shown in Fig.3.10, they are said to be in phase opposition i.e., the phase difference is  $180^\circ$ . When the two alternating quantities have a phase difference of  $90^\circ$  or  $\pi/2$  radians they are said to be in quadrature.

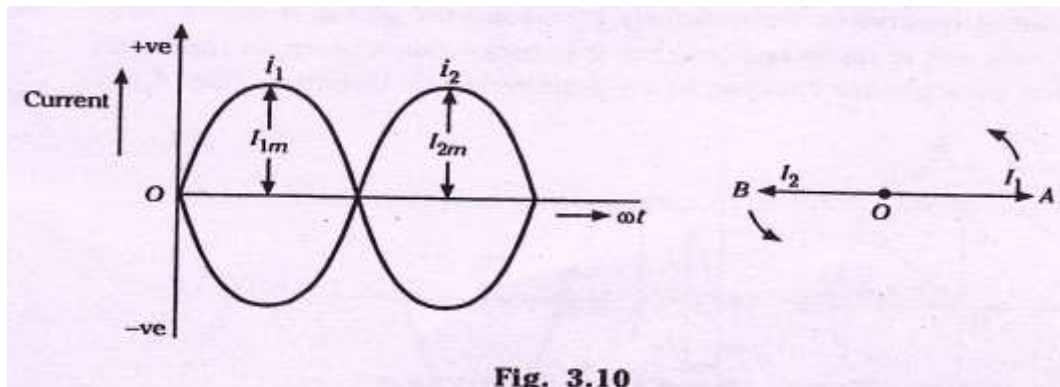
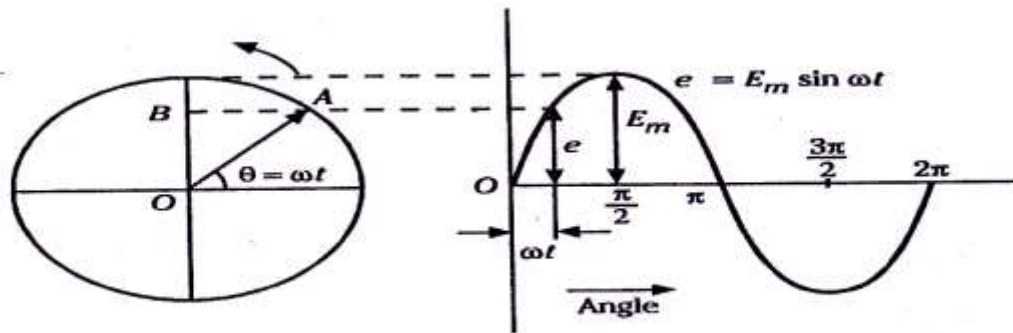

Fig. 3.10

### Phasor Representation of Alternating Quantities

We know that an alternating voltage or current has sine waveform, and generators are designed to give e.m.f.s. with the sine waveforms. The method of representing alternating quantities continuously by equation giving instantaneous values (like  $e = E_m \sin \omega t$ ) is quite

tedious. So, it is more convenient to represent a sinusoidal quantity by a phasor rotating in an anticlockwise direction (Fig.3.12).



**Fig. 3.12**

While representing an alternating quantity by a phasor, the following points are to be kept in mind:

- i) The length of the phasor should be equal to the maximum value of the alternating quantity.
- ii) The phasor should be in the horizontal position at the alternating quantity is zero and is increasing in the positive direction.
- iii) The inclination of the line with respect to some axis of reference gives the direction of that quantity and an arrow-head placed at one end indicates the direction in which that quantity acts.
- iv) The angular velocity in an anti-clockwise direction of the phasor should be such that it completes one revolution in the same time as taken by the alternating quantity to complete one cycle.

Consider phasor  $OA$ , which represents the maximum value of the alternating e.m.f. and its angle with the horizontal axis gives its phase (Fig.3.12). now, it will be seen that the projection of this phasor  $OA$  on the vertical axis will give the instantaneous value of e.m.f.

$$\therefore OB = OA \sin \omega t$$

$$\text{Or } e = OA \sin \omega t$$

$$= E_m \sin \omega t$$

Note: The term 'phasor' is also known as 'vector'.

$$a) 8+j6 = \sqrt{8^2+6^2} \angle \tan^{-1} 0.75 = 10 \angle 36.9^\circ$$

$$b) -10-j7.5 = \sqrt{(-10)^2 + (-7.5)^2} \angle \tan^{-1} 0.75 \\ = 12.5 \angle \tan^{-1} 0.75$$



This vector also falls in the third quadrant, so, following the same reasoning as mentioned in method 1, the angle when measured in CCW direction is

$$\begin{aligned} &= (180^\circ + \tan^{-1} 0.75) \\ &= 180^\circ + 36.9^\circ = 216.9^\circ \end{aligned}$$

Measured in CCW direct from +ve co-ordinate of x-axis, the angle is

$$- (360^\circ - 216.9^\circ) = -143.1^\circ$$

So this expression is written as  $12.5 \angle -143.1^\circ$

So, expression (ii) is rewritten as

$$10 \angle 36.9^\circ \times 12.5 \angle -143.1^\circ$$

**$125 \angle -106.2^\circ$**  which is the same as before.

### A.C. circuits

The path for the flow of alternating current is called on a.c. circuit.

In a d.c. circuit, the current/flowing through the circuit is given by the simple relation  $I = \frac{V}{R}$ . However, in an a.c. circuit, voltage and current change from instant to instant and so give rise to magnetic (inductive) and electrostatic (capacitive) effects. So, in an a.c. circuit, inductance and capacitance must be considered in addition to resistance.

We shall now deal with the following a.c. circuits:

- i) AC circuit containing pure ohmic resistance only.
- ii) AC circuit containing pure inductance only.
- iii) AC circuit containing pure capacitance only.

#### **AC circuit containing pure ohmic Resistance**

When an alternating voltage is applied across a pure ohmic resistance, electrons (current) flow in one direction during the first half-cycle and in the opposite direction during the next half-cycle, thus constituting alternating current in the circuit.

Let us consider an a.c. circuit with just a pure resistance  $R$  only, as shown in Fig.3.31.

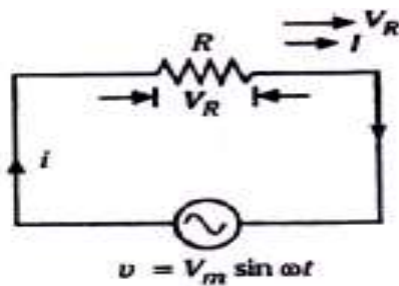

**Fig. 3.31**

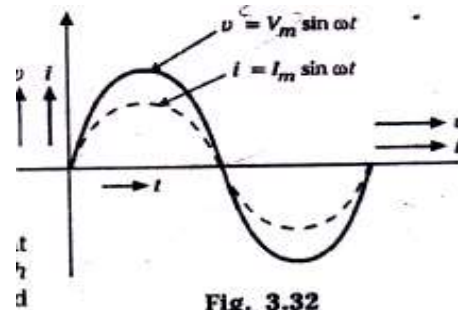

Let the applied voltage be given by the equation

$$v = V_m \sin \theta = V_m \sin \omega t \quad \text{--- (i)}$$

As a result of this alternating voltage, alternating current 'i' will flow through the circuit.

The applied voltage has to supply the drop in the resistance, i.e.,

$$v = iR$$

Substituting the value of 'v' from eqn. (i), we get

$$V_m \sin \omega t = iR \quad \text{or } i = \frac{V_m}{R} \sin \omega t \quad \text{--- (ii)}$$

The value of the alternating current 'i' is maximum when  $\sin \omega t = 1$ ,

$$\text{i.e., } I_m = \frac{V_m}{R}$$

∴ Eqn.(ii) becomes,

$$i = I_m \sin \omega t \quad \text{--- (iii)}$$

From eqns.(i) and (ii), it is apparent that voltage and current are in phase with each other. This is also indicated by the wave and vector diagram shown in Fig. 3.32.

**Power:** The voltage and current are changing at every instant.

$$\therefore \text{ Instantaneous power, } P = V_m \sin \omega t \cdot I_m \sin \omega t$$

$$= V_m I_m \sin^2 \omega t$$

$$= V_m I_m \frac{(1 - \cos 2\omega t)}{2}$$

$$= \frac{V_m I_m}{2} - \frac{V_m I_m}{2} \cos 2\omega t$$

Thus instantaneous power consists of a constant part  $\frac{V_m I_m}{2}$  and a fluctuating part  $\frac{V_m I_m}{2} \cos 2\omega t$  of frequency double that of voltage and current waves. The average value of  $\frac{V_m I_m}{2} \cos 2\omega t$  over a complete cycle is zero.

So, power for the complete cycle is

$$P = \frac{V_m I_m}{2} = \frac{V_m}{\sqrt{2}} \times \frac{I_m}{\sqrt{2}}$$

or  $P = VI$  watts

Where  $V$  = r.m.s. value of applied voltage

$I$  = r.m.s. value of the current

**Power curve**

The power curve for a purely resistive circuit is shown in Fig. 3.33. It is apparent that power in such a circuit is zero only at the instants a,b and c, when both voltage and current are zero, but is positive at all other instants. In other words, power is never negative, so that power is always lost in a resistive a.c. circuit. This power is dissipated as heat.

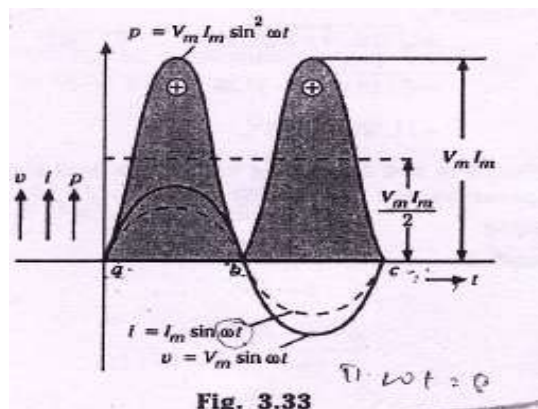
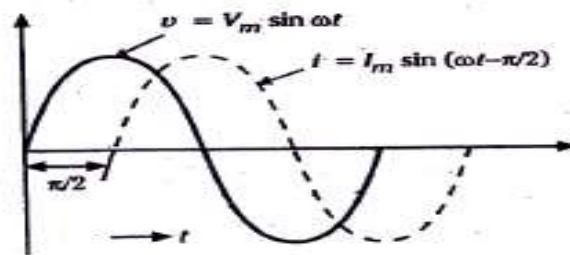

Fig. 3.33

**A.C. circuit containing pure Inductance**

An inductive coil is a coil with or without an iron core and has negligible resistance. In practice, pure inductance can never be had as the inductive coil has always a small resistance. However, a coil of thick copper wire wound on a laminated iron core has negligible resistance, so, for the purpose of our study, we will consider a purely inductive coil.

On the application of an alternating voltage (Fig.3.34) to a circuit containing a pure inductance, a back e.m.f. is produced due to the self-inductance of the coil. This back e.m.f. opposes the rise or fall of current, at every stage. Because of the absence of voltage drop, the applied voltage has to overcome this self-induced e.m.f. only.



**Fig. 3.35**

**Inductive Reactance:**  $\omega L$  in the expression  $I_m = \frac{V_m}{\omega L}$  is known as inductive reactance and is denoted by  $X_L$ , i.e.,  $X_L = \omega L$ . If 'L' is in henry and ' $\omega$ ' is in radians per second, then  $X_L$  will be in ohms. So, inductive reactance plays the part of resistance.

**Power:** Instantaneous Power,

$$\begin{aligned} P &= v \times i = V_m \sin \omega t \cdot I_m \sin \omega t \\ &= -V_m I_m \sin \omega t \cos \omega t \\ &= \frac{-V_m I_m}{2} \sin 2 \omega t \end{aligned}$$

The power measured by a wattmeter is the average value of 'p', which is zero since average of a sinusoidal quantity of double frequency over a complete cycle is zero. Put in mathematical terms,

$$\text{Power for the whole cycle, } P = -\frac{V_m I_m}{2} \int_0^{2\pi} \sin 2 \omega t \, dt = 0$$

Hence, power absorbed in a pure inductive circuit is zero.

**Power curve**

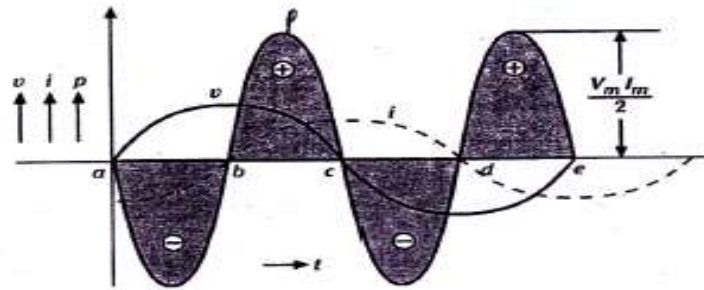

**Fig. 3.36**

The power curve for a pure inductive circuit is shown in Fig. 3.36. This indicates that power absorbed in the circuit is zero. At the instants a, c and e, voltage is zero, so that power is zero: it is also zero at points b and d when the current is zero. Between a and b voltage and current are in opposite directions, so that power is negative and energy is taken from the circuit. Between b and c voltage and current are in the same direction, so that power is positive and is put back into the circuit. Similarly, between c and d, power is taken from the circuit and between d and e it is put into the circuit. Hence, net power is zero.

**AC circuit containing pure capacitance**

When an alternating voltage is applied across the plates of a capacitor, the capacitor is charged in one direction and then in the opposite direction as the voltage reverses. With reference to Fig. 3.38,

Let alternating voltage represented by  $v = V_m \sin \omega t$  be applied across a capacitor of capacitance C Farads.

Instantaneous charge,  $q = cv = CV_m \sin \omega t$

Capacitor current is equal to the rate of change of charge, or

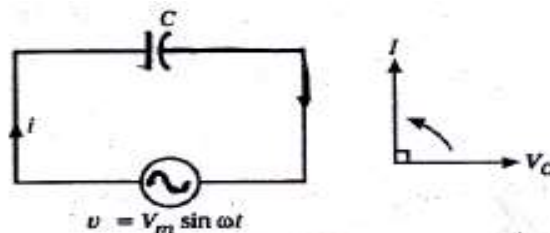

**Fig. 3.38**

$$i = \frac{dq}{dt} = \frac{d}{dt} (CV_m \sin \omega t)$$

$$= \omega CV_m \cos \omega t$$

$$\text{or } i = \frac{V_m}{\frac{1}{\omega C}} \sin \omega t$$

The current is maximum when  $t = 0$

$$\therefore I_m = \frac{V_m}{\frac{1}{\omega C}}$$

Substituting  $\frac{V_m}{\frac{1}{\omega C}} = I_m$  in the above expression for instantaneous current, we get

$$i = I_m \sin \omega t$$

**Capacitive Reactance:**  $\frac{1}{\omega C}$  in the expression  $I_m = \frac{V_m}{\frac{1}{\omega C}}$  is known as capacitive reactance and is denoted by  $X_c$ .

$$\text{i.e., } X_c = \frac{1}{\omega C}$$

If  $C$  is farads and ' $\omega$ ' is in radians, then  $X_c$  will be in ohms.

It is seen that if the applied voltage is given by  $v = V_m \sin \omega t$ , then the current is given by  $i = I_m \sin \omega t$  this shows that the current in a pure capacitor leads its voltage by a quarter cycle as shown in Fig. 3.39, or phase difference between its voltage and current is  $\frac{\pi}{2}$  with the current leading.

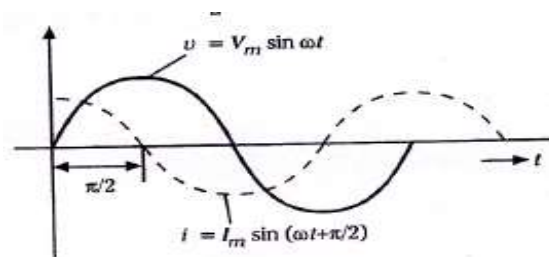

Fig. 3.39

**Power:** Instantaneous Power,

$$\begin{aligned}
 P &= vi \\
 &= V_m \sin \omega t \cdot I_m \sin \omega t \\
 &= V_m I_m \sin \omega t \cos \omega t \\
 &= \frac{1}{2} V_m I_m \int_0^{2\pi} \sin 2\omega t
 \end{aligned}$$

Power for the complete cycle

$$= \frac{1}{2} V_m I_m \int_0^{2\pi} \sin 2\omega t \, dt = 0$$

Hence power absorbed in a capacitive circuit is zero.

**Power curves** (Fig. 3.40)

At the instants b,d, the current is zero, so that power is zero; it is also zero at the instants a,c and e, when the voltage is zero. Between a and b, voltage and current are in the same direction, so that power is positive and is being put back in the circuit. Between b and c, voltage and current are in the opposite directions, so that power is negative and energy is taken from the circuit. Similarly, between c and d, power is put back into the circuit, and between d and e it is taken from the circuit.

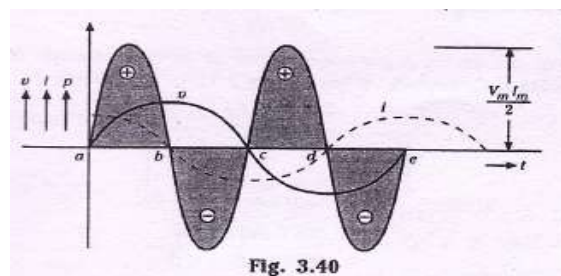

Fig. 3.40

Therefore, power absorbed in a pure capacitive circuit is zero.

**Series R-L circuit**

Let us consider an a.c. circuit containing a pure resistance R ohms and a pure inductance of L henrys, as shown in Fig. 3.43.

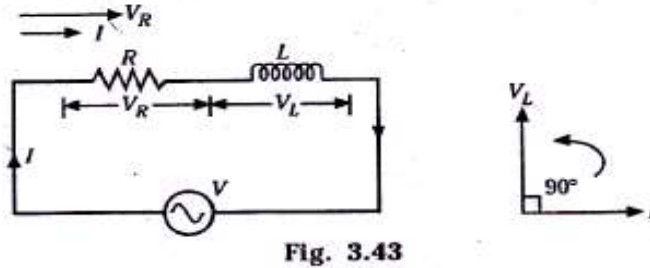

Fig. 3.43

Let V = r.m.s. value of the applied voltage

I = r.m.s. value of the current

Voltage drop across R,  $V_R = IR$  (in phase with I)

Voltage drop across L,  $V_L = IX_L$  (leading I by  $90^\circ$ )

The voltage drops across these two circuit components are shown in Fig. 3.44, where vector OA indicates  $V_R$  and AB indicates  $V_L$ . The applied voltage V is the vector sum of the two, i.e., OB.

$$\begin{aligned} \therefore V &= \sqrt{V_R^2 + V_L^2} = \sqrt{(IR)^2 + (IX_L)^2} \\ &= I \sqrt{R^2 + X_L^2} \\ \therefore I &= \frac{V}{\sqrt{R^2 + X_L^2}} \end{aligned}$$

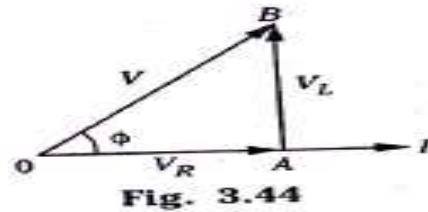

Fig. 3.44

The term  $\sqrt{R^2 + X_L^2}$  offers opposition to current flow and is called the impedance (Z) of the circuit. It is measured in ohms.

$$\therefore I = \frac{V}{Z}$$

Referring to the impedance triangle ABC, (Fig. 3.45)

$$Z^2 = R^2 + X_L^2$$

or (impedance)<sup>2</sup> + (reactance)<sup>2</sup>

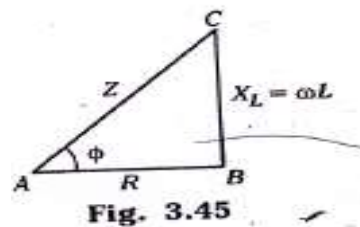
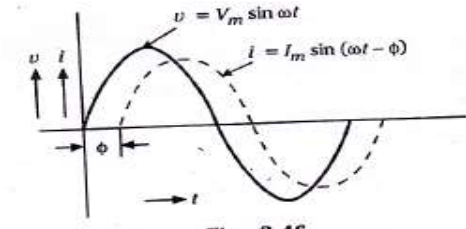

Fig. 3.45



Referring back to Fig. 3.44, we observe that the applied voltage  $V$  leads the current  $I$  by an angle  $\phi$ .



$$\tan \phi = \frac{V_L}{V_R} = \frac{I X_L}{I R} = \frac{X_L}{R} = \frac{\omega L}{R} = \frac{\text{reactance}}{\text{resistance}}$$

$$\therefore \phi = \tan^{-1} \frac{X_L}{R}$$

The same feature is shown by means of waveforms (Fig. 3.46). We observe that circuit current lags behind applied voltage by an angle  $\phi$ .

So, if applied voltage is expressed as  $v = V_m \sin \omega t$ , the current is given by  $i = I_m(\sin \omega t - \phi)$ ,  
Where  $I_m = \frac{V_m}{Z}$ .

**Definition of Real power, Reactive Power, Apparent power and power Factor**

Let a series R-L circuit draw a current  $I$  (r.m.s. value) when an alternating voltage of r.m.s. value  $V$  is applied to it. Suppose the current lags behind the applied voltage by an angle  $\phi$  as shown in Fig. 3.47.

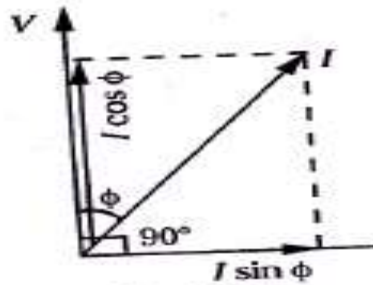

**Power Factor and its signifies**

Power Factor may be defined as the cosine of the angle of lead or lag. In Fig. 3.47, the angle of lag is shown.

Thus power Factor =  $\cos \phi$ .

In addition to having a numerical value, the power factor of a circuit carries a notation that signifies the nature of the circuit, i.e., whether the equivalent circuit is resistive, inductive or capacitive. Thus, the p.f. might be expressed as 0.8 lagging. The lagging and leading refers to the phase of the current vector with respect to the voltage vector. Thus, a lagging power factor

means that the current lags the voltage and the circuit is inductive in nature. However, in the case of leading power factor, the current leads the voltage and the circuit is capacitive.

**Apparent Power:** The product of r.m.s. values of current and voltage,  $VI$ , is called the apparent power and is measured in volt-amperes (VA) or in kilo-volt amperes (KVA).

**Real Power:** The real power in an a.c. circuit is obtained by multiplying the apparent power by the factor and is expressed in watts or killo-watts (kW).

$$\text{Real power (W)} = \text{volt-amperes (VA)} \times \text{power factor } \cos \phi$$

$$\text{or } \mathbf{Watts = VA \cos \phi}$$

Here, it should be noted that power consumed is due to ohmic resistance only as a pure inductance does not consume any power.

$$\text{Thus, } P = V I \cos \phi$$

$$\cos \phi = \frac{R}{Z} \text{ (refer to the impedance triangle of Fig. 3.45)}$$

$$\begin{aligned} \therefore P &= V I \times \left[ \frac{R}{Z} \right] \\ &= \left[ \frac{V}{Z} \right] \times IR = I^2 R \end{aligned}$$

$$\text{or } \mathbf{P = I^2 R \text{ watts}}$$

**Reactive Power:** It is the power developed in the inductive reactance of the circuit. The quantity  $VI \sin \phi$  is called the reactive power; it is measured in reactive volt-amperes or vars (VAr).

The power consumed can be represented by means of waveform in Fig. 3.48.

We will now calculate power in terms of instantaneous values.

$$\begin{aligned} \text{Instantaneous power, } P &= vi = V_m \sin \omega t \times I_m \sin (\omega t - \phi) \\ &= V_m I_m \sin \omega t \sin(\omega t - \phi) \\ &= \frac{1}{2} V_m I_m [\cos \phi - \cos(2\omega t - \phi)] \end{aligned}$$

This power consists of two parts:

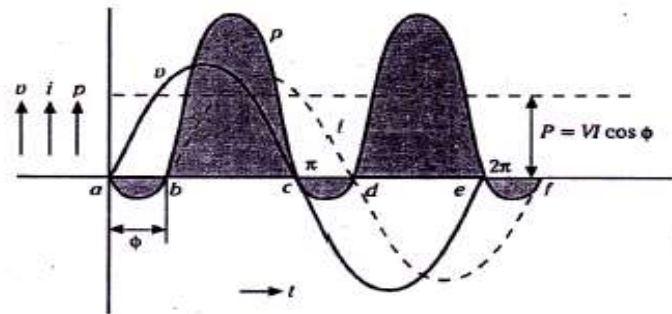

Fig. 3.48

- i) Constant part  $\frac{1}{2} V_m I_m \cos \phi$  which contributes to real power.
- ii) Sinusoidally varying part  $\frac{1}{2} V_m I_m \cos (2\omega t - \phi)$ , whose frequency is twice that of the voltage and the current, and whose average value over a complete cycle is zero (so it does not contribute to any power).

So, average power consumed,  $P = \frac{1}{2} V_m I_m \cos \phi$

$$= \frac{V_m}{\sqrt{2}} \cdot \frac{I_m}{\sqrt{2}} \cos \phi$$

$$= \mathbf{V I \cos \phi}$$

Where V and I are r.m.s. values

### Power curves:

The power curve for R-L series circuit is shown in Fig. 3.48. The curve indicates that the greater part is positive and the smaller part is negative, so that the net power over the cycle is positive.

During the time interval a to b, applied voltage and current are in opposite directions, so that power is negative. Under such conditions, the inductance L returns power to the circuit. During the period b to c, the applied voltage and current are in the same direction so that power is positive, and therefore, power is put into the circuit. In a similar way, during the period c to d, inductance L returns power to the circuit while between d and e, power is put into the circuit. The power absorbed by resistance R is converted into heat and not returned.

Series R – C circuit

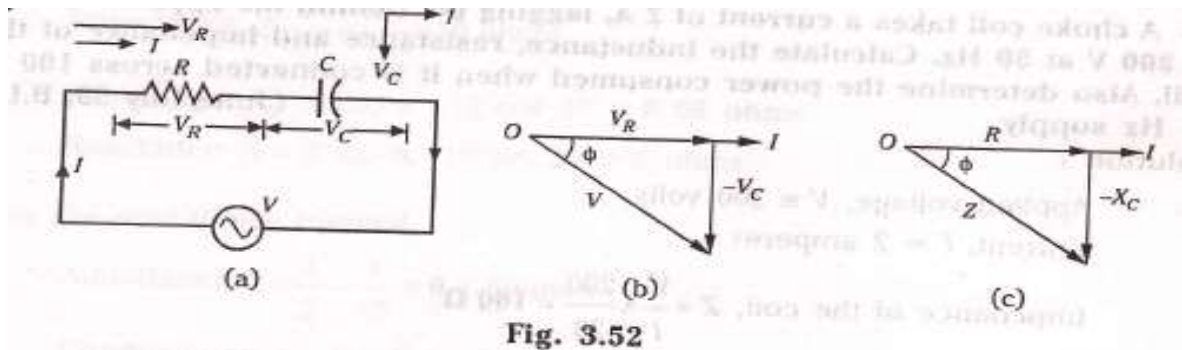

Fig. 3.52

Consider an a.c. circuit containing resistance R ohms and capacitance C farads, as shown in the fig. 3.52(a).

Let V = r.m.s. value of voltage

I = r.m.s. value of current

- ∴ voltage drop across R,  $V_R = IR$  - in phase with I
- Voltage drop across C,  $V_C = IX_C$  - lagging I by  $\frac{\pi}{2}$

The capacitive resistance is negative, so  $V_C$  is in the negative direction of Y – axis, as shown in the fig. 3.52(b).

$$\begin{aligned} \text{We have } V &= \sqrt{V_R^2 + (-V_C)^2} = \sqrt{(IR)^2 + (-IX_C)^2} \\ &= \sqrt{R^2 + X_C^2} \end{aligned}$$

$$\text{Or } I = \frac{V}{\sqrt{R^2 + X_C^2}} = \frac{V}{Z}$$

The denominator, Z is the impedance of the circuit, i.e.,  $Z = \sqrt{R^2 + X_C^2}$ . fig. 3.52(c) depicts the impedance triangle.

$$\text{Power factor, } \cos\phi = \frac{R}{Z}$$

Fig. 3.52(b) shows that I leads V by an

$$\text{angle } \phi, \text{ so that } \tan\phi = \frac{-X_C}{R}$$

This implies that if the alternating voltage is  $v = V_m \sin\omega t$ , the resultant current in the R – C circuit is given by

$i = I_m \sin(\omega t + \phi)$ , such that current leads the applied voltage by the angle  $\phi$ . The waveforms of fig. 3.53 depict this.

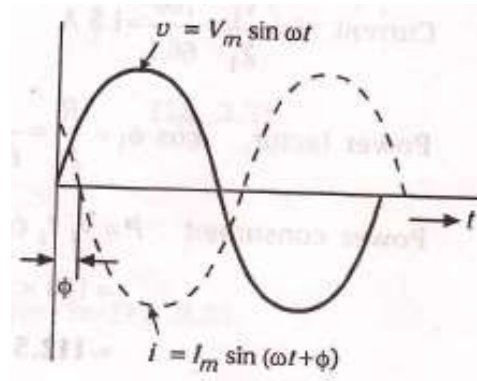

Fig. 3.53

**Power:** Average power,  $P = v \times I = VI \cos \phi$  (as in sec. 3.17).

**Power curves:** The power curve for R – C series circuit is shown in fig. 3.54. The curve indicates that the greater part is positive and the smaller part is negative, so that the net power is positive.

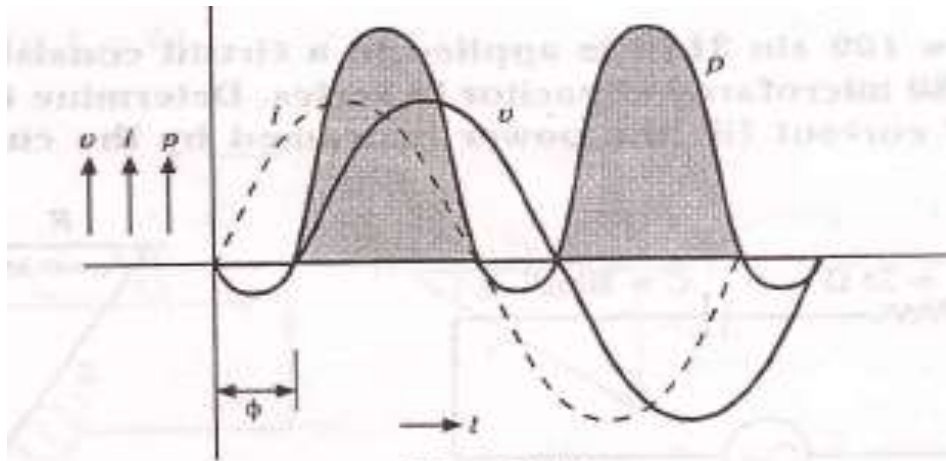

Fig. 3.54

**Resistance, Inductance and capacitance in series (RLC – Series Circuit)**

Consider an a.c. series circuit containing resistance R ohms, Inductance L henries and capacitance C farads, as shown in the fig. 3.59.

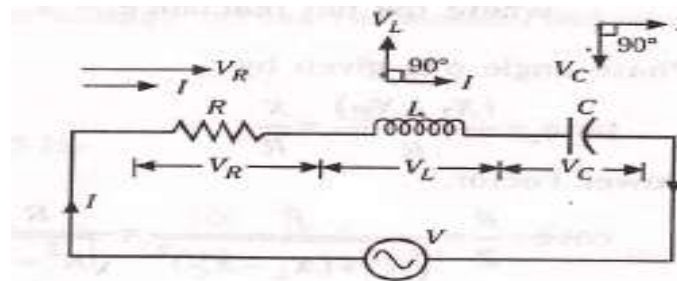

Fig. 3.59

Let  $V$  = r.m.s. value of applied voltage

$I$  = r.m.s. value of current

- $\therefore$  Voltage drop across R,  $V_R = IR$  - in phase with  $I$
- voltage drop across L,  $V_L = I.X_L$  - lagging  $I$  by  $90^\circ$
- Voltage drop across C,  $V_C = I.X_C$  - lagging  $I$  by  $90^\circ$

Referring to the voltage triangle of Fig. 3.60, OA represents  $V_R$ , AB and AC represent inductive and capacitive drops respectively. We observe that  $V_L$  and  $V_C$  are  $180^\circ$  out of phase.

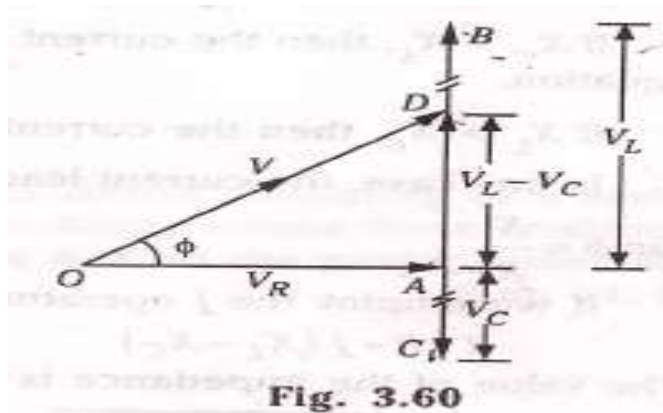

Thus, the net reactive drop across the combination is

$$\begin{aligned}
 AD &= AB - AC \\
 &= AB - BD (\because BD = AC) \\
 &= V_L - V_C \\
 &= I(X_L - X_C)
 \end{aligned}$$

OD, which represents the applied voltage  $V$ , is the vector sum of OA and AD.

$$\begin{aligned}
 \therefore OD &= \sqrt{OA^2 + AD^2} \quad \text{OR} \quad V = \sqrt{(IR)^2 + (IX_L - IX_C)^2} \\
 &= I\sqrt{R^2 + (X_L - X_C)^2}
 \end{aligned}$$

$$\text{Or } I = \frac{V}{\sqrt{R^2 + (X_L - X_C)^2}} = \frac{V}{\sqrt{R^2 + X^2}} = \frac{V}{Z}$$

The denominator  $\sqrt{R^2 + (X_L - X_C)^2}$  is the impedance of the circuit.

So (impedance)<sup>2</sup> = (resistance)<sup>2</sup> + (net reactance)<sup>2</sup>

$$\text{Or } Z^2 = R^2 + (X_L - X_C)^2 = R^2 + X^2$$

Where the net reactance = X (fig. 3.61)

Phase angle  $\phi$  is given by

$$\tan\phi = \frac{(X_L - X_C)}{R} = \frac{X}{R}$$

power factor,

$$\cos\phi = \frac{R}{Z} = \frac{R}{\sqrt{R^2 + (X_L - X_C)^2}} = \frac{R}{\sqrt{R^2 + X^2}}$$

Power = VI cos  $\phi$

If applied voltage is represented by the equation  $v = V_m \sin\omega t$ , then the resulting current in an R – L – C circuit is given by the equation

$$i = I_m \sin(\omega t \pm \phi)$$

If  $X_C > X_L$ , then the current leads and the +ve sign is to be used in the above equation.

If  $X_L > X_C$ , then the current lags and the –ve sign is to be used.

If any case, the current leads or lags the supply voltage by an angle  $\phi$ , so that  $\tan\phi = \frac{X}{R}$ .

If we employ the j operator (fig. 3.62), then we have

$$Z = R + j(X_L - X_C)$$

The value of the impedance is

$$Z = \sqrt{R^2 + (X_L - X_C)^2}$$

The phase angle  $\phi = \tan^{-1} \frac{(X_L - X_C)}{R}$

$$Z \angle \phi = Z \angle \tan^{-1} \left[ \frac{X_L - X_C}{R} \right]$$

$$= Z \angle \tan^{-1} \left[ \frac{X}{R} \right]$$

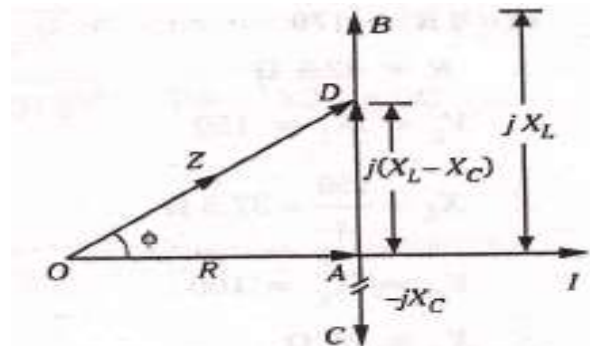

Fig. 3.62

### Parallel AC circuits

In a parallel a.c. circuit, the voltage across each branch of the circuit is the same whereas current in each branch depends upon the branch impedance. Since alternating currents are vector quantities, total line current is the vector sum of branch currents.

The following are the three methods of solving parallel a.c. circuits:

- Vector method.
- Admittance method.

c) Symbolic or j- method.

### 3.20.1 Vector method

In this method the total line current is found by drawing the vector diagram of the circuit. As voltage is common, it is taken as the reference vector and the various branch currents are represented vectorially. The total line current can be determined from the vector diagram either by the parallelogram method or by the method of components.

#### Branch 1

$$\text{Impedance } Z_1 = \sqrt{R_1^2 + X_L^2}$$

$$\text{Current } I_1 = \frac{V}{Z_1}$$

$$\cos \phi_1 = \frac{R_1}{Z_1} \quad \text{or} \quad \phi_1 = \cos^{-1} \left( \frac{R_1}{Z_1} \right)$$

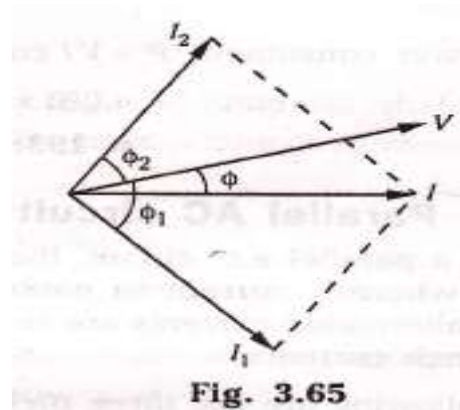

Current  $I_1$  lags behind the applied voltage by  $\phi$  (fig. 3.65).

#### Branch 2

$$\text{Impedance } Z_2 = \sqrt{R_2^2 + X_C^2}$$

$$\text{Current } I_2 = \frac{V}{Z_2}$$

$$\cos \phi_2 = \frac{R_2}{Z_2} \quad \text{or} \quad \phi_2 = \cos^{-1} \left( \frac{R_2}{Z_2} \right)$$

Current  $I_2$  leads  $V$  by  $\phi_2$  (fig. 3.65).

**Resultant current :** The total line current  $I$  is the vector sum of the branch currents  $I_1$  and  $I_2$  and is found by using the parallelogram law of vectors, as shown in fig. 3.65.

The second method is the method of components i.e., resolving the branch currents  $I_1$  and  $I_2$  along the x- axis and y- axis and then finding the resultant of these components (fig. 3.66).

Let the resultant current be  $I$  and  $\phi$  be its phase angle, as shown in fig. 3.66 (b). Then the components of  $I$  along X- axis is equal to the algebraic sum of the components of branch currents  $I_1$  and  $I_2$  along the X- axis (active components).



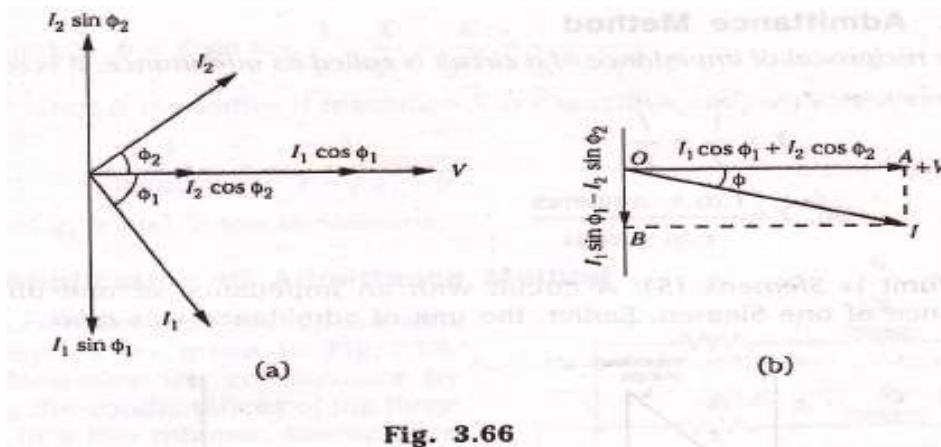

Similarly, the component of I along Y- axis is equal to the algebraic sum of the components of  $I_1$  and  $I_2$  along Y- axis i.e,

Component of resultant current along Y- axis

= algebraic sum of  $I_1$  and  $I_2$  along X – axis

or  $I \cos \phi = I_1 \cos \phi_1 + I_2 \cos \phi_2$

Component of resultant current along Y – axis

= algebraic sum of  $I_1$  and  $I_2$  along Y – axis

or  $I \sin \phi = I_1 \sin \phi_1 - I_2 \sin \phi_2$

$$\begin{aligned} \therefore I &= \sqrt{(I \cos \phi)^2 + (I \sin \phi)^2} \\ &= \sqrt{(I_1 \cos \phi_1 + I_2 \cos \phi_2)^2 + (I_1 \sin \phi_1 - I_2 \sin \phi_2)^2} \end{aligned}$$

$$\text{and } \tan \phi = \frac{I_1 \sin \phi_1 - I_2 \sin \phi_2}{I_1 \cos \phi_1 + I_2 \cos \phi_2}$$

If  $\tan \phi$  is positive, current leads and if  $\tan \phi$  is negative, then the current lags behind applied voltage V. power factor for the entire circuit

$$\cos \phi = \frac{I_1 \cos \phi_1 + I_2 \cos \phi_2}{I}$$

### Admittance Method

The reciprocal of impedance of a circuit is called its admittance. It is represented by Y.

$$Y = \frac{1}{Z} = \frac{1}{V}$$

$$\text{So, } Y = \frac{\text{r.m.s. amperes}}{\text{r.m.s volts}}$$

Its unit is Siemens (S). A circuit with an impedance of one ohm has an admittance of one siemen. Earlier, the unit of admittance was mho.

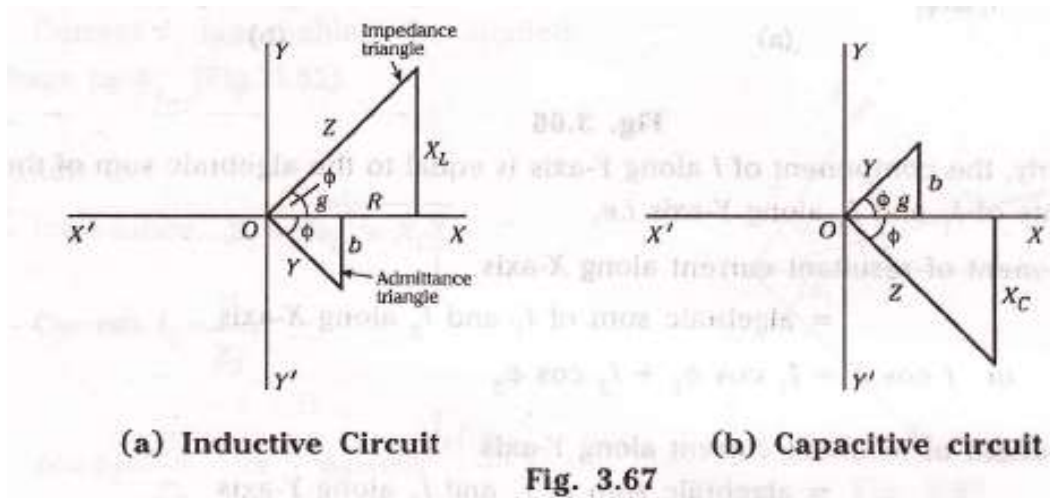

Just as impedance  $Z$  of a circuit had two rectangular components, resistance  $R$  and reactance  $X$ , admittance  $Y$  also has two rectangular components known as conductance  $g$  and susceptance  $b$ . fig. 3.67 shows the impedance triangle and the admittance triangle. It is clear the admittance has two components  $g$  and  $b$ . The component  $g$  along the  $X$ - axis is the conductance which is the reciprocal of resistance. The component  $b$  is called susceptance, which is the reciprocal of reactance.

In fig. 3.67(a), the impedance and admittance triangles for an inductive circuit are shown. It is apparent that susceptance  $b$  is negative, being below  $X$  – axis. Hence inductive susceptance is negative. In fig. 3.67 (b), the impedance and admittance triangles for capacitive circuit is shown. It is evident that susceptance is positive, being above the  $X$  – axis; hence, capacitive susceptance is positive.

### Relations

$$\text{Conductance } g = Y \cos \phi$$

$$\text{Or } g = \frac{1}{Z} \cdot \frac{R}{Z} = \frac{R}{Z^2} = \frac{R}{R^2 + X^2}$$

Conductance is always positive.

$$\text{Susceptance } b = Y \sin \phi = \frac{1}{Z} \cdot \frac{X}{Z} = \frac{X}{Z^2} = \frac{X}{R^2 + X^2}$$

Susceptance **b** is positive if reactance **X** is capacitive and negative if reactance is inductive.

$$\text{Admittance } Y = \sqrt{g^2 + b^2}$$

The units of g, b and y are in Siemens.

**Application of admittance method**

Let us consider a parallel circuit with three branches, as given in fig. 3.68.

we can determine the conductors by just adding the conductance of the three branches. In a like manner, susceptance is determined by the algebraic addition of the susceptances of the different branches.

Total conductance,

$$G = g_1 + g_2 + g_3$$

Total susceptance

$$B = (-b_1) + (-b_2) + b_3$$

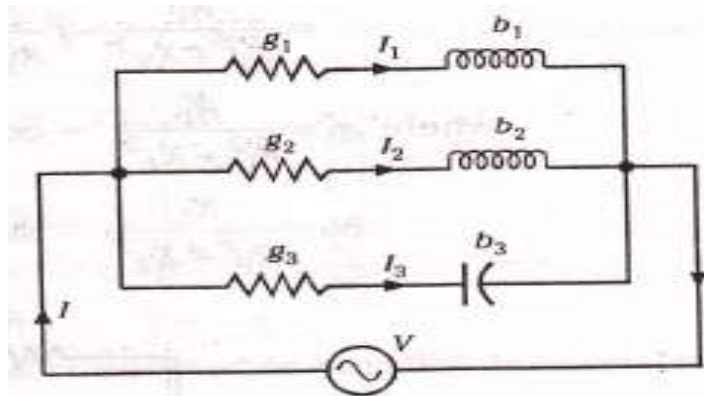

Fig. 3.68

∴ Total admittance  $Y = \sqrt{G^2 + B^2}$

Total current  $I = VY$

Power factor,  $\cos \phi = \frac{G}{Y}$

**Symbolic or j- method**

Let us take the parallel two – branch circuit of fig. 3.69, with the same p.d. across the two impedances  $Z_1$  and  $Z_2$ .

$$I_1 = \frac{V}{Z_1} \quad \text{and} \quad I_2 = \frac{V}{Z_2}$$

$$\text{Total current } I = I_1 + I_2 = \frac{V}{Z_1} + \frac{V}{Z_2} = V \left( \frac{1}{Z_1} + \frac{1}{Z_2} \right)$$

$$= V (Y_1 + Y_2)$$

$$= VY$$

Where the total admittance  $Y = Y_1 + Y_2$

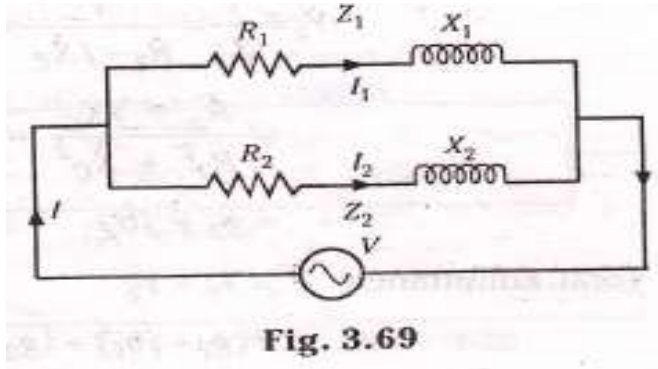

Fig. 3.69

We should note that admittances are added for parallel branches, whereas impedances are added for series branches. Both admittances and impedances are complex quantities, so all additions have to be performed in complex form.

In case of the two parallel branches of fig. 3.70,

$$Y_1 = \frac{1}{Z_1} = \frac{1}{R_1 + jX_L} = \frac{(R_1 - jX_L)}{(R_1 + jX_L)(R_1 - jX_L)} = \frac{R_1 - jX_L}{R_1^2 + X_L^2}$$

$$= \frac{R_1}{R_1^2 + X_L^2} - j \frac{X_L}{R_1^2 + X_L^2} = g_1 - jb_1$$

Where  $g_1 = \frac{R_1}{R_1^2 + X_L^2}$  ----- conductance of top branch

$b_1 = \frac{X_L}{R_1^2 + X_L^2}$  ----- susceptance of top branch

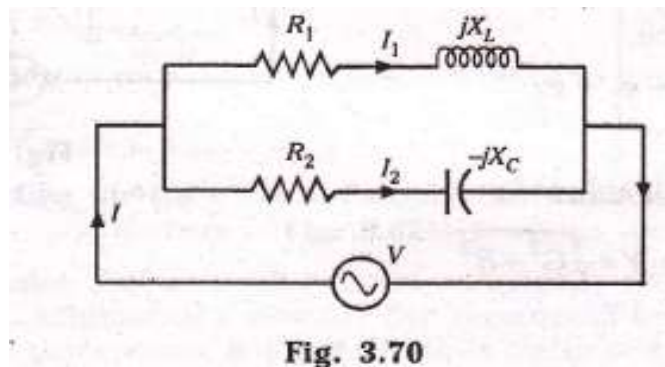

Fig. 3.70

In similar manner,

$$\begin{aligned} Y_2 &= \frac{1}{Z_2} = \frac{1}{R_2 - jX_L} = \frac{(R_2 + jX_L)}{(R_2 - jX_C)(R_2 + jX_C)} = \frac{R_2 + jX_C}{R_2^2 + X_C^2} \\ &= \frac{R_2}{R_2^2 + X_C^2} + j \frac{X_L}{R_2^2 + X_C^2} = g_2 + jb_2 \end{aligned}$$

Total admittance  $Y = Y_1 + Y_2$

$$= (g_1 - jb_1) + (g_2 + jb_2)$$

$$= (g_1 + g_2) - j(b_1 - b_2)$$

$$= G - jB$$

$$Y = \sqrt{(g_1 + g_2)^2 + (b_1 - b_2)^2}$$

$$\phi = \tan^{-1} \left[ \frac{b_1 - b_2}{g_1 + g_2} \right]$$

In polar form, admittance  $Y = Y \angle \phi^0$

$$Y = \sqrt{G^2 + B^2} \angle \tan^{-1} \left( \frac{B}{G} \right)$$

Total current  $I = VY$ ;  $I_1 = VY_1$  and  $I_2 = VY_2$

$$V = V \angle 0^0 \quad \text{and} \quad Y = Y \angle \phi$$

$$\text{So} \quad I = VY = V \angle 0^0 \times Y \angle \phi = VY \angle \phi$$

Taking a general case,

$$V = V \angle \alpha \quad \text{and} \quad Y = Y \angle \beta, \text{ then}$$

$$\text{So} \quad I = VY = V \angle \alpha \times Y \angle \beta = VY \angle \alpha + \beta$$

### **3b. Domestic Wiring:**

#### **Introduction**

A network of wires drawn connecting the meter board to the various energy consuming loads (lamps, fans, motors etc) through control and protective devices for efficient distribution of power is known as electrical wiring.

Electrical wiring done in residential and commercial buildings to provide power for lights, fans, pumps and other domestic appliances is known as domestic wiring. There are several wiring systems in practice. They can be classified into:

**Types of wiring:** Depending upon the above factors various types of wiring used in practice are:

1. Cleat wiring
2. Casing wiring
3. Surface wiring
4. Conduit wiring
- i) Clear wiring:

In this type V.I.R or P.V.C wires are clamped between porcelain cleats.

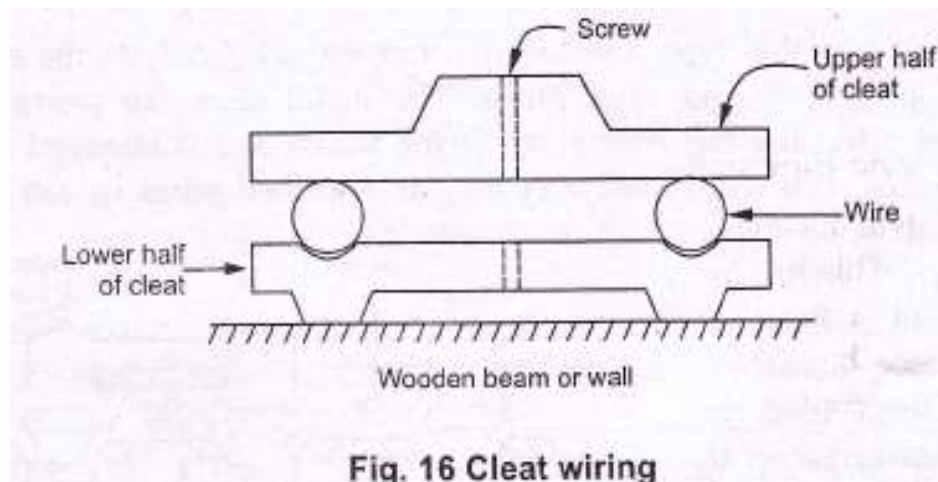

**Fig. 16 Cleat wiring**

The cleats are made up of two halves. One half is grooved through which wire passes while the other fits over the first. The whole assembly is then mounted on the wall or wooden beam with the help of screws.

This method is one of the cheapest method and most suitable for temporary work. It can be very quickly installed and can be recovered without any damage of material. Inspection and changes can be made very easily.

This method does not give attractive appearance. After some time due to sagging at some places, it looks shabby. Dust and dirt collects on the cleats. The wires are directly exposed to atmospheric conditions like moisture, chemical fumes etc. maintenance cost is very high.

Due to these disadvantages this type is not suitable for permanent jobs.

**ii) Casing capping:** This is very popularly used for residential buildings. In this method, casing is a rectangular strip made from teak wood or new a day's made up of P.V.C. It has two grooves into which the wires are laid. Then casing is covered with a rectangular strip of wood or P.V.C. of the same width, called capping. The capping is screwed into casing is fixed to the walls the help or porcelain discs or cleats.

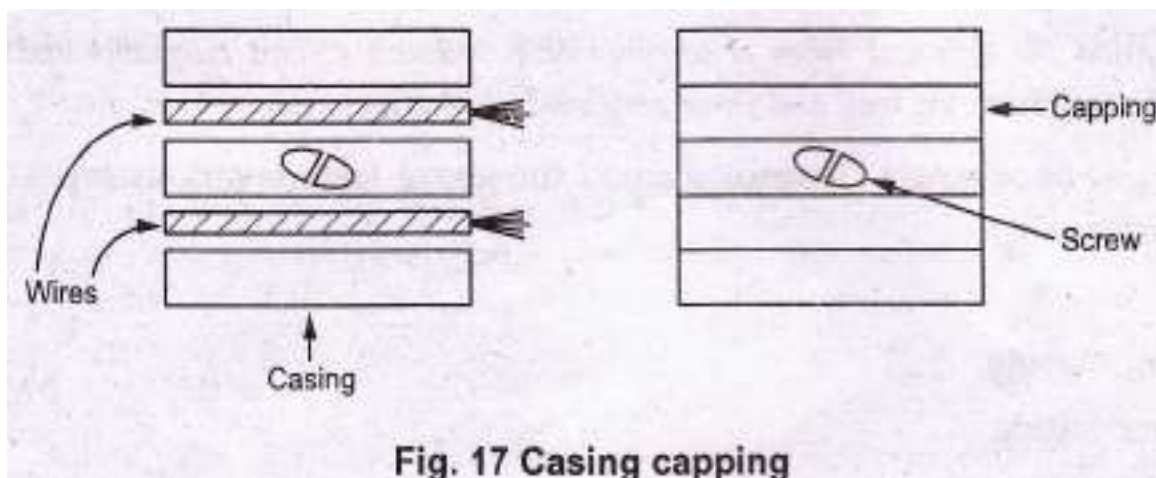
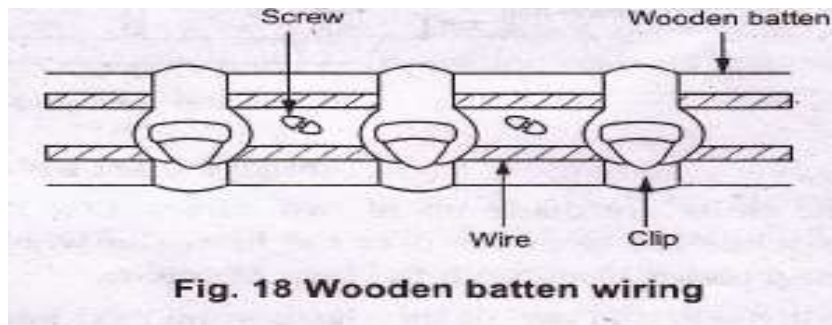

**Fig. 17 Casing capping**

Good protection to the conductors from dangerous atmospheric conditions, neat and clean appearance are the advantages of this type.

In case of wooden casing capping, there is high risk of fire along with the requirement of skilled labour. The method is costly.

**Surface wiring:** in this type, the wooden battens are fixed on the surface of the wall, by means of screws and rawl plugs. The metal clips are provided with the battens at regular intervals. The wire runs on the batten and is clamped on the batten using the metal clips. The wires used may lead sheathed wires or can tyre sheathed wires. Depending upon type of wire used surface wiring is also called lead sheathed wiring or cab tyre sheathed wiring. If the wire used is though rubber Sheathed then it is called T.R.S. wiring while if the wire used is cab tyre Sheathed Then it is called C.T.S wiring.



**Conduit wiring:** In this method, metallic tubes called as conduits are used to run the wires. This is the best system of wiring as it gives full mechanical protection to the wires. This is most desirable for workshops and public Buildings. Depending on whether the conduits are laid inside the walls or supported on the walls, there are two types of conduit wiring which are :

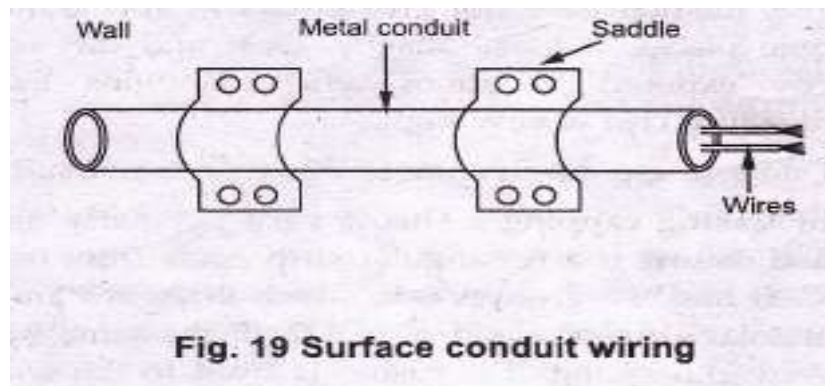



i) **Surface conduit wiring:** in this method conduits are mounted or supported on the walls with the help of pipe books or saddles. In damp situations, the conduits are spaced apart from the wall by means of wooden blocks.

ii) **Concealed conduit wiring:** In this method, the conduit are buried under the wall at the some of plastering. This is also called recessed conduit wiring.

The beauty of the premises is maintained due to conduit wiring. It is durable and has long life. It protects the wires from mechanical shocks and fire hazards. Proper earthing of conduits makes the method electrical shock proof. It requires very less maintenance.

The repairs are very difficult in case of concealed conduit wiring. This method is most costly and erection requires highly skilled labour. These are few disadvantages of the conduit type of wiring. In concealed conduit wiring, keeping conduit at earth potential is must.

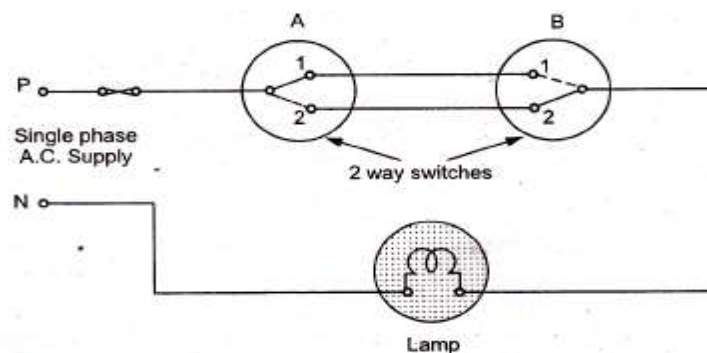

Fig. 20 Control of one from two points

### **FACTORS AFFECTING THE CHOICE OF WIRING SYSTEM:**

The choice of wiring system for a particular installation depends on technical factors and economic viability.

**1. Durability:** Type of wiring selected should conform to standard specifications, so that it is durable i.e. without being affected by the weather conditions, fumes etc.

**2. Safety:** The wiring must provide safety against leakage, shock and fire hazards for the operating personnel.

**3. Appearance:** Electrical wiring should give an aesthetic appeal to the interiors.

4. **Cost:** It should not be prohibitively expensive.
5. **Accessibility:** The switches and plug points provided should be easily accessible. There must be provision for further extension of the wiring system, if necessary.
- 6 **Maintenance Cost:** The maintenance cost should be a minimum
7. **Mechanical safety:** The wiring must be protected against any mechanical damage

### **Specification of Wires:**

The conductor material, insulation, size and the number of cores, specifies the electrical wires. These are important parameters as they determine the current and voltage handling capability of the wires. The conductors are usually of either copper or aluminum. Various insulating materials like PVC, TRS, and VIR are used. The wires may be of single strand or multi strand. Wires with combination of different diameters and the number of cores or strands are available.

For example: The VIR conductors are specified as 1/20, 3/22,....7/20 .....

The numerator indicates the number of strands while the denominator corresponds to the diameter of the wire in SWG (Standard Wire Gauge). SWG 20 corresponds to a wire of diameter 0.914mm, while SWG 22 corresponds to a wire of diameter 0.737 mm.

A 7/0 wire means, it is a 7-cored wire of diameter 12.7mm (0.5 inch). The selection of the wire is made depending on the requirement considering factors like current and voltage ratings, cost and application.

Example: Application: domestic wiring

1. Lighting - 3/20 copper wire
2. Heating - 7/20 copper wire

The enamel coating (on the individual strands) mutually insulates the strands and the wire on the whole is provided with PVC insulation. The current carrying capacity depends on the total area of the wire. If cost is the criteria then aluminum conductors are preferred. In that case, for the same current rating much larger diameter of wire is to be used.

**Two- way and Three- way Control of Lamps:**

The domestic lighting circuits are quite simple and they are usually controlled from one point. But in certain cases it might be necessary to control a single lamp from more than one point (Two or Three different points).

For example: staircases, long corridors, large halls etc.

**Two-way Control of lamp:**

Two-way control is usually used for staircase lighting. The lamp can be controlled from two different points: one at the top and the other at the bottom - using two- way switches which strap wires interconnect. They are also used in bedrooms, big halls and large corridors. The circuit is shown in the following figure.

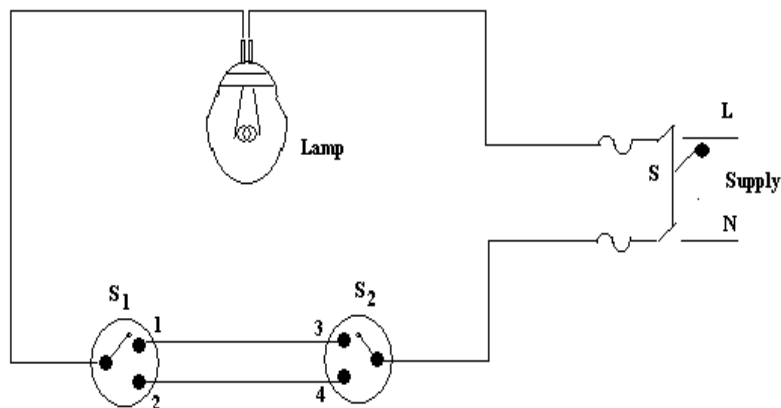

Two -way control of lamp

Switches  $S_1$  and  $S_2$  are two-way switches with a pair of terminals 1&2, and 3&4 respectively. When the switch  $S_1$  is in position 1 and switch  $S_2$  is in position 4, the circuit does not form a closed loop and there is no path for the current to flow and hence the lamp will be **OFF**. When  $S_1$  is changed to position 2 the circuit gets completed and hence the lamp glows or is **ON**. Now if  $S_2$  is changed to position 3 with  $S_1$  at position 2 the circuit continuity is broken and the lamp is off. Thus the lamp can be controlled from two different points.

Position of S1	Position of S2	Condition of lamp
1	3	ON
1	4	OFF
2	3	OFF
2	4	ON

### **Three- way Control of lamp:**

In case of very long corridors it may be necessary to control the lamp from 3 different points. In such cases, the circuit connection requires two; two-way switches  $S_1$  and  $S_2$  and an intermediate switch  $S_3$ . An intermediate switch is a combination of two, two way switches coupled together. It has 4 terminals ABCD. It can be connected in two ways

- a) Straight connection
- b) Cross connection

In case of straight connection, the terminals or points AB and CD are connected as shown in figure 1(a) while in case of cross connection, the terminals AB and

C D is connected as shown in figure 1(b). As explained in two –way control the lamp is ON if the circuit is complete and is OFF if the circuit does not form a closed loop.

Three -way control of lamp

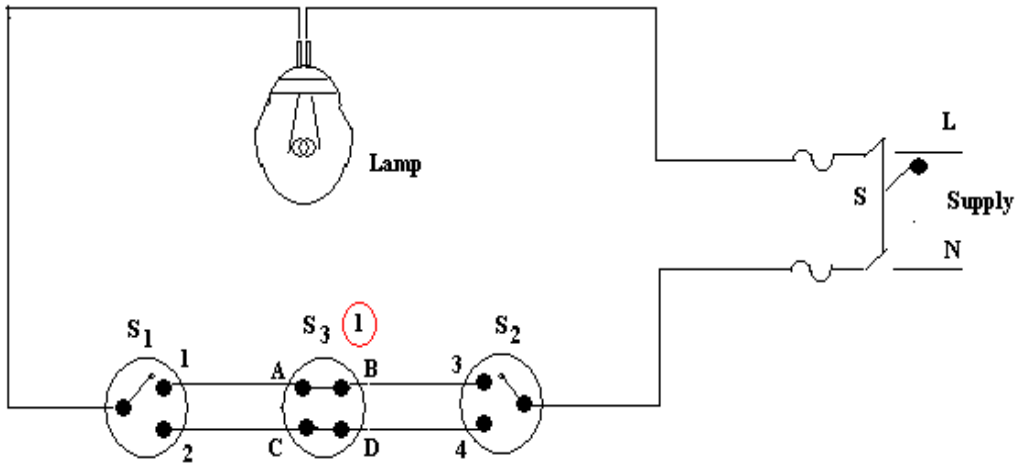

Figure 1 (a) Straight connection

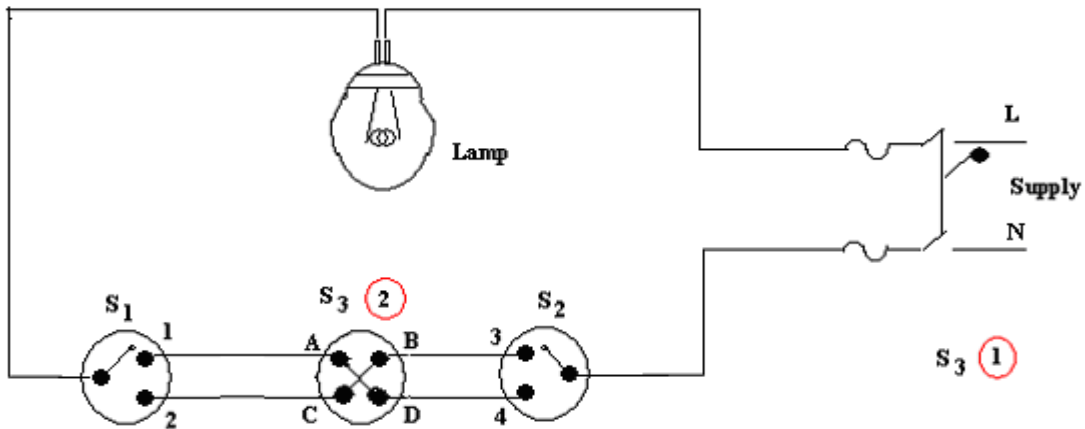

Figure 1 (b) Cross connection

The condition of the lamp is given in the table depending on the positions of the switches  $S_1$ ,  $S_2$  and  $S_3$ .

**EARTHING:**

The potential of the earth is considered to be at zero for all practical purposes as the generator (supply) neutral is always earthed. The body of any electrical equipment is connected to the earth by means of a wire of negligible resistance to safely discharge electric energy, which may be due to failure of the insulation, line coming in contact with the casing etc. Earthing brings the potential of the body of the equipment to ZERO i.e. to the earth's potential, thus protecting the operating personnel against electrical shock. The body of the electrical equipment is not connected to the supply neutral because due to long transmission lines and intermediate substations, the same neutral wire of the generator will not be available at the load end. Even if the same neutral wire is running it will have a self-resistance, which is higher than the human body resistance. Hence, the body of the electrical equipment is connected to earth only.

Thus earthing is to connect any electrical equipment to earth with a very low resistance wire, making it to attain earth's potential. The wire is usually connected to a copper plate placed at a depth of 2.5 to 3 meters from the ground level.

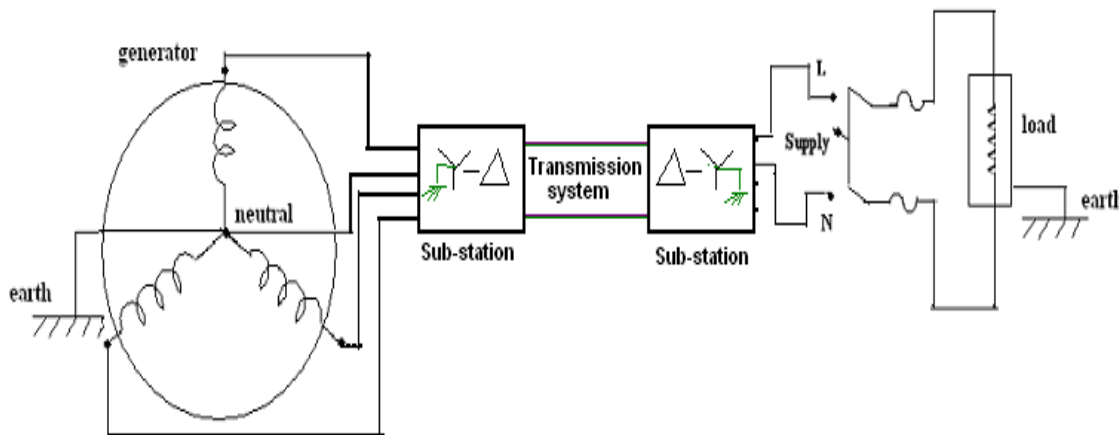
**BLOCK DIAGRAM**

The earth resistance is affected by the following factors:

1. Material properties of the earth wire and the electrode
2. Temperature and moisture content of the soil
3. Depth of the pit
4. Quantity of the charcoal used

The importance of earthing is illustrated in the following figures

Case I

Healthy insulation

Apparatus not earthed

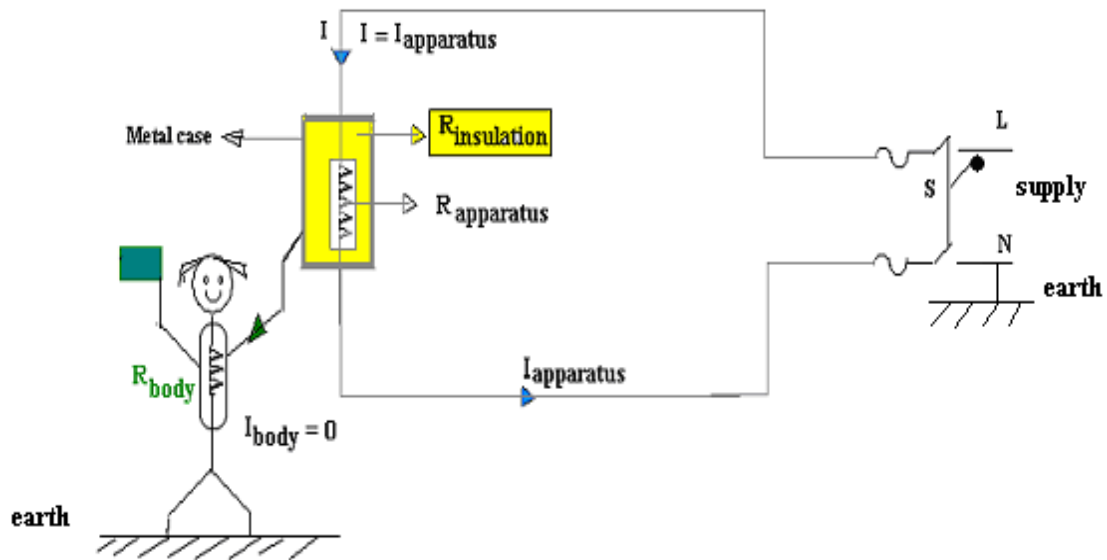

1. Insulation is healthy ( $R_{\text{insulation}} = \infty$ )
2. Supply current flows through the resistance of the apparatus only ( $R_{\text{apparatus}}$ )
3. No current flows through the body resistance ( $I_{\text{body}} = 0$ )
4. The person is safe even if the apparatus is not earthed

## Case II

Defective insulation

Apparatus not earthed

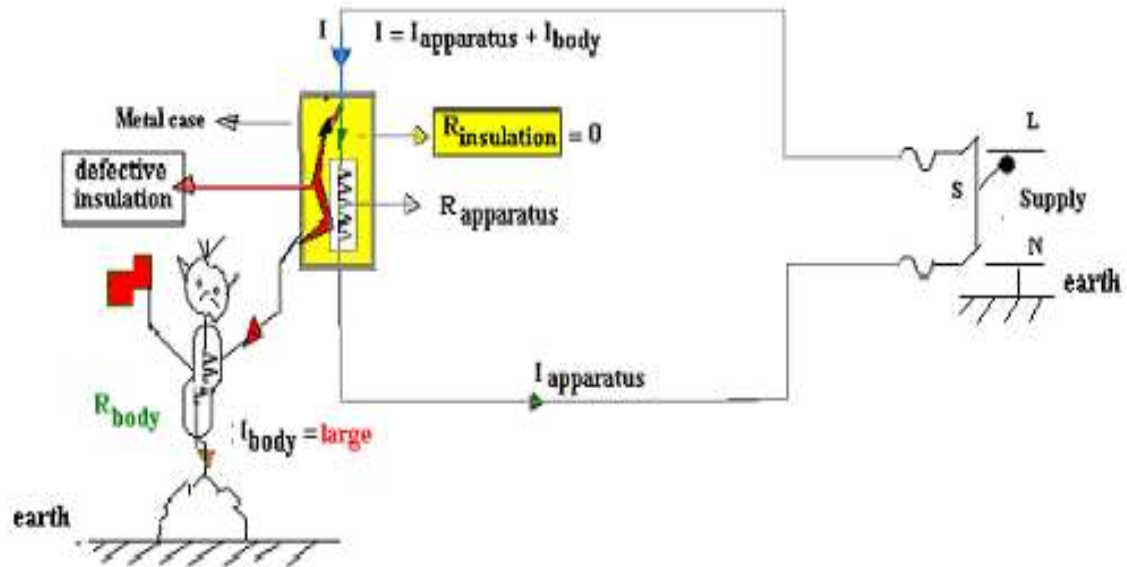

1. Insulation is bad ( $R_{\text{insulation}} = 0$ )
2. Supply current now divides into  $I_{\text{apparatus}}$  and  $I_{\text{body}}$
3. A part of the supply current flows through the body to the ground  $I_{\text{body}}$
4. The person experiences shock as the apparatus is not earthed



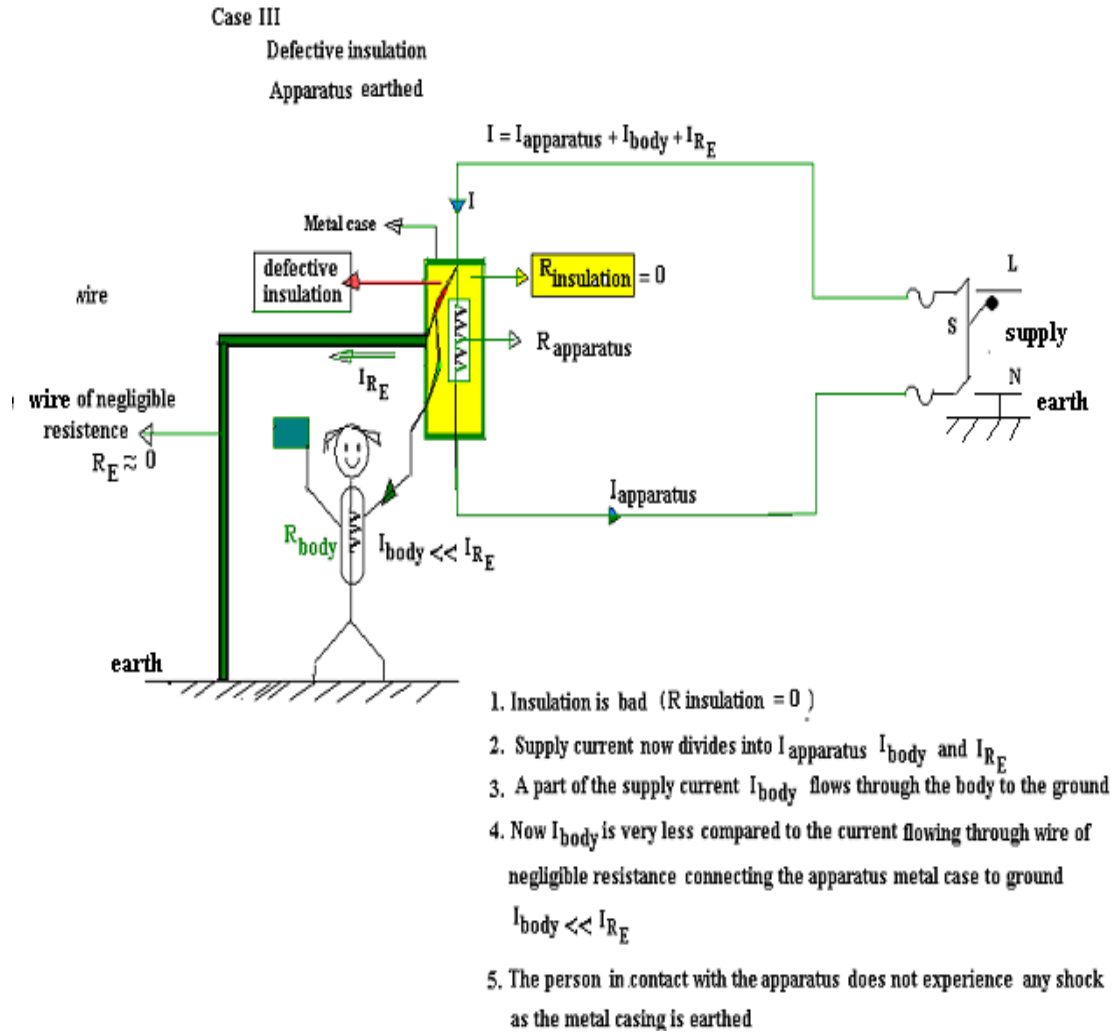

❖ **Necessity of Earthing:**

1. To protect the operating personnel from danger of shock in case they come in contact with the charged frame due to defective insulation.
2. To maintain the line voltage constant under unbalanced load condition.
3. Protection of the equipments
4. Protection of large buildings and all machines fed from overhead lines against lightning.

### ❖ Methods of Earthing:

The important methods of earthing are the plate earthing and the pipe earthing. The earth resistance for copper wire is 1 ohm and that of G I wire less than 3 ohms. The earth resistance should be kept as low as possible so that the neutral of any electrical system, which is earthed, is maintained almost at the earth potential. The typical value of the earth resistance at powerhouse is 0.5 ohm and that at substation is 1 ohm.

#### 1. Plate earthing 2. Pipe earthing

##### Plate Earthing

In this method a copper plate of 60cm x 60cm x 3.18cm or a GI plate of the size 60cm x 60cm x 6.35cm is used for earthing. The plate is placed vertically down inside the ground at a depth of 3m and is embedded in alternate layers of coal and salt for a thickness of 15 cm. In addition, water is poured for keeping the earth electrode resistance value well below a maximum of 5 ohms. The earth wire is securely bolted to the earth plate. A cement masonry chamber is built with a cast iron cover for easy regular maintenance.

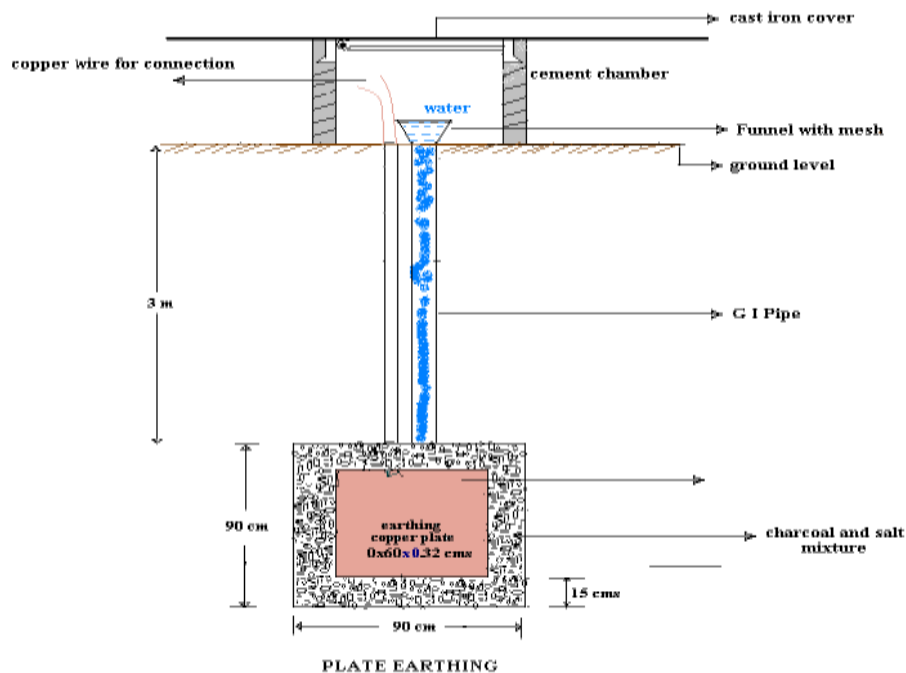

##### Pipe Earthing

Earth electrode made of a GI (galvanized) iron pipe of 38mm in diameter and length of 2m (depending on the current) with 12mm holes on the surface is placed upright at a depth of 4.75m

in a permanently wet ground. To keep the value of the earth resistance at the desired level, the area (15 cms) surrounding the GI pipe is filled with a mixture of salt and coal.. The efficiency of the earthing system is improved by pouring water through the funnel periodically. The GI earth wires of sufficient cross- sectional area are run through a 12.7mm diameter pipe (at 60cms below) from the 19mm diameter pipe and secured tightly at the top as shown in the following figure.

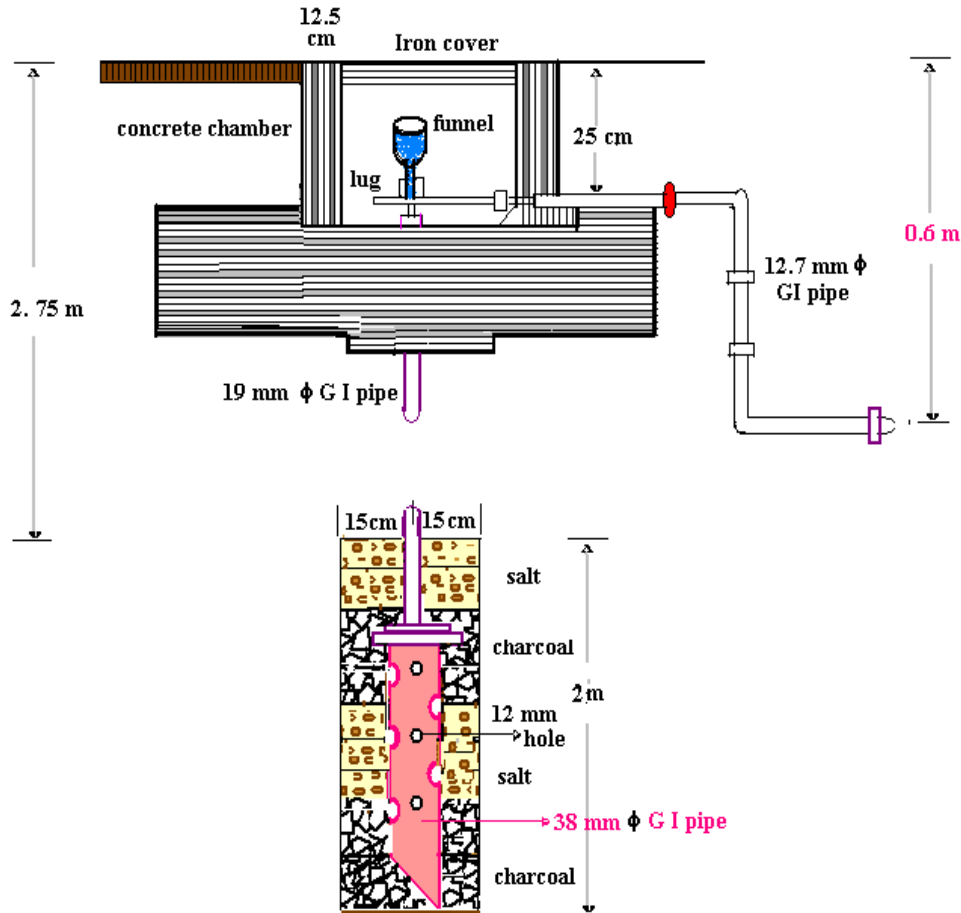

PIPE EARTHING

When compared to the plate earth system the pipe earth system can carry larger leakage currents as a much larger surface area is in contact with the soil for a given electrode size. The system also enables easy maintenance as the earth wire connection is housed at the ground level.

**PROTECTIVE DEVICES**

Protection for electrical installation must be provided in the event of faults such as short circuit, overload and earth faults. The protective circuit or device must be fast acting and isolate the faulty part of the circuit immediately. It also helps in isolating only required part of the circuit without affecting the remaining circuit during maintenance. The following devices are usually used to provide the necessary protection:

- Fuses
- Relays
- Miniature circuit breakers (MCB)
- Earth leakage circuit breakers (ELCB)

**FUSE**

The electrical equipment's are designed to carry a particular rated value of current under normal circumstances. Under abnormal conditions such as short circuit, overload or any fault the current raises above this value, damaging the equipment and sometimes resulting in fire hazard. Fuses are pressed into operation under such situations. Fuse is a safety device used in any electrical installation, which forms the weakest link between the supply and the load. It is a short length of wire made of lead / tin /alloy of lead and tin/ zinc having a low melting point and low ohmic losses. Under normal operating conditions it is designed to carry the full load current. If the current increases beyond this designed value due any of the reasons mentioned above, the fuse melts (said to be blown) isolating the power supply from the load as shown in the following figures.

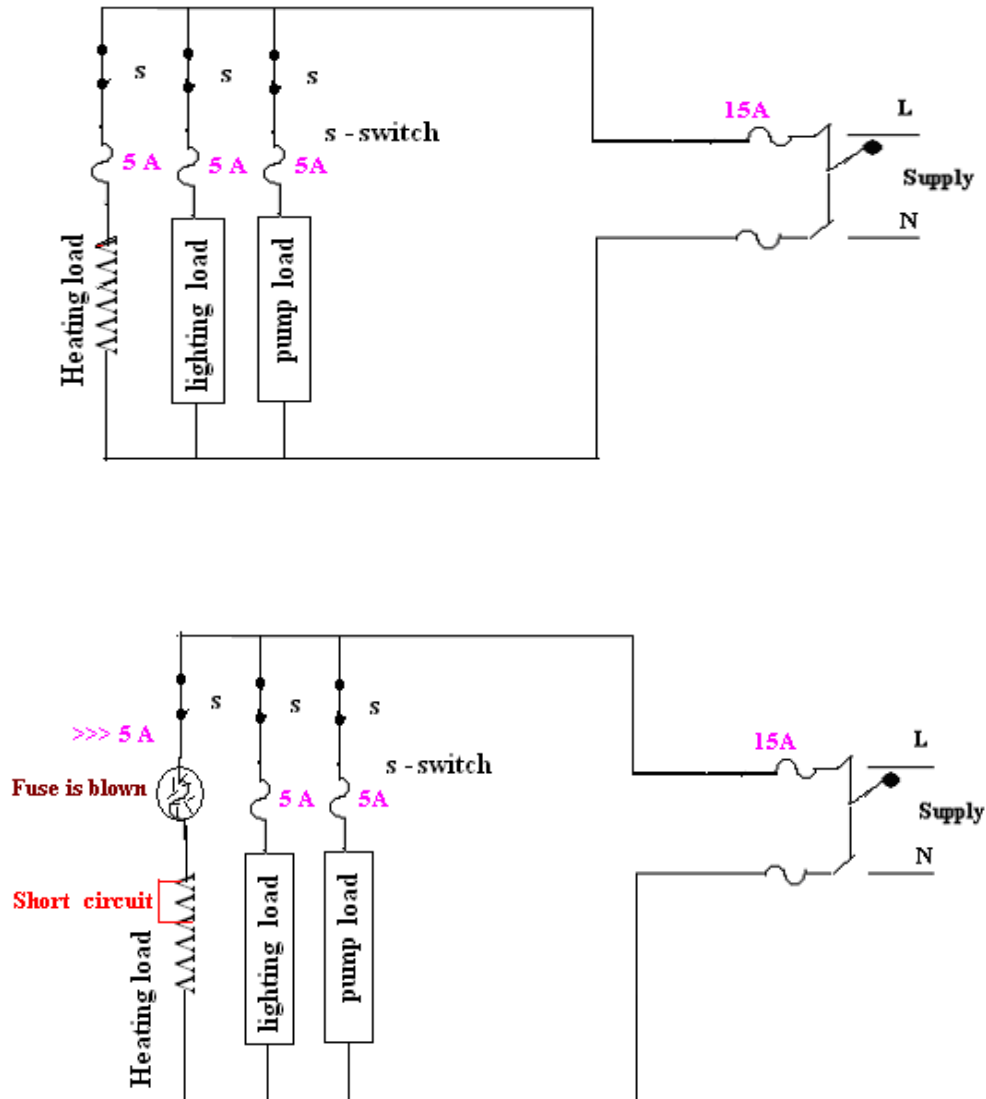

### CHARACTERISTICS OF FUSE MATERIAL

The material used for fuse wires must have the following characteristics

1. Low melting point
2. Low ohmic losses
3. High conductivity
4. Lower rate of deterioration

**Different types of fuses:**

- **Re-wirable or kit -kat fuses:** These fuses are simple in construction, cheap and available up-to a current rating of 200A. They are erratic in operation and their performance deteriorates with time.
- **Plug fuse:** The fuse carrier is provided with a glass window for visual inspection of the fuse wire.
- **Cartridge fuse:** Fuse wire usually an alloy of lead is enclosed in a strong fiber casing. The fuse element is fastened to copper caps at the ends of the casing. They are available up-to a voltage rating of 25kV. They are used for protection in lighting installations and power lines.
- **Miniature Cartridge fuses:** These are the miniature version of the higher rating cartridge fuses, which are extensively used in automobiles, TV sets, and other electronic equipment's.
- **Transformer fuse blocks:** These porcelain housed fuses are placed on secondary of the distribution transformers for protection against short circuits and overloads.
- **Expulsion fuses:** These consist of fuse wire placed in hollow tube of fiber lined with asbestos. These are suited only for out door use for example, protection of high voltage circuits.
- **Semi-enclosed re-wirable fuses:** These have limited use because of low breaking capacity.
- **Time-delay fuse:** These are specially designed to withstand a current overload for a limited time and find application in motor circuits.

**HRC CARTRIDGE FUSE:**

The high rupturing capacity or (HRC) fuse consists of a heat resistant ceramic body. Then silver or bimetallic fuse element is welded to the end brass caps. The space surrounding the fuse element is filled with quartz powder. This filler material absorbs the arc energy and extinguishes it. When the current exceeds the rated value the element melts and vaporizes. The vaporized silver fuses with the quartz and offers a high resistance and the arc is extinguished.

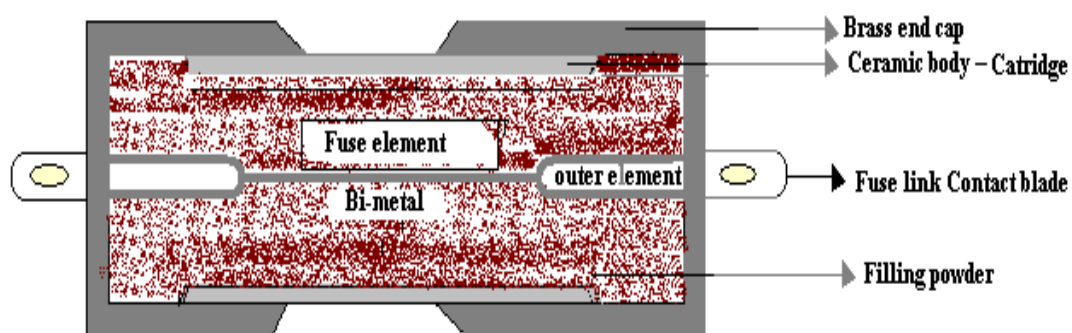

H R C Cartridge fuse

**Advantages:**

1. Fast acting
2. Highly reliable
3. Relatively cheaper in comparison to other high current interrupting device

**Disadvantages:**

1. Requires replacement
2. The associated high temperature rise will affect the performance of other devices

**TERMS RELATED WITH FUSES:**

**Rated current:** It is the maximum current, which a fuse can carry without undue heating or melting. It depends on the following factors:

1. Permissible temperature rise of the contacts of the fuse holder and the fuse material

2. Degree of deterioration due to oxidation.

**Fusing current:** The minimum current at which the fuse melts is known as the fusing current. It depends on the material characteristics, length, diameter, cross-sectional area of the fuse element and the type of enclosure used.

**Fusing Factor:** It is the ratio of the minimum fusing current to the rated current. It is always greater than unity.



## MODULE – 4

### 4a. Three Phase Circuits:

#### **Advantages of three phase system:**

In the three phase system, the alternator armature has three windings and it produces three independent alternating voltages. The magnitude and frequency of all of them is equal but they have a phase difference of  $120^\circ$  between each other. Such a three phase system has following advantages over single phase system:

- 1) The output of three phase machine is always greater than single phase machine of same size, approximately 1.5 times. So for a given size and voltage a three phase alternator occupies less space and has less cost too than single phase having same rating.
- 2) For a transmission and distribution, three phase system needs less copper or less conducting material than single phase system for given volt amperes and voltage rating so transmission becomes very much economical.
- 3) It is possible to produce rotating magnetic field with stationary coils by using three phase system. Hence three phase motors are self-starting.
- 4) In single phase system, the instantaneous power is a function of time and hence fluctuates w.r.t. time. This fluctuating power causes considerable vibrations in single phase motors. Hence performance of single phase motors is poor. While instantaneous power in symmetrical three phase system is constant.
- 5) Three phase system give steady output.
- 6) Single phase supply can be obtained from three phase but three phase cannot be obtained from single phase.
- 7) Power factor of single phase motors is poor than three phase motors of same rating.
- 8) For converting machines like rectifiers, the d.c. output voltage becomes smoother if number of phases are increased.

But it is found that optimum number of phases required to get all above said advantages is three. Any further increase in number of phases cause a lot of complications. Hence three phase system is accepted as standard polyphase system throughout the world.

**Generation of 3-phase E.M.F.**

In the 3-phase system, there are three equal voltages of the same frequency but displaced from one another by  $120^\circ$  electrical. These voltages are produced by a three-phase generator which has three identical windings or phases displaced  $120^\circ$  electrical apart. When these windings are rotated in a magnetic field, e.m.f. is induced in each winding or phase. These e.m.f. s are of the same magnitude and frequency but are displaced from one another by  $120^\circ$  electrical.

Consider three electrical coils  $a_1a_2, b_1b_2$  and  $c_1c_2$  mounted on the same axis but displaced from each other by  $120^\circ$  electrical. Let the three coils be rotated in an anticlockwise direction in a bipolar magnetic field with an angular velocity of  $\omega$  radians/sec, as shown in Fig. 3.80. Here,  $a_1, b_1$  and  $c_1$  are the start terminals and  $a_2, b_2$  and  $c_2$  are the end terminals of the coils.

When the coil  $a_1a_2$  is in the position AB shown in Fig. 3.80, the magnitude and direction of the e.m.f. s induced in the various coils is as under:

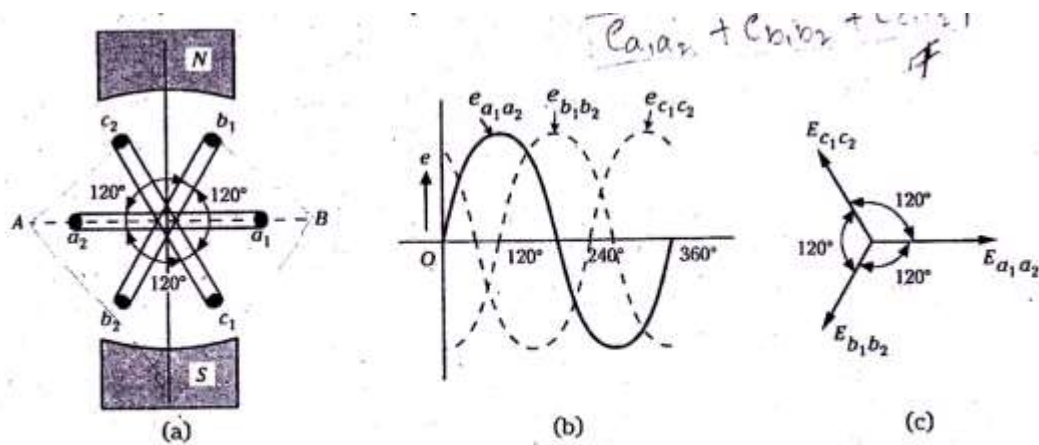

**Fig. 3.80**

- a) E.m.f. induced in coil  $a_1a_2$  is zero and is increasing in the positive direction. This is indicated by  $e_{a_1a_2}$  wave in Fig. 3.80 (b).
- b) The coil  $b_1b_2$  is  $120^\circ$  electrically behind coil  $a_1a_2$ . The e.m.f. induced in this coil is negative and is approaching maximum negative value. This is shown by the  $e_{b_1b_2}$  wave.
- c) The coil  $c_1c_2$  is  $240^\circ$  electrically behind  $a_1a_2$  or  $120^\circ$  electrically behind coil  $b_1b_2$ . The e.m.f. induced in this coil is positive and is decreasing. This is indicated by wave  $e_{c_1c_2}$ .
- Thus, it is apparent that the e.m.f.'s induced in the three coils are of the same magnitude and frequency but displaced  $120^\circ$  electrical from each other.

**Vector Diagram:** The r.m.s. values of the three phase voltage are shown vectorially in Fig. 3.80(c).

**Equations:** The equations for the three voltages are:

$$e_{a_1a_2} = E_m \sin \omega t$$

$$e_{b_1b_2} = E_m \sin_{\left[ \omega t - 120^\circ \right]} \quad ; \quad e_{c_1c_2} = E_m \sin_{\left[ \omega t - 240^\circ \right]}$$

### Meaning of phase sequence

The order in which the voltages in the phases reach their maximum positive values is called the phase sequence. For example, in Fig. 3.80(a), the three coils  $a_1a_2$ ,  $b_1b_2$  and  $c_1c_2$  are rotating in anticlockwise direction in the magnetic field. The coil  $a_1a_2$  is  $120^\circ$  electrical ahead of coil  $b_1b_2$  and  $240^\circ$  electrical ahead of coil  $c_1c_2$ . Therefore, e.m.f. in coil  $a_1a_2$  leads the e.m.f. in coil  $b_1b_2$  by  $120^\circ$  and that in coil  $c_1c_2$  by  $240^\circ$ . It is evident from Fig. 3.80(b) that  $e_{a_1a_2}$  attains maximum positive first, then  $e_{b_1b_2}$  and  $e_{c_1c_2}$ . In other words, the order in which the e.m.f. s in the three phases  $a_1a_2$ ,  $b_1b_2$  and  $c_1c_2$  attain their maximum positive values is a,b,c. Hence, the phase sequence is a,b,c.

### Naming the phases

The 3 phases may be numbered (1,2,3) or lettered (a,b,c) or specified colours (R Y B). By normal convention, sequence RYB is considered positive and R B Y negative.

### Meaning of phase sequence

It is necessary to employ some systematic notation for the solution of a.c. circuits and systems containing a number of e.m.f. s. acting and currents flowing so that the process of solution is simplified and less prone to errors.

It is normally preferred to employ double-subscript notation while dealing with a.c. electrical circuits. In this system, the order in which the subscripts are written indicates the direction in which e.m.f. acts or current flows.

For example, if e.m.f. is expressed as  $E_{ab}$ , it indicates that e.m.f. acts from a to b; if it is expressed as  $E_{ba}$ , then the e.m.f. acts in a direction opposite to that in which  $E_{ab}$  acts. (Fig. 3.81) i.e.,  $E_{ba} = -E_{ab}$ .

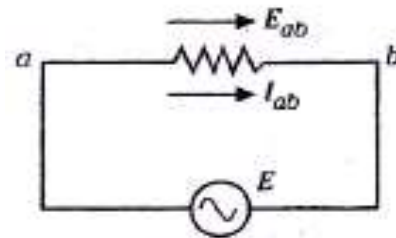

Fig. 3.81

Similarly,  $I_{ab}$  indicates that current flows in the direction from a to b but  $I_{ba}$  indicates that current flows in the direction from b to a; i.e.,  $I_{ba} = -I_{ab}$ .

### Balanced Supply and Load

When a balanced generating supply, where the three phase voltages are equal, and the phase difference is  $120^\circ$  between one another, supplies balanced equipment load, where the impedance of the three phases or three circuit loads are equal, then the current flowing through these three phases will also be equal in magnitude, and will also have a phase difference of  $120^\circ$  with one another. Such an arrangement is called a balanced load.

### Obtaining Relationship between Line & Phase Values & Expression for power for Balanced Star Connection

This system is obtained by joining together similar ends, either the start or the finish; the other ends are joined to the line wires, as shown in Fig.3.82 (a). The common point N at which similar (start or finish) ends are connected is called the neutral or star point. Normally, only three wires are carried to the external circuit, giving a 3-phase, 3-wire, star-connected system; however,

sometimes a fourth wire known as neutral wire, is carried to the neutral point of the external load circuit, giving a 3-phase, 4-wire connected system.

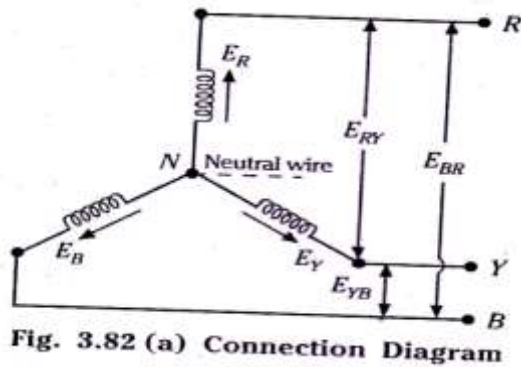

Fig. 3.82 (a) Connection Diagram

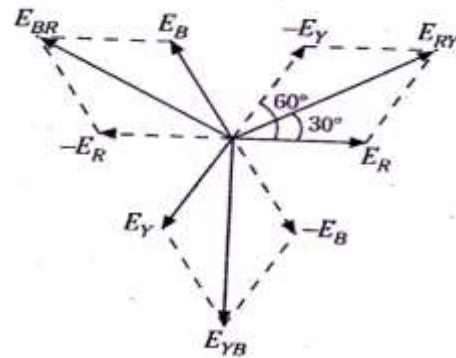

Fig. 3.82 (b) Vector Diagram of Line and Phase voltages. 3-Phase Star-Connected System

The voltage between any line and the neutral point, i.e., voltage across the phase winding, is called the phase voltage; while the voltage between any two outers is called line voltage. Usually, the neutral point is connected to earth. In Fig.3.82 (a), positive directions of e.m.f.s. are taken star point outwards. The arrow heads on e.m.f.s. and currents indicate the positive direction. Here, the 3-phases are numbered as usual: R,Y and B indicate the three natural colours red, yellow and blue respectively. By convention, sequence RYB is taken as positive and RYB as negative.

In Fig.3.82 (b), the e.m.f.s induced in the three phases, are shown vectorially. In a star-connection there are two windings between each pair of outers and due to joining of similar ends together, the e.m.f.s induced in them are in opposition.

Hence the potential difference between the two outers, know as line voltage, is the vector difference of phase e.m.f.s of the two phases concerned.

For example, the potential difference between outers R and Y or

Line voltage  $E_{RY}$ , is the vector difference of phase e.m.f.s  $E_R$  and  $E_Y$  or vector sum of phase e.m.f.s  $E_R$  and  $(-E_Y)$ .

$$\text{i.e. } E_{RY} = E_R - E_Y \quad (\text{vector difference})$$

$$\text{or } E_{RY} = E_R + (-E_Y) \quad (\text{vector sum})$$

as phase angle between vectors  $E_R$  and  $(-E_Y)$  is  $60^\circ$ ,

$\therefore$  from vector diagram shown in Fig.3.82(b),

$$E_{RY} = \sqrt{E_R^2 + E_Y^2 + 2E_R E_Y \cos 60^\circ}$$

$$\text{Let } E_R = E_Y = E_B = E_P \quad (\text{phase voltage})$$

$$\text{Then line voltage } E_{RY} = \sqrt{E_P^2 + E_P^2 + (2E_P E_P \times 0.5)} = \sqrt{3} E_P$$

Similarly, potential difference between outers Y and B or line. Voltage  $E_{YB} = E_Y - E_B = \sqrt{3} E_P$  and potential difference between outers B and R, or line voltage  $E_{BR} = E_B - E_R = \sqrt{3} E_P$ .

In a balanced star system,  $E_{RY}$ ,  $E_{YB}$  and  $E_{BR}$  are equal in magnitude and are called line voltages.

$$\therefore E_L = \sqrt{3} E_P$$

Since, in a star-connected system, each line conductor is connected to a separate phase, so the current flowing through the lines and phases are the same.

$$\text{i.e. Line current } I_L = \text{phase current } I_P$$

If the phase current has a phase difference of  $\phi$  with the voltage,

$$\text{Power output per phase} = E_P I_P \cos \phi$$

$$\text{Total power output, } P = 3E_P I_P \cos \phi$$

$$= 3 \frac{E_L}{\sqrt{3}} I_P \cos \phi$$

$$= \sqrt{3} E_L I_L \cos \phi$$

$$\text{i.e. power} = \sqrt{3} \times \text{line voltage} \times \text{line current} \times \text{power factor}$$

Apparent power of 3-phase star-connected system

$$= 3 \times \text{apparent power per phase}$$

$$= 3E_P I_P = 3 \times \frac{E_L}{\sqrt{3}} \times I_L = \sqrt{3} E_L I_L$$

**Obtaining Relationship between Line and Phase Values and Expression for Power for Balanced Delta Connection**

When the starting end of one coil is connection to the finishing end of another coil, as shown in Fig.3.83 (a), delta or mesh connection is obtained. The direction of the e.m.f.s is as shown in the diagram.

From Fig.3.83 it is clear that line current is the vector difference of phase currents of the two phases concerned. For example, the line current in red outer  $I_R$  will be equal to the vector difference of phase currents  $I_{YR}$  and  $I_{RB}$ . The current vectors are shown in Fig.3.83 (b).

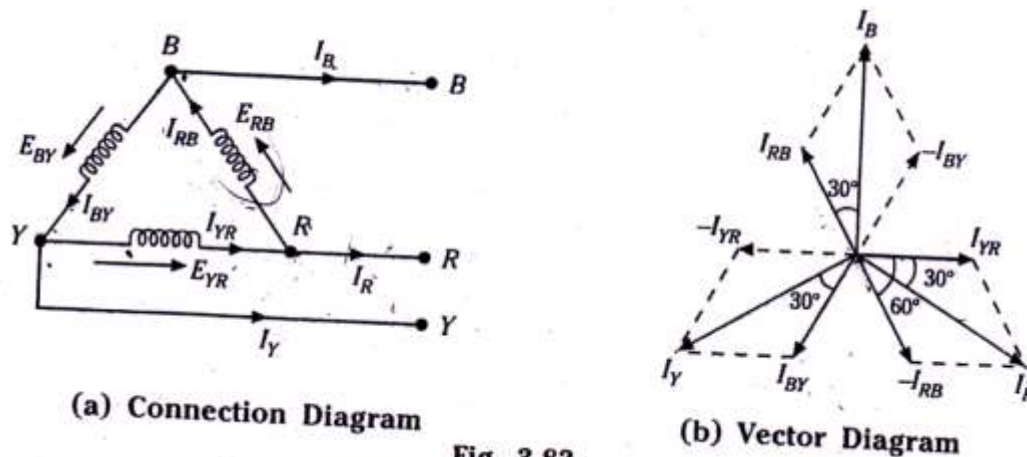

Fig. 3.83

Referring to Fig.3.83 (a) and (b),

$$\text{Line current, } I_R = I_{YR} - I_{RB} \quad (\text{vector difference})$$

$$= I_{YR} + (-I_{RB}) \quad (\text{vector sum})$$

As the phase angle between currents  $I_{YR}$  and  $-I_{RB}$  is  $60^\circ$

$$\therefore I_R = \sqrt{I_{YR}^2 + I_{RB}^2 + 2I_{YR} I_{RB} \cos 60^\circ}$$

For a balanced load, the phase current in each winding is equal and let it be =  $I_P$ .

$$\therefore \text{Line current, } I_R = \sqrt{I_{YR}^2 + I_{RB}^2 + 2I_P I_P \times 0.5} = \sqrt{3} I_P$$

Similarly, line current,  $I_Y = I_{BY} - I_{YR} = \sqrt{3} I_P$

And line current,  $I_B = I_{RB} - I_{BY} = \sqrt{3} I_P$

In a delta network, there is only one phase between any pair of line outers, so the potential difference between the outers, called the line voltage, is equal to phase voltage.

i.e. Line voltage,  $E_L = \text{phase voltage, } E_P$

Power output per phase =  $E_P I_P \cos \phi$ ,; where  $\cos \phi$  is the power factor of the load.

Total power output,  $P = 3E_P I_P \cos \phi$

$$= 3E_L \frac{I_L}{\sqrt{3}} \cos \phi$$

$$= \sqrt{3} E_L I_L \cos \phi$$

i.e. Total power output =  $\sqrt{3}$  x Line voltage x Line current x p.f.

Apparent power of 3-phase delta-connected system

$$= 3 \times \text{apparent power per phase}$$

$$= 3 E_P I_P = 3E_L \frac{I_L}{\sqrt{3}} = \sqrt{3} E_L I_L$$

**Show that in a three phase, balanced circuit, two wattmeters are sufficient to measure the total three phase power and power factor of the circuit.**

**Two wattmeter method:** The current coils of the two wattmeters are connected in any two lines while the voltage coil of each wattmeters is connected between its own current coil terminal and line without current coil. Consider star connected balanced load and two wattmeters connected as shown in fig. 13. Let us consider the rms values of the currents and voltages to prove that sum of two wattmeter gives total power consumed by three phase load.





We have, 
$$\Phi = \tan^{-1} \left[ \frac{\sqrt{3}(W_1 - W_2)}{W_1 + W_2} \right] \quad \text{here } \Phi = \Phi_{\text{new}}$$

As the total power in 3ph circuit remains same  $W_1 + W_2 = 410$  ----- (i)

$$30^\circ = \tan^{-1} \left[ \frac{\sqrt{3}(W_1 - W_2)}{40} \right]$$

$$\therefore \frac{(\tan 30^\circ)40}{\sqrt{3}} = W_1 - W_2$$

$$W_1 - W_2 = 13.33$$

(i) + (ii) gives,

$$\therefore 2W_1 = 53.33$$

$$W_1 = 26.66 \text{ kW}$$

From (i),  $W_2 = 40 - W_1 = 40 - 26.66 = 13.33$

$$\therefore W_2 = 13.33 \text{ kW}$$

**2) Three similar coils each having resistance of 10 ohm and reactance of 8 ohm are connected in star across a 400 V, 3 phase supply. Determine the i) Line current; ii) Total power and iii) Reading of each of two wattmeters connected to measure the power.**

**Ans.:**  $R=10 \Omega$ ,  $X_L=8 \Omega$ ,  $V_L=400 \text{ V}$ , star

$$\therefore Z_{\text{ph}} = 10 + j 8 \Omega = 12.082 \angle 38.659^\circ \Omega$$

$$V_{\text{ph}} = \frac{V_L}{\sqrt{3}} = \frac{400}{\sqrt{3}} = 230.94 \text{ V}, \quad \dots \text{star}$$

$$\text{i) } I_{\text{ph}} = \frac{V_{\text{ph}}}{Z_{\text{ph}}} = \frac{230.94}{12.8062} = 18.0334 \text{ V},$$

$$\therefore I_L = I_{\text{ph}} = 18.0334 \text{ A.}$$

$$\begin{aligned} \text{ii) } P_T &= \sqrt{3} V_L I_L \cos \Phi && \text{where } \Phi = 38.659^\circ \\ &= \sqrt{3} \times 400 \times 18.0334 \times \cos 38.659^\circ \\ &= 9756.2116 \text{ W} \end{aligned}$$

$$\begin{aligned} \text{iii) } W_1 &= V_L I_L \cos (30^\circ - \Phi) = 400 \times 18.0334 \times \cos (30^\circ - 38.659^\circ) \\ &= \mathbf{7131.1412 \text{ W}} \end{aligned}$$

$$\begin{aligned} W_2 &= V_L I_L \cos (30^\circ + \Phi) = 400 \times 18.0334 \times \cos (30^\circ + 38.659^\circ) \\ &= \mathbf{2625.0704 \text{ W}} \end{aligned}$$

#### **4b. Three Phase Synchronous Generators:**

Electric power is generated using three phase alternators.

**Principle:** Whenever a coil is rotated in a magnetic field an EMF will be induced in the coil. This is called the dynamically induced EMF.

Alternators are also called as Synchronous Generators due to the reason that under normal conditions the generator is to be rotated at a definite speed called “SYNCHRONOUS SPEED”,  $N_s$  R.P.M. in order to have a fixed frequency in the output EMF wave.

$N_s$  is related with the frequency as  $N_s = 120f / P$ , where  $f$  is the frequency and  $P$  is the total number of poles.

The following table gives the idea of the various synchronous speeds for various numbers of poles for the fixed frequency of 50 Hz.

<b>P</b>	<b>2</b>	<b>4</b>	<b>6</b>	<b>8</b>	<b>10</b>	<b>12</b>	<b>16</b>	.....
<b><math>N_s</math> rpm</b>	<b>3000</b>	<b>1500</b>	<b>1000</b>	<b>750</b>	<b>600</b>	<b>500</b>	<b>375</b>	.....

**Working principle of alternator :**

The alternators work on the principle of electromagnetic induction. When there is a relative motion between the conductors and the flux, e.m.f. gets induced in the conductors. The d.c. generators also work on the same principle. The only difference in practical alternator and a d.c. generator is that in an alternator the conductors are stationary and field is rotating. But for understanding purpose we can always consider relative motion of conductors with respect to the flux produced with respect to the flux produced by the field winding.

Consider a relative motion of a single conductor under the magnetic field produced by two stationary poles. The magnetic axis of the two poles produced by field is vertical, shown dotted in the fig. 34.

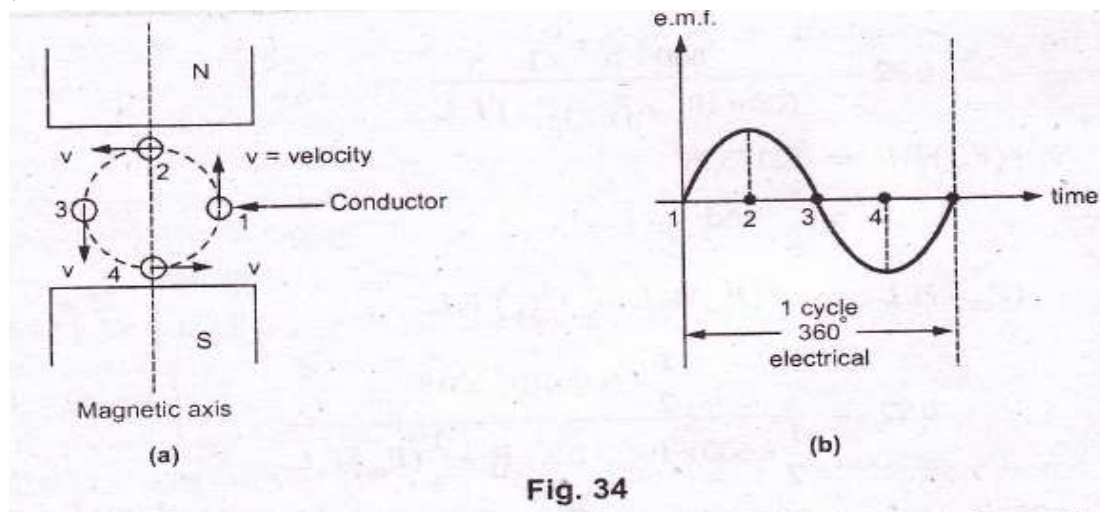

Fig. 34

Let the conductor starts rotating from position 1. At this instant, the entire velocity component is parallel to the flux lines. Hence there is no cutting of flux lines by the conductor. So  $\frac{d\phi}{dt}$  at this instant is zero and hence induced e.m.f. in the conductor is also zero.

As the conductor moves from position 1 to position 2, the part of the velocity component becomes perpendicular to the flux lines and proportional to that e.m.f. increases as the conductor moves from position 1 towards 2.

At position 2, the entire velocity component is perpendicular to the flux lines. Hence there exists maximum cutting of the flux lines. And at this instant, the induced e.m.f. in the conductor is at its maximum.

As the position of the conductor changes from 2 towards 3, the velocity component perpendicular to the flux starts decreasing and hence induced e.m.f. magnitude also starts decreasing. At position 3, again the entire velocity component is parallel to the flux lines and hence at this instant induced e.m.f. in the conductor is zero.

As the conductor moves from position 3 towards 4, the velocity component perpendicular to the flux lines again starts increasing. But the direction of velocity component now is opposite to the direction of velocity component existing during the movement of the conductor from position 1 to 2. Hence induced e.m.f. in the conductor increases but in the opposite direction.

At the position 4, it achieves maxima in the opposite direction, as the entire velocity component becomes perpendicular to the flux lines.

Again from position 4 to 1, induced e.m.f. decreases and finally at position 1, again becomes zero. This cycle continues as conductor rotates at a certain speed.

So if we plot the magnitudes of the induced e.m.f. against the time, we get alternating nature of the induced e.m.f. as shown in the fig. 34 (b). This is the working principle of an alternator.

### **TYPES AND THEIR CONSTRUCTION:**

Their two basic parts in an alternator:

- (i) Stator,
- (ii) Rotor.

Stator is the stationary part and Rotor is the revolving part.

There are two possibilities that (i) The armature can be the stator and the field system can be the rotor, and (ii) The armature can be the rotor and the field system be the stator. In practice large alternators are of the first type where in the stator is the armature and the rotor is the field system. And this type is called the “REVOLVING FIELD TYPE”.

Revolving field types are preferred due to the following reasons:

- (i) More conductors can be easily accommodated and with these high voltage and higher power capacity can be achieved.
- (ii) Armature conductors can be easily braced over a rigid frame.
- (iii) It is easier to insulate a stationary system.

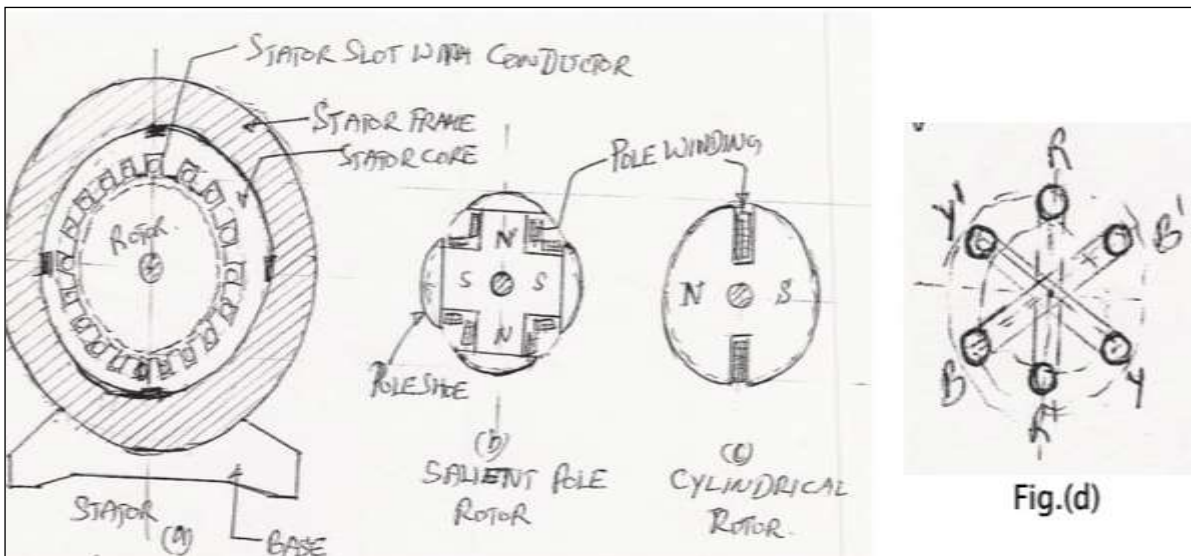

- (iv) Cooling of the conductors will be very effective with proper cooling ducts / vents in the stationary part.
- (iv) Power can be tapped easily without any risk from the stationary part through terminal bushings.
- (v) The armature conductors are totally free from any centrifugal force action which tends to drag the conductors out of the slots.

**CONSTRUCTION:**

Revolving field type alternators are further classified into two types:

- (i) Salient pole type,

(ii) (ii) Non-salient pole type or cylindrical rotor type.

Figs. (a), (b) and (c) shows the constructional features of the Alternator. Fig. (a) Represents the stator, the core of which is made of steel laminations with slots cut in its inner periphery and all the stator stampings are pressed together and are fixed to the stator frame. Three phase windings are accommodated in these slots. These coils are identical to each other and are physically distributed such that they are displaced from each other by 120 degrees as shown in fig. (d). Fig. (b) Represents the structure of a salient pole rotor where the poles are of projected type and are mounted on a spider and the field or the pole windings are wound over the pole core as shown. This type is preferred where the running speeds are low. Fig.(c) represents the structure of a non-salient pole rotor where the overall structure is like a cylinder having 2 or 4 poles. This type is preferred where the running speeds are very high. The armature windings in the stator are made of copper and are normally arranged in two layers and are wound for lap or wave depending on the requirements and are usually connected in star with the neutral terminal brought out.

### EMF Equation:

Let P be the total number of poles,  $N_s$  be the synchronous speed,  $f$  be the frequency of the induced EMF and the flux  $\Phi$  considered to be sinusoidally distributed.

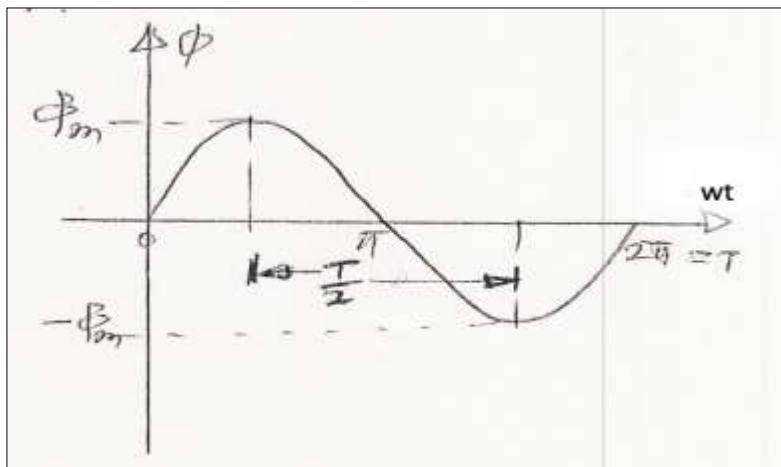

As we know that the induced emf is due to the rate of change of flux cut by coils, the average induced emf in  $T_{ph}$  number of turns is

$$E_{avg} = T_{ph} \frac{d\Phi}{dt} \text{ volts.}$$

For a flux change from  $\Phi_m$  to  $-\Phi_m$  is  $d\Phi = 2\Phi_m$  in time  $dt = T/2$  seconds,

The average induced Emf =  $T_{ph} \cdot 2\Phi_m / (T/2) = 4 T_{ph} \cdot f \cdot \Phi_m$  volts.

For a sine wave we know that the form factor is of value 1.11 =  $E_{rms} / E_{avg}$ .

Therefore,  $E_{rms} = 1.11 \cdot E_{avg}$ .

$$E_{rms} = 4.44 f \Phi_m T_{ph} \text{ volts per phase.} \dots\dots\dots(1)$$

If the armature windings are connected in star the line emf is  $E_l = 3 E_{phase}$ .

If the armature windings are connected in delta the line emf is the phase emf itself.

Equation (1) represents the theoretical value of the induced emf in each phase but in practice the Induced emf will be slightly less than the theoretical value due to the following reasons:

- (i) The armature windings are distributed throughout the armature in various slots and this is accounted by a factor called the "Distribution factor"  $K_d$  and is given by

$$K_d = \frac{\sin(m\alpha/2)}{m\sin(\alpha/2)}, \text{ where } m \text{ is the number of slots per pole per phase}$$

and  $\alpha$  is the slot angle.

$$\alpha = 180^\circ / \text{no. of slots per pole.}$$

- (ii) The span of the armature coil is less than a full pitch – This is done deliberately to eliminate some unwanted harmonics in the emf wave, this fact is accounted by a factor called the coil span factor or the pitch factor,  $K_p$  and is given by

$$K_p = \cos(\beta/2), \text{ where } \beta \text{ is the angle by which the coils are short chorded.}$$

The modified Emf equation with these two factors taken into account will be

$$E = 4.44 K_d \cdot K_p \cdot f \cdot T_{ph} \text{ volts per phase.}$$

The product of  $K_d$  and  $K_p$  is called as the winding factor  $K_w$  .which is of value around 0.95.

**VOLTAGE REGULATION:**

The voltage regulation of an alternator is defined as the change in the terminal voltage between no load and full load at a specified power factor, without any change in the speed and excitation.

$$(No\ load\ terminal\ voltage - Full\ load\ terminal\ voltage)$$

$$\% \text{ Voltage regulation} = \frac{\text{-----}}{\text{Full load terminal voltage}} \times 100$$

$$E - V$$

$$\% \text{ Voltage regulation} = \frac{\text{-----}}{V} \times 100$$

The idea of voltage regulation is necessary to judge the performance of an alternator. Lesser the value of the regulation better will be the load sharing capacity at better efficiency.

**1. A 3 phase, 6 pole, star connected alternator has 48 slots and 12 conductors per slot on the armature. If the rotor at 1200RPM and the flux per pole is 0.3 Wb, calculate the e.m.f. induced in the armature. The coils are full pitched and the winding factor is 0.95.**

sol. :  $P = 6$ , slots = 48, conductors/ slots = 12,  $\Phi = 0.3$  wb

$$N_s = \frac{120 \times f}{P}; \quad N_s = 1200 \text{ rpm}$$

$$f = \frac{PN_s}{120} = \frac{6 \times 1200}{120} = 60 \text{ Hz}$$

for full pitched winding,  $K_c = 1$ ,  $K_d = 0.95$

$$\text{Total conductors} = \text{slots} \times \text{conductors/slot} = 48 \times 12 = 576$$

$$Z_{ph} = \frac{Z}{3} = \frac{576}{3} = 192$$

$$T_{ph} = \frac{Z_{ph}}{2} = \frac{192}{2} = 96$$

$$E_{ph} = 4.44 K_c K_d f \Phi T_{ph}$$

$$E_{ph} = 4.44 \times 1 \times 0.95 \times 60 \times 0.3 \times 96$$



$$= 75.9 \times 96$$

$$E_{ph} = 7288.70 \text{ volts}$$

$$E_{line} = \sqrt{3} E_{ph} = \sqrt{3} \times 7288.70$$

$$E_{line} = 12.624 \text{ Kv}$$

### Difference between salient and cylindrical type of rotor :

	<b>Salient pole type</b>	<b>Smooth cylindrical type</b>
1	Poles are projecting out from the surface.	Portion of the cylinder acts as poles hence poles are non-projecting.
2	Air gap is non uniform.	Air gap is uniform due to smooth cylindrical periphery.
3	Diameter is high and axial length is small.	Small diameter and large axial length is the feature.
4	Mechanically weak.	Mechanically robust.
5	Preferred for low speed alternators.	Preferred for high speed alternators i.e. for turboalternators.
6	Prime mover used is water turbines, I.C. engines.	Prime mover used are steam turbines, electric motors.
7	For same size, the rating is smaller than cylindrical type.	For same size, rating is higher than salient pole type.
8	Separate damper winding is provided	Separate damper winding is not necessary.

Explain voltage regulation of an alternator and its significance.

### Voltage regulation of an alternator:

Under the load condition, the terminal voltages of alternator is less than the induced e.m.f.  $E_{ph}$ . So if the load is disconnected,  $V_{ph}$  will change from  $V_{ph}$  to  $E_{ph}$ , if flux and speed is maintained constant. This is because when load is disconnected  $I_a$  is zero hence there are no voltage drops and no armature flux to cause armature reaction. This change in the terminal voltage is significant in defining the voltage regulation.

The voltage regulation of an alternator is defined as the change in its terminal voltage when full load is removed, keeping field excitation and speed constant, divided by the rated terminal voltage.

So if,  $V_{ph}$  = Rated terminal voltage

$E_{ph}$  = No load induced e.m.f.

Then voltage regulation is defined as,

$$\% \text{ Reg} = \frac{E_{ph} - V_{ph}}{V_{ph}} \times 100$$

The value of the regulation not only depends on the load current but also on the power factor of the load. For lagging and unity p.f. conditions there is always drop in the terminal voltage hence regulation values are always positive. While for leading capacitive load conditions, the terminal voltage increases as load current increases. Hence regulation is negative in such cases. The relationship between load current and the terminal voltage is called load characteristics for various load power factor conditions are shown in the fig. 38.

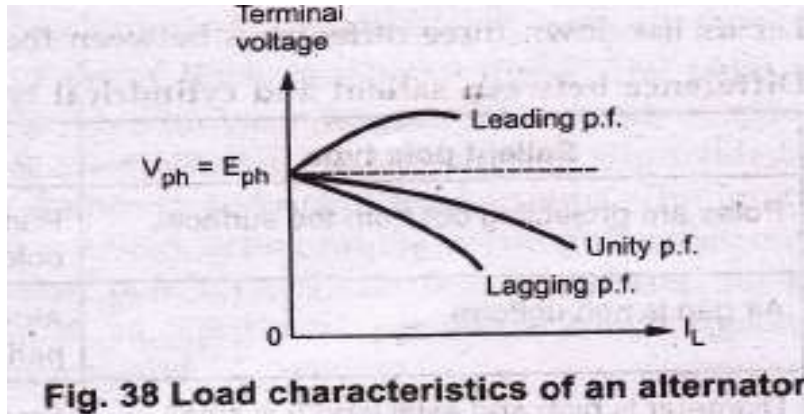

**3) A 3 phase, 6 pole, star connected alternator has 48 slots and 12 conductors per slot on the armature. If the rotor at 1200RPM and the flux per pole is 0.3 Wb, calculate the e.m.f. induced in the armature. The coils are full pitched and the winding factor is 0.95.**

**sol. :** P = 6, slots = 48, conductors/ slots = 12,  $\Phi = 0.3$  wb

$$N_s = \frac{120 \times f}{P}; \quad N_s = 1200 \text{ rpm}$$

$$f = \frac{PN_s}{120} = \frac{6 \times 1200}{120} = 60 \text{ Hz}$$

for full pitched winding,  $K_c = 1$ ,  $K_d = 0.95$

Total conductors = slots  $\times$  conductors/slot =  $48 \times 12 = 576$

$$Z_{ph} = \frac{Z}{3} = \frac{576}{3} = 192$$

$$T_{ph} = \frac{Z_{ph}}{2} = \frac{192}{2} = 96$$

$$E_{ph} = 4.44 K_c K_d f \Phi T_{ph}$$

$$E_{ph} = 4.44 \times 1 \times 0.95 \times 60 \times 0.3 \times 96$$

$$= 75.9 \times 96$$

$$E_{ph} = 7288.70 \text{ volts}$$

$$E_{line} = \sqrt{3} E_{ph} = \sqrt{3} \times 7288.70$$

$$E_{line} = 12.624 \text{ Kv}$$

## MODULE – 5

### 5a. Single Phase Transformers:

**TRANSFORMER** is a static device which transfer electric energy from one electric circuit to another at any desired voltage without any change in frequency.

**PRINCIPLE:-** A transformer works on the principle of mutual induction. “Whenever a change in current takes place in a coil there will be an induced emf in the other coil wound over the same magnetic core”. This is the principle of mutual induction by which the two coils are said to be coupled with each other.

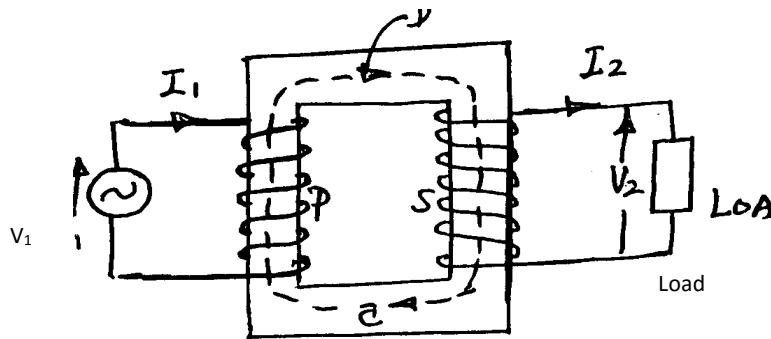

Fig.1

The fig1 shows the general arrangement of a transformer. C is the iron core made of laminated sheets of about 0.35mm thick insulated from one another by varnish or thin paper. The purpose of laminating the core is to reduce the power loss due to eddy currents induced by the alternating magnetic flux. The vertical portions of the core are called limbs and the top and bottom portions are called the yokes. Coils P and S are wound on the limbs. Coil P is connected to the supply and therefore called as the primary, coil S is connected to the load and is called as the secondary.

An alternating voltage applied to P drives an alternating current through P and this current produces an alternating flux in the iron core, the mean path of the flux is represented by the dotted line D. This flux links with the coil S and thereby induces an emf in S.

### TYPES AND CONSTRUCTION OF TRANSFORMERS

There are two basic circuits in a transformer

**1) Magnetic circuit****2) Electric circuit**

The core forms the magnetic circuit and the electric circuit consists of two windings primary and secondary and is made of pure copper. There are two types of single phase transformers.

**a) CORE TYPE****b) SHELL TYPE**

Figs (a) and (b) shows the details of the elevation and plan of a core type transformer. The limbs are wound with half the L.V. and half the H.V. windings with proper insulation between them. The whole assembly taken inside a steel tank filled with oil for the purpose of insulation and cooling.

**CORE TYPE TRANSFORMER.**

In the core type the core is surrounded by the coils but in the shell type the core is on the either side of the coils. There are three limbs and the central limb is of large cross section than that of outer limbs, and both the LV and HV windings are wound on the central limb and the outer limb is only for providing the return path for the flux.

The windings are of concentric type (i.e. LV on which the HV windings) or Sandwich type.

The core is made of very thin laminations of high grade silicon steel material to reduce the eddy current loss and Hysteresis losses in the core.

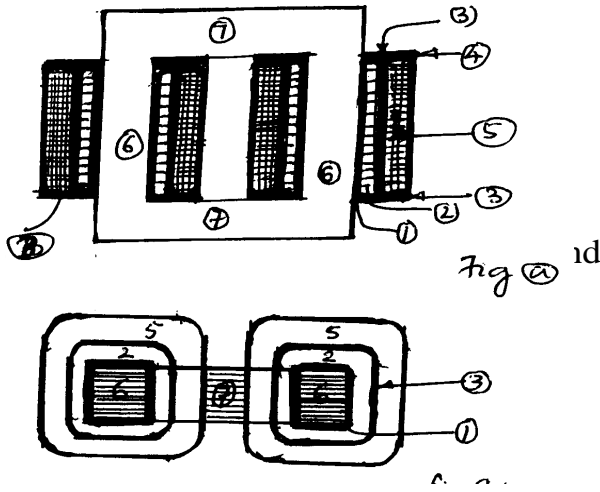
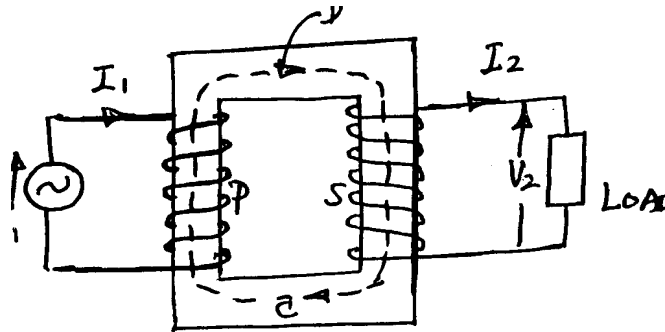

- 1- Insulation between L V and the core.
- 2- L V winding.
- 3- Insulation between L V winding.

- 4- Insulation between the yoke.
- 5- H V winding.
- 6- Limbs.
- 7- Yoke.

FIG. (b)



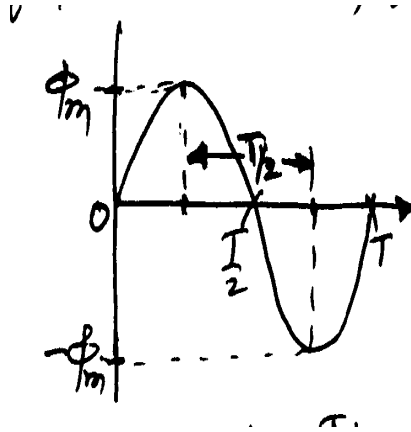

Figure showing the sinusoidally varying flux of peak value  $\Phi_m$ .

Whenever a coil of  $N$  no- of turns are linked by a time varying flux  $\phi$ , the average emf induced in this coil is

$$e = \frac{Nd\phi}{dt}$$

As the flux is sinusoidal the change in flux from  $+\phi_m$  to  $-\phi_m$  is  $d\phi = 2\phi_m$ , and this change takes place in a duration  $dt = T/2$  seconds.

The average induced emf in these  $N$  number of turns is

$$E_{avg} = N \cdot d\phi / dt = N \cdot 2\phi_m / (T/2) = 4\phi_m N / T = 4f\phi_m N \text{ volts (as } f = 1/T)$$

We know that the Form factor of a pure sine wave **F.F.** =  $E_{rms}/E_{avg} = 1.11$

Therefore,  **$E_{rms} = 1.11 E_{avg}$** .

$$= (1.11) (4f\phi_m N) = 4.44 f\phi_m N \text{ volts.}$$

In the primary coil,  $N = N_1$ ,  **$E_1 = 4.44f\phi_m N_1$  volts**

In the secondary coil,  $N = N_2$ ,  **$E_2 = 4.44f\phi_m N_2$  volts**

### **TRANSFORMATION RATIO:**

It is defined as the ratio of the secondary induced emf to the primary induced emf.

Therefore,  $E_1 / E_2 = N_1 / N_2 = K$

For an ideal (loss free) transformer, the input power is equal to the output power.

Therefore  $E_1 I_1 = E_2 I_2$ , from which,  $E_2 / E_1 = I_1 / I_2$

Also the induced emf per turn is same for both the primary and secondary turns.

If the value of the transformation ratio  $K > 1$ , then it is a **step up** case.

If the value of the transformation ratio  $K < 1$ , then it is a **step down** case.

If the value of the transformation ratio  $K = 1$ , then it is a **one:one** transformer.

### **LOSSES AND EFFICIENCY:**

There are two types of power losses occur in a transformer

1) **Iron loss**

2) **Copper loss**

1) **Iron Loss:** This is the power loss that occurs in the iron part. This loss is due to the alternating frequency of the emf. Iron loss is further classified into two other losses.

a) **Eddy current loss**                      b) **Hysteresis loss**

a) **EDDY CURRENT LOSS:** This power loss is due to the alternating flux linking the core, which will induce an emf in the core called the eddy emf, due to which a current called the eddy current is being circulated in the core. As there is some resistance in the core with this eddy current circulation converts into heat called the eddy current power loss. Eddy current loss is proportional to the square of the supply frequency.

b) **HYSTERESIS LOSS:** This is the loss in the iron core, due to the magnetic reversal of the flux in the core, which results in the form of heat in the core. This loss is directly proportional to the supply frequency.



Eddy current loss can be minimized by using the core made of thin sheets of silicon steel material, and each lamination is coated with varnish insulation to suppress the path of the eddy currents.

Hysteresis loss can be minimized by using the core material having high permeability.

2) **COPPER LOSS:** This is the power loss that occurs in the primary and secondary coils when the transformer is on load. This power is wasted in the form of heat due to the resistance of the coils. This loss is proportional to the square of the load hence it is called the Variable loss whereas the Iron loss is called as the Constant loss as the supply voltage and frequency are constants

**EFFICIENCY:** It is the ratio of the out put power to the input power of a transformer

$$\begin{aligned} \text{Input} &= \text{Output} + \text{Total losses} \\ &= \text{Output} + \text{Iron loss} + \text{Copper loss} \end{aligned}$$

$$\begin{aligned} \eta &= \frac{\text{output power}}{\text{output power} + \text{Iron loss} + \text{copper loss}} \\ &= \frac{V_2 I_2 \cos\phi}{V_2 I_2 \cos\phi + W_{\text{iron}} + W_{\text{copper}}} \end{aligned}$$

Where,  $V_2$  is the secondary (out put) voltage,  $I_2$  is the secondary (out put) current and  $\cos\Phi$  is the power factor of the load.

The transformers are normally specified with their ratings as KVA,

$$\begin{aligned} \text{Therefore,} & \quad (\text{KVA})(10^3) \cos\Phi \\ \text{Efficiency} &= \frac{\text{-----}}{(\text{KVA})(10^3) \cos\Phi + W_{\text{iron}} + W_{\text{copper}}} \end{aligned}$$

Since the copper loss varies as the square of the load the efficiency of the transformer at any desired load  $x$  is given by

$$x. (\text{KVA})(10^3) \cos\Phi$$

$$\text{Efficiency} = \frac{\text{Output}}{\text{Input}} = \frac{x \cdot (\text{KVA})(10^3) \cos\Phi}{x \cdot (\text{KVA})(10^3) \cos\Phi + W_{\text{iron}} + (x)^2 W_{\text{copper}}}$$

Where  $W_{\text{copper}}$  is the copper loss at full load

$$W_{\text{copper}} = I^2 R \text{ watts}$$

**CONDITION FOR MAXIMUM EFFICIENCY:**

In general for the efficiency to be maximum for any device the losses must be minimum. Between the iron and copper losses the iron loss is the fixed loss and the copper loss is the variable loss. When these two losses are equal and also minimum the efficiency will be maximum.

Therefore the condition for maximum efficiency in a transformer is

$$\text{Iron loss} = \text{Copper loss} \quad (\text{whichever is minimum})$$

**VOLTAGE REGULATION:**

The voltage regulation of a transformer is defined as the change in the secondary terminal voltage between no load and full load at a specified power factor expressed as a percentage of the full load terminal voltage.

$$\text{Voltage Regulation} = \frac{(\text{No load secondary voltage}) - (\text{Full load secondary voltage})}{(\text{Full load secondary voltage})} \times 100$$

Voltage regulation is a measure of the change in the terminal voltage of a transformer between No load and Full load. A good transformer has least value of the regulation of the order of  $\pm 5\%$

1. A 600 KVA transformer has an efficiency of 92% at full load, unity p.f. and at half load, 0.9 p.f. determine its efficiency of 75% of full load and 0.9 p.f.

Sol. : S = 600 KVA, % η = 92% on full load and half load both

$$\text{On full load, } \% \eta = \frac{(\text{VA rating})\cos\phi_2}{(\text{VA rating})\cos\phi_2 + P_i + (P_{cu})F.L.} \times 100$$

$$0.92 = \frac{600 \times 10^3 \times 1}{600 \times 10^3 \times P_i + (P_{cu})F.L.}$$

$$P_i + (P_{cu})F.L. = 52173.91 \dots\dots\dots$$

(1)

On half load,  $n = \frac{1}{2}$  and

$$(P_{cu})H.L. = n^2(P_{cu})F.L. = \frac{1}{4}(P_{cu})F.L.$$

$$0.92 = \frac{\frac{1}{2} \times 600 \times 10^3 \times 0.9}{\frac{1}{2} \times 600 \times 10^3 \times 0.9 + P_i + \frac{1}{4}(P_{cu})F.L.}$$

$$P_i + 0.25(P_{cu})F.L. = 23478.261 \dots\dots\dots (2)$$

Subtracting (2) from (1),

$$0.75(P_{cu})F.L. = 28695.64$$

$$(P_{cu})F.L. = 38260.86 \text{ watts}$$

and  $P_i = 13913.04 \text{ watts}$

Now  $n = 0.75$  i.e., 75% of full load and  $\cos\phi_2 = 0.9$

$$(P_{cu}) \text{ new} = n^2 (P_{cu}) F.L. = (0.75)^2 \times (P_{cu})F.L. .$$

$$\% \eta = \frac{n(\text{VA rating})\cos\phi_2}{n(\text{VA rating})\cos\phi_2 + P_i + (P_{cu})\text{new}} \times 100$$

$$= \frac{0.75 \times 600 \times 10^3 \times 0.9}{0.75 \times 600 \times 10^3 \times 0.9 + 13913.04 + (0.75)^2 \times 38260.86} \times 100$$

$$= 91.95\%$$

Transformer has 80 turns on the secondary.

Calculate:

- i) The rated primary and secondary currents
- ii) The number of primary turns
- iii) The maximum value of flux
- iv) Voltage induced per turn.

**Sol:** KVA rating = 250

$$V_1 = 11000 \text{ volts}$$

$$V_2 = 415 \text{ volts}$$

$$N_2 = 80$$

$$\frac{N_2}{N_1} = \frac{V_2}{V_1}$$

$$N_1 = \left( \frac{N_2}{\frac{V_2}{V_1}} \right) = N_2 \left( \frac{V_1}{V_2} \right) = 80 \left( \frac{11000}{415} \right) = 2120$$

$$N_1 = 2120$$

$$\text{KVA} = V_1 I_1 = V_2 I_2$$

$$I_1 = \frac{\text{KVA}}{V_1} = \frac{250 \times 10^3}{11000} = 22.72 \text{ A}$$

$$I_2 = \frac{\text{KVA}}{V_2} = \frac{250 \times 10^3}{415} = 602.40 \text{ A}$$

Neglecting drops in primary,

$$V_1 = E_1 = 11000$$

$$E_1 = 4.44 f \phi_m \times N_1$$

$$\therefore \frac{11000}{4.44 \times 50 \times 2120} = \phi_m$$

$$\therefore \phi_m = 0.023 \text{ Wb} = 23 \text{ mWb}$$

$$\text{Voltage induced per turn} = \frac{E_1}{N_1} = \frac{11000}{2120} = 5.1886 \text{ volts.}$$

3. In a 25 kVA, 2000/200 V Transformer, the iron and copper losses are 350 watts and 400 watts respectively, calculate the efficiency at U.P.F. at half and 3/4<sup>th</sup> full load.

$$\text{Sol.:} \quad S = 25 \text{ kVA}$$

$$P_i = 350 \text{ W}, \quad (P_{cu})_{FL} = 400 \text{ W}$$

i) At half load,  $\cos \phi = 1$

$$\frac{(P_{cu})_{H.L.}}{(P_{cu})_{F.L.}} = \left[ \frac{I_{HL}}{I_{FL}} \right]^2 = \left[ \frac{\frac{1}{2} I_{FL}}{I_{FL}} \right]^2 = \frac{1}{4}$$

$$(P_{cu})_{HL} = \frac{1}{4} \times 400 = 100 \text{ W}$$

$$\% \text{ Efficiency} = \frac{\text{kVA rating} \times \cos \phi}{\text{kVA rating} \times \cos \phi + P_i + P_{cu}} \times 100$$

$$= \frac{\frac{1}{2} \times 25 \times 1 \times 10^3}{\frac{1}{2} \times 25 \times 1 \times 10^3 + 350 + 100} \times 100$$

$$= \frac{12.5 \times 10^3}{12.5 \times 10^3 + 450} \times 100$$

$$\therefore \% \text{ Efficiency} = 96.525$$

ii) At  $\frac{3}{4}$  th load,  $\cos\phi = 1$

$$\frac{(P_{cu})_{\frac{3}{4} \text{ load}}}{(P_{cu})_{F.L.}} = \left(\frac{I_{\frac{3}{4}}}{I_{FL}}\right)^2$$

$$(P_{cu})_{\frac{3}{4} \text{ load}} = \left(\frac{3}{4}\right)^2 \times P_{cu FL} = \frac{9}{16} \times 400 = 225 \text{ W}$$

$$\% \text{ Efficiency} = \frac{\text{kVA rating} \times \cos\phi}{\text{kVA rating} \times \cos\phi + P_i + P_{cu}} \times 100$$

$$= \frac{\frac{3}{4} \times 25 \times 10^3 \times 1}{\frac{3}{4} \times 25 \times 10^3 + 350 + 225} \times 100$$

$\therefore$  % Efficiency = 97.02%

4. A 600 KVA transformer has an efficiency of 92% at full load, unity p.f. and at half load, 0.9 p.f. determine its efficiency of 75% of full load and 0.9 p.f.

**Sol. :**  $S = 600 \text{ KVA}$ , %  $\eta = 92\%$  on full load and half load both

$$\text{On full load, } \% \eta = \frac{(\text{VA rating})\cos\phi_2}{(\text{VA rating})\cos\phi_2 + P_i + (P_{cu})_{F.L.}} \times 100$$

$$0.92 = \frac{600 \times 10^3 \times 1}{600 \times 10^3 \times P_i + (P_{cu})_{F.L.}}$$

$$P_i + (P_{cu})_{F.L.} = 52173.91 \quad \dots\dots\dots$$

(1)

On half load,  $n = \frac{1}{2}$  and

$$(P_{cu})_{H.L.} = n^2(P_{cu})_{F.L.} = \frac{1}{4}(P_{cu})_{F.L.}$$

$$0.92 = \frac{\frac{1}{2} \times 600 \times 10^3 \times 0.9}{\frac{1}{2} \times 600 \times 10^3 \times 0.9 + P_i + \frac{1}{4}(P_{cu})_{F.L.}}$$

$$P_i + 0.25(P_{cu})F.L. = 23478.261 \quad \dots\dots\dots (2)$$

Subtracting (2) from (1),

$$0.75(P_{cu})F.L. = 28695.64$$

$$(P_{cu})F.L. = 38260.86 \text{ watts}$$

and  $P_i = 13913.04 \text{ watts}$

Now  $n = 0.75$  i.e., 75% of full load and  $\cos\Phi_2 = 0.9$

$$(P_{cu})_{new} = n^2 (P_{cu}) F.L. = (0.75)^2 \times (P_{cu})F.L. .$$

$$\begin{aligned} \% \eta &= \frac{n(\text{VA rating})\cos\Phi_2}{n(\text{VA rating})\cos\Phi_2 + P_i + (P_{cu})_{new}} \times 100 \\ &= \frac{0.75 \times 600 \times 10^3 \times 0.9}{0.75 \times 600 \times 10^3 \times 0.9 + 13913.04 + (0.75)^2 \times 38260.86} \times 100 \\ &= 91.95\% \end{aligned}$$

## 5b. Three Phase Induction Motors:

### INTRODUCTION

The asynchronous motors or the induction motors are most widely used ac motors in industry. They convert electrical energy in AC form into mechanical energy. They work on the principle of electromagnetic induction. They are simple and rugged in construction, quite economical with good operating characteristics and efficiency, requiring minimum maintenance, but have a low starting torque. They run at practically constant speed from no load to full load condition. The 3 - phase induction motors are self-starting while the single phase motors are not self-starting as they produce equal and opposite torques (zero resultant torque) making the rotor stationary. The speed of the squirrel cage induction motor cannot be varied easily.

### CLASSIFICATION -

They are basically classified into two types based on the rotor construction

1. Squirrel cage motor
2. Slip ring motor or phase wound motor

### CONSTRUCTION

Three phase induction motor consists of two parts

(1) Stator (2) rotor

### 1. Stator

It is the stationary part of the motor supporting the entire motor assembly. This outer frame is made up of a single piece of cast iron in case of small machines. In case of larger machines they are fabricated in sections of steel and bolted together. The core is made of thin laminations of silicon steel and flash enameled to reduce eddy current and hysteresis losses. Slots are evenly spaced on the inner periphery of the laminations. Conductors insulated from each other are placed in these slots and are connected to form a balanced 3 - phase star or delta connected stator circuit. Depending on the desired speed the stator winding is wound for the required number of poles. Greater the speed lesser is the number of poles.

### 2. Rotor

Squirrel cage rotors are widely used because of their ruggedness. The rotor consists of hollow laminated core with parallel slots provided on the outer periphery. The rotor conductors are solid bars of copper, aluminium or their alloys. The bars are inserted from the ends into the semi-enclosed slots and are brazed to the thick short circuited end rings. This sort of construction resembles a squirrel cage hence the name “squirrel cage induction motor”. The rotor conductors being permanently short circuited prevent the addition of any external resistance to the rotor circuit to improve the inherent low starting torque. The rotor bars are not placed parallel to each other but are slightly skewed which reduces the magnetic hum and prevents cogging of the rotor and the stator teeth.

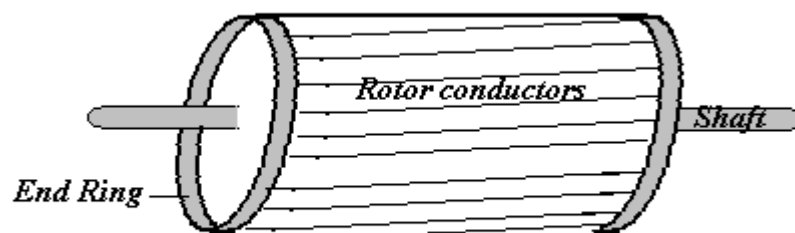

*Squirrel cage induction rotor*



The rotor in case of a phase wound/ slip ring motor has a 3-phase double layer distributed winding made up of coils, similar to that of an alternator. The rotor winding is usually star connected and is wound to the number of stator poles. The terminals are brought out and connected to three slip rings mounted on the rotor shaft with the brushes resting on the slip rings. The brushes are externally connected to the star connected rheostat in case a higher starting torque and modification in the speed torque characteristics are required. Under normal running conditions all the slip rings are automatically short circuited by a metal collar provided on the shaft and the condition is similar to that of a cage rotor. Provision is made to lift the brushes to reduce the frictional losses. The slip ring and the enclosures are made of phosphor bronze.

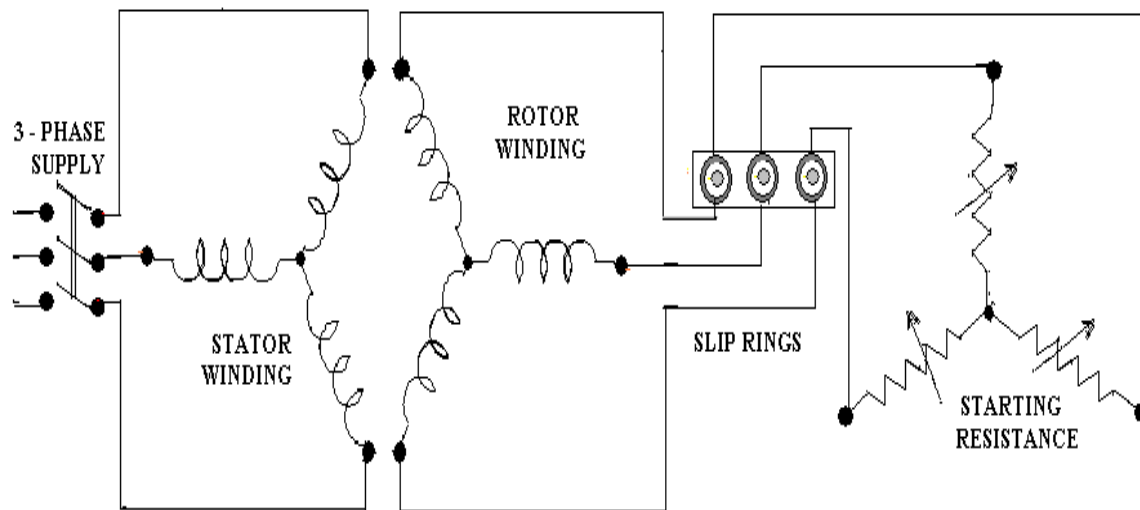

SLIP RING INDUCTION MOTOR

In both the type of motors the shaft and bearings (ball and roller) are designed for trouble free operation. Fans are provided on the shaft for effective circulation of air. The insulated (mica and varnish) stator and rotor windings are rigidly braced to withstand the short circuit forces and heavy centrifugal forces respectively. Care is taken to maintain a uniform air gap between the stator and the rotor.

### Comparison of the squirrel cage and slip ring rotors

The cage rotor has the following advantages:

1. Rugged in construction and economical.

2. Has a slightly higher efficiency and better power factor than slip ring motor.
3. The absence of slip rings and brushes eliminate the risk of sparking which helps in a totally enclosed fan cooled (TEFC) construction.

The advantages of the slip ring rotor are:

1. The starting torque is much higher and the starting current much lower when compared to a cage motor with the inclusion of external resistance.
2. The speed can be varied by means of solid state switching

## WORKING OF THE INDUCTION MOTOR

### a) Production of a rotating magnetic field

Consider a 3- phase induction motor whose stator windings mutually displaced from each other by  $120^\circ$  are connected in delta and energized by a 3- phase supply.

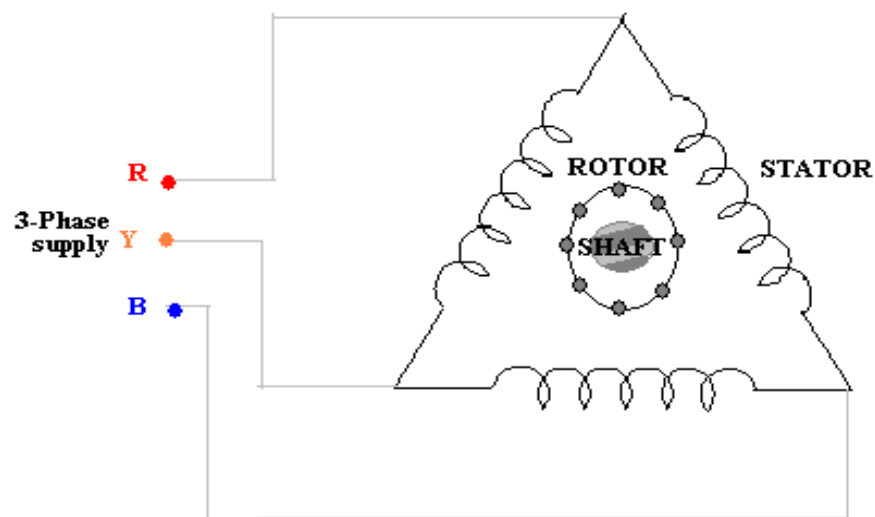

The currents flowing in each phase will set up a flux in the respective phases as

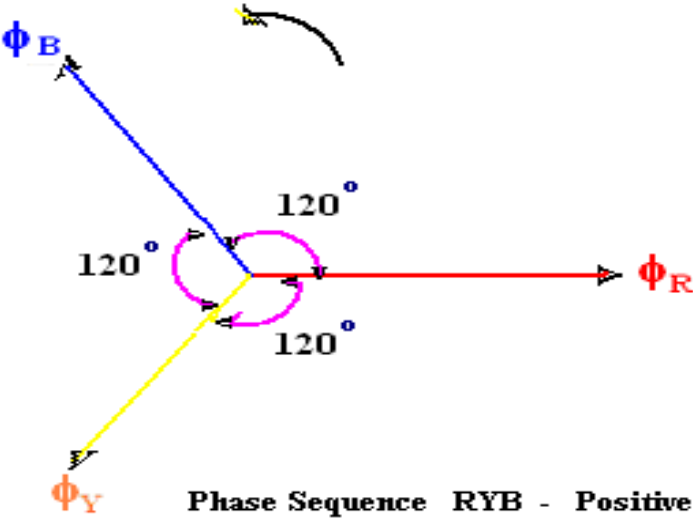
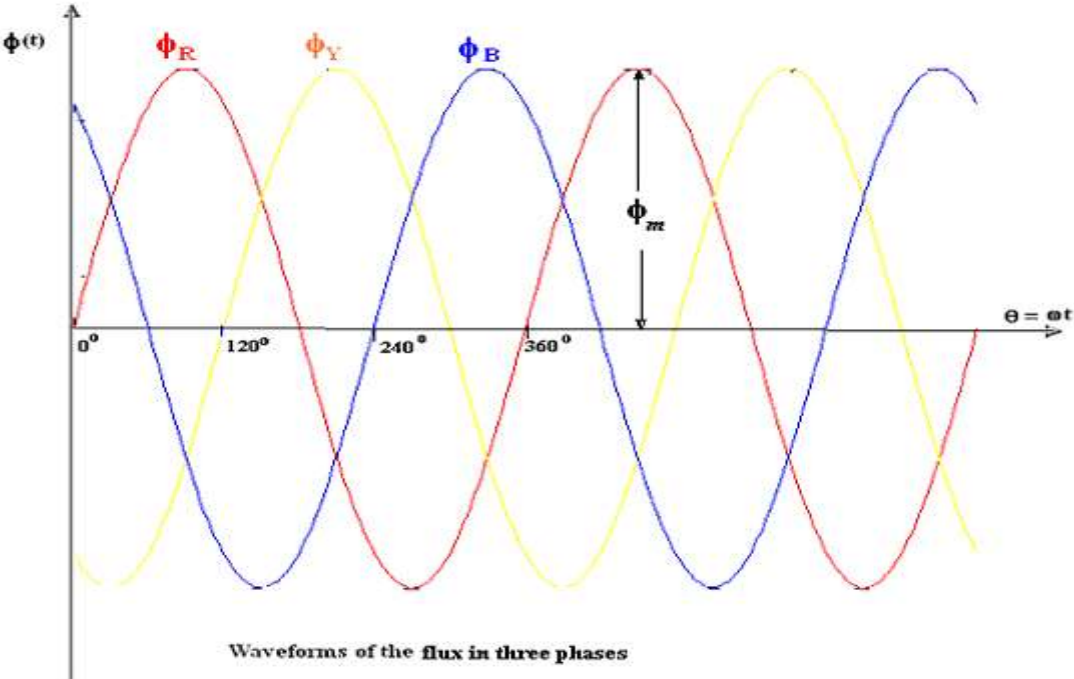

The corresponding phase fluxes can be represented by the following equations

$$\begin{aligned}\Phi_R &= \Phi_m \sin \omega t = \Phi_m \sin \theta & \Phi_B &= \Phi_m \sin(\omega t - 240^\circ) \\ \Phi_Y &= \Phi_m \sin(\omega t - 120^\circ) & \Phi_B &= \Phi_m \sin(\theta - 240^\circ) \\ \Phi_Y &= \Phi_m \sin(\theta - 120^\circ)\end{aligned}$$

The resultant flux at any instant is given by the vector sum of the flux in each of the phases.

(i) When  $\theta = 0^\circ$ , from the flux waveform diagram, we have

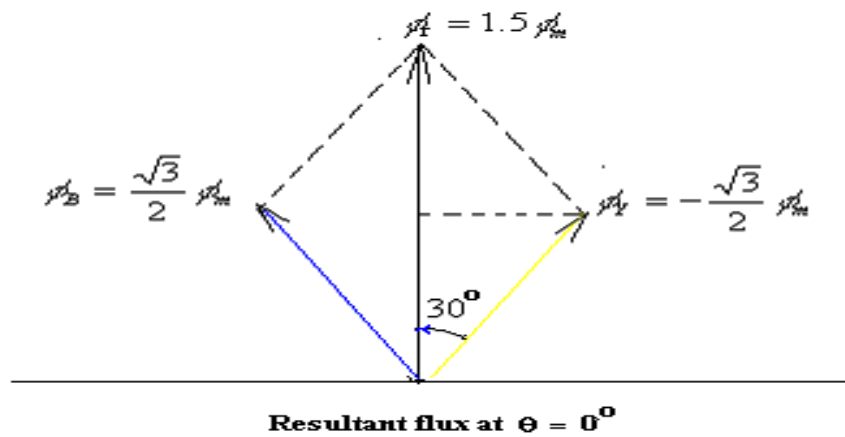

$$\phi_R = 0$$

$$\phi_Y = \phi_m \sin(-120^\circ) = -\frac{\sqrt{3}}{2} \phi_m$$

$$\phi_B = \phi_m \sin(-240^\circ) = \frac{\sqrt{3}}{2} \phi_m$$

The resultant flux  $\phi_r$  is given by,

$$\phi_r = 2 * \frac{\sqrt{3}}{2} \phi_m \cos(30^\circ) = 1.5 \phi_m$$

$$\phi_B = \frac{\sqrt{3}}{2} \phi_m$$

$$\phi_Y = -\frac{\sqrt{3}}{2} \phi_m$$

$$\phi_r = 1.5\phi_m$$

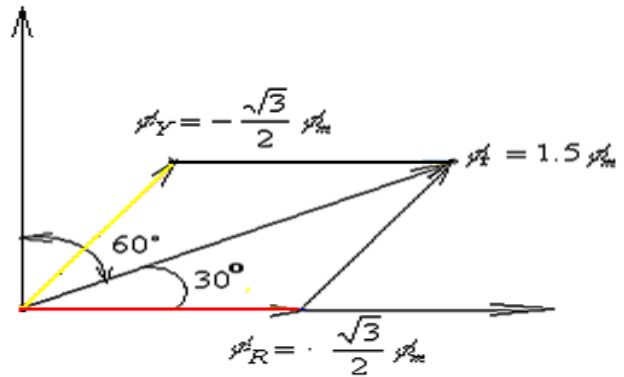

**Resultant flux at  $\theta = 60^\circ$**

(ii) When  $\theta = 60^\circ$

$$\phi_R = \frac{\sqrt{3}}{2} \phi_m$$

$$\phi_Y = -\frac{\sqrt{3}}{2} \phi_m$$

$$\phi_B = 0$$

(iii) When  $\theta = 120^\circ$

$$\phi_R = \frac{\sqrt{3}}{2} \phi_m$$

$$\phi_Y = 0$$

$$\phi_B = -\frac{\sqrt{3}}{2} \phi_m$$

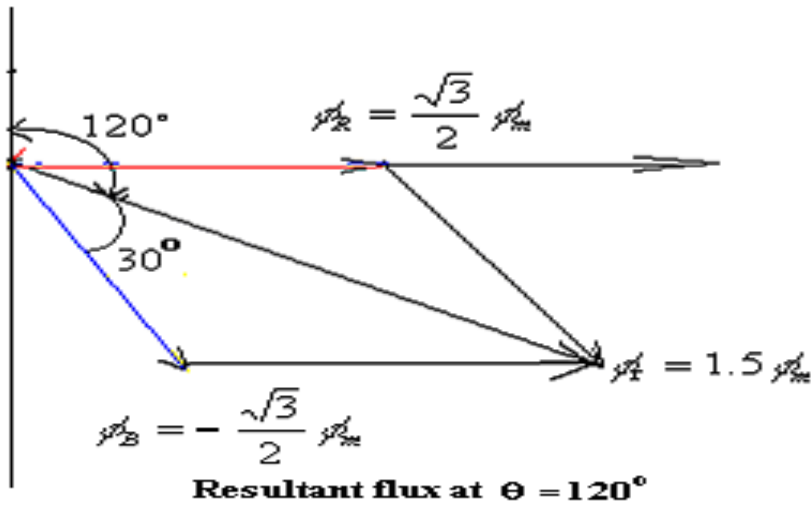

(iv) When  $\theta = 180^\circ$

$$\phi_R = 0;$$

$$\phi_Y = \frac{\sqrt{3}}{2} \phi_m$$

$$\phi_B = -\frac{\sqrt{3}}{2} \phi$$

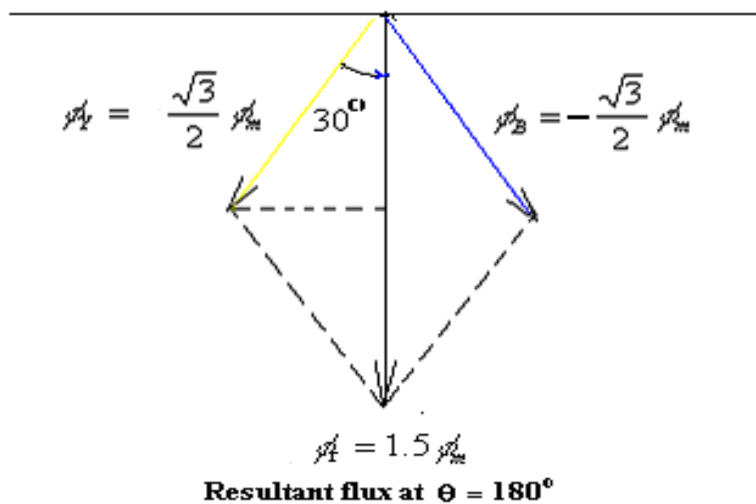

From the above discussion it is very clear that when the stator of a 3-phase induction motor is energized, a magnetic field of constant magnitude ( $1.5 \phi_m$ ) rotating at synchronous speed

( $N_s$ ) with respect to stator winding is produced.

**(b) Rotation of the rotor**

Consider a 3- phase stator winding energized from a 3 phase supply. As explained earlier a rotating magnetic field is produced running at a synchronous speed  $N_s$

$$N_s = \frac{120 f}{P}$$

Where  $f$  = supply frequency

$P$  = Number of stator poles

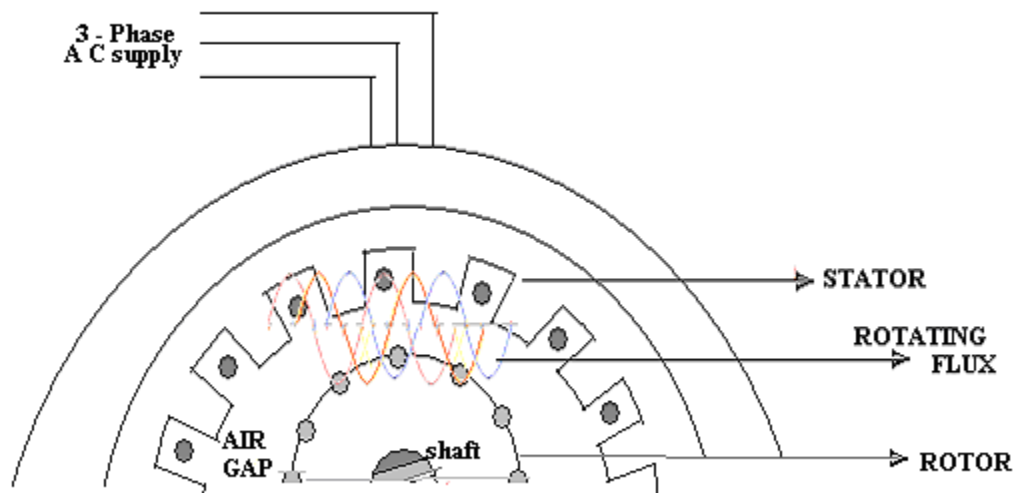

**ANIMATION INSTRUCTION**

Consider a portion of 3- phase induction motor as shown in the above figure which is representative in nature. The rotating field crosses the air gap and cuts the initially stationary rotor conductors. Due to the relative speed between the rotating magnetic field and the initially stationary rotor, (change of flux linking with the conductor) an e.m.f. is induced in the rotor conductors, in accordance with the Faraday’s laws of electromagnetic induction. Current flows in

the rotor conductors as the rotor circuit is short circuited. Now the situation is similar to that of a current carrying conductor placed in a magnetic field. Hence, the rotor conductors experience a mechanical force which eventually leads to production of torque. This torque tends to move the rotor in the same direction as that of the rotating magnetic field.

### CONCEPT OF SLIP (S)

According to Lenz's law, the direction of rotor current will be such that they tend to oppose the cause producing it. The cause producing the rotor current is the relative speed between the rotating field and the stationary rotor. Hence, to reduce this relative speed, the rotor starts running in the same direction as that of stator field and tries to catch it. In practice the rotor can never reach the speed of the rotating magnetic field produced by the stator. This is because if rotor speed equals the synchronous speed, then there is no relative speed between the rotating magnetic field and the rotor. This makes the rotor current zero and hence no torque is produced and the rotor will tend to remain stationary. In practice, windage and friction losses cause the rotor to slow down. Hence, the rotor speed (N) is always less than the stator field speed ( $N_s$ ). Thus the induction motor cannot run with **ZERO SLIP. The frequency of the rotor current**

$f_r = sf$ . The difference between the synchronous speed ( $N_s$ ) of the rotating stator field and the actual rotor speed (N) is called the **slip speed**.

Slip speed =  $N_s - N$  depends upon the load on the motor

$$\% \text{ Slip (s)} = \frac{N_s - N}{N_s} * 100$$

**Note:** In an induction motor the slip value ranges from 2% to 4%

### APPLICATIONS OF INDUCTION MOTORS

#### **Squirrel cage induction motor**

Squirrel cage induction motors are simple and rugged in construction, are relatively cheap and require little maintenance. Hence, squirrel cage induction motors are preferred in most of the industrial applications such as in



- i) Lathes
- ii) Drilling machines
- iii) Agricultural and industrial pumps
- iv) Industrial drives.

### **Slip ring induction motors**

Slip ring induction motors when compared to squirrel cage motors have high starting torque, smooth acceleration under heavy loads, adjustable speed and good running characteristics.

They are used in

- i) Lifts
- ii) Cranes
- iii) Conveyors, etc.,

### **Necessity of starters for 3 phase induction motor**

When a 3- phase motor of higher rating is switched on directly from the mains it draws a starting current of about 4 -7 times the full load (depending upon on the design) current. This will cause a drop in the voltage affecting the performance of other loads connected to the mains. Hence starters are used to limit the initial current drawn by the 3 phase induction motors.

The starting current is limited by applying reduced voltage in case of squirrel cage type induction motor and by increasing the impedance of the motor circuit in case of slip ring type induction motor. This can be achieved by the following methods.

#### **1. Star –delta starter**

#### **2. Auto transformer starter**

#### **3. Soft starter**

### **Star delta starter**

The star delta starter is used for squirrel cage induction motor whose stator winding is delta connected during normal running conditions. The two ends of each phase of the stator winding are drawn out and connected to the starter terminals as shown in the following figure.

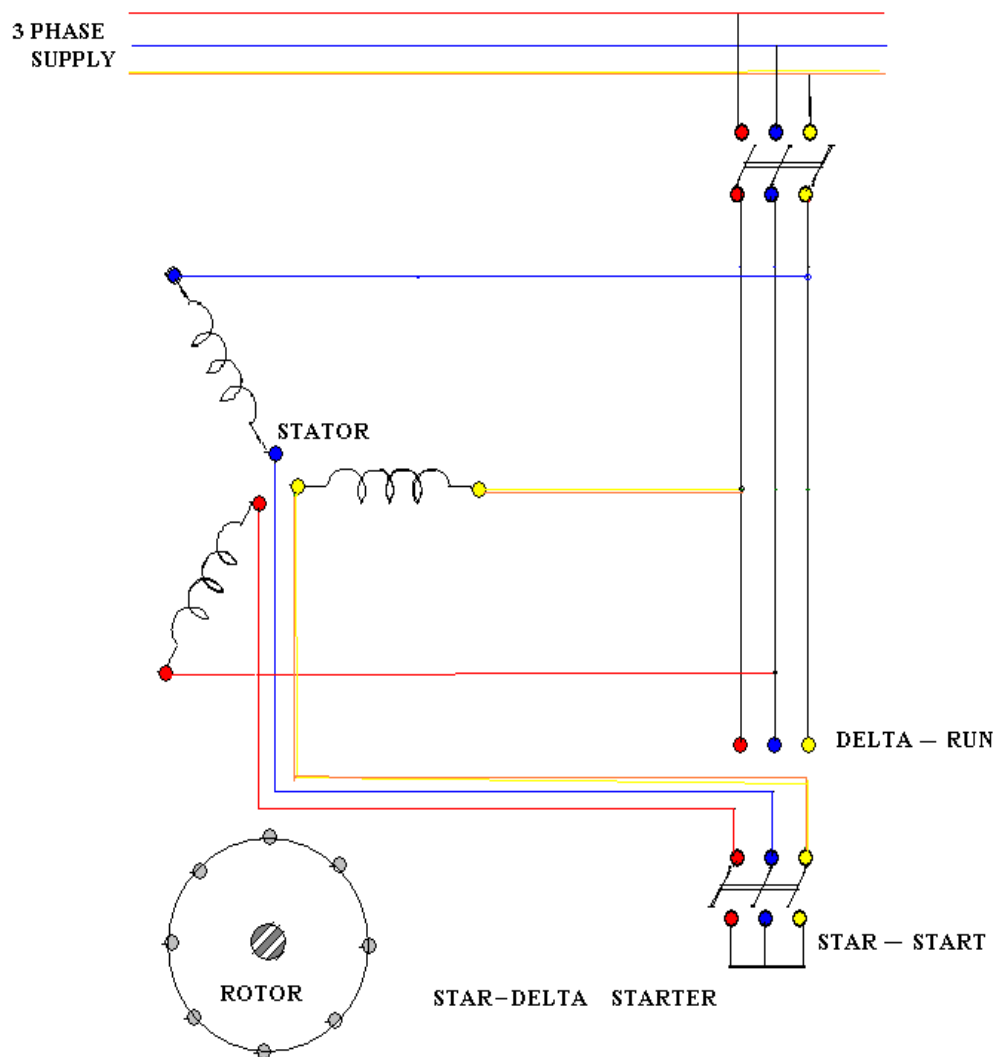

When the switch is closed on the star-start side

- (1) The winding is to be shown connected in star
- (2) The current  $I = 1/3 * (I_{\text{direct switching}})$
- (3) Reduction in voltage by  $1/\sqrt{3}$

$$V = V_{\text{supply}} * 1/\sqrt{3}$$

When the switch is closed on to delta –run side

- (1) the winding to be shown connected in delta
- (2) application of normal voltage  $V_{\text{supply}}$

(3) normal current I

During starting the starter switch is thrown on to the **STAR - START**. In this position the stator winding is connected in star fashion and the voltage per phase is  $1/\sqrt{3}$  of the supply voltage. This will limit the current at starting to  $1/3$  of the value drawn during direct switching. When the motor accelerates the starter switch is thrown on to the **DELTA - RUN** side. In this position the stator winding gets connected in the  $\Delta$  fashion and the motor draws the normal rated current.

**WORKED EXAMPLES**

1. A 12 pole, 3 phase alternator is coupled to an engine running at 500 rpm. It supplies an Induction Motor which has a full load speed of 1440 rpm. Find the percentage slip and the number of poles of the motor.

Solution:  $N_A$  = synchronous speed of the alternator

$$P N_A = 12 \times 500$$

$$F = \frac{120}{P N_A} = \frac{120}{120} = 50 \text{ Hz (from alternator data)}$$

When the supply frequency is 50 Hz, the synchronous speed can be 750 rpm, 1500 rpm, 3000rpm etc., since the actual speed is 1440 rpm and the slip is always less than 5% the synchronous speed of the Induction motor is 1500 rpm.

$$N_s - N = 1500 - 1440$$

$$s = \frac{N_s - N}{N_s} = \frac{1500 - 1440}{1500} = 0.04 \text{ OR } 4\%$$

$$N_s = \frac{120f}{P} = \frac{120 \times 50}{P}$$

$$N_s = \frac{120f}{P} = 1500$$

$$P = \frac{120f}{N_s}$$

$$\therefore P = 4$$

2. A 6 pole induction motor is supplied by a 10 pole alternator, which is driven at 600 rpm. If the induction motor is running at 970 rpm, determine its percentage slip.

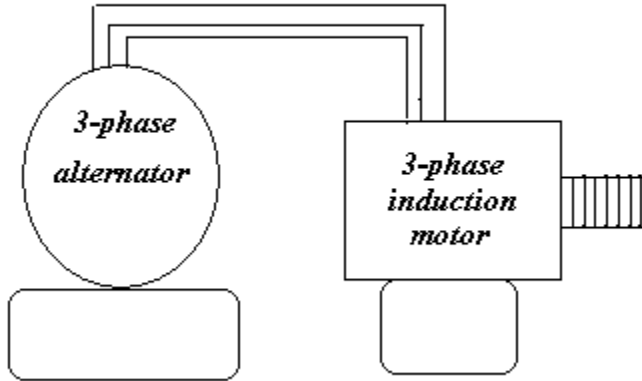

$$P N_A = 10 \times 600$$

From alternator data:  $f = \frac{P N_A}{120} = \frac{10 \times 600}{120} = 50 \text{ Hz}$

$$\frac{120}{120}$$

Synchronous speed of the induction motor

$$N_s = \frac{120f}{P} = \frac{120 \times 50}{6} = 1000 \text{ rpm}$$

From I.M. data:

$$\% \text{ slip} = \frac{N_s - N}{N_s} \times 100 = \frac{1000 - 970}{1000} = 3\%$$

3. A 12 pole, 3 phase alternator is driven by a 440V, 3 phase, 6 pole Induction Motor running at a slip of 3%. Find frequency of the EMF generated by the alternator

$$\text{For induction motor: } N_s = \frac{120f}{P} = \frac{120 \times 50}{6} = 1000 \text{ rpm}$$

$$N = (1 - s)N_s = (1 - 0.03)1000 = 970 \text{ rpm}$$

As the alternator is driven by the Induction motor, the alternator runs at 970 r.p.m.

For alternator:  $f = \frac{PN}{120} = \frac{12 \times 970}{120} = 97\text{Hz}$

4. A three phase 4 pole, 440 V, 50Hz induction motor runs with a slip of 4%. Find the rotor speed and frequency of the rotor current.

Solution:

$$N_s = \frac{120f}{P} = \frac{120 \times 50}{4} = 1500\text{rpm}$$

$$S = \frac{N_s - N}{N_s} \text{ i.e. } 0.04 = \frac{1500 - N}{1500}, \therefore N = 1440\text{rpm}$$

$$f_r = sf = 0.04 \times 50 = 2\text{Hz}$$

5. A 3 phase, 50Hz 6 pole induction motor has a full load percentage slip of 3%.

Find (i) Synchronous speed and (ii) Actual Speed

Solution:

$$N_s = \frac{120f}{P} = \frac{120 \times 50}{6} = 1000\text{rpm}$$

$$\therefore S = \frac{N_s - N}{N_s} \text{ i.e. } 0.03 = \frac{1000 - N}{1000} \therefore N = 970\text{rpm}$$

6. A 3 phase induction motor has 6 poles and runs at 960 RPM on full load. It is supplied from an alternator having 4 poles and running at 1500 RPM. Calculate the full load slip and the frequency of the rotor currents of the induction motor.

Solution:

$$f = \frac{PN}{120} = \frac{4 \times 1500}{120} = 50\text{Hz} (\text{from alternator data})$$

for Induction motor

$$N_s = \frac{120f}{P} = \frac{120 \times 50}{6} = 1000\text{rpm}$$

$$S = \frac{N_s - N}{N_s} = \frac{1000 - 960}{1000} = 0.04 \text{ or } 4\%$$

$$f_r = sf = 0.04 \times 50 = 2\text{Hz}$$