

OPERATION RESEARCH

Subject Code	:	06CS661	IA Marks	:	25
No. of Lecture Hrs./ Week	:	04	Exam Hours	:	03
Total No. of Lecture Hrs.	:	52	Exam Marks	:	100

UNIT - 1

INTRODUCTION: Linear programming, Definition, scope of Operations Research (O.R) approach and limitations of OR Models, Characteristics and phases of OR Mathematical formulation of L.P. Problems. Graphical solution methods. **6 Hours**

UNIT - 2

LINEAR PROGRAMMING PROBLEMS: The simplex method - slack, surplus and artificial variables. Concept of duality, two phase method, dual simplex method, degeneracy, and procedure for resolving degenerate cases. **7 Hours**

UNIT - 3

TRANSPORTATION PROBLEM: Formulation of transportation model, Basic feasible solution using different methods, Optimality Methods, Unbalanced transportation problem, Degeneracy in transportation problems, Applications of Transportation problems. Assignment Problem: Formulation, unbalanced assignment problem, Traveling salesman problem. **7 Hours**

UNIT - 4

SEQUENCING: Johnsons algorithm, n - jobs to 2 machines, n jobs 3machines, n jobs m machines without passing sequence. 2 jobs n machines with passing. Graphical solutions priority rules. **6 Hours**

PART - B

UNIT – 5

QUEUING THEORY: Queuing system and their characteristics. The M/M/1 Queuing system, Steady state performance analysing of M/M/ 1 and M/M/C queuing model. **6 Hours**

UNIT - 6

PERT-CPM TECHNIQUES: Network construction, determining critical path, floats, scheduling by network, project duration, variance under probabilistic models, prediction of date of completion, crashing of simple networks. **7 Hours**

UNIT - 7

GAME THEORY: Formulation of games, Two person-Zero sum game, games with and without saddle point, Graphical solution ($2 \times n$, $m \times 2$ game), dominance property. **7 Hours**

UNIT - 8

INTEGER PROGRAMMING: Gomory's technique, branch and bound algorithm for integer programming problems, zero one algorithm **6 Hours**

TEXT BOOKS:

1. **Operations Research and Introduction**, Taha H. A. – Pearson Education edition
2. **Operations Research**, S. D. Sharma –Kedarnath Ramnath & Co 2002.

REFERENCE BOOKS:

1. **“Operation Research”** AM Natarajan, P. Balasubramani, A Tamilaravari Pearson 2005
2. **Introduction to operation research**, Hiller and liberman, Mc Graw Hill. 5th edition 2001.
3. **Operations Research: Principles and practice:** Ravindran, Phillips & Solberg, Wiley India lts, 2nd Edition 2007
4. **Operations Research**, Prem Kumar Gupta, D S Hira, S Chand Pub, New Delhi, 2007

TABLE OF CONTENTS

1. INTRODUCTION, FORMULATION OF LPP	-	03 - 20
2. LINEAR PROGRAMMING PROBLEMS, SIMPLEX METHOD	-	21 – 37
3. TRANSPORTATION PROBLEM	-	38 - 57
4. QUEUING THEORY	-	58 – 74
5. PERT-CPM TECHNIQUES	-	75 - 85
6. GAME THEORY	-	86 – 93
7. INTEGER PROGRAMMING	-	94 - 98

INTRODUCTION

- Operations research, operational research, or simply OR, is the use of mathematical models, statistics and algorithms to aid in decision-making. It is most often used to analyze complex real-world systems, typically with the goal of improving or optimizing performance. It is one form of applied mathematics.
- The terms operations research and management science are often used synonymously. When a distinction is drawn, management science generally implies a closer relationship to the problems of business management.
- Operations research also closely relates to industrial engineering. Industrial engineering takes more of an engineering point of view, and industrial engineers typically consider OR techniques to be a major part of their toolset.
- Some of the primary tools used by operations researchers are statistics, optimization, stochastics, queueing theory, game theory, graph theory, and simulation. Because of the computational nature of these fields OR also has ties to computer science, and operations researchers regularly use custom-written or off-the-shelf software.
- Operations research is distinguished by its ability to look at and improve an entire system, rather than concentrating only on specific elements (though this is often done as well). An operations researcher faced with a new problem is expected to determine which techniques are most appropriate given the nature of the system, the goals for improvement, and constraints on time and computing power. For this and other reasons, the human element of OR is vital. Like any tools, OR techniques cannot solve problems by themselves.

Areas of application

A few examples of applications in which operations research is currently used include the following:

- ❖ designing the layout of a factory for efficient flow of materials
- ❖ constructing a telecommunications network at low cost while still guaranteeing quality service if particular connections become very busy or get damaged
- ❖ determining the routes of school buses so that as few buses are needed as possible
- ❖ designing the layout of a computer chip to reduce manufacturing time (therefore reducing cost)
- ❖ managing the flow of raw materials and products in a supply chain based on uncertain demand for the finished products

Unit –I

Introduction & Formulation of LPP

Define OR

OR is the application of scientific methods, techniques and tools to problems involving the operations of a system so as to provide those in control of the system with optimum solutions to the problems.

Characteristics of OR

1. its system orientation
2. the use of interdisciplinary teams
3. application of scientific method
4. uncovering of new problems
5. improvement in the quality of decisions
6. use of computer
7. quantitative solutions
8. human factors

1. **System (or executive) orientation of OR**

production dept.: Uninterrupted production runs, minimize set-up and clean-up costs.

marketing dept.: to meet special demands at short notice.

finance dept.: minimize inventories should rise and fall with rise and fall in company's sales.

personnel dept.: maintaining a constant production level during slack period.

2. **The use of interdisciplinary teams.**

Psychologist: want better worker or best products.

Mechanical Engg.: will try to improve the machine.

Software engg.: updated software to solve problems.

that is, no single person can collect all the useful scientific information from all disciplines.

3. **Application of scientific method**

Most scientific research, such as chemistry and physics can be carried out in Lab under controlled condition without much interference from the outside world. But this is not true in the case of OR study.

An operations research worker is the same position as the astronomer since the latter can observe the system but cannot manipulate.

4. Uncovering of new problems

In order to derive full benefits, continuity research must be maintained. Of course, the results of OR study pertaining a particular problem need not wait until all the connected problems are solve.

5. Improvement in the Quality of decision

OR gives bad answer to problems, otherwise, worst answer are given. That is, it can only improve the quality of solution but it may not be able to give perfect solution.

6. Use of computer

7. Quantitative solutions

for example, it will give answer like, “the cost of the company, if decision A is taken is X, if decision B is take is Y”.

8. Human factors.

Scope of Operation Research

1) Industrial management:

a) production b) product mix c) inventory control d) demand e) sale and purchase f) transportation
g) repair and maintenance h) scheduling and control

2) Defense operations:

a) army b) air force c) navy

all these further divided into sub-activity, that is, operation, intelligence administration, training.

3) Economies:

maximum growth of per capita income in the shortest possible time, by taking into consideration the national goals and restrictions impose by the country. The basic problem in most of the countries is to remove poverty and hunger as quickly as possible.

4) Agriculture section:

a) with population explosion and consequence shortage of food, every country is facing the problem of optimum allocation land to various crops in accordance with climatic conditions.
b) optimal distribution of water from the various water resource.

5) Other areas:

a) hospital b) transport c) LIC

Phases of OR

1) Formulating the problem

in formulating a problem for OR study, we must be made of the four major components.

- i) The environment
- ii) The decision maker
- iii) The objectives
- iv) Alternative course of action and constraints

2) Construction a Model

After formulating the problem, the next step is to construct mode. The mathematical model consists of equation which describes the problem.

the equation represent

- i) Effectiveness function or objective functions
- ii) Constraints or restrictions

The objective function and constraints are functions of two types of variable, controllable variable and uncontrollable variable.

A medium-size linear programming model with 50 decision variable and 25 constraints will have over 1300 data elements which must be defined.

3) Deriving solution from the model

an optimum solution from a model consists of two types of procedure: analytic and numerical.

Analytic procedures make use of two types the various branches of mathematics such as calculus or matrix algebra. Numerical procedure consists of trying various values of controllable variable in the mode, comparing the results obtained and selecting that set of values of these variables which gives the best solution.

4) Testing the model

a model is never a perfect representation of reality. But if properly formulated and correctly manipulated, it may be useful predicting the effect of changes in control variable on the over all system.

5) Establishing controls over solution

a solution derived from a model remains a solution only so long as the uncontrolled variable retain their values and the relationship between the variable does not change.

6) Implementation

OR is not merely to produce report to improve the system performance, the result of the research

must implemented.

Additional changes or modification to be made on the part of OR group because many time solutions which look feasible on paper may conflict with the capabilities and ideas of persons.

Limitations of OR

- 1) Mathematical models with are essence of OR do not take into account qualitative factors or emotional factors.
- 2) Mathematical models are applicable to only specific categories of problems
- 3) Being a new field, there is a resistance from the employees the new proposals.
- 4) Management may offer a lot of resistance due to conventional thinking.
- 5) OR is meant for men not that man is meant for it.

Difficulties of OR

- 1) The problem formulation phase
- 2) Data collection
- 3) Operations analyst is based on his observation in the past
- 4) Observations can never be more than a sample of the whole
- 5) Good solution to the problem at right time may be much more useful than perfect solutions.

Linear Programming

Requirements for LP

1. There must be a well defined objective function which is to be either maximized or minimized and which can expressed as a linear function of decision variable.
2. There must be constraints on the amount of extent of be capable of being expressed as linear equalities in terms of variable.
3. There must be alternative course of action.
4. The decision variable should be inter-related and non-negative.
5. The resource must be limited.

Some important insight:

- The power of variable and products are not permissible in the objective function as well as constraints.
- Linearity can be characterized by certain additive and multiplicative properties.

Additive example :

If a machine process job A in 5 hours and job B in 10 hours, then the time taken to process both job is 15 hours. This is however true only when the change-over time is negligible.

Multiplicative example:

If a product yields a profit of Rs. 10 then the profit earned fro the sale of 12 such products will be Rs(10 * 12) = 120. this may not be always true because of quantity discount.

- The decision variable are restricted to have integral values only.
- The objective function does not involve any constant term.

that is, $z = \sum_{j=1}^n c_j x_j + c$, that is, the optimal values are just independent of any constant c.

Examples on Formulation of the LP model**Example 1: Production Allocation Problem**

A firm produces three products. These products are processed on three different machines. The time required to manufacture one unit of each of the product and the daily capacity of the three machines are given in the table below.

Machine	Time per unit(minutes)			Machine capacity (minutes/day)
	Product 1	Product 2	Product 3	
M ₁	2	3	2	440
M ₂	4	---	3	470
M ₃	2	5	---	430

It is required to determine the daily number of units to be manufactured for each product. The profit per unit for product 1,2 and 3 is Rs. 4, Rs. 3 and Rs. 6 respectively. *It is assumed that all the amounts produced are consumed in the market.*

Formulation of Linear Programming model

Step 1: The key decision to be made is to determine the daily number of units to be manufactured for each product.

Step 2: Let x_1 , x_2 and x_3 be the number of units of products 1,2 and 3 manufactured daily.

Step 3: Feasible alternatives are the sets of values of x_1 , x_2 and x_3 where $x_1, x_2, x_3 \geq 0$. since negative number of production runs has no meaning and is not feasible.

Step 4: The objective is to maximize the profit, that is , maximize $Z = 4x_1 + 3x_2 + 6x_3$

Step 5: Express the constraints as linear equalities/inequalities in terms of variable. Here the constraints are on the machine capacities and can be mathematically expressed as,

$$2x_1 + 3x_2 + 2x_3 \leq 440,$$

$$4x_1 + 0x_2 + 3x_3 \leq 470$$

$$2x_1 + 5x_2 + 0x_3 \leq 430$$

Example 2: Advertising Media Selection Problem.

An advertising company wishes to plan its advertising strategy in three different media – television, radio and magazines. The purpose of advertising is to reach as large a number of potential customers as possible. Following data has been obtained from the market survey:

	Television	Radio	Magazine 1	Magazine 2
Cost of an advertising unit	Rs. 30,000	Rs. 20,000	Rs. 15,000	Rs. 10,000
No of potential customers reached per unit	2,00,000	6,00,000	1,50,000	1,00,000
No. of female customers reached per unit	1,50,000	4,00,000	70,000	50,000

The company wants to spend not more than Rs. 4,50,000 on advertising. Following are the further requirements that must be met:

- i) At least 1 million exposures take place among female customers
- ii) Advertising on magazines be limited to Rs. 1,50,000
- iii) At least 3 advertising units be bought on magazine I and 2 units on magazine II &
- iv) The number of advertising units on television and radio should each be between 5 and 10

Formulate an L.P model for the problem.

Solution:

The objective is to maximize the total number of potential customers.

That is, maximize $Z = (2x_1 + 6x_2 + 1.5x_3 + x_4) * 10^5$

Constraints are

- On the advertising budget $30,000x_1 + 20,000x_2 + 15,000x_3 + 10,000x_4 \leq 4,50,000$
- On number of female $1,50,000x_1 + 4,00,000x_2 + 70,000x_3 + 50,000x_4 \geq 10,00,000$
- On expense on magazine $15,000x_3 + 10,000x_4 \leq 1,50,000$
- On no. of units on magazines $x_3 \geq 3, x_4 \geq 2$
- On no. of unit on television $5 \leq x_2 \leq 10, 5 \leq x_1 \leq 10$

Example 3 :

A company has two grades of inspectors, 1 and 2 to undertake quality control inspection. At least 1,500 pieces must be inspected in an 8 hour day. Grade 1 inspector can check 20 pieces in an hour with an accuracy of 96%. Grade 2 inspector checks 14 pieces an hour with an accuracy of 92%.

The daily wages of grade 1 inspector are Rs. 5 per hour while those of grade 2 inspector are Rs. 4 per hour, any error made by an inspector costs Rs. 3 to the company. If there are, in all, 10 grade 1 inspectors and 15 grade 2 inspectors in the company, find the optimal assignment of inspectors that minimize the daily inspection cost.

Solution

Let x_1, x_2 be the inspector of grade 1 and 2.

Grade 1: $5 + 3 * 0.04 * 20$

Grade 2: $4 + 3 * 0.08 * 14$

$Z = 8*(7.4x_1 + 7.36x_2)$

$x_1 \leq 10, x_2 \leq 15$

$20 * 8 x_1 + 14 * 8 x_2 \geq 1500$

Example 4:

An oil company produces two grades of gasoline P and Q which it sells at Rs. 3 and Rs.4 per litre. The refiner can buy four different crude with the following constituents an costs:

Crude	Constituents			Price/litre
	A	B	C	
1	0.75	0.15	0.10	Rs. 2.00
2	0.20	0.30	0.50	Rs. 2.25
3	0.70	0.10	0.20	Rs. 2.50
4	0.40	0.60	0.50	Rs. 2.75

The Rs. 3 grade must have at least 55 percent of A and not more than 40% percent of C. The Rs. 4 grade must not have more than 25 percent of C. Determine how the crude should be used so as to maximize profit.

Solution:

Let x_{1p} – amount of crude 1 used for gasoline P

x_{2p} – amount of crude 2 used for gasoline P

x_{3p} – amount of crude 3 used for gasoline P

x_{4p} – amount of crude 4 used for gasoline P

x_{1q} – amount of crude 1 used for gasoline Q

x_{2q} – amount of crude 2 used for gasoline Q

x_{3q} – amount of crude 3 used for gasoline Q

x_{4q} – amount of crude 4 used for gasoline Q

The objective is to maximize profit.

that is, $3(x_{1p}+x_{2p}+x_{3p}+x_{4p}) + 4(x_{1q}+x_{2q}+x_{3q}+x_{4q}) - 2(x_{1p}+x_{1q}) - 2.25(x_{2p} + x_{2q}) - 2.50(x_{3p} + x_{3q}) - 2.75(x_{4p} + x_{4q})$

that is, maximize $Z = x_{1p}+0.75x_{2p}+0.50x_{3p}+0.25x_{4p}+2x_{1q}+1.75x_{2q}+1.50x_{3q}+1.25x_{4q}$

The constraints are:

$$0.75x_{1p}+0.20x_{2p}+.70x_{3p}+0.40x_{4p} \geq 0.55(x_{1p}+x_{2p}+x_{3p}+x_{4p}),$$

$$0.10x_{1p}+0.50x_{2p}+0.20x_{3p}+0.50x_{4p} \leq 0.40(x_{1p}+x_{2p}+x_{3p}+x_{4p}),$$

$$0.10x_{1q}+0.50x_{2q}+0.20x_{3q}+0.50x_{4q} \leq 0.25(x_{1q}+x_{2q}+x_{3q}+x_{4q})$$

Example 5:

A person wants to decide the constituents of a diet which will fulfill his daily requirements of proteins, fats and carbohydrates at the minimum cost. The choice is to be made from four different types of foods.

The yields per unit of these foods are given below

Food type	Yield per unit			Cost per unit
	Proteins	Fats	Carbohydrates	
1	3	2	6	45
2	4	2	4	40
3	8	7	7	85
4	6	5	4	65
Minimum requirement	800	200	700	

Formulate linear programming model for the problem.

Solution:

The objective is to minimize the cost

That is , $Z = Rs.(45x_1+40x_2+85x_3+65x_4)$

The constraints are on the fulfillment of the daily requirements of the constituents.

For proteins, $3x_1 + 4x_2 + 8x_3 + 6x_4 \geq 800$

For fats, $2x_1 + 4x_2 + 7x_3 + 5x_4 \geq 200$

For carbohydrates, $6x_1 + 4x_2 + 7x_3 + 4x_4 \geq 700$

Example 6:

The strategic border bomber command receives instructions to interrupt the enemy tank production. The enemy has four key plants located in separate cities, and destruction of any one plant will effectively halt the production of tanks. There is an acute shortage of fuel, which limits to supply to 45,000 litre for this particular mission. Any bomber sent to any particular city must have at least enough fuel for the round trip plus 100 litres.

The number of bombers available to the commander and their descriptions, are as follows:

Bomber type	Description	Km/litre	Number available
A	Heavy	2	40
B	Medium	2.5	30

Information about the location of the plants and their probability of being attacked by a medium bomber and a heavy bomber is given below:

Plant	Distance from base (km)	Probability of destruction by	
		A heavy bomber	A medium bomber
A	Heavy	2	40
B	Medium	2.5	30

How many of each type of bombers should be dispatched, and how should they be allocated among the four targets in order to maximize the probability of success?

Solution:

Let x_{ij} is number of bomber sent.

The objective is to maximize the probability of success in destroying at least one plant and this is equivalent to minimizing the probability of not destroying any plant. Let Q denote this probability:

then, $Q = (1 - 0.1)^{x_{A1}} \cdot (1 - 0.2)^{x_{A2}} \cdot (1 - 0.15)^{x_{A3}} \cdot (1 - 0.25)^{x_{A4}} \cdot (1 - 0.08)^{x_{B1}} \cdot (1 - 0.16)^{x_{B2}} \cdot (1 - 0.12)^{x_{B3}} \cdot (1 - 0.20)^{x_{B4}}$

here the objective function is non-linear but it can be reduced to the linear form.

Take log on both side, moreover, minimizing log Q is equivalent to maximizing $-\log Q$ or maximizing $\log 1/Q$

$$\log 1/Q = -(x_{A1} \log 0.9 + x_{A2} \log 0.8 + x_{A3} \log 0.85 + x_{A4} \log 0.75 + x_{B1} \log 0.92 + x_{B2} \log 0.84 + x_{B3} \log 0.88 + x_{B4} \log 0.80)$$

therefore, the objective is to maximize

$$\log 1/Q = -(0.0457x_{A1} + 0.09691 x_{A2} + 0.07041 x_{A3} + 0.12483 x_{A4} + 0.03623x_{B1} + 0.07572x_{B2} + 0.05538x_{B3} + 0.09691x_{B4})$$

The constraints are, due to limited supply of fuel

$$2 \times \frac{400}{2} + 100 \times A_1 + 2 \times \frac{450}{2} + 100 \times A_2 + 2 \times \frac{500}{2} + 100 \times A_3 + 2 \times \frac{600}{2} + 100 \times A_4 + 2 \times \frac{400}{2.5} + 100 \times B_1 + 2 \times \frac{450}{2.5} + 100 \times B_2 + 2 \times \frac{500}{2.5} + 100 \times B_3 + 2 \times \frac{600}{2.5} + 100 \times B_4 \leq 45,000$$

that is, $500x_{A1} + 550 x_{A2} + 600 x_{A3} + 700 x_{A4} + 420x_{B1} + 460x_{B2} + 500x_{B3} + 580x_{B4} \leq 45,000$

due to limited number of aircrafts,

$$x_{A1} + x_{A2} + x_{A3} + x_{A4} \leq 40$$

$$x_{B1} + x_{B2} + x_{B3} + x_{B4} \leq 30$$

Example 7:

A paper mill produces rolls of paper used cash register. Each roll of paper is 100m in length and can be produced in widths of 2,4,6 and 10 cm. The company’s production process results in rolls that are 24cm in width. Thus the company must cut its 24 cm roll to the desired width. It has six basic cutting alternative as follows:

The maximum demand for the four rolls is as follows

Roll width(cm)	Demand
2	2000
4	3600
6	1600
10	500

The paper mill wishes to minimize the waste resulting from trimming to size. Formulate the L.P model.

Solution:

Let $x_1, x_2, x_3, x_4, x_5, x_6$ represent the number of times each cutting alternative is to be used.

Objective is to minimize the trim losses, that is, minimize $Z = 2(x_3 + x_4 + x_5 + x_6)$

The constraints are on the market demand for each type of roll width:

- for roll width of 2 cm, $6x_1 + x_3 + 4x_6 \geq 2,000$
- for roll width of 4 cm, $3x_1 + 3x_2 + x_3 + 4x_5 \geq 3,600$
- for roll width of 6 cm, $2x_2 + x_3 + 2x_4 + x_5 + x_6 \geq 1,600$
- for roll width of 10 cm, $x_3 + x_4 \geq 500$

Graphical Solution Method

1. The collection of all feasible solutions to an LP problem constitutes a convex set whose extreme points correspond to the basic feasible solutions.
2. There are a finite number of basic feasible solutions within the feasible solution space.
3. If the convex set of the feasible solutions of the system $Ax=b, x \geq 0$, is a convex polyhedron, then at least one of the extreme points gives an optimal solution.
4. If the optimal solution occurs at more than one extreme point, then the value of the objective function will be the same for all convex combinations of these extreme points.

Extreme Point Enumeration Approach

This solution method for an LP problem is divided into five steps.

- Step1:** State the given problem in the mathematical form as illustrated in the previous chapter.
- Step2:** Graph the constraints, by temporarily ignoring the inequality sign and decide about the area of feasible solutions according to the inequality sign of the constraints. Indicate the area of feasible solutions by a shaded area, which forms a convex polyhedron.
- Step3:** Determine the coordinates of the extreme points of the feasible solution space.
- Step4:** Evaluate the value of the objective function at each extreme point.
- Step5:** Determine the extreme point to obtain the optimum (best) value of the objective function.

Types of Graphical solutions.

- Single solutions.
- Unique solutions.
- Unbounded solutions.
- Multiple solutions.
- Infeasible solutions.

Example 1.

Use the graphical method to solve the following LP problem

Maximize $Z= 15x_1+10x_2$

Subject to the constraints

$$4x_1+6x_2\leq 360$$

$$3x_1+0x_2\leq 180$$

$$0x_1+5x_2\leq 200$$

$$\text{and } X_1,x_2\geq 0$$

Solution

Step1: State the problem in the mathematical form. The given LP problem is already in mathematical form.

Step2: Plot the constraints on a graph paper and find the feasible region.

x_1 as horizontal axis, x_2 as vertical axis.

So, $4x_1+6x_2\leq 360$, treated it as equation,

$$4x_1+6x_2=360\text{.....so,}$$

If $x_1=0$, $x_2=60$

If $x_2=0$, $x_1=90$

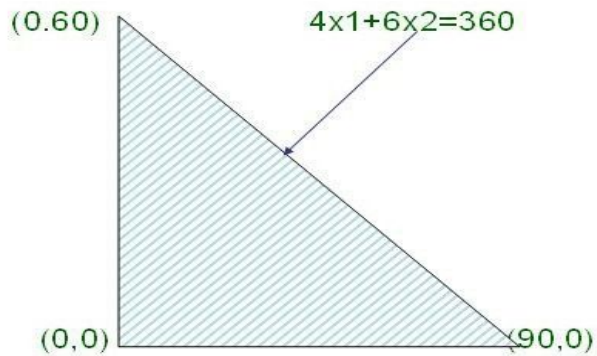

Similarly the constraints, $3x_1 \leq 180$ & $5x_2 \leq 200$

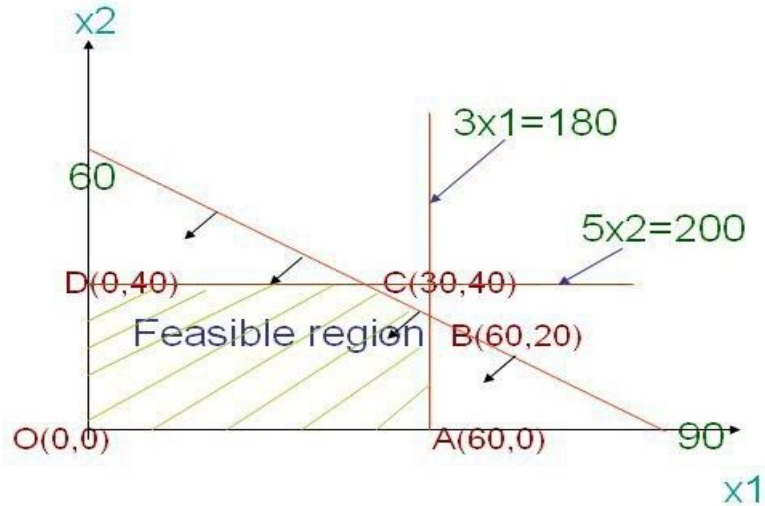

Step3: Determine coordinates of extreme points.

$O(0,0)$, $A=(60,0)$, $B=(60,20)$, $C=(30,40)$, $D=(0,40)$.

Step4: Evaluate the value of objective at extreme points.

Extreme points	Coordinates(x_1, x_2)	Objective function value $Z=15x_1+10x_2$
O	(0,0)	0
A	(60,0)	900
B	(60,20)	1100
C	(30,40)	850
D	(0,40)	400

Step5: Determine the optimal value of the objective function. From Step 4, we conclude that maximum value of $Z = 1100$ at the point B. hence $x_1=60, x_2=20$
 $Z=1100$

Single bound solutions.

Max $Z=5x_1+3x_2$

subject to: $3x_1+5x_2=15$, $x_1+2x_2=10$

Feasible region consists of single point A

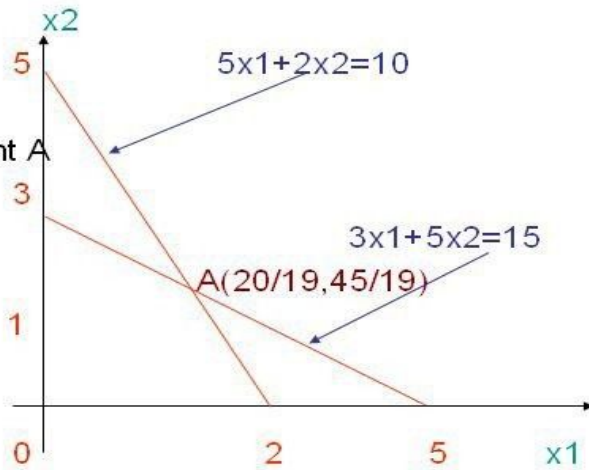

Unbounded Solution.

Max. $z=3x_1+2x_2$ subject to $x_1-x_2 \leq 1$, $x_1+x_2 \geq 3$ and $x_1, x_2 \geq 0$.

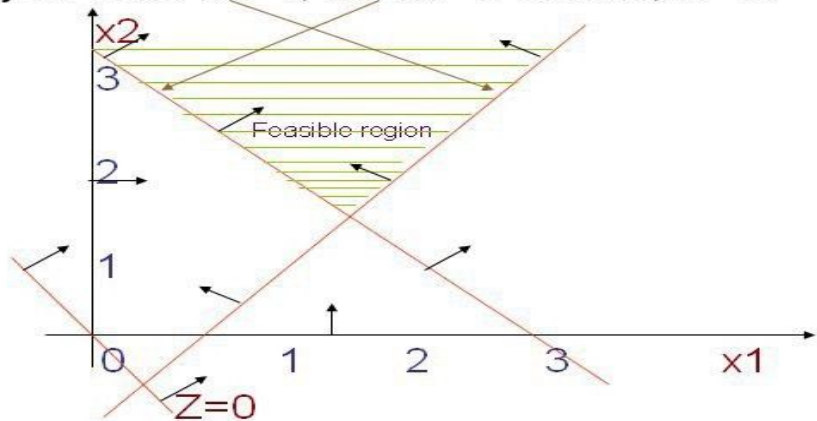

The line representing the objective function can be moved far even parallel itself in the direction of increasing z , and still have some points in the region of feasible solutions.

Multiple Solution.

Max. $z=10x_1+6x_2$ subject to the constraints:
 $5x_1+3x_2\leq 30$, $x_1+2x_2\leq 18$ and $x_1, x_2\geq 0$.

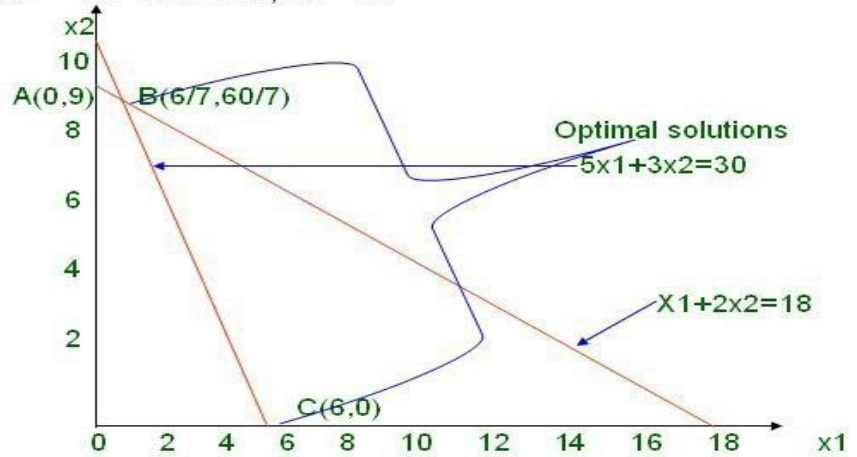

Extreme points	coordinates	Objective function value $z=300x_1+400x_2$
O	$x_1=0, x_2=0$	0
A	$x_1=0, x_2=9$	54
B	$x_1=6/7, x_2=60/7$	60
C	$x_1=6, x_2=0$	60

UNIT-II
Linear Programming Problems

Simplex Method

Example 1 (Unique solution)

$$\text{Max } Z=3x_1+5x_2+4x_3$$

Subject to

$$2x_1+3x_2 \leq 8$$

$$2x_2+5x_3 \leq 10$$

$$3x_1+2x_2+4x_3 \leq 15$$

$$x_1, x_2, x_3 \geq 0$$

Solution:

Introducing non-negative slack variables s_1, s_2 & s_3 to convert inequality constraints to equality then the LP problem becomes,

$$\text{Max } Z=3x_1+5x_2+4x_3+0s_1+0s_2+0s_3$$

Subject to

$$2x_1+3x_2+s_1=8$$

$$2x_2+5x_3+s_2=10$$

$$3x_1+2x_2+4x_3+s_3=15$$

$$x_1, x_2, x_3, s_1, s_2, s_3 \geq 0.$$

		C_j	3	5	4	0	0	0	
C_b	Basic Variables	Solution	X_1	X_2	X_3	S_1	S_2	S_3	Ratio
0	S_1	8	2	3	0	1	0	0	8/3
0	S_2	10	0	2	5	0	1	0	10/2
0	S_3	15	3	2	4	0	0	1	15/2
		Z_j	0	0	0	0	0	0	
		C_j-Z_j	3	5	4	0	0	0	

5	X ₂	8/3	2/3	1	0	1/3	0	0	--
0	S ₂	14/3	-4/3	0	5	-2/3	1	0	14/15
0	S ₃	24/3	5/3	0	4	-2/3	0	1	29/12
Z _j			10/3	5	0	5/3	0	0	
C _j -Z _j			-1/3	0	<u>4</u>	-5/3	0	0	
5	X ₂	8/3	2/3	1	0	1/3	0	0	4
4	X ₃	14/15	-4/15	0	1	-2/15	1/5	0	-ve
0	S ₃	89/15	41/15	0	0	-2/15	-4/5	1	89/41
Z _j			34/15	5	4	17/15	4/5	0	
C _j -Z _j			11/15	0	0	-	-4/5	0	
						17/15			
5	X ₂	50/41	0	1	0	15/41	8/41	-	
						10/41			
4	X ₃	62/41	0	0	1	-6/41	5/41	4/41	
3	X ₁	89/41	1	0	0	-2/41	-	15/41	
						12/41			
Z _j			3	5	4	45/41	24/41	11/41	
Z _j -C _j			0	0	0	-ve	-ve	-ve	

All $Z_j - C_j < 0$ for non-basic variable. Therefore the optimal solution is reached.

$$X_1=89/41, X_2=50/41, X_3=62/41$$

$$Z = 3*89/41+5*50/41+4*62/41 = 765/41$$

Example 2:(unbounded)

$$\text{Max } Z=4x_1+x_2+3x_3+5x_4$$

Subject to

$$4x_1-6x_2-5x_3-4x_4 \geq -20$$

$$-3x_1-2x_2+4x_3+x_4 \leq 10$$

$$-8x_1-3x_2+3x_3+2x_4 \leq 20$$

$$x_1, x_2, x_3, x_4 \geq 0.$$

Solution:

Since the RHS of the first constraints is negative , first it will be made positive by multiplying by

$-1, \rightarrow -4x_1 + 6x_2 + 5x_3 + 4x_4 \leq 20$

Introducing non-negative slack variable s_1, s_2 & s_3 to convert inequality constraint to equality then the LP problem becomes.

Max $Z = 4x_1 + x_2 + 3x_3 + 5x_4 + 0s_1 + 0s_2 + 0s_3$

Subject to

$-4x_1 + 6x_2 + 5x_3 + 4x_4 + 0s_1 = 20$

$-3x_1 - 2x_2 + 4x_3 + x_4 + s_3 = 10$

$-8x_1 - 3x_2 + 3x_3 + 2x_4 + s_4 = 20$

$x_1, x_2, x_3, x_4, s_1, s_2, s_3 \geq 0$

		C_j	4	1	3	5	0	0	0	
C_b	Variables	Solution	X_1	X_2	X_3	X_4	S_1	S_2	S_3	Ratio
0	S_1	20	-4	6	5	4	1	0	0	5
0	S_2	10	-3	-2	4	1	0	1	0	10
0	S_3	20	-8	-3	3	2	0	0	1	10
		Z_j	0	0	0	0	0	0	0	
		$C_j - Z_j$	4	1	3	5	0	0	0	
5	X_4	5	-1	3/2	5/4	1	1/4	0	0	-ve
0	S_2	5	-2	-7/2	11/4	0	-1/4	1	0	-ve
0	S_3	10	-6	-6	1/2	0	-1/2	0	1	-ve
		Z_j	-5	15/2	25/4	5	5/4	0	0	
		$C_j - Z_j$	9	-13/2	-13/4	0	-5/4	0	0	

Since all the ratio is negative, the value of incoming non-basic variable x_1 can be made as large as we like without violating condition. Therefore, the problem has an unbounded solution.

Example 3:(infinite solution)

Max $Z = 4x_1 + 10x_2$

Subject to

$2x_1 + x_2 \leq 10,$

$2x_1 + 5x_2 \leq 20,$

$2x_1 + 3x_2 \leq 18. \quad x_1, x_2 \geq 0.$

Solution:

Introduce the non-negative slack variables to convert inequality constraint to equality, then the LP problem becomes,

$$\text{Max } Z=4x_1+10x_2+0s_1+0s_2+0s_3$$

$$\text{Subject to } 2x_1+x_2+s_1=10,$$

$$2x_1+5x_2+s_2=20,$$

$$2x_1+3x_2+s_3=18.$$

$$x_1, x_2, s_1, s_2, s_3 \geq 0.$$

C _j			4	10	0	0	0	
C _b	Variables	Soln	X ₁	X ₂	S ₁	S ₂	S ₃	Ratio
0	S ₁	10	2	1	1	0	0	10
0	S ₂	20	2	5	0	1	0	4
0	S ₃	18	2	3	0	0	1	6
Z _j			0	0	0	0	0	
C _j -Z _j			4	10	0	0	0	
0	S ₁	6	8/5	0	1	-1/5	0	15/4
10	X ₂	4	2/5	1	0	1/5	0	10
0	S ₃	6	4/5	0	0	-3/5	1	15/2
Z _j			4	10	0	2	0	*x ₁ =0
C _j -Z _j			0	0	0	-2	0	X ₂ =4,Z=40
4	X ₁	15/4	1	0	5/8	-1/8	0	
10	X ₂	5/2	0	1	-1/4	1/4	0	
0	S ₃	3	0	0	-1/2	-1/2	1	
Z _j			4	10	0	0	0	
C _j -Z _j			0	0	0	0	0	

*All C_j-Z_j is either 0 or negative, it gives the optimal basic feasible solution.

But one of non-basic variable (x₁) is 0. it indicates the existence of an alternative optimal basic feasible solution.

If 2 basic feasible optimal solution are known, an infinite number of non-basic feasible optimal solution can be derived by taking any weighted average of these 2 solutions.

Variables	1	2	General solution
X_1	0	15/4	$X_1=0 \ A+15/4 \ (1-A)$
X_2	4	5/2	$X_2=4 \ A +5/2 \ (1-A)$

Minimization Case

In certain situations it is difficult to obtain an initial basic feasible solution

(a) When the constraints are of the form \leq

$$E \ (a_j \cdot x_j) \leq b_j \quad X_j \geq 0.$$

But some RHS constraints are negative. Then in this case after adding the non-negative slack variables S_i the initial solution so obtained will be $s_i=b_i$. It violates the non-negative condition of slack variable.

(b) When the constraints are of the form ' \geq '

$$E \ (a_j \cdot x_j) \geq b_j \quad X_j \geq 0.$$

In this case to convert the inequalities into equation, we are adding surplus variables, then we get the initial solution is

$$-s_i=b_i$$

$$s_i=-b_i \quad \text{which violates the non-negative condition of the variables.}$$

To solve these type of problems we are adding artificial variable. Thus the new solution to the given LP problem does not constitute a solution to the original system of equations because the 2 system of equation are not equivalent.

Thus to get back to the original problem artificial variable must be driven to 0 in the optimal solution.

There are 2 methods to eliminate these variables

- 1) Two Phase method
- 2) Big M method or Penalties.

Big- M method or the method of penalties:

In this method the artificial variables are assigned a large penalty (-M for max & +M for min. problems) in the objective function.

Example 4:

$$\text{Max } Z = 3x_1 - x_2,$$

Subject to

$$2x_1 + x_2 \geq 2$$

$$x_1 + 3x_2 \leq 3$$

$$x_2 \leq 4$$

$$x_1, x_2, x_3 \geq 0$$

Solution:

Introduce slack, surplus & artificial variable to convert inequality into equality then the LP problem becomes

$$\text{Max } Z = 3x_1 - x_2 + 0s_1 + 0s_2 + 0s_3 + 0A_1,$$

Subject to

$$2x_1 + x_2 - s_1 + A_1 = 2$$

$$x_1 + 3x_2 + s_2 = 3$$

$$x_2 + s_3 = 4$$

$$x_1, x_2, x_3, s_1, s_2, s_3, A_1 \geq 0$$

		C _j	3	-1	0	0	0	0	-M	
C _b	Variables	Soln	X ₁	X ₂	S ₁	S ₂	S ₃	A ₁		Ratio
1	A ₁	2	2	1	-1	0	0	1		1
0	S ₂	3	1	3	0	1	0	0		3
0	S ₃	4	0	1	0	0	1	0		-
		Z _j	-2M	-M	M	0	0	0	-M	
		C _j -Z _j	3+2M	-1+M	-M	0	0	0		
3	X ₁	1	1	1/2	-1/2	0	0	1/2		-
0	S ₂	2	0	5/2	1/2	1	0	-1/2		2
0	S ₃	4	0	1	0	0	1	0		-
		Z _j	3	3/2	-3/2	0	0	3/2		
		C _j -Z _j	0	-5/2		3/2	0	-		
3	X ₁	3	1	3	0	1	0	0		
0	S ₁	4	0	5	1	2	0	-1		
0	S ₃	4	0	1	0	0	1	0		
		Z _j	3	9	0	3	0	0		
		C _j -Z _j	0	-10	0	-3	0	4		

Since the value of $C_j - Z_j$ is either negative or 0 under all columns the optimal solution has been obtained.

Therefore $x_1=3$ & $x_2=0$, $Z=3x_1-x_2=3*3=9$

Example 5 (A case of no feasible solution)

Minimize $Z=x_1+2x_2+x_3$,

Subject to

$$x_1+1/2x_2+1/2x_3 \leq 1$$

$$3/2x_1+2x_2+x_3 \geq 8$$

$$x_1, x_2, x_3 \geq 0$$

Solution:

Introduce slack, surplus & artificial variable to convert inequality into equality then the LP becomes,

Max $Z^*=-x_1-2x_2-x_3+0.s_1+0s_2-MA_1$ Where $Z^*=-Z$

Subject to

$$x_1+1/2x_2+1/2x_3+s_1=1$$

$$3/2x_1+2x_2+x_3-s_2+A_1=8$$

$$x_1, x_2, x_3, s_1, s_2, A_1 \geq 0$$

			C_j	-1	-2	-1	0	0	-M	
C_b	Var	Soln	X_1	X_2	X_3	S_1	S_2	A_1	Ratio	
0	S_1	1	1	1/2	1/2	1	0	0	2	
-M	A_1	8	3/2	2	1	0	-1	1	4	
C_j			-3M/2	-2M	-M	0	M	-M		
$C_j - Z_j$			-	-	-1+M	0	-M	0		
			1+3M/2	2+2M						
-2	X_2	2	2	1	1	2	0	0		
-M	A_1	4	-5/2	0	-1	-4	-1	1		
C_j			-4+5m/2	-2	-2+M	-	M	-M		
						4+4M				
$C_j - Z_j$			3-5M/2	0	1-M	4-4M	-M	0		

Since $C_j - Z_j$ is either negative or zero & the variable column contains artificial variable A_1 is not at Zero level.

In this method there is a possibility of many cases

1. Column variable contains no artificial variable. In this case continue the iteration till an optimum solution is obtained.
2. Column variable contains at least one artificial variable AT Zero level & all $C_j - Z_j$ is either negative or Zero. In this case the current basic feasible solution is optimum through degenerate.
3. Column Variable contains at least one artificial variable not at Zero level. Also $C_j - Z_j \leq 0$. In this case the current basic feasible solution is not optimal since the objective function will contain unknown quantity M, Such a solution is called pseudo-optimum solution.

The Two Phase Method

Phase I:

Step 1: Ensure that all (bi) are non-negative. If some of them are negative, make them non-negative by multiplying both sides by -1 .

Step 2: Express the constraints in standard form.

Step 3: Add non-negative artificial variables.

Step 4: Formulate a new objective function, which consists of the sum of the artificial variables. This function is called infeasibility function.

Step 5: Using simplex method minimize the new objective function s.t. the constraints of the original problem & obtain the optimum basic feasible function.

Three cases arise: -

1. $\text{Min } Z^*$ & at least one artificial variable appears in column variable at positive level. In such a case, no feasible solution exists for the LPP & procedure is terminated.
2. $\text{Min } W=0$ & at least one artificial variable appears in column variable at Zero level. In such a case the optimum basic feasible solution to the infeasibility form may or may not be a basic feasible solution to the given original LPP. To obtain a basic feasible solution continue Phase I & try to drive all artificial variables out & then continue Phase II.
3. $\text{Min } W=0$ & no artificial variable appears in column variable. In such a case, a basic feasible solution to the original LPP has been found. Proceed to Phase II.

Phase II:

Use the optimum basic feasible solution of Phase I as a starting solution fir the original LPP. Using simplex method make iteration till an optimum basic feasible solution for it is obtained.

Note:

The new objective function is always of minimization type regardless of whether the given original LPP is of max or min type.

Example 6:

$$\text{Max } Z=3x_1+2x_2+2x_3,$$

Subject to

$$5x_1+7x_2+4x_3 \leq 7$$

$$-4x_1+7x_2+5x_3 \geq -2$$

$$3x_1+4x_2-6x_3 \geq 29/7$$

Solution:

Phase I

Step 1:

Since for the second constraint $b_2=-2$, multiply both sides by -1 transform it to

$$4x_1-7x_2-5x_3 \leq 2$$

Step 2:

Introduce slack variables

$$5x_1+7x_2+4x_3+s_1=7$$

$$4x_1-7x_2-5x_3+s_2=2$$

$$3x_1+4x_2-6x_3+s_3=29/7$$

Step 3:

Putting $x_1=x_2=x_3=0$, we get $s_1=7, s_2=2, s_3=-29/7$ as initial basic feasible solution.

However it is not the feasible solution as s_3 is negative.

Therefore introduce artificial variable A_1 from the above Constraints can be written as

$$5x_1+7x_2+4x_3+s_1=7$$

$$4x_1-7x_2-5x_3+s_2=2$$

$$3x_1+4x_2-6x_3-s_3+A_1=29/7$$

The new objective function is $Z^*=A_1$

		C _j	0	0	0	0	0	0	1	
C _B	Var	Soln	X ₁	X ₂	X ₃	S ₁	S ₂	S ₃	A ₁	Ratio
0	S ₁	7	5	7	4	1	0	0	0	1
0	S ₂	2	4	-7	-5	0	1	0	0	-
1	A ₁	29/7	3	4	-6	0	0	-1	1	29/28
		C _j	3	4	-6	0	0	-1	1	

		$C_j - Z_j$	-3	-4	6	0	0	1	0	
0	X_2	1	5/7	1	4/7	1/7	0	0	0	7/5
0	S_2	9	9	0	-1	1	1	0	0	1
1	A_1	1/7	1/7	0	-58/7	-4/7	0	-1	1	1
C_j			1/7	0	-58/7	-4/7	0	-1	1	
$C_j - Z_j$			-1/7	0	58/7	4/7	0	1	0	
0	X_2	2/7	0	1	294/7	3	0	5	-5	
0	S_2	0	0	0	521	37	1	63	-63	
0	X_1	1	1	0	-58	-4	0	-7	7	
C_j			0	0	0	0	0	0	0	
$C_j - Z_j$			0	0	0	0	0	0	1	

Since all $C_j - Z_j \geq 0$ the objective function is 0 & no artificial variable appears in column variable the table yields the basic feasible solution to the original problem.

Phase II

The original objective function is

$$\text{Max } Z = 3x_1 + 2x_2 + 2x_3 + 0.s_1 + 0.s_2 + 0.s_3$$

		C_j	0	0	0	0	0	0	
C_B	Var	Soln	X_1	X_2	X_3	S_1	S_2	S_3	Ratio
0	X_2	2/7	0	1	42	3	0	5	1/147
0	S_2	0	0	0	521	37	1	63	0
3	X_3	1	1	0	-58	-4	0	-7	-
C_j			3	2	-90	-6	0	-11	
$C_j - Z_j$			0	0	92	6	0	11	
2	X_2	2/7	0	1	0	59/521	-	-	
							42/521	41/521	
2	X_3	0	0	0	1	37/521	1/521	63/521	
3	X_1	1	1	0	0	62/521	58/521	7/521	
C_j			3	2	2	278/521	92/521	65/521	
$C_j - Z_j$			0	0	0	-	-	-	
						278/521	92/521	65/521	

$$x_1=1, x_2=2/7, x_3=0$$

$$\underline{z=25/7}$$

Example 7:

(Unconstrained variables)

$$\text{Min } Z=2x_1+3x_2$$

Subject to

$$x_1-2x_2 \leq 0$$

$$-2x_1+3x_2 \geq -6$$

x_1, x_2 unrestricted.

Solution:

The RHS of 2nd constraint is -ve so multiply both sides by -1 we get

$$2x_1-3x_2 \leq 6$$

as variable x_1 & x_2 are unrestricted we express them as

$$x_1=y_1-y_2$$

$$x_2=y_3-y_4$$

where $y_i \geq 0 \quad i=1,2,3,4$

thus the given problem is transformed to

$$\text{min } Z=2y_1-2y_2+3y_3-3y_4$$

$$\text{s.t. } y_1-y_2-2y_3+2y_4 \leq 0$$

$$-2y_1-2y_2+3y_3-3y_4 \leq 6$$

introduce slack variables we get

$$\text{Min } Z= 2y_1-2y_2+3y_3-3y_4+0s_1+0s_2$$

Subject to

$$y_1-y_2-2y_3+2y_4+0s_1 \leq 0$$

$$-2y_1-2y_2+3y_3-3y_4+0s_2 \leq 6$$

where all variables are ≥ 0

		C _j	2	-2	3	-3	0	0	
C _B	Var	Soln	Y ₁	Y ₂	Y ₃	Y ₄	S ₁	S ₂	Ratio
0	S ₁	0	1	-1	-2	2	1	0	0
0	S ₂	6	2	-2	-3	3	0	1	2
		C _j	0	0	0	0	0	0	

		$C_j - Z_j$	2	-2	3	-3	0	0	
-3	Y_4	0	$\frac{1}{2}$	$-\frac{1}{2}$	-1	1	$\frac{1}{2}$	0	-
0	S_2	6	$\frac{1}{2}$	$-\frac{1}{2}$	0	0	$-\frac{3}{2}$	1	-
		C_j	$-\frac{3}{2}$	$\frac{3}{2}$	3	-3	$\frac{3}{2}$	0	
		$C_j - Z_j$	$\frac{3}{2}$	$-\frac{7}{2}$	0	0	$-\frac{3}{2}$	0	

All the ratios are -ve → that the value of the incoming non-basic variable y_2 can be made as large as possible without violating the constraint. This problem has unbounded solution & the iteration stops here.

Note:

If the minimum ratio is equal to for 2 or more rows, arbitrary selection of 1 of these variables may result in 1 or more variable becoming 0 in the next iteration & the problem is said to degenerate.

These difficulties maybe overcome by applying the following simple procedure called perturbation method.

1. Divide each element in the tied rows by the positive co-efficient of the key column in that row
2. Compare the resulting ratios, column-by-column 1st in the identity & then in the body from left to right.
3. The row which first contains the smallest algebraic ratio contains the outgoing variable.

Linear programming - sensitivity analysis

Recall the production planning problem concerned with four variants of the same product which we formulated [before](#) as an LP. To remind you of it we repeat below the problem and our formulation of it.

Production planning problem

A company manufactures four variants of the same product and in the final part of the manufacturing process there are assembly, polishing and packing operations. For each variant the time required for these operations is shown below (in minutes) as is the profit per unit sold.

	Assembly	Polish	Pack	Profit (£)
Variant 1	2	3	2	1.50
2	4	2	3	2.50
3	3	3	2	3.00
4	7	4	5	4.50

- Given the current state of the labour force the company estimate that, each year, they have 100000 minutes of assembly time, 50000 minutes of polishing time and 60000 minutes of

packing time available. How many of each variant should the company make per year and what is the associated profit?

- Suppose now that the company is free to decide how much time to devote to each of the three operations (assembly, polishing and packing) within the total allowable time of 210000 (= 100000 + 50000 + 60000) minutes. How many of each variant should the company make per year and what is the associated profit?

Production planning solution Variables

Let: x_i be the number of units of variant i ($i=1,2,3,4$) made per year

T_{ass} be the number of minutes used in assembly per year

T_{pol} be the number of minutes used in polishing per year

T_{pac} be the number of minutes used in packing per year

where $x_i \geq 0$ $i=1,2,3,4$ and $T_{ass}, T_{pol}, T_{pac} \geq 0$

Constraints

(a) operation time definition

$$T_{ass} = 2x_1 + 4x_2 + 3x_3 + 7x_4 \text{ (assembly)}$$

$$T_{pol} = 3x_1 + 2x_2 + 3x_3 + 4x_4 \text{ (polish)}$$

$$T_{pac} = 2x_1 + 3x_2 + 2x_3 + 5x_4 \text{ (pack)}$$

(b) operation time limits

The operation time limits depend upon the situation being considered. In the first situation, where the maximum time that can be spent on each operation is specified, we simply have:

$$T_{ass} \leq 100000 \text{ (assembly)}$$

$$T_{pol} \leq 50000 \text{ (polish)}$$

$$T_{pac} \leq 60000 \text{ (pack)}$$

In the second situation, where the only limitation is on the total time spent on all operations, we simply have:

$$T_{ass} + T_{pol} + T_{pac} \leq 210000 \text{ (total time)}$$

Objective

Presumably to maximise profit - hence we have

$$\text{maximise } 1.5x_1 + 2.5x_2 + 3.0x_3 + 4.5x_4$$

which gives us the complete formulation of the problem.

A summary of the input to the computer [package](#) for the first situation considered in the question (maximum time that can be spent on each operation specified) is shown below.

Maximize	$1.5X_1+2.5X_2+3X_3+4.5X_4$
C1	$2X_1+4X_2+3X_3+7X_4-1T_{ass}=0$
C2	$3X_1+2X_2+3X_3+4X_4-1T_{pol}=0$
C3	$2X_1+3X_2+2X_3+5X_4-1T_{pac}=0$
C4	$1T_{ass}\leq 100000$
C5	$1T_{pol}\leq 50000$
C6	$1T_{pac}\leq 60000$
Integer:	
Binary:	
Unrestricted:	
X1	$\geq 0, \leq M$
X2	$\geq 0, \leq M$
X3	$\geq 0, \leq M$
X4	$\geq 0, \leq M$
T_{ass}	$\geq 0, \leq M$
T_{pol}	$\geq 0, \leq M$
T_{pac}	$\geq 0, \leq M$

The solution to this problem is also shown below.

	Decision Variable	Solution Value	Unit Cost or Profit c(j)	Total Contribution	Reduced Cost	Basis Status	Allowable Min. c(j)	Allowable Max. c(j)
1	X1	0	1.5000	0	-1.5000	at bound	-M	3.0000
2	X2	16,000.0000	2.5000	40,000.0000	0	basic	2.3571	4.5000
3	X3	6,000.0000	3.0000	18,000.0000	0	basic	2.5000	3.7500
4	X4	0	4.5000	0	-0.2000	at bound	-M	4.7000
5	T _{ass}	82,000.0000	0	0	0	basic	-0.2500	1.0000
6	T _{pol}	50,000.0000	0	0	0	basic	-0.8000	M
7	T _{pac}	60,000.0000	0	0	0	basic	-0.3000	M
	Objective	Function	(Max.) =	58,000.0000				
	Constraint	Left Hand Side	Direction	Right Hand Side	Slack or Surplus	Shadow Price	Allowable Min. RHS	Allowable Max. RHS
1	C1	0	=	0	0	0	-18,000.0000	82,000.0000
2	C2	0	=	0	0	0.8000	-10,000.0000	40,000.0000
3	C3	0	=	0	0	0.3000	-26,666.6700	15,000.0000
4	C4	82,000.0000	<=	100,000.0000	18,000.0000	0	82,000.0000	M
5	C5	50,000.0000	<=	50,000.0000	0	0.8000	40,000.0000	90,000.0000
6	C6	60,000.0000	<=	60,000.0000	0	0.3000	33,333.3400	75,000.0000

We can see that the optimal solution to the LP has value 58000 (£) and that $T_{ass}=82000$, $T_{pol}=50000$, $T_{pac}=60000$, $X_1=0$, $X_2=16000$, $X_3=6000$ and $X_4=0$.

This then is the LP solution - but it turns out that the simplex algorithm (as a *by-product* of solving the LP) gives some useful information. This information relates to:

- changing the objective function coefficient for a variable
- forcing a variable which is currently zero to be non-zero
- changing the right-hand side of a constraint.

We deal with each of these in turn, and note here that the analysis presented below ONLY applies for a single change, if two or more things change then we effectively need to resolve the LP.

- suppose we vary the coefficient of X_2 in the objective function. How will the LP optimal solution change?

Currently $X_1=0$, $X_2=16000$, $X_3=6000$ and $X_4=0$. The Allowable Min/Max $c(i)$ columns above tell us that, provided the coefficient of X_2 in the objective function lies between 2.3571 and 4.50, the values of the variables in the optimal LP solution will remain unchanged. Note though that the actual optimal solution value will change.

In terms of the original problem we are effectively saying that the decision to produce 16000 of variant 2 and 6000 of variant 3 remains optimal even if the profit per unit on variant 2 is not actually 2.5 (but lies in the range 2.3571 to 4.50).

Similar conclusions can be drawn about X_1 , X_3 and X_4 .

In terms of the underlying simplex algorithm this arises because the current simplex basic solution (vertex of the feasible region) remains optimal provided the coefficient of X_2 in the objective function lies between 2.3571 and 4.50.

- for the variables, the Reduced Cost column gives us, for each variable which is currently *zero* (X_1 and X_4), an *estimate* of how much the objective function will change if we make that variable non-zero.

Hence we have the table

Variable	X_1	X_4
Opportunity Cost	1.5	0.2
New value (= or \geq)	$X_1=A$	$X_4=B$
	or $X_1 \geq A$	$X_4 \geq B$
Estimated objective function change	1.5A	0.2B

The objective function will *always* get worse (go down if we have a maximisation problem, go up if we have a minimisation problem) by *at least* this estimate. The larger A or B are the more inaccurate this estimate is of the exact change that would occur if we were to resolve the LP with the corresponding constraint for the new value of X_1 or X_4 added.

Hence if exactly 100 of variant one were to be produced what would be your estimate of the new objective function value?

Note here that the value in the Reduced Cost column for a variable is often called the "*opportunity cost*" for the variable.

Note here than an alternative (and equally valid) interpretation of the reduced cost is the amount by which the objective function coefficient for a variable needs to change before that variable will become non-zero.

Hence for variable X_1 the objective function needs to change by 1.5 (increase since we are maximising) before that variable becomes non-zero. In other words, referring back to our original situation, the profit per unit on variant 1 would need to need to increase by 1.5 before it would be profitable to produce any of variant 1. Similarly the profit per unit on variant 4 would need to increase by 0.2 before it would be profitable to produce any of variant 4.

- for each constraint the column headed Shadow Price tells us *exactly* how much the objective function will change if we change the right-hand side of the corresponding constraint within the limits given in the Allowable Min/Max RHS column.

Hence we can form the table

Constraint	Assembly	Polish	Pack
Opportunity Cost (ignore sign)	0	0.80	0.30
Change in right-hand side	a	b	c
Objective function change	0	0.80b	0.30c
Lower limit for right-hand side	82000	40000	33333.34
Current value for right-hand side	100000	50000	60000
Upper limit for right-hand side	-	90000	75000

For example for the polish constraint, provided the right-hand side of that constraint remains between 40000 and 90000 the objective function change will be exactly 0.80[change in right-hand side from 50000].

The direction of the change in the objective function (up or down) depends upon the direction of the change in the right-hand side of the constraint and the nature of the objective (maximise or minimise).

To decide whether the objective function will go up or down use:

- constraint more (less) restrictive after change in right-hand side implies objective function worse (better)
- if objective is maximise (minimise) then worse means down (up), better means up (down)

Hence

- if you had an extra 100 hours to which operation would you assign it?
- if you had to take 50 hours away from polishing or packing which one would you choose?
- what would the new objective function value be in these two cases?

The value in the column headed Shadow Price for a constraint is often called the "*marginal value*" or "*dual value*" for that constraint.

Note that, as would seem logical, if the constraint is loose the shadow price is zero (as if the constraint is loose a small change in the right-hand side cannot alter the optimal solution).

Comments

- Different LP packages have different formats for input/output but the same information as discussed above is still obtained.
- You may have found the above confusing. Essentially the interpretation of LP output is something that comes with practice.
- Much of the information obtainable (as discussed above) as a by-product of the solution of the LP problem can be useful to management in estimating the effect of changes (e.g. changes in costs, production capacities, etc) *without* going to the hassle/expense of resolving the LP.
- This sensitivity information gives us a measure of how *robust* the solution is i.e. how sensitive it is to changes in input data.

Note here that, as mentioned above, the analysis given above relating to:

- changing the objective function coefficient for a variable; and
- forcing a variable which is currently zero to be non-zero; and
- changing the right-hand side of a constraint

is only valid for a single change. If two (or more) changes are made the situation becomes more complex and it becomes advisable to resolve the LP.

Linear programming sensitivity example

Consider the linear program:

maximise

$$3x_1 + 7x_2 + 4x_3 + 9x_4$$

subject to

$$x_1 + 4x_2 + 5x_3 + 8x_4 \leq 9 \quad (1)$$

$$x_1 + 2x_2 + 6x_3 + 4x_4 \leq 7 \quad (2)$$

$$x_i \geq 0 \quad i=1,2,3,4$$

Solve this linear program using the computer package.

- what are the values of the variables in the optimal solution?
- what is the optimal objective function value?
- which constraints are tight?
- what would you estimate the objective function would change to if:
 - we change the right-hand side of constraint (1) to 10
 - we change the right-hand side of constraint (2) to 6.5
 - we add to the linear program the constraint $x_3 = 0.7$

Solving the problem using the [package](#) the solution is:

	Decision Variable	Solution Value	Unit Cost or Profit $c(j)$	Total Contribution	Reduced Cost	Basis Status	Allowable Min. $c(j)$	Allowable Max. $c(j)$
1	X1	5.0000	3.0000	15.0000	0	basic	1.7500	3.5000
2	X2	1.0000	7.0000	7.0000	0	basic	6.0000	12.0000
3	X3	0	4.0000	0	-13.5000	at bound	-M	17.5000
4	X4	0	9.0000	0	-5.0000	at bound	-M	14.0000
	Objective	Function	(Max.) =	22.0000				
	Constraint	Left Hand Side	Direction	Right Hand Side	Slack or Surplus	Shadow Price	Allowable Min. RHS	Allowable Max. RHS
1	C1	9.0000	<=	9.0000	0	0.5000	7.0000	14.0000
2	C2	7.0000	<=	7.0000	0	2.5000	4.5000	9.0000

Reading from the printout given above we have:

- the variable values are $X_1=5$, $X_2=1$, $X_3=0$, $X_4=0$
- the optimal objective function value is 22.0
- both constraints are tight (have no slack or surplus). Note here that the (implicit) constraints ensuring that the variables are non-negative ($x_i \geq 0$ $i=1,2,3,4$) are (by convention) not considered in deciding which constraints are tight.
- objective function change = $(10-9) \times 0.5 = 0.5$. Since the constraint is less restrictive the objective function will get better. Hence as we have a maximisation problem it will increase. Referring to the Allowable Min/Max RHS column we see that the new value (10) of the right-hand side of constraint (1) is within the limits specified there so that the new value of the objective function will be *exactly* $22.0 + 0.5 = 22.5$
- objective function change = $(7-6.5) \times 2.5 = 1.25$. Since we are making the constraint more restrictive the objective function will get worse. Hence as we have a maximisation problem it will decrease. As for (1) above the new value of the right-hand side of constraint (2) is within the limits in the Minimum/Maximum RHS column and so the new value of the objective function will be *exactly* $22.0 - 1.25 = 20.75$
- objective function change = $0.7 \times 13.5 = 9.45$. The objective function will get worse (decrease) since changing any variable which is zero at the linear programming optimum to a non-zero value always makes the objective function worse. We *estimate* that it will decrease to $22.0 - 9.45 = 12.55$. Note that the value calculated here is only an *estimate* of the change in the objective function value. The actual change may be different from the estimate (but will always be \geq this estimate).

Note that we can, if we wish, explicitly enter the four constraints $x_i \geq 0$ $i=1,2,3,4$. Although this is unnecessary (since the package automatically assumes that each variable is ≥ 0) it is not incorrect. However, it may alter some of the solution figures - in particular the Reduced Cost figures may be different. This illustrates that such figures are *not* necessarily uniquely defined at the linear programming optimal solution.

UNIT-III

Transportation Model

Find the optimal solution for the following given TP model.

		Distribution center (to)				Supply
		1	2	3	4	
Plants (From)	2	2	3	11	7	6
	1	1	0	6	1	1
	5	5	8	15	9	10
Requirements		7	5	3	2	

Note:

If the supply & demand are equal then it is called balanced otherwise unbalanced.

Non-Degenerate:

A basic feasible solution to a (m x n) transportation problem that contains exactly (m+n-1) allocation in independent position.

Degenerate:

A basic feasible solution that contains less than m+n-1 non-negative allocations

Find Basic Feasible Solution

1) North West Corner Rule

Start in the northwest corner

- If $D_1 < S_1$, then set x_1 equal to D_1 & proceed horizontally.
- If $D_1 = S_1$, then set x_1 equal to D_1 & proceed diagonally.
- If $D_1 > S_1$, then set x_1 equal to S_1 & proceed vertically.

2	3	11	7	6	0
6					
1	0	6	1	1	0
1					
5	8	15	9		
	5	3	2		

10 5 3 2

	7	5	3	2
6	0	0	0	
X				

it can be easily seen that the proposed solution is a feasible solution since all the supply & requirement constraints are fully satisfied. In this method, allocations have been made without any consideration of cost of transformation associated with them.

Hence the solution obtained may not be feasible or the best solution.

The transport cost associate with this solution is :

$$\begin{aligned}
 Z &= \text{Rs } (2 \cdot 6 + 1 \cdot 1 + 8 \cdot 5 + 15 \cdot 3 + 9 \cdot 2) \cdot 100 \\
 &= \text{Rs } (12 + 1 + 40 + 45 + 18) \cdot 100 \\
 &= \text{Rs } 11600
 \end{aligned}$$

2) Row Minima Method

This method consists in allocating as much as possible in the lowest cost cell of the 1st row so that either the capacity of the 1st plant is exhausted or the requirement at the jth distribution center is satisfied or both

Three cases arises:

- If the capacity of the 1st plant is completely exhausted, cross off the 1st row & proceed to the 2nd row.
- If the requirement of the jth distribution center is satisfied, cross off the jth column & reconsider the 1st row with the remaining capacity.
- If the capacity of the 1st plant as well as the requirement at jth distribution center are completely satisfied, make a 0 allocation in the 2nd lowest cost cell of the 1st row. Cross of the row as well as the jth column & move down to the 2nd row.

2	3	11	7	
6				6 0
1	0	6	1	
	1			1 0
5	8	15	9	
1	4	3	2	10 9 5 3 0
7	5	3	2	

$$\begin{array}{cccc}
 1 & 0 & 0 & 0 \\
 0 & & &
 \end{array}$$

$$\begin{aligned}
 Z &= 100 * (6*2+0*1+5*1+8*4+15*3+9*2) \\
 &= 100 * (12+0+5+32+45+18) = 100 * 112 = 11200
 \end{aligned}$$

3) Column Minima Method

	2	3	11	7	
6	6				/ 0
	1	0	6	1	
	1				/ 1 0
	5	8	15	9	
		5	3	2	
10	5	3	2	0	

$$\begin{array}{cccc}
 7 & 5 & 3 & 2 \\
 6 & 0 & 0 & 0 \\
 1 & & & \\
 0 & & &
 \end{array}$$

$$\begin{aligned}
 Z &= 2*6+1*1+5*0+5*8+15+18 \\
 &= 12+1+40+45+18 \\
 &= 116
 \end{aligned}$$

4) Least Cost Method

This method consists of allocating as much as possible in the lowest cost cell/cells & then further allocation is done in the cell with the 2nd lowest cost.

2	3	11	7	
6				6 0
1	0	6	1	
	1			
5	8	15	9	1 0
1	4	3	2	

10 9 5 2 0
 7 5 3 2
 1 4 0 0
 0 0

$$Z = 12 + 0 + 5 + 32 + 45 + 18 = 112$$

5. Vogel's Approximation Method

2	3	11	7	
1	5			6 1 0 [1] [1] [5] *
1	0	6	1	1 0 [1] * * *
			1	
5	8	15	9	10 7 8 0 [3] [3] [4] [4]
6		3	1	

~~7~~ ~~5~~ 3 2
~~6~~ 0 0 1
 0 0
 [1] [3] [5] [6]
 [3] [5] [4] [2]
 [3] * [4] [2]
 [5] [8] [4] [9]

$$z = 2 + 15 + 1 + 30 + 45 + 9$$

$$= 102$$

Perform Optimality Test

An optimality test can, of course, be performed only on that feasible solution in which:

- (a) Number of allocations is $m+n-1$
- (b) These $m+n-1$ allocations should be in independent positions.

A simple rule for allocations to be in independent positions is that it is impossible to travel from any allocation, back to itself by a series of horizontal & vertical jumps from one occupied cell to another, without a direct reversal of route.

Now test procedure for optimality involves the examination of each vacant cell to find whether or not making an allocation in it reduces the total transportation cost.

The 2 methods usually used are:

- (1) Stepping-Stone method
- (2) The modified distribution (MODI) method

1. The Stepping-Stone Method

Let us start with any arbitrary empty cell (a cell without allocation), say (2,2) & allocate +1 unit to this cell, in order to keep up the column 2 restriction (-1) must be allocated to the cell (1,2) and keep the row 1 restriction, +1 must be allocated to cell (1,1) and consequently (-1) must be allocated to cell (2,1).

2 +1	3 -1	11	7
1	5		
1 -1	0 +1	6	1
			1
5	8	15	9
6		3	1

The net change in the transportation cost is

$$= 0*1 - 3*1 + 2*1 - 1*1$$

$$= -2$$

Naturally, as a result of above perturbation, the transportation cost decreased by -2.

The total number of empty cell will be $m \cdot n - (m+n-1) = (m-1)(n-1)$

Such cell evaluations that cell evaluation is negative, that the solution under improved.

	0	1	10	4
2			12	6
-3	-3	-2	7	
5		6		

must be calculated. If any the cost can be reduced. So consideration can be

2. The Modified method or u-v method

Distribution (MODI)

Step 1: Set up the cost matrix containing the costs associated with the cells for which allocations have been made.

	$V_1=0$	$v_2=0$	$v_3=0$	$v_4=0$
$u_1=2$	2	3		
$u_2=3$				1
$u_3=5$	5		15	9

Step 2: Enter a set of number V_j across the top of the matrix and a set of number U_i across the left side so that their sums equal to the costs entered in Step 1.

Thus,

$u_1 + v_1 = 2$

$u_3 + v_1 = 5$

$u_1 + v_2 = 3$

$u_3 + v_3 = 15$

$u_2 + v_4 = 1$

Let $v_1 = 0$

→ $u_1 = 2 ; u_2 = -3 ;$

2	$u_3 + v_4 = 9$		
			1
5		15	9

$u_1 = 2 ; v_2 = 1 ; v_3 = 10 ; v_4 = 4$

Step 3: Fill the vacant cells with the sum of u_i & v_j

Step 4: Subtract the cell values of the matrix of Step 3 from original cost matrix.

		11-12	7-6
1+3	0+2	6-7	
	8-6		

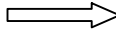

The resulting matrix is called **cell evaluation matrix**.

step5: If any of the cell evaluations are negative the solution is not optimal.

		-1	1
4	2	-1	
	2		

basic feasible

Iterate towards optimal solution

Substep1: From the cell evaluation matrix, identify the cell with the **most negative entry**.

Let us choose cell (1,3).

Substep2: write initial feasible solution.

1	5	+	
-			1
6		3	
+		-	

Check mark (✓) the empty cell for which the cell evaluation is negative. This cell is chosen in substep1 & is called identified cell.

Substep3: Trace a path in this matrix consisting of a series of alternately horizontal & vertical lines. The path begins & terminates in the identified cell. All corners of the path lie in the cells for which allocations have been made. The path may skip over any number of occupied or vacant cells.

Substep4: Mark the identified cells as positive and each occupied cell at the corners of the path alternatively negative & positive & so on.

Note :In order to maintain feasibility locate the occupied cell with minus sign that has the smallest allocation

Substep5: Make a new allocation in the identified cell.

1-1=0	5	1	
			1
7		2	1

2	3 5	11 1	7
1	0	6	1 1
5 7	8	15 2	5 1

The total cost of transportation for this 2nd feasible solution is

$$=Rs (3*5+11*1+1*1+7*5+2*15+1*9)$$

$$=Rs (15+11+1+35+30+9)$$

$$=Rs 101$$

Check for optimality

In the above feasible solution

- a) number of allocations is (m+n-1) is 6
- b) these (m+ n – 1)allocation are independent positions.

Above conditions being satisfied, an optimality test can be performed.

MODI method

Step1: Write down the cost matrix for which allocations have been made.

Step2: Enter a set of number V_j across the top of the matrix and a set of number U_i across the left side so that their sums equal to the costs entered in Step1.

Thus,

$$u_1+v_2=3$$

$$u_3+v_1=5$$

$$u_1 + v_3 = 11$$

$$u_3 + v_3 = 15$$

$$u_2 + v_4 = 1$$

$$u_3 + v_4 = 9$$

Let $v_1 = 0$

$$\rightarrow u_1 = 1 ; u_2 = -3 ; u_3 = 5 ; v_2 = 2 ; v_3 = 10 ; v_4 = 4$$

	v_1	v_2	v_3	v_4
u_1		3	11	
u_2				1
u_3	5		15	9

Step3: Fill the vacant cells with the sums of v_j & u_i

	$v_1=0$	$v_2=2$	$v_3=10$	$v_4=4$
$U_1=1$	1			5
$U_2=-3$	-3	-1	7	
$U_3=5$		7		

Step4: Subtract from the original matrix.

2-1			7-5	→	1			2
1+3	0+1	6-7			4	1	-1	
	8-7					-1		

Step5: Since one cell is negative, 2nd feasible solution is not optimal.

Iterate towards an optimal solution

Substep1: Identify the cell with most negative entry. It is the cell (2,3).

Substep2: Write down the feasible solution.

	5	1	
		+	1 -
7		2 -	1 +

Substep3: Trace the path.

Substep4: Mark the identified cell as positive & others as negative alternatively.

Substep5:

	5	1	
--	---	---	--

Third feasible solutions

		1	
7		1	2

$$Z = (5 \times 3 + 1 \times 11 + 1 \times 6 + 1 \times 15 + 2 \times 9 + 7 \times 5)$$

$$= 100$$

Test for optimality

In the above feasible solutions

- a) number of allocation is $(m+n-1)$ that is, 6
- b) these $(m+n-1)$ are independent.

Step1: setup cost matrix

	3	11	
		6	
5		15	9

Step2: Enter a set of number V_j across the top of the matrix and a set of number U_i across the left side so that their sums equal to the costs entered in Step1.

Thus,

$$\begin{aligned} u_1 + v_2 &= 3 & u_3 + v_1 &= 5 \\ u_1 + v_3 &= 11 & u_3 + v_3 &= 15 \\ u_2 + v_3 &= 6 & u_3 + v_4 &= 9 \end{aligned}$$

let $v_1 = 0, u_3 = 5, u_2 = -4, u_1 = 1, v_2 = 2, v_3 = 10, v_4 = 4$

the resulting matrix is

	0	2	10	4
1	1			5
-4	-4	-2		0
5		7		

Subtract from original cost matrix, we will get cell evaluation matrix

1			2
5	2		1

	1		
--	---	--	--

Since all the cells are positive, the third feasible solution is optimal solution.

Assignment Problem

1. Four different jobs can be done on four different machines. The set up and down time costs are assumed to be prohibitively high for changeovers. The matrix below gives the cost in rupees of producing job I on machine j

		MACHINES			
		M1	M2	M3	M4
JOBS	J1	5	7	11	6
	J2	8	5	9	6
	J3	4	7	10	7
	J4	10	4	8	3

How should the jobs be assigned to the various m/c so that the total cost is minimized?

Step 1: Prepare a square matrix: Since the solution involves a square matrix, this step is not necessary.

Step 2: Reduce the matrix: This involves the following substeps.

Substep 1: In the effectiveness matrix, subtract the minimum element of each row from all the elements of the row. See if there is atleast one zero in each row and in each column. If it is so, stop here. If it is so, stop here. If not proceed to substep 2.

	M1	M2	M3	M4
J1	0	2	6	1
J2	3	0	4	1
J3	0	3	6	3
J4	7	1	5	0

Matrix after substep 1
(contains no zero in column 3)

Substep 2:

Now subtract the minimum element of each column from all the elements of the column.

	M1	M2	M3	M4
J1	0	2	2	1
J2	3	0	0	1
J3	0	3	2	3
J4	7	1	1	0

Step 3 (Test for optimality)

Check if optimal assignment can be made in the current solution or not.

Substep 1: Examine rows successively until a row with exactly one unmarked zero is found. Mark this zero indicating that an assignment will be made there. Mark all other zeroes in the same column showing that they cannot be used for making other assignments. Proceed in this manner until all rows have been examined.

	M1	M2	M3	M4
J1	0	2	2	1
J2	3	0	0	1
J3	0	3	2	3
J4	7	1	1	0

SUBSTEP 2: Next examine columns for single unmarked zeroes and mark them suitably.

SUBSTEP 3: In the present example, after following substeps 1 and 2 we find that their repetition is unnecessary and also row 3 and column 3 are without any assignments. Hence we proceed as follows to find the minimum number of lines crossing all zeroes.

SUBSTEP 4: Mark the rows for which assignment has not been made. In our problem it is the third row.

SUBSTEP 5: Mark columns (not already marked) which have zeroes in marked rows. Thus column 1 is marked.

SUBSTEP 6: Mark rows(not already marked) which have assignments in marked columns. Thus row 1 is marked.

SUBSTEP 7: Repeat steps 5 and 6 until no more marking is possible. In the present case this repetition is not necessary.

	M1	M2	M3	M4	
J1	0	2	2	1	✓
J2	3	0	0	1	
J3	0	3	2	3	✓
J4	7	1	1	0	

✓

SUBSTEP 8: Draw lines through all unmarked rows and through all marked columns. This gives the minimum number of lines crossing all zeroes.

If the procedure is correct, there will be as many lines as the number of assignments. In this example, number of such lines is 3 which is less than n ($n=4$). Hence optimal assignment is not possible in the current solution

STEP 4:

Examine the elements that do not have line through them. Select the smallest of these elements and subtract it from all the elements that do not have a line through them.

Add this smallest element to every element that lies at the intersection of two lines. Leave the remaining elements of the matrix unchanged.

Now we get the following matrix

0	1	1	0
4	0	0	1
0	2	1	2
8	1	1	0

STEP 5:

Check if optimal assignment can be made in current feasible solution or not.

Repeat step 3 to get,

0	1	1	0
4	0	0	1
0	2	1	2
8	1	1	0

Iterations toward optimality

0	0	0	0
5	0	0	2
0	1	0	2
8	0	0	0

Third feasible solution

0	0	0	0
5	0	0	2
0	1	0	2
8	0	0	0

Check for optimality

Repeat step 3. As there is assignment in each row and each column, the optimal assignment can be made in current solution. Hence optimal assignment policy is

Hence optimal assignment policy is

Job J1 should be assigned to machine M1

Job J2 should be assigned to machine M2

Job J3 should be assigned to machine M3

Job J4 should be assigned to machine M4

And optimum cost = Rs (5+5+10+3)

= Rs 23

Assignment problem - maximization

		District			
		16	10	14	11
Salesman	14	14	11	15	15
	15	15	15	13	12
	13	13	12	14	15

Find the assignment of salesman to various districts which will yield maximum profit

Solution

As the given problem is of maximization type, it has to be reduced to minimization type. This is achieved by subtracting all the elements of the matrix from the highest element in it. The equivalent loss matrix is given below

0	6	2	5
2	5	1	1
1	1	3	4
3	4	2	1

Hungarian method can now be applied.

Initial basic feasible solution

0	6	2	5
1	4	0	0
0	0	2	3
2	3	1	0

Test for optimality

0	6	2	5
1	4	0	0
0	0	2	3
2	3	1	0

As there is one assignment in each row and in each column, optimal assignment can be made in the current feasible solution

- Salesman A should be assigned to district 1
- Salesman B should be assigned to district 3
- Salesman C should be assigned to district 2
- Salesman D should be assigned to district 4

Cost = 61

THE TRAVELLING SALESMAN PROBLEM

The condition for TSP is that no city is visited twice before the tour of all the cities is completed.

	A	B	C	D	E
A	0	2	5	7	1
B	6	0	3	8	2
C	8	7	0	4	7
D	12	4	6	0	5
E	1	3	2	8	0

As going from A->A,B->B etc is not allowed, assign a large penalty to these cells in the cost matrix

	A	B	C	D	E
A	<input type="checkbox"/>	1	4	6	0
B	4	<input type="checkbox"/>	1	6	0
C	4	3	<input type="checkbox"/>	0	3
D	8	0	2	<input type="checkbox"/>	1
E	0	2	1	7	<input type="checkbox"/>

	A	B	C	D	E
A	<input type="checkbox"/>	1	3	6	0
B	4	<input type="checkbox"/>	0	6	0
C	4	3	<input type="checkbox"/>	0	3
D	8	0	1	<input type="checkbox"/>	1
E	0	2	0	7	<input type="checkbox"/>

	A	B	C	D	E
A	<input type="checkbox"/>	1	3	6	
B	4	<input type="checkbox"/>	<input type="checkbox" value="0"/>	6	<input type="checkbox" value="0"/>
C	4	3	<input type="checkbox"/>	0	<input type="checkbox" value="3"/>
D	8		1	<input type="checkbox"/>	1
E	<input type="checkbox" value="0"/>	<input type="checkbox" value="2"/>	<input type="checkbox" value="0"/>	7	<input type="checkbox"/>

Which gives optimal for assignment problem but not for TSP because the path A->E, E-A, B->C->D->B does not satisfy the additional constraint of TSP

The next minimum element is 1, so we shall try to bring element 1 into the solution. We have three cases.

Case 1:

Make assignment in cell (A,B) instead of (A,E).

	A	B	C	D	E
A	∞	<input type="checkbox" value="1"/>	3	6	0
B	4	∞	<input type="checkbox" value="0"/>	6	\emptyset
C	4	3	∞	<input type="checkbox" value="0"/>	3
D	8	\emptyset	1	∞	<input type="checkbox" value="1"/>
E	<input type="checkbox" value="0"/>	2	\emptyset	7	∞

The resulting feasible solution is A->B, B->C, C->D, D->E, E->A and cost is 15
 Now make assignment in cell (D,C) instead of (D,B)

Case 2:

	A	B	C	D	E
A	∞	1	3	6	0
B	4	∞	\emptyset	6	\emptyset
C	4	3	∞	0	3
D	8	\emptyset	1	∞	1
E	0	2	\emptyset	7	∞

Since second row does not have any assignment. We can choose minimum cost in that row and if any assignment is there in that column, shift to next minimum cell.

	A	B	C	D	E
A	∞	1	3	6	0
B	4	∞	\emptyset	6	0
C	4	3	∞	0	3
D	8	\emptyset	1	∞	1
E	0	2	\emptyset	7	∞

Case 3:

	A	B	C	D	E
A	∞	1	3	6	\emptyset
B	4	∞	0	6	\emptyset
C	4	3	∞	0	3
D	8	\emptyset	1	∞	1
E	0	2	\emptyset	7	∞

Which is the same as case 1 . least cost route is given by a->b->c->d->e->a

UNIT-VQueuing theory

Queuing theory deals with problems which involve queuing (or waiting). Typical examples might be:

- banks/supermarkets - waiting for service
- computers - waiting for a response
- failure situations - waiting for a failure to occur e.g. in a piece of machinery
- public transport - waiting for a train or a bus

As we know queues are a common every-day experience. Queues form because resources are limited. In fact it makes *economic sense* to have queues. For example how many supermarket tills you would need to avoid queuing? How many buses or trains would be needed if queues were to be avoided/eliminated?

In designing queuing systems we need to aim for a balance between service to customers (short queues implying many servers) and economic considerations (not too many servers).

In essence all queuing systems can be broken down into individual sub-systems consisting of *entities* queuing for some *activity* (as shown below).

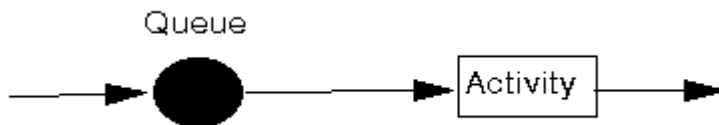

Typically we can talk of this individual sub-system as dealing with *customers* queuing for *service*. To analyse this sub-system we need information relating to:

- **arrival process:**
 - how customers arrive e.g. singly or in groups (batch or bulk arrivals)
 - how the arrivals are distributed in time (e.g. what is the probability distribution of time between successive arrivals (the *interarrival time distribution*))
 - whether there is a finite population of customers or (effectively) an infinite number

The simplest arrival process is one where we have completely regular arrivals (i.e. the same constant time interval between successive arrivals). A Poisson stream of arrivals corresponds to arrivals at random. In a Poisson stream successive customers arrive after intervals which independently are exponentially distributed. The Poisson stream is important as it is a convenient mathematical model of many real life queuing systems and is described by a single parameter - the average arrival rate. Other important arrival processes are scheduled arrivals; batch arrivals; and time dependent arrival rates (i.e. the arrival rate varies according to the time of day).

- **service mechanism:**
 - a description of the resources needed for service to begin
 - how long the service will take (the *service time distribution*)
 - the number of servers available

- whether the servers are in series (each server has a separate queue) or in parallel (one queue for all servers)
- whether preemption is allowed (a server can stop processing a customer to deal with another "emergency" customer)

Assuming that the service times for customers are independent and do not depend upon the arrival process is common. Another common assumption about service times is that they are exponentially distributed.

- **queue characteristics:**

- how, from the set of customers waiting for service, do we choose the one to be served next (e.g. FIFO (first-in first-out) - also known as FCFS (first-come first served); LIFO (last-in first-out); randomly) (this is often called the *queue discipline*)
- do we have:
 - balking (customers deciding not to join the queue if it is too long)
 - reneging (customers leave the queue if they have waited too long for service)
 - jockeying (customers switch between queues if they think they will get served faster by so doing)
 - a queue of finite capacity or (effectively) of infinite capacity

Changing the queue discipline (the rule by which we select the next customer to be served) can often reduce congestion. Often the queue discipline "choose the customer with the lowest service time" results in the smallest value for the time (on average) a customer spends queuing.

Note here that integral to queuing situations is the idea of uncertainty in, for example, interarrival times and service times. This means that probability and statistics are needed to analyse queuing situations.

In terms of the analysis of queuing situations the types of questions in which we are interested are typically concerned with measures of system performance and might include:

- How long does a customer expect to wait in the queue before they are served, and how long will they have to wait before the service is complete?
- What is the probability of a customer having to wait longer than a given time interval before they are served?
- What is the average length of the queue?
- What is the probability that the queue will exceed a certain length?
- What is the expected utilisation of the server and the expected time period during which he will be fully occupied (remember servers cost us money so we need to keep them busy). In fact if we can assign costs to factors such as customer waiting time and server idle time then we can investigate how to design a system at minimum total cost.

These are questions that need to be answered so that management can evaluate alternatives in an attempt to control/improve the situation. Some of the problems that are often investigated in practice are:

- Is it worthwhile to invest effort in reducing the service time?
- How many servers should be employed?
- Should priorities for certain types of customers be introduced?

- Is the waiting area for customers adequate?

In order to get answers to the above questions there are *two* basic approaches:

- analytic methods or queuing theory (formula based); and
- simulation (computer based).

The reason for there being two approaches (instead of just one) is that analytic methods are only available for relatively simple queuing systems. Complex queuing systems are almost always analysed using [simulation \(more technically known as discrete-event simulation\)](#).

The simple queuing systems that can be tackled via queuing theory essentially:

- consist of just a single queue; linked systems where customers pass from one queue to another cannot be tackled via queuing theory
- have distributions for the arrival and service processes that are well defined (e.g. standard statistical distributions such as Poisson or Normal); systems where these distributions are derived from observed data, or are time dependent, are difficult to analyse via queuing theory

The first queuing theory problem was considered by [Erlang](#) in 1908 who looked at how large a telephone exchange needed to be in order to keep to a reasonable value the number of telephone calls not connected because the exchange was busy (lost calls). Within ten years he had developed a (complex) formula to solve the problem.

Additional queuing theory information can be found [here](#) and [here](#)

Queuing notation and a simple example

It is common to use the symbols:

- λ to be the mean (or average) number of arrivals per time period, i.e. the mean arrival rate
- μ to be the mean (or average) number of customers served per time period, i.e. the mean service rate

There is a standard notation system to classify queuing systems as A/B/C/D/E, where:

- A represents the probability distribution for the arrival process
- B represents the probability distribution for the service process
- C represents the number of channels (servers)
- D represents the maximum number of customers allowed in the queuing system (either being served or waiting for service)
- E represents the maximum number of customers in total

Common options for A and B are:

- M for a Poisson arrival distribution (exponential interarrival distribution) or a exponential service time distribution

- D for a deterministic or constant value
- G for a general distribution (but with a known mean and variance)

If D and E are not specified then it is assumed that they are infinite.

For example the M/M/1 queueing system, the simplest queueing system, has a Poisson arrival distribution, an exponential service time distribution and a single channel (one server).

Note here that in using this notation it is always assumed that there is just a **single queue** (waiting line) and customers move from this single queue to the servers.

Simple M/M/1 example

Suppose we have a single server in a shop and customers arrive in the shop with a Poisson arrival distribution at a mean rate of $\lambda=0.5$ customers per minute, i.e. on average one customer appears every $1/\lambda = 1/0.5 = 2$ minutes. This implies that the interarrival times have an exponential distribution with an average interarrival time of 2 minutes. The server has an exponential service time distribution with a mean service rate of 4 customers per minute, i.e. the service rate $\mu=4$ customers per minute. As we have a Poisson arrival rate/exponential service time/single server we have a M/M/1 queue in terms of the standard notation.

We can analyse this queueing situation using the [package](#). The input is shown below:

The screenshot shows a software interface titled "Problem Specification". It contains the following elements:

- Problem Title:** A text box containing "Queuing Problem".
- Time Unit:** A text box containing "minute".
- Entry Format:** A section with two radio buttons:
 - Simple M/M System
 - General Queuing System

Data Description	ENTRY
Number of servers	1
Service rate (per server per minute)	4
Customer arrival rate (per minute)	0.5
Queue capacity (maximum waiting space)	M
Customer population	M

with the output being:

11-14-2000	Performance Measure	Result
1	System: M/M/1	From Formula
2	Customer arrival rate (λ) per minute =	0.5000
3	Service rate per server (μ) per minute =	4.0000
4	Overall system effective arrival rate per minute =	0.5000
5	Overall system effective service rate per minute =	0.5000
6	Overall system utilization =	12.5000 %
7	Average number of customers in the system (L) =	0.1429
8	Average number of customers in the queue (Lq) =	0.0179
9	Average number of customers in the queue for a busy system (Lb) =	0.1429
10	Average time customer spends in the system (W) =	0.2857 minutes
11	Average time customer spends in the queue (Wq) =	0.0357 minutes
12	Average time customer spends in the queue for a busy system (Wb) =	0.2857 minutes
13	The probability that all servers are idle (Po) =	87.5000 %
14	The probability an arriving customer waits (Pw or Pb) =	12.5000 %

The first line of the output says that the results are from a formula. For this very simple queueing system there are exact formulae that give the statistics above under the assumption that the system has reached a **steady state - that is that the system has been running long enough so as to settle down into some kind of equilibrium position.**

Naturally real-life systems hardly ever reach a steady state. Simply put life is not like that. However despite this simple queueing formulae can give us some insight into how a system might behave very quickly. The [package](#) took a fraction of a second to produce the output seen above.

One factor that is of note is *traffic intensity* = (arrival rate)/(departure rate) where arrival rate = number of arrivals per unit time and departure rate = number of departures per unit time. Traffic intensity is a measure of the congestion of the system. If it is near to zero there is very little queuing and in general as the traffic intensity increases (to near 1 or even greater than 1) the amount of queuing increases. For the system we have considered above the arrival rate is 0.5 and the departure rate is 4 so the traffic intensity is $0.5/4 = 0.125$

Faster servers or more servers?

Consider the situation we had above - which would you prefer:

- one server working twice as fast; or
- two servers each working at the original rate?

The simple answer is that we can analyse this using the package. For the first situation one server working twice as fast corresponds to a service rate $\mu=8$ customers per minute. The output for this situation is shown below.

11-15-2000	Performance Measure	Result
1	System: M/M/1	From Formula
2	Customer arrival rate (λ) per minute =	0.5000
3	Service rate per server (μ) per minute =	8.0000
4	Overall system effective arrival rate per minute =	0.5000
5	Overall system effective service rate per minute =	0.5000
6	Overall system utilization =	6.2500 %
7	Average number of customers in the system (L) =	0.0667
8	Average number of customers in the queue (Lq) =	0.0042
9	Average number of customers in the queue for a busy system (Lb) =	0.0667
10	Average time customer spends in the system (W) =	0.1333 minutes
11	Average time customer spends in the queue (Wq) =	0.0083 minutes
12	Average time customer spends in the queue for a busy system (Wb) =	0.1333 minutes
13	The probability that all servers are idle (Po) =	93.7500 %
14	The probability an arriving customer waits (Pw or Pb) =	6.2500 %

For two servers working at the original rate the output is as below. Note here that this situation is a M/M/2 queueing system. Note too that the package assumes that these two servers are fed from a single queue (rather than each having their own individual queue).

Data Description	ENTRY
Number of servers	2
Service rate (per server per minute)	4
Customer arrival rate (per minute)	0.5
Queue capacity (maximum waiting space)	M
Customer population	M

11-15-2000	Performance Measure	Result
1	System: M/M/2	From Formula
2	Customer arrival rate (λ) per minute =	0.5000
3	Service rate per server (μ) per minute =	4.0000
4	Overall system effective arrival rate per minute =	0.5000
5	Overall system effective service rate per minute =	0.5000
6	Overall system utilization =	6.2500 %
7	Average number of customers in the system (L) =	0.1255
8	Average number of customers in the queue (Lq) =	0.0005
9	Average number of customers in the queue for a busy system (Lb) =	0.0667
10	Average time customer spends in the system (W) =	0.2510 minutes
11	Average time customer spends in the queue (Wq) =	0.0010 minutes
12	Average time customer spends in the queue for a busy system (Wb) =	0.1333 minutes
13	The probability that all servers are idle (Po) =	88.2353 %
14	The probability an arriving customer waits (Pw or Pb) =	0.7353 %

Compare the two outputs above - which option do you prefer?

Of the figures in the outputs above some are identical. Extracting key figures which are different we have:

One server twice as fast Two servers, original rate

Average time in the system (waiting and being served)	0.1333	0.2510
Average time in the queue	0.0083	0.0010
Probability of having to wait for service	6.25%	0.7353%

It can be seen that with one server working twice as fast customers spend less time in the system on average, but have to wait longer for service and also have a higher probability of having to wait for service.

Extending the example: M/M/1 and M/M/2 with costs

Below we have extended the example we had before where now we have multiplied the customer arrival rate by a factor of six (i.e. customers arrive 6 times as fast as before). We have also entered a queue capacity (waiting space) of 2 - i.e. if all servers are occupied and 2 customers are waiting when a new customer appears then they go away - this is known as **balking**.

We have also added cost information relating to the server and customers:

- each minute a server is idle costs us £0.5
- each minute a customer waits for a server costs us £1
- each customer who is balked (goes away without being served) costs us £5

The package input is shown below:

Data Description	ENTRY
Number of servers	1
Service rate (per server per minute)	4
Customer arrival rate (per minute)	3
Queue capacity (maximum waiting space)	2
Customer population	M
Busy server cost per minute	
Idle server cost per minute	0.5
Customer waiting cost per minute	1
Customer being served cost per minute	
Cost of customer being balked	5
Unit queue capacity cost	

with the output being:

11-14-2000	Performance Measure	Result
1	System: M/M/1/3	From Formula
2	Customer arrival rate (λ) per minute =	3.0000
3	Service rate per server (μ) per minute =	4.0000
4	Overall system effective arrival rate per minute =	2.5371
5	Overall system effective service rate per minute =	2.5371
6	Overall system utilization =	63.4286 %
7	Average number of customers in the system (L) =	1.1486
8	Average number of customers in the queue (Lq) =	0.5143
9	Average number of customers in the queue for a busy system (Lb) =	0.8108
10	Average time customer spends in the system (W) =	0.4527 minutes
11	Average time customer spends in the queue (Wq) =	0.2027 minutes
12	Average time customer spends in the queue for a busy system (Wb) =	0.3196 minutes
13	The probability that all servers are idle (Po) =	36.5714 %
14	The probability an arriving customer waits (Pw or Pb) =	63.4286 %
15	Average number of customers being balked per minute =	0.4629
16	Total cost of busy server per minute =	\$0
17	Total cost of idle server per minute =	\$0.1829
18	Total cost of customer waiting per minute =	\$0.5143
19	Total cost of customer being served per minute =	\$0
20	Total cost of customer being balked per minute =	\$2.3143
21	Total queue space cost per minute =	\$0
22	Total system cost per minute =	\$3.0114

Note, as the above output indicates, that this is an M/M/1/3 system since we have 1 server and the maximum number of customers that can be in the system (either being served or waiting) is 3 (one being served, two waiting).

The key here is that as we have entered cost data we have a figure for the total cost of operating this system, 3.0114 per minute (in the steady state).

Suppose now we were to have two servers instead of one - would the cost be less or more? The simple answer is that the package can tell us, as below. Note that this is an M/M/2/4 queueing system as we have two servers and a total number of customers in the system of 4 (2 being served, 2 waiting in the queue for service). Note too that the package assumes that these two servers are fed from a single queue (rather than each having their own individual queue).

Data Description	ENTRY
Number of servers	2
Service rate (per server per minute)	4
Customer arrival rate (per minute)	3
Queue capacity (maximum waiting space)	2
Customer population	M
Busy server cost per minute	
Idle server cost per minute	0.5
Customer waiting cost per minute	1
Customer being served cost per minute	
Cost of customer being balked	5
Unit queue capacity cost	

11-14-2000	Performance Measure	Result
1	System: M/M/2/4	From Formula
2	Customer arrival rate (λ) per minute =	3.0000
3	Service rate per server (μ) per minute =	4.0000
4	Overall system effective arrival rate per minute =	2.9455
5	Overall system effective service rate per minute =	2.9455
6	Overall system utilization =	36.8185 %
7	Average number of customers in the system (L) =	0.8212
8	Average number of customers in the queue (Lq) =	0.0848
9	Average number of customers in the queue for a busy system (Lb) =	0.4330
10	Average time customer spends in the system (W) =	0.2788 minutes
11	Average time customer spends in the queue (Wq) =	0.0288 minutes
12	Average time customer spends in the queue for a busy system (Wb) =	0.1470 minutes
13	The probability that all servers are idle (Po) =	45.9502 %
14	The probability an arriving customer waits (Pw or Pb) =	19.5872 %
15	Average number of customers being balked per minute =	0.0545
16	Total cost of busy server per minute =	\$0
17	Total cost of idle server per minute =	\$0.6318
18	Total cost of customer waiting per minute =	\$0.0848
19	Total cost of customer being served per minute =	\$0
20	Total cost of customer being balked per minute =	\$0.2726
21	Total queue space cost per minute =	\$0
22	Total system cost per minute =	\$0.9892

So we can see that there is a considerable cost saving per minute in having two servers instead of one.

In fact the package can automatically perform an analysis for us of how total cost varies with the number of servers. This can be seen below.

Capacity Analysis

Number of Servers

Start from:

End at:

Step:

Specify either approximation or simulation for solution if no close form formula is available.

Solution Method

Approximation by G/G/s

Monte Carlo Simulation

Queue Capacity

Start from:

End at:

Step:

OK

Cancel

Help

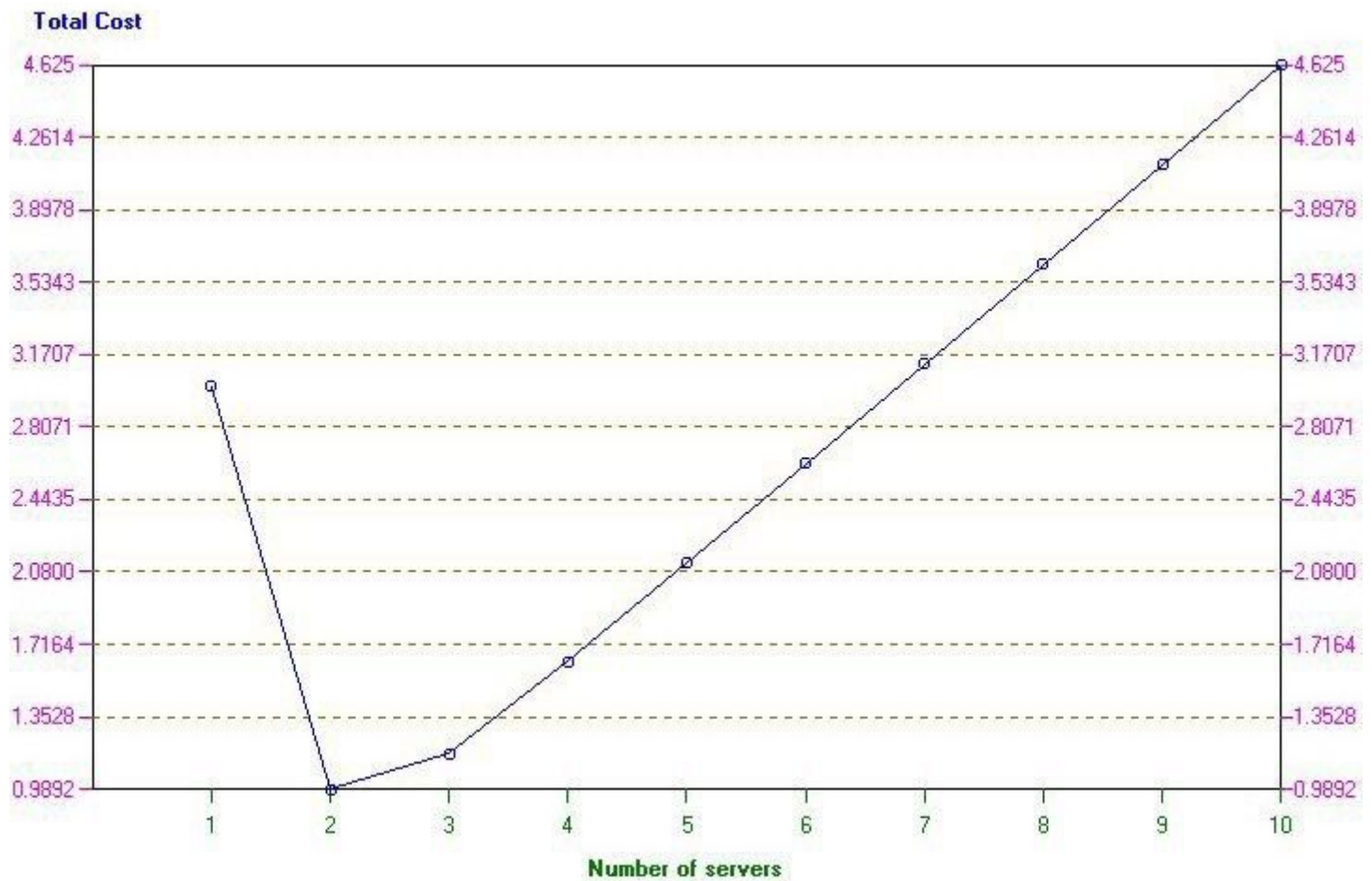

General queueing

The screen below shows the possible input parameters to the package in the case of a general queueing model (i.e. not a M/M/r system).

Data Description	ENTRY
Number of servers	
Service time distribution (in minute)	Exponential
Location parameter (a)	
Scale parameter (b>0) (b=mean if a=0)	
(Not used)	
Service pressure coefficient	
Interarrival time distribution (in minute)	Exponential
Location parameter (a)	
Scale parameter (b>0) (b=mean if a=0)	
(Not used)	
Arrival discourage coefficient	
Batch (bulk) size distribution	Constant
Constant value	1
(Not used)	
(Not used)	
Queue capacity (maximum waiting space)	M
Customer population	M
Busy server cost per minute	
Idle server cost per minute	
Customer waiting cost per minute	
Customer being served cost per minute	
Cost of customer being balked	
Unit queue capacity cost	

Here we have a number of possible choices for the service time distribution and the interarrival time distribution. In fact the package recognises some 15 different distributions! Other items mentioned above are:

- service pressure coefficient - indicates how servers speed up service when the system is busy, i.e. when all servers are busy the service rate is increased. If this coefficient is s and we have r servers each with service rate μ then the service rate changes from μ to $(n/r)^s \mu$ when there are n customers in the system and $n \geq r$.
- arrival discourage coefficient - indicates how customer arrivals are discouraged when the system is busy, i.e. when all servers are busy the arrival rate is decreased. If this coefficient is s and we have r servers with the arrival rate being λ then the arrival rate changes from λ to $(r/(n+1))^s \lambda$ when there are n customers in the system and $n \geq r$.
- batch (bulk) size distribution - customers can arrive together (in batches, also known as in bulk) and this indicates the distribution of size of such batches.

As an indication of the analysis that can be done an example problem is shown below:

Data Description	ENTRY
Number of servers	1
Service time distribution (in hour)	Normal
Mean (μ)	.7
Standard deviation ($\sigma > 0$)	.2
(Not used)	
Service pressure coefficient	1.5
Interarrival time distribution (in hour)	Exponential
Location parameter (a)	
Scale parameter ($b > 0$) ($b = \text{mean}$ if $a = 0$)	.5
(Not used)	
Arrival discourage coefficient	1.7
Batch (bulk) size distribution	Normal
Mean (μ)	3
Standard deviation ($\sigma > 0$)	0.5
(Not used)	
Queue capacity (maximum waiting space)	4
Customer population	
Busy server cost per hour	10
Idle server cost per hour	100
Customer waiting cost per hour	500
Customer being served cost per hour	5
Cost of customer being balked	600
Unit queue capacity cost	

Solving the problem we get:

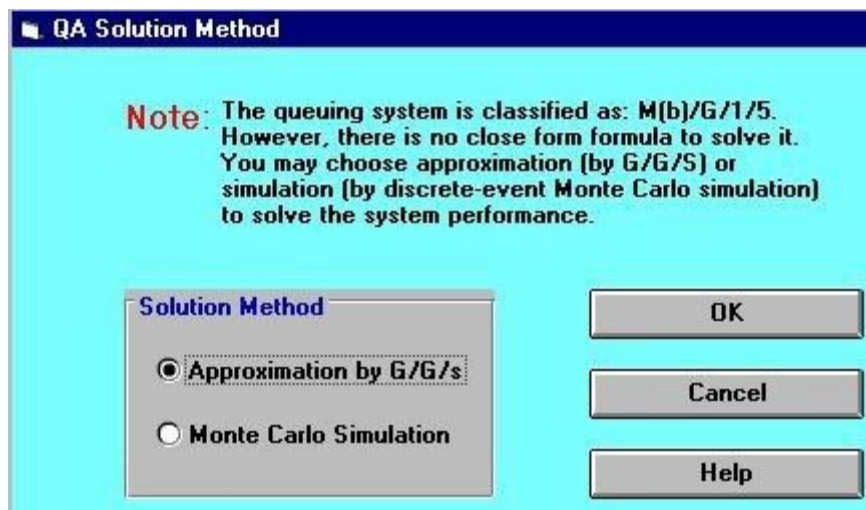

This screen indicates that no formulae exist to evaluate the situation we have set up. We can try to evaluate this situation using an approximation formula, or by Monte Carlo Simulation. If we choose to adopt the approximation approach we get:

11-14-2000	Performance Measure	Result
1	System: M(b)/G/1/5	From Approximation
2	Customer arrival rate (λ) per hour =	2.0000
3	Service rate per server (μ) per hour =	1.4286
4	Overall system effective arrival rate per hour =	2.0000
5	Overall system effective service rate per hour =	2.0000
6	Overall system utilization =	420.0000 %
7	Average number of customers in the system (L) =	1.2187
8	Average number of customers in the queue (Lq) =	-2.9813
9	Average number of customers in the queue for a busy system (Lb) =	-0.7098
10	Average time customer spends in the system (W) =	0.6094 hours
11	Average time customer spends in the queue (Wq) =	-1.4906 hours
12	Average time customer spends in the queue for a busy system (Wb) =	-0.3549 hours
13	The probability that all servers are idle (Po) =	-320.0000 %
14	The probability an arriving customer waits (Pw or Pb) =	420.0000 %
15	Average number of customers being balked per hour =	0
16	Total cost of busy server per hour =	\$42.0000
17	Total cost of idle server per hour =	\$-320.0000
18	Total cost of customer waiting per hour =	\$-1490.6250
19	Total cost of customer being served per hour =	\$21.0000
20	Total cost of customer being balked per hour =	\$0
21	Total queue space cost per hour =	\$0
22	Total system cost per hour =	\$-1747.6250

The difficulty is that these approximation results are plainly nonsense (i.e. not a good approximation). For example the average number of customers in the queue is -2.9813, the probability that all servers are idle is -320%, etc. Whilst for this particular case it is obvious that approximation (or perhaps the package) is not working, for other problems it may not be readily apparent that approximation does not work.

If we adopt the Monte Carlo Simulation approach then we have the screen below.

Simulation Specification

Random Seed <input checked="" type="radio"/> Use default random seed <input type="radio"/> Enter a seed number <input type="radio"/> Use system clock	Queue Discipline <input checked="" type="radio"/> FIFO <input type="radio"/> LIFO <input type="radio"/> Random
Random seed number:	<input style="width: 100%;" type="text" value="27437"/>
Simulation time:	<input style="width: 100%;" type="text" value="1000"/> hours
Start collection time:	<input style="width: 100%;" type="text" value="0"/> hours
Queue capacity:	<input style="width: 100%;" type="text" value="4"/>
Max. number of data collections:	<input style="width: 100%;" type="text" value="M"/>

What will happen here is that the computer will construct a model of the system we have specified and internally generate customer arrivals, service times, etc and collect statistics on how the system performs. As specified above it will do this for 1000 time units (hours in this case). The phrase "Monte Carlo" derives from the well-known gambling city on the Mediterranean in Monaco. Just as in roulette we get random numbers produced by a roulette wheel when it is spun, so in Monte Carlo simulation we make use of random numbers generated by a computer.

The results are shown below:

11-14-2000	Performance Measure	Result
1	System: M(b)/G/1/5	From Simulation
2	Customer arrival rate (λ) per hour =	2.0000
3	Service rate per server (μ) per hour =	1.4286
4	Overall system effective arrival rate per hour =	1.4129
5	Overall system effective service rate per hour =	1.4079
6	Overall system utilization =	99.7974 %
7	Average number of customers in the system (L) =	4.2882
8	Average number of customers in the queue (Lq) =	3.2902
9	Average number of customers in the queue for a busy system (Lb) =	3.2969
10	Average time customer spends in the system (W) =	3.0418 hours
11	Average time customer spends in the queue (Wq) =	2.3330 hours
12	Average time customer spends in the queue for a busy system (Wb) =	2.3377 hours
13	The probability that all servers are idle (Po) =	0.2026 %
14	The probability an arriving customer waits (Pw or Pb) =	99.7974 %
15	Average number of customers being balked per hour =	4.6478
16	Total cost of busy server per hour =	\$9.9797
17	Total cost of idle server per hour =	\$0.2025
18	Total cost of customer waiting per hour =	\$1648.1810
19	Total cost of customer being served per hour =	\$5.0071
20	Total cost of customer being balked per hour =	\$2788.6530
21	Total queue space cost per hour =	\$0
22	Total system cost per hour =	\$4452.0230
23	Simulation time in hour =	1000.0000
24	Starting data collection time in hour =	0
25	Number of observations collected =	1408
26	Maximum number of customers in the queue =	4
27	Total simulation CPU time in second =	2.4170

These results seem much more reasonable than the results obtained the approximation.

However one factor to take into consideration is the simulation time we specified - here 1000 hours. In order to collect more accurate information on the behaviour of the system we might wish to simulate for longer. The results for simulating both 10 and 100 times as long are shown below.

11-14-2000	Performance Measure	Result
1	System: M(b)/G/1/5	From Simulation
2	Customer arrival rate (λ) per hour =	2.0000
3	Service rate per server (μ) per hour =	1.4286
4	Overall system effective arrival rate per hour =	1.4272
5	Overall system effective service rate per hour =	1.4268
6	Overall system utilization =	99.8225 %
7	Average number of customers in the system (L) =	4.2827
8	Average number of customers in the queue (Lq) =	3.2844
9	Average number of customers in the queue for a busy system (Lb) =	3.2903
10	Average time customer spends in the system (W) =	3.0010 hours
11	Average time customer spends in the queue (Wq) =	2.3013 hours
12	Average time customer spends in the queue for a busy system (Wb) =	2.3054 hours
13	The probability that all servers are idle (Po) =	0.1775 %
14	The probability an arriving customer waits (Pw or Pb) =	99.8225 %
15	Average number of customers being balked per hour =	4.6027
16	Total cost of busy server per hour =	\$9.9823
17	Total cost of idle server per hour =	\$0.1766
18	Total cost of customer waiting per hour =	\$1642.2850
19	Total cost of customer being served per hour =	\$4.9925
20	Total cost of customer being balked per hour =	\$2761.6240
21	Total queue space cost per hour =	\$0
22	Total system cost per hour =	\$4419.0610
23	Simulation time in hour =	10000.0000
24	Starting data collection time in hour =	0
25	Number of observations collected =	14269
26	Maximum number of customers in the queue =	4
27	Total simulation CPU time in second =	23.6630

11-14-2000	Performance Measure	Result
1	System: M(b)/G/1/5	From Simulation
2	Customer arrival rate (λ) per hour =	2.0000
3	Service rate per server (μ) per hour =	1.4286
4	Overall system effective arrival rate per hour =	1.4266
5	Overall system effective service rate per hour =	1.4265
6	Overall system utilization =	99.7353 %
7	Average number of customers in the system (L) =	4.2723
8	Average number of customers in the queue (Lq) =	3.2751
9	Average number of customers in the queue for a busy system (Lb) =	3.2838
10	Average time customer spends in the system (W) =	2.9950 hours
11	Average time customer spends in the queue (Wq) =	2.2958 hours
12	Average time customer spends in the queue for a busy system (Wb) =	2.3019 hours
13	The probability that all servers are idle (Po) =	0.2647 %
14	The probability an arriving customer waits (Pw or Pb) =	99.7353 %
15	Average number of customers being balked per hour =	4.5840
16	Total cost of busy server per hour =	\$9.9718
17	Total cost of idle server per hour =	\$0.2816
18	Total cost of customer waiting per hour =	\$1637.5800
19	Total cost of customer being served per hour =	\$4.9870
20	Total cost of customer being balked per hour =	\$2750.4130
21	Total queue space cost per hour =	\$0
22	Total system cost per hour =	\$4403.2330
23	Simulation time in hour =	100000.0000
24	Starting data collection time in hour =	0
25	Number of observations collected =	142654
26	Maximum number of customers in the queue =	4
27	Total simulation CPU time in second =	245.9250

Clearly the longer we simulate, the more confidence we may have in the statistics/probabilities obtained.

As before we can investigate how the system might behave with more servers. Simulating for 1000 hours (to reduce the overall elapsed time required) and looking at just the total system cost per hour (item 22 in the above outputs) we have the following:

Number of servers	Total system cost
1	4452
2	3314
3	2221
4	1614
5	1257
6	992
7	832
8	754
9	718
10	772
11	833
12	902

Hence here the number of servers associated with the minimum total system cost is 9

UNIT- VI

PERT and CPM

PERT – Program Evaluation and Review Technique

CPM – Critical Path Method

Activity – It is a physically identifiable part of a project which consumes time and resources.

Event – the beginning and end points of an activity are called events or nodes. Event is a point in time and does not consume any resources. It is generally represented by a numbered circle.

Example:

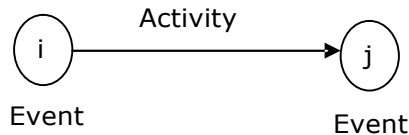

Path – An unbroken chain of activity arrows connecting the initial event to some other event is called a path.

Network - It is the graphical representation of logically and sequentially connected arrows and nodes representing activities and events of a project.

Network construction – Firstly the project is split into activities. While constructing the network , in order to ensure that the activities follow a logical sequence. The following questions are checked.

Example

An assembly is to be made from two parts X and Y. both parts must be turned on a lathe and Y must be polished, X need not be polished. The sequences of activity together with their predecessors are given below.

Activity	Description	Predecessor
A	Open work order	-
B	Get material for X	A
C	Get material for Y	A
D	Turn X on lathe	B
E	Turn Y on lathe	B,C
F	Polish Y	E
G	Assemble X and Y	D,F
H	Pack	G

Draw a network diagram

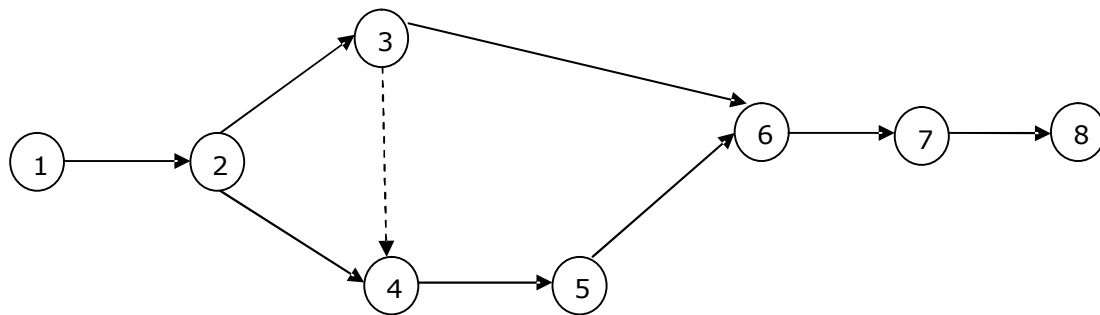

Consider the following notations for calculating various times of events and activities.

- E_i = Earliest occurrence time of event i
- L_i = Latest occurrence time of event i
- ES_{ij} = Earliest start time for activity (i,j)
- LS_{ij} = Latest start time for activity (i,j)
- EF_{ij} = Earliest finish time for activity (i,j)
- LF_{ij} = Latest finish time for activity (i,j)
- T_{ij} = duration of activity (i,j)

Total float

The difference between the maximum time available to perform the activity and activity duration time.

Free float

The difference between the earliest start time for the successor activity and earliest completion time for activity under consideration.

Independent float

The difference between the predecessor event occurring at its latest possible time and the successor event at its earliest possible time.

1. Consider the Network shown below. The three time estimates for activities are along the arrow. Determine the critical path. What is the probability that the project will be completed in 20 days?

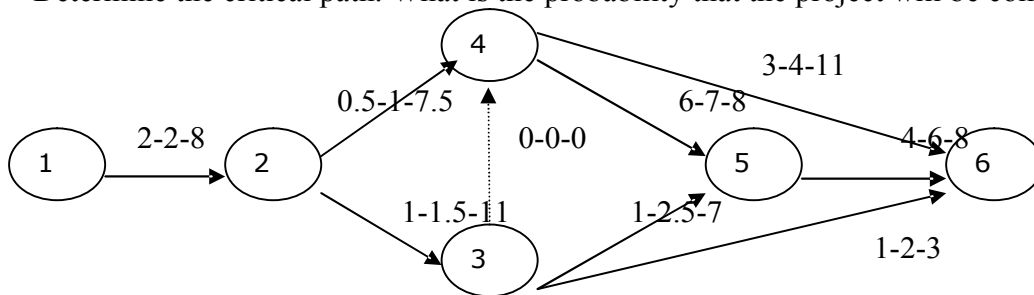

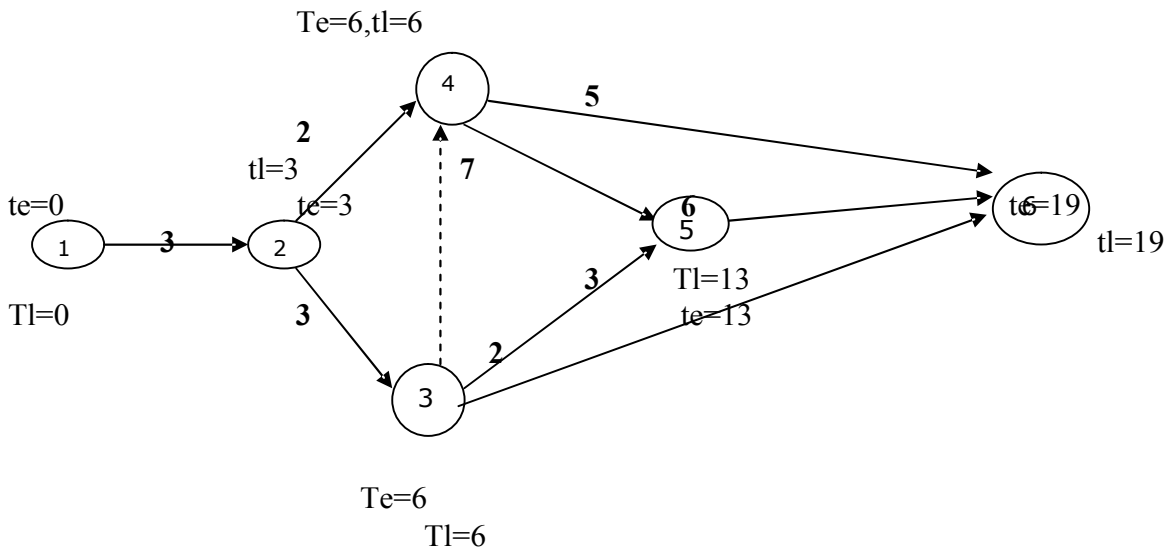

$$V = [(tp - to) / 6]^2$$

$$\Sigma = 2.08$$

$$z = Ts - Te / \Sigma$$

$$Z = 0.48$$

From Std Dev. Probability = 68.44%

Crashing the network

Project crashing

Crashing is employed to reduce the project completion time by spending extra resources. Since for technical reasons, time may not be reduced indefinitely, we call this limit crash point.

Cost slope = (crash cost - normal cost) / (normal time - crash time)

Example:

The following table gives data on normal time and cost and crash time and cost for a project.

Activity	Normal		Crash	
	Time(weeks)	Cost	Time(weeks)	Cost
1-2	3	300	2	400
2-3	3	30	3	30
2-4	7	420	5	580
2-5	9	720	7	810
3-5	5	250	4	300
4-5	0	0	0	0
5-6	6	320	4	410
6-7	4	400	3	470
6-8	13	780	10	900
7-8	10	1000	9	1200

Indirect cost is Rs 50 per week. Crash the relevant activities systematically and determine the optimal project completion time and cost.

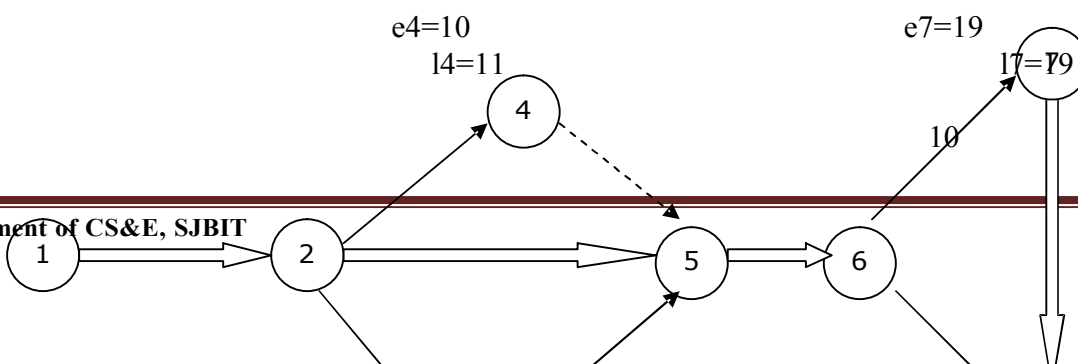
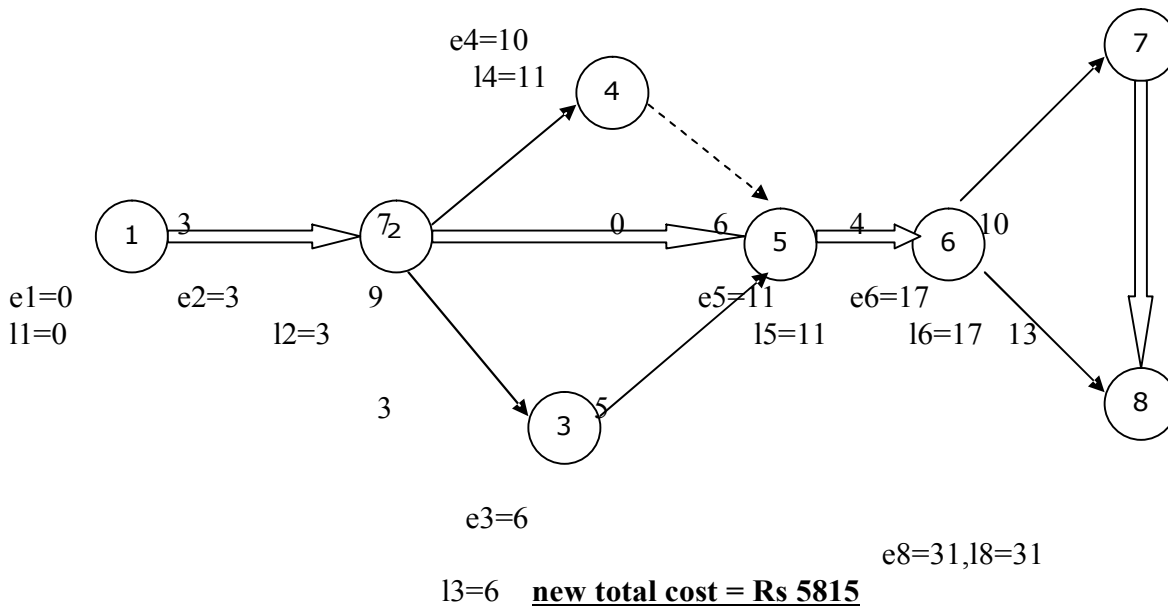
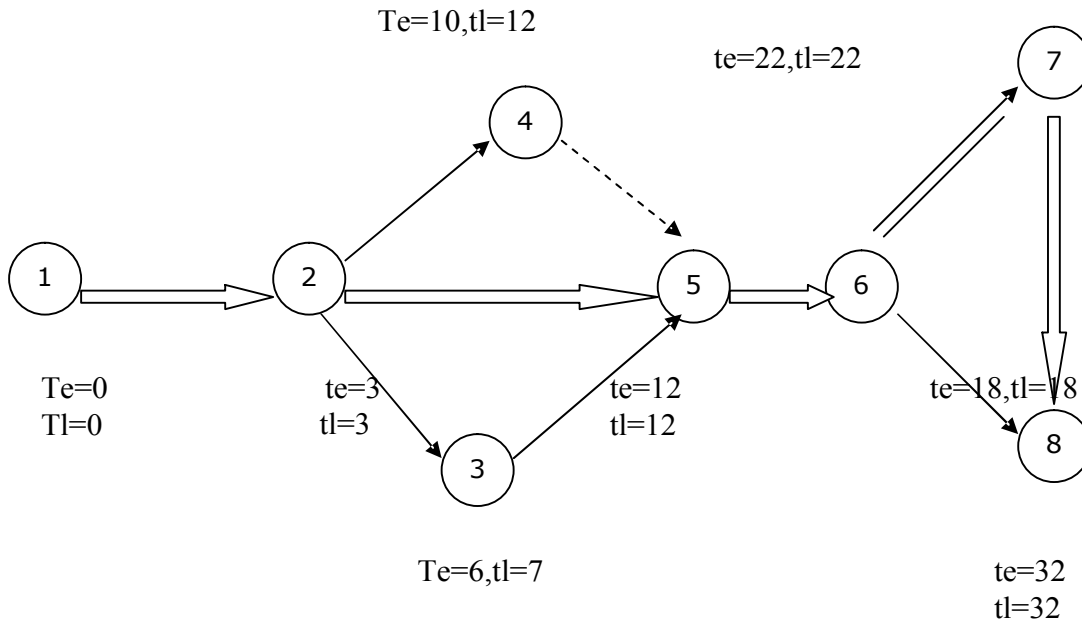

E1=10 e2=3 3 5 e5=11 e6=15 13
 L1=10
 12=3 15=11 16=15

E3=6,13=6

e8=29
 L8=29

New total cost = Rs 5805

Resource leveling

Activity	Normal time	Man power required
0-1	2	4
1-2	3	3
1-3	4	3
2-4	2	5
3-5	4	3
3-6	3	4
4-7	6	3
5-7	6	6
6-8	5	2
7-9	4	2
8-9	4	9

- a) Draw the network diagram and find the critical path.
- b) Rearrange the activities suitably for reducing the existing total manpower requirement.

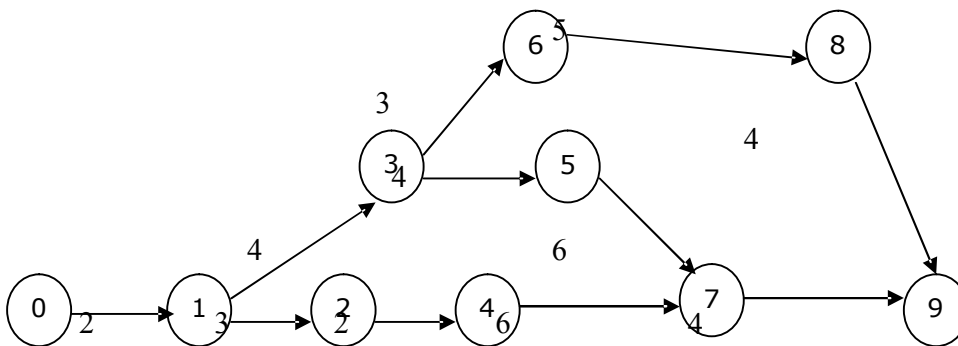

	3(3)	2(5)		6(3)															
2(4)	4(3)		4(3)					6(6)										4(2)	
				3(4)				5(2)										4(9)	
					3(4)				5(2)										4(9)

1	2	3	4	5	6	7	8	9	10	11	12	13	14	15	16	17	18	19	20
4	4	6	6	6	8	12	10	10	8	11	11	11	8	15	15	11	11	2	2
4	4	6	6	6	8	8	10	10	10	9	11	11	8	8	8	11	11	11	11

Thus the man power is reduced to 11 people.

Deterministic Inventory Controls Model

An idle resource of any kind provides such as a resource has economic value. Such resources may be classified into three categories

- (i) Physical resources such as raw materials, semi-finished goods, finished goods, spare parts, etc.
- (ii) Human resources such as unused labor (man power).
- (iii) Financial resource such as working capital, etc.

Economic order quantity (EOQ) for finding the optimum order quantity in order to balance costs to balance costs of holding too much stock against that of ordering in small quantities too frequently.

Model: 1 (a) (Demand Rate Uniform production rate Infinite.)

R - Demand Rate

C_3 – Setup cost per production (C_p)

Lead time is zero.

C_1 – cost of holding one unit. (C_h)

Optimum interval,

$$T_0 = \text{Sqrt}(2C_3/C_1R)$$

Optimum Quantity,

$$Q_0 = R t_0 = \text{Sqrt}(2C_3 R / C_1)$$

Minimum Average cost

$$C_0 = \text{Sqrt}(2C_1 \cdot C_3 R)$$

Example:

A particular item has a demand of 9000 units/year. The cost of one procurement is Rs.100 and the holding cost per unit is Rs.2.240 per year. The replacement is instantaneous & no shortages are allowed.

Determine,

- (i) Economic lot size,
- (ii) Number of orders per year,
- (iii) Time between orders,
- (iv) The total cost per year if the cost of one unit is Re1

Solution

$R = 9,000$ units/year

$C_3 = \text{Rs. } 100$ /procurement,

$C_1 = \text{Rs } 2.40$ /unit/year

- (i) $q_0 = \text{Sqrt}(2C_3 R / C_1) = \text{Sqrt}(2 * 100 * 9000 / 2.40) = 866$ units/procurement
- (ii) $N_0 = \text{Sqrt}(C_1 R / 2C_3) = \text{Sqrt}(2.40 * 9000 / (2 * 100)) = 10.4$ orders/year
- (iii) $T_0 = 1 / N_0 = 1 / 10.4 = .0962$ years between procurement.
- (iv) $C_0 = 9000 + \text{Sqrt}(2C_1 C_3 R) = 9000 + \text{Sqrt}(2 * 2.40 * 100 * 9000) = \text{Rs } 11080$ /year

Model: 2 (a) (Demand Rate Uniform, Production Rate, Infinite, shortages Allowed)

This model is just the extension of model 1(a) allowing shortage .

C_2 – Shortage cost per item per unit time. (C_s)

Example

Solve the previous problem in addition to the data given that the problem the cost of shortage is also given as Rs.5 per unit per year.

Solution

$R=9000$

$C_3 = \text{Rs } 100 / \text{procurement}$

$C_1 = \text{Rs } 2.40 / \text{unit/procurement}$

$C_2 = \text{Rs } 5 / \text{unit/year}$

(i) From Equation $q_0 = \sqrt{(C_1 + C_2) / C_2} * \sqrt{2C_3R / C_1} = \sqrt{(2.40+5)/5} * \sqrt{2*100*9000/2.4}$

$$= 1053 \text{ units/run}$$

(ii) $C_0(I_m, q) = 9000 * 1 + \sqrt{C_2(C_2 + C_1)} * \sqrt{2C_1C_3R} = 10710 / \text{year}$

(iii) Number of orders/year

$$N_0 = 9000 / 1053 = 8.55$$

(iv) Time between orders,

$$t_0 = 1 / N_0 = 1 / 8.55 = 0.117 \text{ year}$$

Example

The demand for a commodity is 100 units per day. Every time an order is placed, a fixed cost Rs. 400 is incurred. Holding cost is Rs 0.08 per unit per day. If the lead time is 13 days, determine the economic lot size & the reorder point

Solution

$$Q_0 = \sqrt{2C_3R / C_3} = \sqrt{2*4*100/0.08} = 1000 \text{ units.}$$

Length of the cycle $t_0 = 1000/100 = 10$ days.

As the lead time is 13 days & the cycle length is 10 days, recording should occur when the level of inventory is sufficient to satisfy the demand for $13-10 = 3$ days

□ Reorder point $= 100 * 3 = 300$ units.

It may be noted that the 'effective' lead time is taken equal to 3 days rather than 13 days. It is because the lead time is longer than t_0 .

Model 1(b) (Demand Rate Non-uniform, production Rate Infinite)

In this method all assumptions are same as in model 1(a) with the exception that instead of uniform demand rate R , we are given some total amount D , to be satisfied during some long time period T . Thus, demand rates are different in different production runs

$$\text{Optimal Lot size } q_0 = \sqrt{2C_3(D/T)/C_1}$$

$$\text{And minimum total cost, } C_0(q) = \sqrt{2C_1C_3(D/T)}$$

Here, it can be noted that the uniform demand rate R in model 1(a) is replaced by average demand rate D/T .

Example

A manufacturing company purchases 9000 parts of a machine for its actual requirements, ordering one month's requirement at a time. Each part costs Rs.20. the ordering cost per order is Rs.15 and the are 15% of the average inventory per year. You have been asked to suggest a more economical purchasing policy for the company. What advice would you offer & how much would it save the company per year?

Solution

$$D=9000$$

$$C_3=15$$

$$C_0=15$$

$$C_1=15\% \text{ of the investment in inventories}$$

$$=20 \text{ of } 0.15 = \text{Rs.}30 \text{ per year}$$

$$\text{Optimal Size}=\text{Sqrt}(2C_3(D/T)/C_1)=300 \text{ units.}$$

$$\text{Total Cost}=\text{Sqrt}(2C_1C_3(D/T))=\text{Rs}900$$

Model 1(c) Demand rate uniform, production that finite

R = number of items required per unit time,

K = number of items produced per unit time,

$$\text{Optimum Lot Size } q_0 = \sqrt{\frac{2C_3}{c_1} \cdot \frac{RK}{K_1 - R}}$$

$$\text{Optimum average cost} = \sqrt{2C_1C_2R \cdot \frac{K - R}{K}}$$

$$\text{Time interval, } t_0 = \frac{q_0}{R} = \sqrt{\frac{K}{K - R} \cdot \frac{2C_3}{C_1R}}$$

$$\text{max. inventory } I_{\text{mo}} = \frac{K - R}{K} \cdot q_0$$

Example:

A company has a demand of 12,000 units/year for an item and it can produce 2,000 such items per month. The cost of one setup is Rs. 400 and the holding cost/unit/month is Re. 0.15. find the optimum lot size and the total cost per year, assuming the cost of 1 unit as Rs. 4. also, find the maximum inventory, manufacturing time and total time.

Solution:

$$R = 12,000 \text{ units/year}$$

$$K = 2,000 * 12 = 24,000 \text{ units/year}$$

$$C_3 = \text{Rs. } 400$$

$$C_1 = \text{Rs. } 0.15 * 12 = \text{Rs. } 1.80/\text{unit/year}$$

$$\text{Optimum Lot Size } q_0 = \sqrt{\frac{2C_3}{c_1} \cdot \frac{RK}{K_1 - R}} = \sqrt{\frac{2 * 400}{1.8} \times \frac{12,000 \times 24,000}{12,000}} = 3,264 \text{ units / setup}$$

$$\text{Optimum cost} = 12,000 \times 4 + \sqrt{2C_1C_3R \cdot \frac{K - R}{K}} = 48,000 + \sqrt{2 \times 1.8 \times 400 \times 12,000 \times \frac{12,000}{24,000}} = 50,940 / \text{year}$$

$$\text{max. inventory } I_{mo} = \frac{K - R}{K} \cdot q_0 = \frac{24,000 - 12,000}{24,000} \times 3,264 = 1,632 \text{ units}$$

$$\text{manufacturing time}(t_1) = \frac{I_{mo}}{K - R} = \frac{1,632}{12,000} = 0.136 \text{ year}$$

$$\text{Time interval, } t_0 = \frac{q_0}{R} = \frac{3,264}{12,000} = 0.272 \text{ years}$$

Model 2(b) Demand Rate uniform, production Rate infinite, shortages allowed, time Interval fixed

$$\text{Optimum orders quantity is given by } I_{mo} = \frac{C_2}{C_1 + C_2} \cdot q = \frac{C_2}{C_1 + C_2} \cdot Rt$$

$$\text{The minimum average cost per unit time is given by } Co(I_m) = \frac{1}{2} \cdot \frac{C_1C_2}{C_1 + C_2} \cdot Rt$$

Example

A commodity is to be supplied at a constant rate of 25 units per day. A penalty cost is being charged at the rate of Rs. 10 per unit per day late for missing the scheduled delivery date. The cost of carrying the commodity in inventory is Rs 16 per unit per month. The production process is such that each month(30 days) a batch of items is started and are available for delivery and time after the end of the month. Find the optimal level of inventory at the beginning of each month.

Solution:

From the data of the problem in usual notations, we have

$$R = 25 \text{ units/day}$$

$$C_1 = \text{Rs } 16/30 = 0.53 \text{ per unit per day}$$

$$C_2 = \text{Rs } 10 \text{ per unit per day}$$

$$T = 30 \text{ days}$$

The optimal inventory level is given by = $\frac{10}{0.53 + 10} \times 25 \times 30 = 712 \text{ units}$

Model 2(c) Demand Rate uniform, production Rate finite, shortage allowed

This model has the same assumptions as in model 2(a) except that production rate is finite.

Example

Find the results of example 12.5 –2 if in addition to the data given in that problem the cost of shortages is also given as Rs. 5 per unit per year.

Solution

R = 9,000 units/year

C₃ = Rs. 100 / procurement,

C₁ = Rs. 2.40 / unit/year

C₂ = Rs. 5/ unit/year

$$i) q_o = \sqrt{\frac{C_1 + C_2}{C_2}} \cdot \sqrt{\frac{2C_3R}{C_1}} = \sqrt{\frac{2.40 + 5}{5}} \cdot \sqrt{\frac{2 \times 100 \times 9000}{2.4}} = 1053$$

$$ii) Co(Im, q) = 9000 \times 1 + \sqrt{\frac{C_2}{C_1 + C_2}} \sqrt{2C_1C_3R} = 9000 + \sqrt{\frac{5}{2.4 + 5}} \sqrt{2 \times 2.4 \times 100 \times 9000} = 10710 \text{ years}$$

$$iii) \text{ Number of orders/year, } N_0 = \frac{9000}{1053} = 8.55$$

$$iv) \text{ Time between orders, } t_o = \frac{1}{N_0} = \frac{1}{8.55} = 0.117 \text{ year}$$

Notes:

UNIT-VII

Game Theory

Many practical problems require decision making in a competitive situation. Where there are two or more opposite parties with conflicting interests and where the action of one depends upon the one taken by the opponent.

Competitive situations will be called as game if it has the following properties.

1. There are finite No of competitors called players.
2. Each player has to finite No of strategies available to him.
3. A play of the game takes place in each player employees his strategy.
4. Every game result in an out comes.

2 persons-zero-sum-game- when there are 2 competitors playing a game, is called 2 persons game.

1. Solve the following game by

- a. Min-Max Principle Method.
- b. Dominance- Method.

		Player B			
	B1	B2	B3	B4	
A1	1	7	3	4	
A2	5	6	4	5	
A3	7	2	0	3	

Solution:

1. Min-Max Principle Method:

Step:

1. Put tick (✓) to the minimum No of the each Row
2. Put + to Max of the each Column
3. Identify the element where both symbols meets

		Player B			
	B1	B2	B3	B4	
A1	1✓	7+	3	4	
A2	5	6	<u>4✓+</u>	5+	
A3	7+	2	0✓	3	

The optimal Strategy for player A is A2 and player B is B3 and the value of the game is 4

2. Dominance principle Method:

		Player B			
	B1	B2	B3	B4	
A1	1	7	3	4	
A2	5	6	4	5	

A3	7	2	0	3
----	---	---	---	---

Steps:

1. Row Comparison Inferiors.
2. Column comparison Superior.

1. The elements of the second column are superior to corresponding elements of 3rd column so delete II column.

The revised matrix is:

Sol: Player B

	B1	B3	B4
A1	1	3	4
A2	5	4	5
A3	7	0	3

2. The elements of I row are inferior to corresponding elements of II rows So Delete I row (A1)
The revised matrix is:

Sol: Player B

	B1	B3	B4
A2	5	4	5
A3	7	0	3

3. B1 is superior to B3 Delete B1.
The revised matrix is :

Sol: Player B

	B3	B4
A2	4	5
A3	0	3

4. A3 is inferior to A2 – Delete A3
The revised matrix is :

Sol: Player B

	B3	B4
A2	4	5

4. B4 is superior is to B3 Delete B4
The revised matrix is :

Sol: Player B

	B3
A2	4

The optimal strategy for player A is A2 and B is B3
The Value of the Game is 4

2. Solve the following game.

Player B

	I	II	III	IV
I	3	2	4	0
II	3	4	2	4
III	4	2	4	0
IV	0	4	0	8

Solution:

1. Min- Max Method:

Player B				
	I	II	III	IV
I	3	2	4+	0V
II	3	4+	2V	4
III	4+	2	4+	0V
IV	0V	4+	0V	8+

The Given Game does not posses the saddle point.

2. Dominance Method:

Player B				
	I	II	III	IV
I	3	2	4	0
II	3	4	2	4
III	4	2	4	0
IV	0	4	0	8

- 1. The Elements of A1 row are inferior to the corresponding elements of AIII row So Delete A1
The revised matrix is

Player B				
	I	II	III	IV
II	3	4	2	4
III	4	2	4	0
IV	0	4	0	8

B1 is superior to BIII So delete BI
The revised matrix is

Player B			
	II	III	IV
II	4	2	4
III	2	4	0
IV	4	0	8

3 2 4

The average of AIII & AIV rows i.e 2+4, 4+0, 0+8 are inferior to the corresponding elements of AII So delete row

The revised matrix is

Player B			
	II	III	IV
II	4	2	4

BII is superior to BIII – Delete BII (column)

The revised matrix is

Player B

	III	IV
II	2	4

BIV is superior to BIII So delete BIV

The revised matrix is

	III
II	2

The optimal strategy is player A=AII and B=BIII the value is 2

Games without saddle – point

Point to remember :

1. If the row & column are not equal make it equal by reducing one either row or column.
2. The values of P1,P2,& q1,q2 should not be –ve. If so, its value will be considered as Zero.
3. To determine the optimum strategy of both players by reducing the given matrix Ex: (2 x 3) (2 x 2)
4. if the player A is playing with less No of strategies than B then choose Max-Min principle.
5. if the player A is playing with more than No of strategies than B then choose Min-Max Principle.
6. The optimal point (Max-min point) is @ P intersected by B1 & B2.

Solve the Game whose pay-off matrix is

	B1	B2	B3	B4
A1	3	2	4	0
A2	3	4	2	4
A3	4	2	4	0
A4	0	4	0	8

Solution :

From the Above matrix:

A1 is inferior to A3 so delete A1

The revised matrix is

	B1	B2	B3	B4
A2	3	4	2	4
A3	4	2	4	0
A4	0	4	0	8

B1 is superior to B2 so delete B1

	B2	B3	B4
A2	4	2	4
A3	2	4	0
A4	4	0	8

B2 column is superior to the average B3 & B4 columns so delete B2

The revised matrix is:

	B3	B4
A2	2	4
A3	4	0
A4	0	8

A2 is inferior to the average of A3 and A4 rows so delete A2

The revised matrix is:

	B3	B4
A3	0	
A4	0	8

Further the game has no saddle point.

	B3	B4
A3	a11	a12
A4	a21	a22

Let the player A choose his strategies A3, A4 with probabilities P1 & P2. Such that **P1+P2=1**. Similarly player B chooses his strategies B3 & B4 with probabilities **q1 & q2**, such that **q1+q2=1**.

Formula

$$P1 = \frac{a22 - a21}{a11 + a22 - (a12 + a21)}$$

$$q1 = \frac{a22 - a12}{a11 + a22 - (a12 + a21)}$$

$$\text{Value of the Game} = \frac{a11 \times a22 - a12 \times a21}{a11 + a22 - (a12 + a21)}$$

$$P1 = \frac{a22 - a21}{a11 + a22 - (a12 + a21)}$$

$$= \frac{8 - 0}{4 + 8 - (0 + 0)}$$

$$= \frac{8}{12}$$

$$= 0.67$$

P1+P2=1 We know the value of P1=0.67 so when we substitute we get P2=1-0.67 P2=0.33

$$q1 = \frac{a22 - a12}{a11 + a22 - (a12 + a21)}$$

$$= \frac{8-0}{4+8-(0+0)}$$

$$= \frac{8}{12}$$

$$=0.67$$

$$q_2=1-q_1 \quad q_2=1-0.67 \quad q_2=0.33$$

$$\text{Value of the Game} = \frac{a_{11} \times a_{22} - a_{12} \times a_{21}}{a_{11} + a_{22} - (a_{12} + a_{21})}$$

$$= \frac{4 \times 8 - 0 \times 0}{4+8-(0+0)}$$

$$= \frac{32}{12}$$

$$= \frac{8}{3}$$

$$=2.67$$

Optimal strategy for Player A = (0, 0, p1, p2)
 = (0, 0, 0.67, 0.33)

Optimal Strategy for player B = (0, 0, q1, q2)
 = (0, 0, 0.67, 0.33)

Value = 2.67

2. Solve the game whose pay off matrix is:

	B1	B2	B3	B4	B5	B6
A1	1	3	-1	4	2	-5
A2	-3	5	6	1	2	0

Solution:

	B1	B2 /	B3 /	B4 /	B5 /	B6
A1	1	3 /	-1 /	4 /	2 /	-5
A2	-3	5 /	6 /	1 /	2 /	0

All Superior columns are deleted by comparison to corresponding elements revised matrix.

	B1	B6
--	----	----

A1	1	-5
A2	-3	0

$$P1 = \frac{a_{22}-a_{21}}{a_{11}+a_{22}-(a_{12}+a_{21})}$$

$$q1 = \frac{a_{22}-a_{12}}{a_{11}+a_{22}-(a_{12}+a_{21})}$$

$$\text{Value of the Game} = \frac{a_{11} \times a_{22} - a_{12} \times a_{21}}{a_{11}+a_{22}-(a_{12}+a_{21})}$$

$$P1 = \frac{a_{22}-a_{21}}{a_{11}+a_{22}-(a_{12}+a_{21})}$$

$$= \frac{0-(-3)}{(1+0)-(-5+-3)}$$

$$= \frac{3}{9}$$

$$0.33, \quad p_2 = 1-p_1 \quad p_2 = 1-0.33 = 0.67$$

$$q1 = \frac{a_{22}-a_{12}}{a_{11}+a_{22}-(a_{12}+a_{21})}$$

$$= \frac{0-(-5)}{9}$$

$$= \frac{5}{9}$$

$$= 0.56, \quad q_2 = 1-q_1 \quad q_2 = 1-0.56 = 0.44$$

Value of the Game

$$\text{Value of the Game} = \frac{a_{11} \times a_{22} - a_{12} \times a_{21}}{a_{11}+a_{22}-(a_{12}+a_{21})}$$

$$= \frac{(1 \times 0) - (-5 \times -3)}{(1+0)-(-5+-3)}$$

$$= \frac{0-15}{1-(-8)}$$

$$= 1.67$$

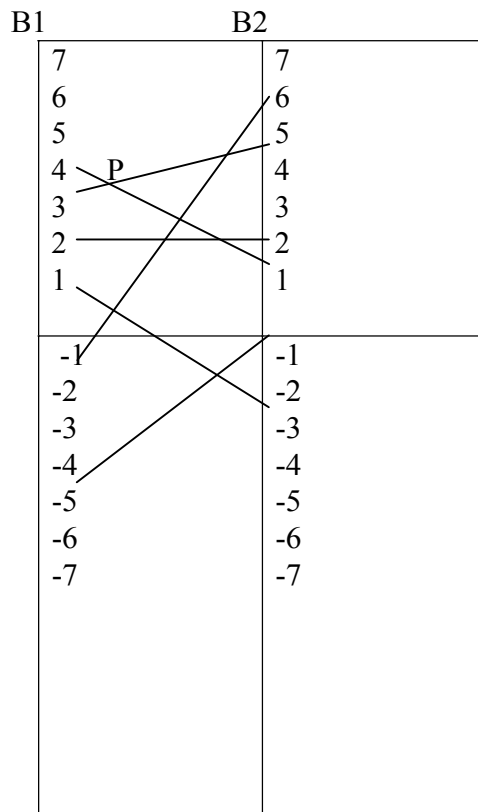
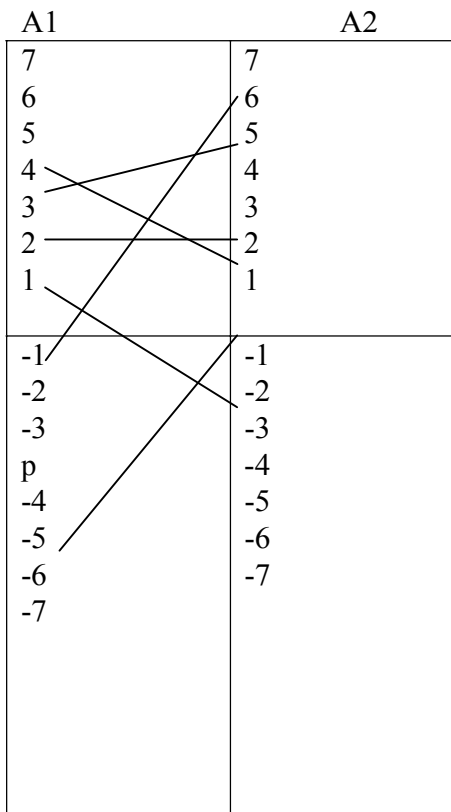

UNIT - VIII

Integer Programming

The replacement problem arises because of two factors:

1. First, the existing unit or units may have outlived their effective lives and it may not be economical to allow them to continue in the organization.
2. Second, the existing unit or units may have been destroyed through accident or otherwise.

In the case of items whose efficiency go on decreasing according to their, it requires to spend more money on account of increased operating cost, increased repair cost, increased scrap, etc. In such cases the replacement of an old item with new one is the only alternative to prevent such increased expenses. Thus, it becomes necessary to determine an age at which replacement is more economical rather than to continue at increased cost. The problems of replacements are encountered in the case of both men and machines. By applying probability it is possible to estimate the chance of death at various ages.

Types of replacement problems:

1. Replacement of capital equipment that becomes worse with time, e.g. machines tools, buses in a transport organization, planes, etc
2. Group replacement of items which fail completely, e.g. light bulbs, radio tubes, etc.
3. Problems of mortality and staffing.
4. Miscellaneous problems.

1. The cost of machine is Rs 6100 and its scrap value is only Rs 100. The maintenance costs are found from experience to be:

Year	1	2	3	4	5	6	7	8
Mtn-Cost	100	250	400	600	900	1250	1600	2000

When should the machine be replace?

Solution:

First, find an average cost per year during the life of the machine as follows.

These computations may be summarized in the following

Replace at the end of the year (n)	Maintenance cost an	Total maintenance cost	Difference b/w Price and Resale price	Total cost	Average cost
(n)	R _n	∑	(c-s)	[p(n)]	P(n)/n
1	100	100	6000	6100	6100
2	250	350	6000	6350	3175
3	400	750	6000	6750	2250
4	600	1350	6000	7350	1837.50
5	900	2250	6000	8250	1650
6	1250	3500	6000	9500	1583.33
7	1600	4100	6000	11100	1585.71

--	--	--	--	--	--

Here it is observed that the maintenance cost in the 7th year becomes greater than the average cost for 6 years. Hence the machine should be replaced at the end of 6th year.

2. Machine owner finds from his past records that the costs per year of maintaining a machine whose purchase price is Rs 6000 are as given below:

Year	1	2	3	4	5	6	7	8
Mtn Cost	1000	1200	1400	1800	2300	2800	3400	4000
Resale price	3000	1500	750	375	200	200	200	200

At what age is a replacement due?

Solution: As in example 1, the machine should be replaced at the end of the fifth year, because the maintenance cost in the 6th year becomes greater than the average cost for 5 years.

Here the average cost per year during the life of the machine.

Replace at the end of year (n)	Maintenance cost	Total maintenance cost	Difference b/w price and resale price	Total cost	Average cost
(n)	R _n	∑R _n	(c-s _n)	P(n)	P(n)/n
1	1000	1000	3000	4000	4000
2	1200	2200	4500	6700	3350
3	1400	3600	5250	8850	2950
4	1800	5400	5625	11025	2756
5	2300	7700	5800	13500	2700
6	2800	10500	5800	16300	2717

1. An Engineering company is offered a material handling equipment A. A is priced at Rs.60,000. including cost of installation; and the cost for operation and maintenance are estimated to be Rs. 10,000 for each of the first five years, increasing every year by Rs.3,000 per year in the sixth and subsequent years. The company expects a return of 10% on all its investment. What is the optimal replacement period?

Year n	Running cost R _n	Cumulative running cost	Depreciation cost	TC	ATC
(1)	(2)	(3)	(4)	(3+4)	(5)/(1)
1	1,000	1,000	45000	46000	46000
2	11,000	12000	45000	57000	28500
3	21,000	33000	45000	78000	26000
4	31,000	64000	45000	109000	27250
5	41,000	1051000	45000	150000	30000
6	51,000	156000	45000	2,01000	33500

Year n	Running cost R _n	Cumulative running	Depreciation cost	TC	ATC
--------	-----------------------------	--------------------	-------------------	----	-----

		cost			
(1)	(2)	(3)	(4)	(3+4)	(5)/(1)
1	2,000	2,000	50000	52000	52000
2	6,000	8000	50000	58000	29000
3	10,000	18000	50000	68000	22667
4	14,000	32000	50000	82000	20500
5	18,000	50000	50000	100000	20000
6	22,000	72000	50000	1,22,000	20333

A should be replaced by

2. A computer contains 10,000 resistors. When any resistor fails, it is replaced. The cost of replacing a resistor individually is Re.1 only. If all the resistors are replaced at the same time, the cost per resistor would be reduced to 35 paise. The percentage of surviving resistors say $S(t)$ at the end of month t and $P(t)$ the probability of failure during the month t are:

T	0	1	2	3	4	5	6
S(t)	100	97	90	70	30	15	0
P(t)	-	0.03	0.07	0.20	0.40	0.15	0.15

What is the optimal replacement plan?

$N_0=10,000$

$N_1=300$

$N_2=709$

$N_3=2042$

$N_4=4171$

$N_5=2030$

$N_6=2590$

Expected life = 4.02 months

Avg Failures = 2488 resistors

End of month	TC	ATC
1	3,800	380,00
2	4,509	2254.50
3	6,551	2183.66
4	10,722	2680.5
5	12,752	2550.40
6	15,442	2557.00

3. Machine A costs Rs.45,000 and the operating costs are estimated at Rs.1000 for the first year increasing by Rs.10,000 per year in the second and subsequent years. Machine B costs Rs.50,000 and operating costs are Rs.2,000 for the first year, increasing by Rs.4,000 in the second and subsequent years. If we now have a machine of type A, should we replace it with B? If so when? Assume that both machines have no resale value and future costs are not discounted.

Year n	Running	Discounted	Rn Dn-	Cummulative	C+cummulative	C	W(n)
--------	---------	------------	--------	-------------	---------------	---	------

	cost Rn	factor Dn-1	1				
(1)	(2)	(3)	(2)*(3)	(5)	60,000+(5)	(7)	(6)/(7)
1	10,000	.909	9,090	9,090	69,090	.909	36,192
2	10,000	.826	8,260	17,350	77,350	1.735	28,282
3	10,000	.757	7,510	24,860	84,860	2.486	24,343
4	10,000	.683	6,830	31,690	91,690	4.169	21,993
5	10,000	.621	6,210	37,900	97,900	4.790	20,438
6	13,000	.564	7,332	45,232	1,05,232	5.354	19,655
7	16,000	.513	8,208	53,440	1,13,440	5.867	19,335
8	<u>19,000</u>	<u>.466</u>	<u>8,854</u>	<u>62,294</u>	<u>1,22,294</u>	<u>6.333</u>	<u>19,311</u>
9	22,000	.424	9,328	71,622	1,31,622	6.757	19,479
10	25,000	.385	9,650	81,247	1,41,247	7.142	19,777